

Furniture of America[®]

Assembly Instructions

WI3990SK-PC-2PK

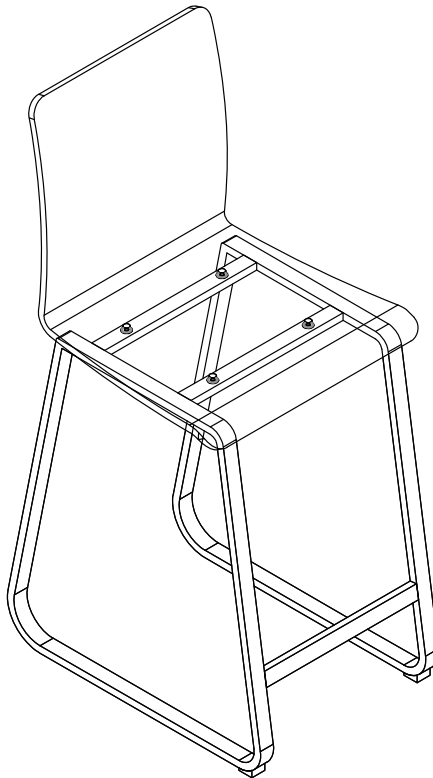

ASSEMBLY RATING

The Assembly Rating is a 5-point system that shows the degree of effort needed in assembling a specific product (with 1 being easy and 5 being difficult). For some products, two persons are recommended.

EASY



DIFFICULT

Tools Required For Assembly:

Allen Wrench

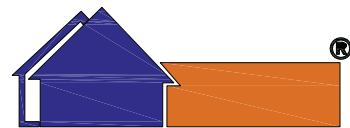
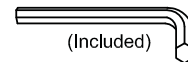

Furniture of America[®]

ASSEMBLY & CARE ADVICE

FOR YOUR FURNITURE TO LAST, CORRECT ASSEMBLY AND PROPER MAINTENANCE ARE NECESSARY. PLEASE FOLLOW THE INFORMATION PROVIDED BELOW TO FULLY ENJOY YOUR FURNITURE.

BASIC ASSEMBLY TECHNIQUES

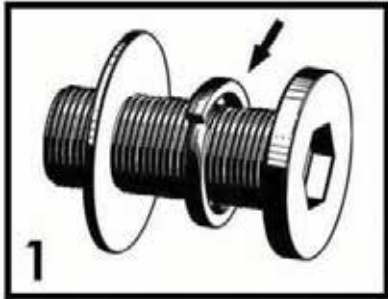

1 When lock or spring washer is used in an assembly, please make sure the lock or spring washer is placed between the larger flat washer and the head of the screw or bolt.



2 Position each part correctly and insert screws or bolts into their respective holes by hand tighten or using the proper hand tool. Only tighten when step is completed or when instructed to do so.



3 Use cardboard or carpet area when assembling furniture to prevent scratches. Make sure the furniture rests on a flat and level surface with each leg evenly touching the floor.

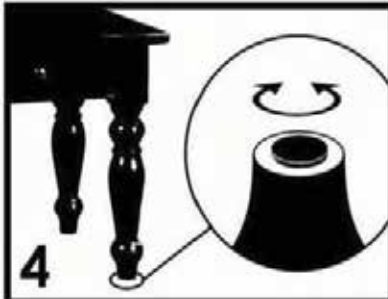

4 Some furniture comes with height adjustment knobs underneath each leg. To lower or to raise each leg, you need to turn clockwise or counterclockwise, respectively.



5 Make sure all parts are properly aligned, then use the appropriate hand tool to completely tighten the bolts or screws. Do not use power tools and do not overtighten.

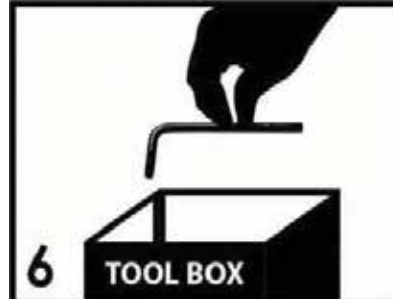

6 Save the instructions and store the Allen wrench or any supplied tool for later maintenance. After two weeks, check and tighten any loose hardware and repeat again every six months thereafter.

IT IS THE USER'S RESPONSIBILITY TO MAINTAIN THE FURNITURE. THE HARDWARE MAY LOOSEN OVER TIME AND MAY CAUSE THE FURNITURE TO BE WOBBLY AND UNABLE TO SUPPORT ITS INTENDED WEIGHT CAPACITY. THIS MAY LEAD TO COLLAPSE AND MAY CAUSE SERIOUS INJURY.

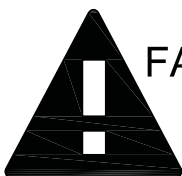



FAILURE TO FOLLOW THE GUIDELINES ABOVE MAY RESULT IN INJURY AND/OR PROPERTY DAMAGE.



Before you begin, please read Page 2 of "Assembly and Care Advice".

And remember, do not tighten until each step is completed or instructed.

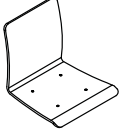

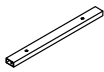
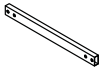



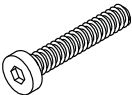

Parts List

-  #1 x 1pc x2
Chair Seat
-  #2 x 1pc x2
Left Frame
-  #3 x 1pc x2
Right Frame
-  #4 x 2pcs x2
Top Crossbar
-  #5 x 1pc x2
Bottom Crossbar

Hardware List

-  #A x 12pcs x2
Bolt $\text{\O}1/4"$ x $1/2"$
-  #B x 4pcs x2
Bolt $\text{\O}1/4"$ x $1"$

Hardware List

-  #C x 18pcs x2
Flat Washer $\text{\O}1/4"$
-  #D x 16pcs x2
Lock Washer $\text{\O}1/4"$
-  #E x 4pcs x2
Plastic Washer $\text{\O}1/4"$
-  #F x 4pcs x2
Nut $\text{\O}1/4"$
-  #G x 2pcs x2
Floor Leveler
-  #H x 2pcs x2
Flat Bolt $\text{\O}1/4"$ x $1/2"$
-  #I x 2pcs x2
Cap
-  #J x 1pc x2
Allen Wench 4mm



- #A x 12pcs
- #C x 14pcs
- #D x 12pcs
- #G x 2pcs
- #H x 2pcs
- #I x 2pcs

1. Prepare 12 bolt assemblies by first inserting a lock washer (#D) onto the bolt (#A) then a flat washer (#C) onto that same bolt (#A).

3. Apply a flat washer(#C) onto the bolt (#H). Then align a cap (#I) to the holes along the bottom front ends of the frames and insert a bolt assembly into each. Secure using the Allen wrench (#J).

2. Insert 2 top crossbars (#4) and 1 bottom crossbar (#5) onto the small bars along the left and right frames (#2,3). Then insert 2 bolt assemblies into each end and secure using the Allen wrench (#J).

4. Insert a floor leveler (#G) into the holes along the bottom of the left and right frames (#2,3).

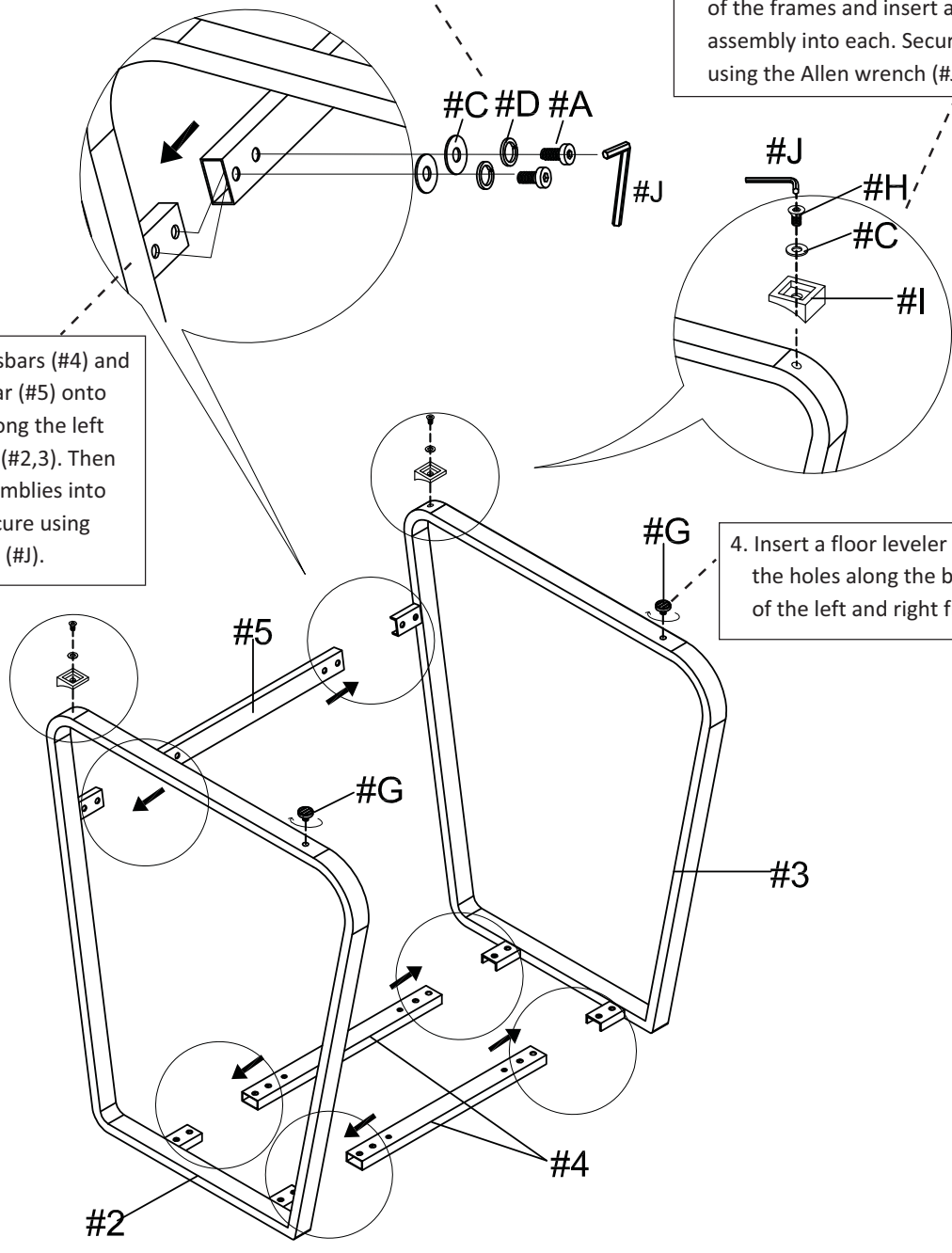



1. Turn the frames upright.

2. Prepare 4 bolt assemblies by first inserting a lock washer (#D) onto the bolt (#B) then a flat washer (#C) onto that same bolt (#B).

#B x 4pcs
#C x 4pcs
#D x 4pcs
#E x 4pcs
#F x 4pcs

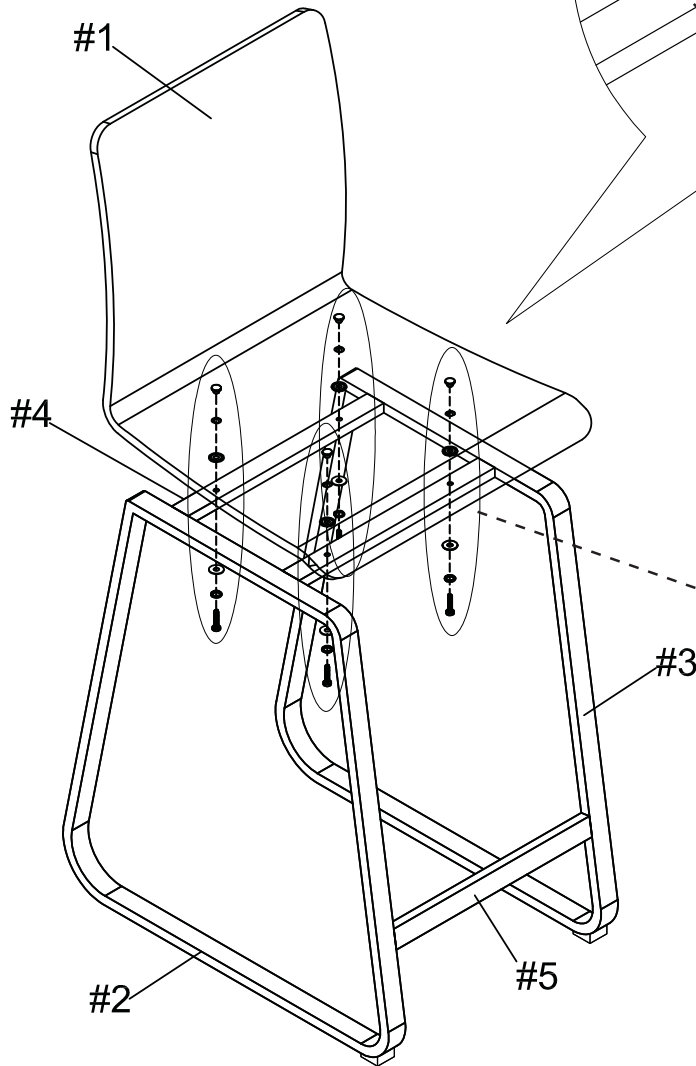
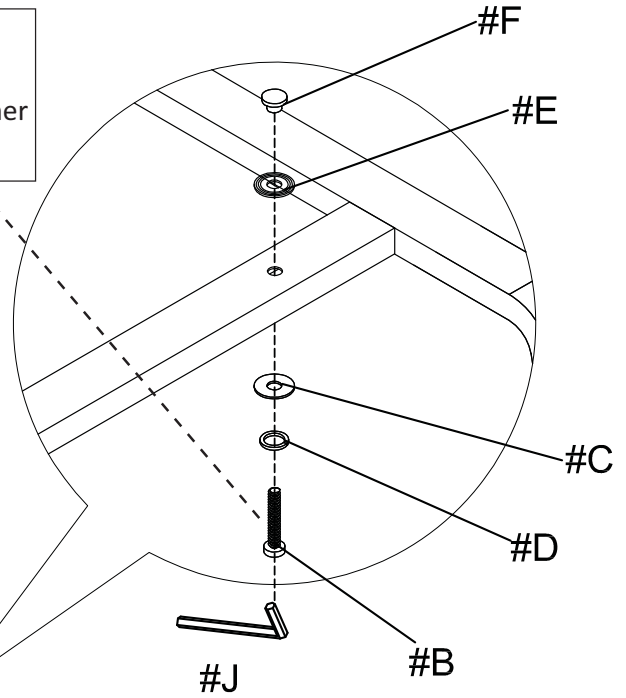

3. Carefully place the chair seat (#1) onto the frames and align the holes. From below insert the 4 bolt assemblies and secure using the Allen wrench (#J). Then from above apply a plastic washer (#E) and a nut (#F).