

Product Description / Description du Produit / Descripción Del Producto

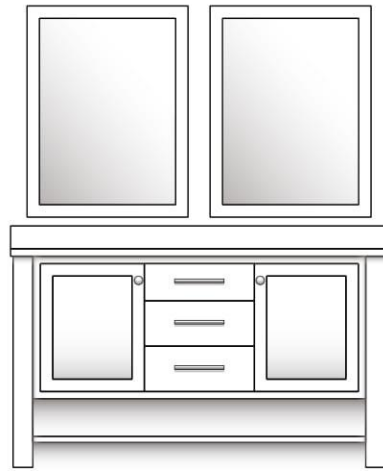

Product Measurements / Dimensions Du Produit / Medidas Del Producto

- Width / Largeur / Ancho: 60in (1520mm)
- Depth / Profondeur / Profundidad: 22in (560mm)
- Height / Hauteur / Alto: 34.6in (880mm)

Before You Begin / Avant De Commencer / Antes De Comenzar

1. Prior to installation, unpack your new product and inspect it. Keep the product in its original package until you are ready to install it.
 2. The wall must be square, plumb and level.
 3. Shut the water supply off when replacing an existing fixture. Preparation of the floors and walls, including all additional wall supports, may be required.
 4. Observe all local plumbing and building codes.
 5. It is recommended that this installation be done with a minimum of two people. Do not install this fixture alone.
 6. strongly recommends using a professional and certified plumber to install this fixture.
1. Avant de procéder à l'installation, déballez votre nouveau produit et vérifiez son état. Conservez le produit dans son emballage d'origine jusqu'à ce que vous soyez prêt à l'installer.
 2. Le mur doit être droit, d'aplomb et de niveau.
 3. Coupez l'alimentation en eau avant de retirer le lavabo déjà en place. La préparation des planchers et des murs, notamment l'installation de supports muraux supplémentaires, peut s'avérer nécessaire.
 4. Conformez-vous à tous les codes de plomberie et à tous les codes de construction locaux.
 5. Nous recommandons un minimum de deux personnes pour l'installation de ce produit. Ne tentez pas d'installer ce produit seul.
 6. recommande fortement l'utilisation d'un plombier professionnel et certifié pour installer cet appareil.
1. Antes de la instalación, saque su nuevo producto de la caja e inspeccionelo. Mantenga el producto dentro de su empaque original hasta que tenga todo listo para instalarlo.
 2. La pared debe estar a escuadra, a plomo y a nivel.
 3. Cuando reemplace una instalación existente, cierre la llave de paso del agua. Puede ser necesario preparar los pisos y las paredes, incluso pueden ser necesarios soportes de pared adicionales.
 4. Respete todos los códigos locales de plomería y construcción.
 5. Se recomienda realizar la instalación entre dos personas como mínimo. No realice la instalación usted solo.
 6. recomienda el uso de un plomero profesional y certificado para instalar este aparato.

Recommended Tools / Outils Recommandés / Herramientas Recomendadas

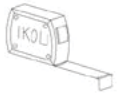

Tape Measure /
Ruban à mesurer /
Cinta Métrica



Pencil /
Crayon /
Lápiz



Ruler /
Règle /
Regla



Pipe Wrench /
Clé à tuyau /
Llave inglesa



Adjustable Wrench /
Clé à molette /
Llave ajustable



Level /
Niveau /
Nivel



Channel Locks /
Pince Multiprise /
Pinzas de extensión



Goggles /
Lunettes /
Gafas



Hacksaw /
Scie à métaux /
Sierra de mano



Putty Knife /
Couteau à mastic /
Espátula



Plumber's Putty/Caulking /
Mastic de plomberie/calfeutrage /
Masilla para plomería/sellador



Pipe Cutter /
Coupe-tuyau /
Cortador de tubería



Flathead Screwdriver /
Tournevis plat /
Destornillador plano



Phillips Screwdriver /
Tournevis cruciforme /
Destornillador Phillips



Drill /
Perceuse /
Taladro



Pipe Clamp /
Collier de serrage pour tuyau /
Abrazadera de tubería



Square /
Équerre /
Escuadra



Jig Saw /
Scie à découper /
Sierra de sable

Parts / Pièces / Piezas

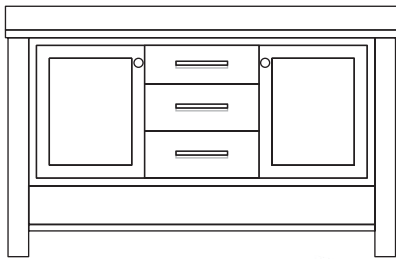

A

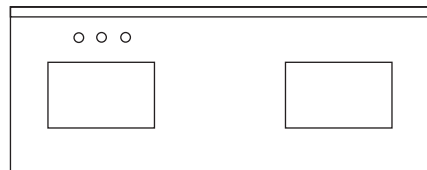

B

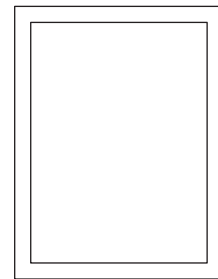

C

Item	Description	Qty.
A	Vanity / Vanité / Vanidad	1
B	Countertop / Comptoir / Mostrador	1
C	Mirror / Miroir / Espejo	2

Roughing-In Dimensions / Mesures Relatives aux Points de Raccordement / Medidas Aproximadas

UNITS IN INCHES (") / UNITÉS EN POUÇES (") / UNIDADES EN PULGADAS (")

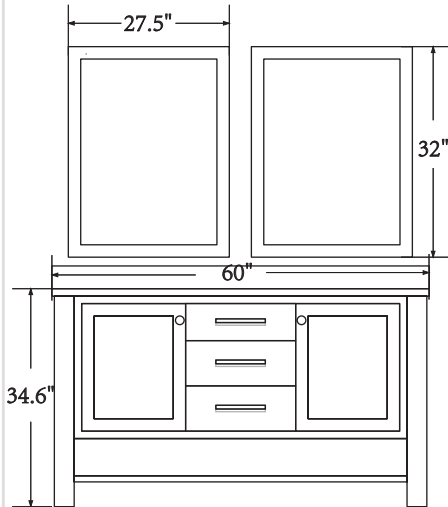

1 Front / Avant / Frente

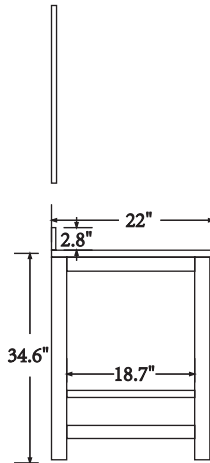

2 Left / Gauche / Izquierda

Supply lines area
D'approvisionnement
des lignes secteur
Área de la lines
suministro

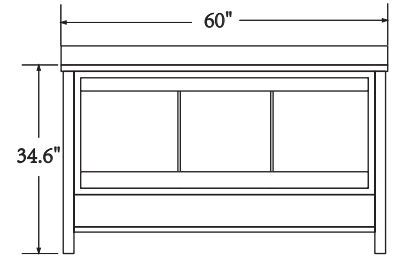

3 Rear / Arrière / Espalda

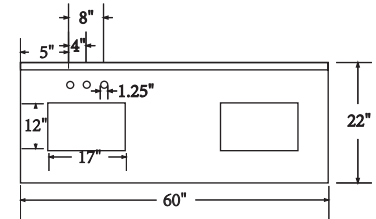

4 Top / Haut / Encima

Note: Height may vary depending on material of top
Note: La hauteur peut varier en fonction du matériau du top
Nota: La altura puede variar dependiendo del material de los mejores



USA & CANADA

Recommended Accessories / Accessoires Recommandés / Accesorios Recomendados

- Classic Faucet - Reckline Faucet - Varese Faucet
- Curviz Faucet - Robo Faucet - Bamboo Faucet

STEP #1

- With assistance, place vanity (A) in desired location and level.
- It is recommended to locate at least one wall stud within area where vanity (A) is to be installed. Pre-drill holes through wall studs. Using wood screws, fasten vanity to wall stud.
- NOTE: Wood screws are not provided! Refer to Figure #1.

Installation Instructions / Instructions D'Installation / Instrucciones De Instalación

ÉTAPE 1

- Avec l'aide d'une autre personne, placez le meuble-lavabo (A) à l'emplacement désiré et le niveau.
- Il est conseillé de repérer au moins un poteau mural près de l'endroit où sera installé le meuble-lavabo (A). Percez les avant-trous dans la traverse en bois horizontale supérieure et dans le poteau mural. Utilisez des vis à bois pour fixer le meuble-lavabo dans la traverse en bois horizontale supérieure.
- REMARQUE: Les vis à bois ne sont pas fournies! Reportez-vous à la Figure 1.

PASO N° 1

- Con la ayuda de otra persona, coloque el tocador (A) en la posición deseada y el nivel.
- Se recomienda ubicar por lo menos un montante dentro del área donde se va a instalar el tocador (A). Haga agujeros en el travesaño superior horizontal de madera y en el montante de pared. Usando tornillos para madera, sujete el tocador al montante de pared a través del travesaño superior horizontal de madera.
- NOTA: Los Tornillos para madera no están incluidos! Vea la Figura 1.

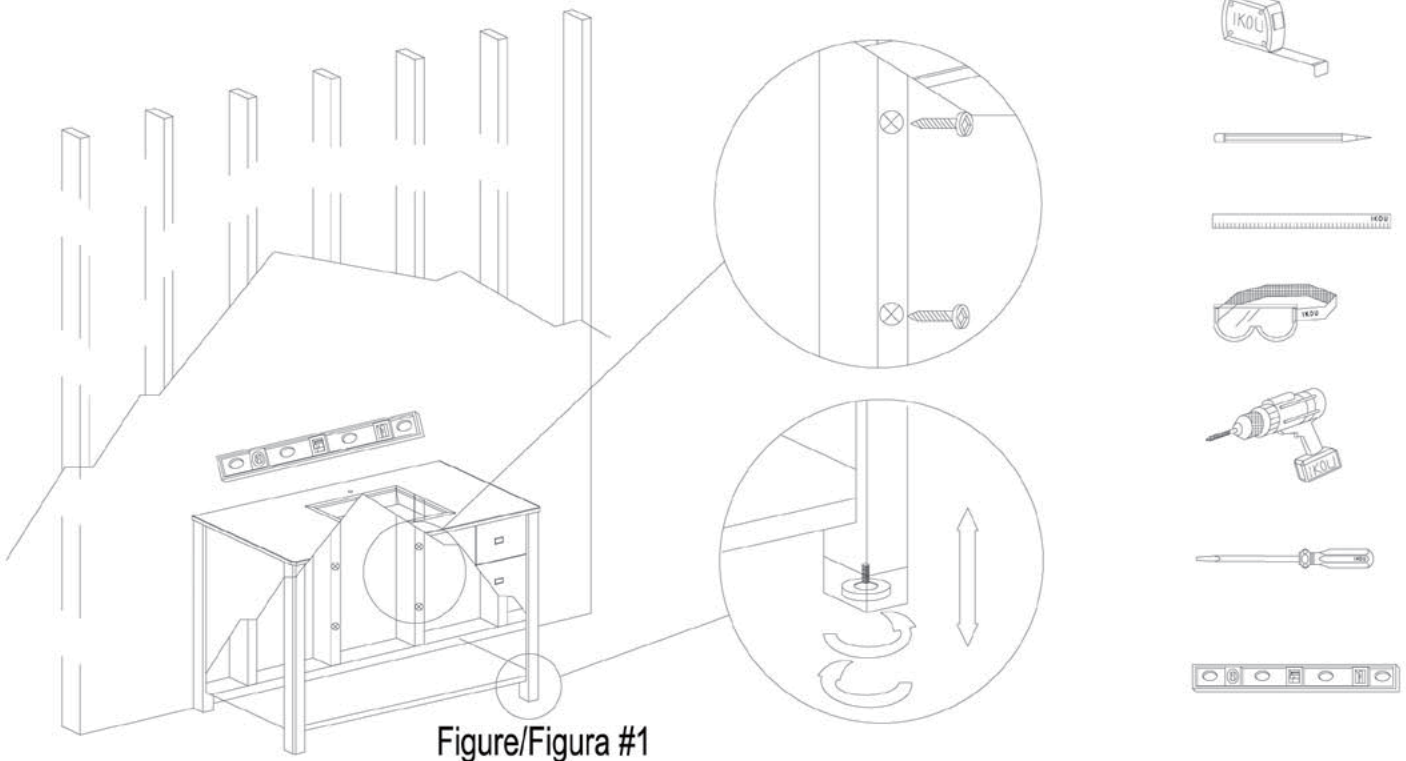

Installation Instructions / Instructions D'Installation / Instrucciones De Instalación

STEP #2

- Install drain and faucet assembly according to manufacturer's installation instructions.
- Refer to Figure #2A and #2B

ÉTAPE #2

- Installez l'assemblage du drain et le robinet conformément aux instructions d'installation du fabricant.
- Reportez-vous à la Figure 2A et 2B.

PASO N° 2

- Instale el conjunto de desagüe y el grifo según las instrucciones de instalación del fabricante.
- Vea la Figura 2A y 2B.

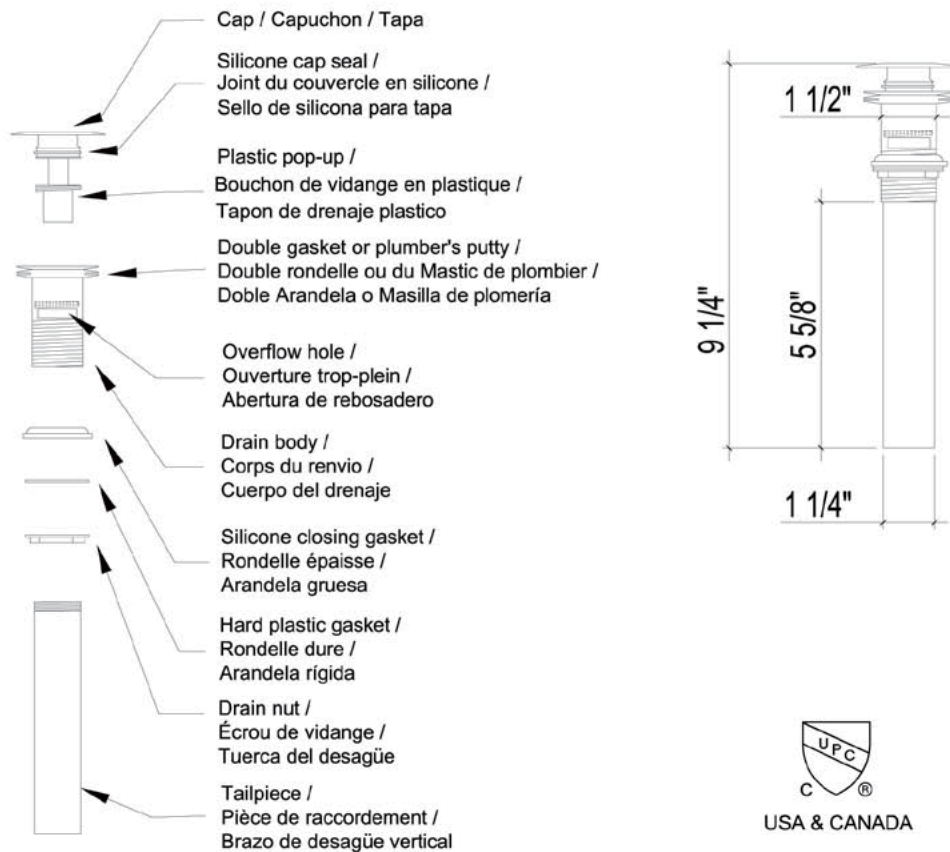

Figure/Figura #2A

Installation Instructions / Instructions D'Installation / Instrucciones De Instalación

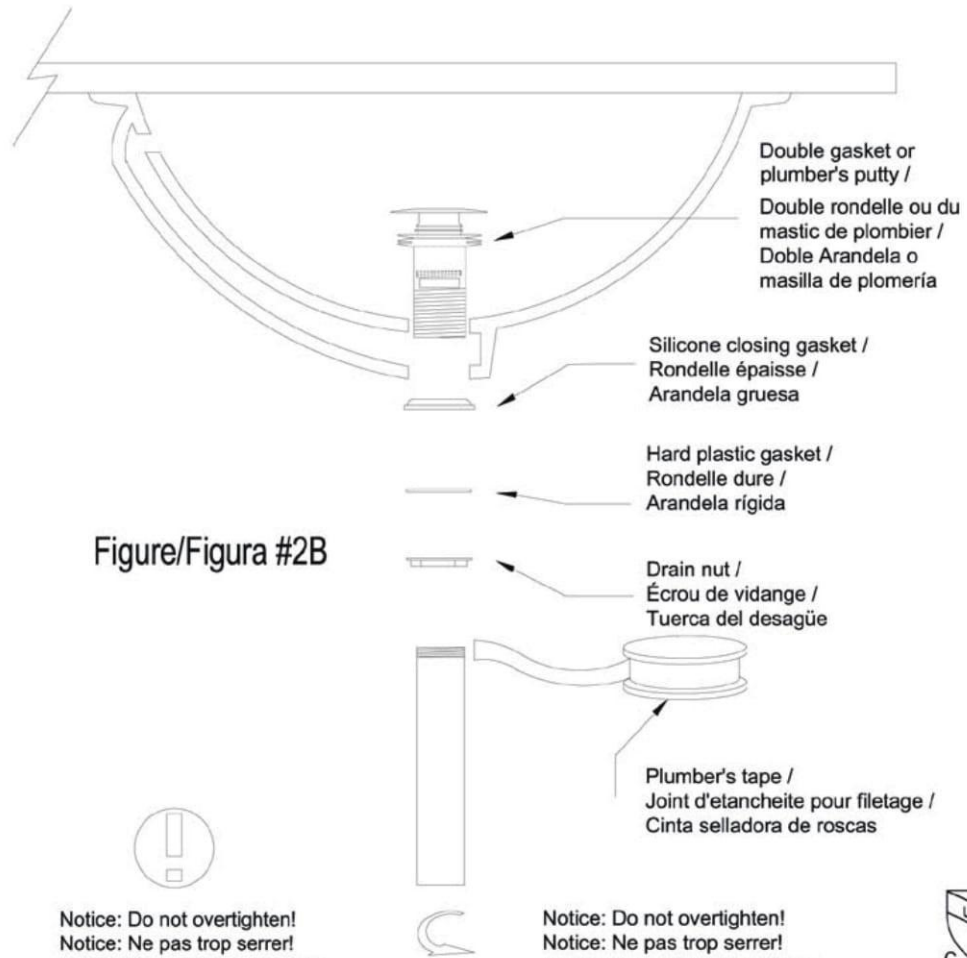
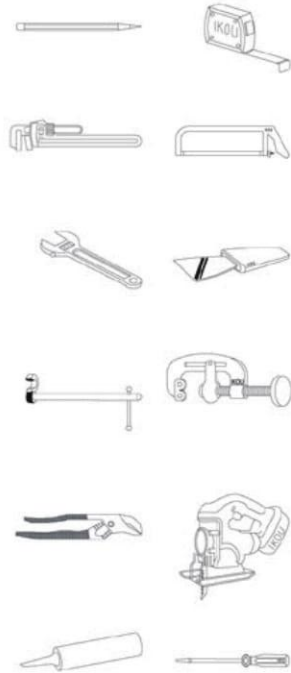

Notice: Do not overtighten!
Notice: Ne pas trop serrer!
Aviso: ¡No apriete demasiado

Notice: Do not overtighten!
Notice: Ne pas trop serrer!
Aviso: ¡No apriete demasiado



Care and Cleaning

- DO NOT OVERTIGHTEN DRAIN OR SUPPLY LINES. This may result in damage to your product, as well as cause water leakage.
- DO NOT clean the product with detergents, acids, abrasives, harsh cleaners or a cloth with a coarse surface. This is good advice for any plumbing fixture regardless of material.
- DO NOT leave any cleaning agents other than water on your product.
- DO NOT allow your product to unnecessarily encounter other solid objects.
- DO clean your product. Wipe with a damp cloth and dry with a soft cloth. If necessary, a general mild soap and water solution can be used.
- DO clean underside of your product with mild soap and water ONLY.
- DO wipe your product with clean, dry, soft cloth after each use, as it will limit water spots, especially in hard water areas
- DO clean your mirror. Wipe with a glass cleaner and a clean soft cloth. Use a mild furniture polish to clean wood frame.
- recommends proper sealing of ALL natural stone products PRIOR TO INSTALLATION.

Entretien et Nettoyage

- **NE PAS TROP SERRER LES LIGNES DE VIDANGE ET ALIMENTATION.** Cela peut entraîner des dommages à votre produit , ainsi que les fuites d'eau cause.
- **N'UTILISEZ PAS** de produits contenant des détergents, de l'acide, des abrasifs ou des nettoyeurs forts, ni de chiffon à surface rugueuse. Ce conseil s'applique à tout produit de plomberie, peu importe le type de matériau.
- **NE LAISSEZ AUCUN** produit nettoyant autre que de l'eau sur votre produit
- **NE LAISSEZ PAS** d'objets solides heurter votre produit inutilement.
- **NETTOYEZ** votre produit à l'aide d'un chiffon humide et séchez-le avec un chiffon doux. Au besoin, utilisez une solution d'eau et de savon doux d'application générale.
- **NETTOYEZ** le dessous de votre produit avec de l'eau et du savon doux **SEULEMENT.**
- **ESSUYEZ** votre produit à l'aide d'un chiffon doux, sec et propre après chaque utilisation pour limiter la formation de taches causées par l'eau, plus particulièrement dans les régions où l'eau est calcaire.
- **NETTOYEZ** votre miroir Essuyer avec un nettoyant pour vitres et un chiffon doux et propre. Utilisez un poli furniture doux pour nettoyer le bois.
- recommande de sceller adéquatement **TOUS** les produits en pierre naturelle **AVANT DE PROCÉDER À L'INSTALLATION.**

Cuidado Y Limpieza

- **NO APRIETE DE LAS LÍNEAS DE DRENAJE O SUMINISTRO.** Esto puede provocar daños en el producto , así como fugas de agua causa.
- **NO** limpie el producto con detergentes, ácidos, abrasivos, limpiadores fuertes ni paños cuyas superficies no sean lisas, como los paños.
- Este consejo es útil para todos los accesorios de plomería, sin importar cuál sea al material.
- **NO** deje agentes de limpieza, salvo agua, sobre su producto
- **NO** deje que su producto entre en contacto innecesario con otros objetos sólidos.
- **LIMPIE** su producto . Limpie con un paño húmedo y seque con un paño suave. Si es necesario, puede usar una solución de jabón suave y agua.
- **LIMPIE** la parte inferior de su producto **SOLAMENTE** con jabón suave y agua.
- **SEQUE** su producto con un paño limpio, suave y seco luego de cada uso para evitar las machas producidas por el agua, especialmente en áreas con agua dura.
- **LIMPIE** su espejo . Limpie con un limpiador de vidrios y un paño suave y limpio. Use un limpiador suave para limpiar furniture marco de madera.
- **PTN Systems** recomienda sellar correctamente **TODOS** los productos de piedra natural **ANTES DE LA INSTALACIÓN.**

Installation Instructions / Instructions D'Installation / Instrucciones De Instalación

STEP #3

- Apply silicone to bottom edge of the countertop (B).
- Place the countertop (B) carefully in position.
- Align countertop (B) to vanity (A) and wipe off excess silicone if needed.
- Refer to Figure #3

 Optional: if suction cups [4x] are present, install them in the corresponding holes on the vanity top. See Figure (1).

ÉTAPE #3

- Appliquez de la silicone autour de la partie inférieure du comptoir (B).
- Positionnez délicatement le comptoir (B).
- Alignez le lavabo en comptoir (B) avec le meuble-lavabo (A) et essuyez l'excédent de silicone au plateau.
- Reportez-vous à la Figure 3.

 Facultatif: si ventouses [4x] sont présents, les installer dans les trous correspondants sur le dessus de vanité. Voir figure (1).

PASO N° 3

- Aplique silicona al borde inferior del encimera de mostrador (B).
- Coloque el encimera de mostrador (B) cuidadosamente en su lugar.
- Alinee el encimera de mostrador (B) con el tocador (A) y quite el excedente de silicona si fuera necesario.
- Vea la Figura 3.

 Opcional: si las copa de succión [4x] están presentes, instáuelos en los agujeros correspondientes en la tapa de la vanidad. Véase la figura (1).

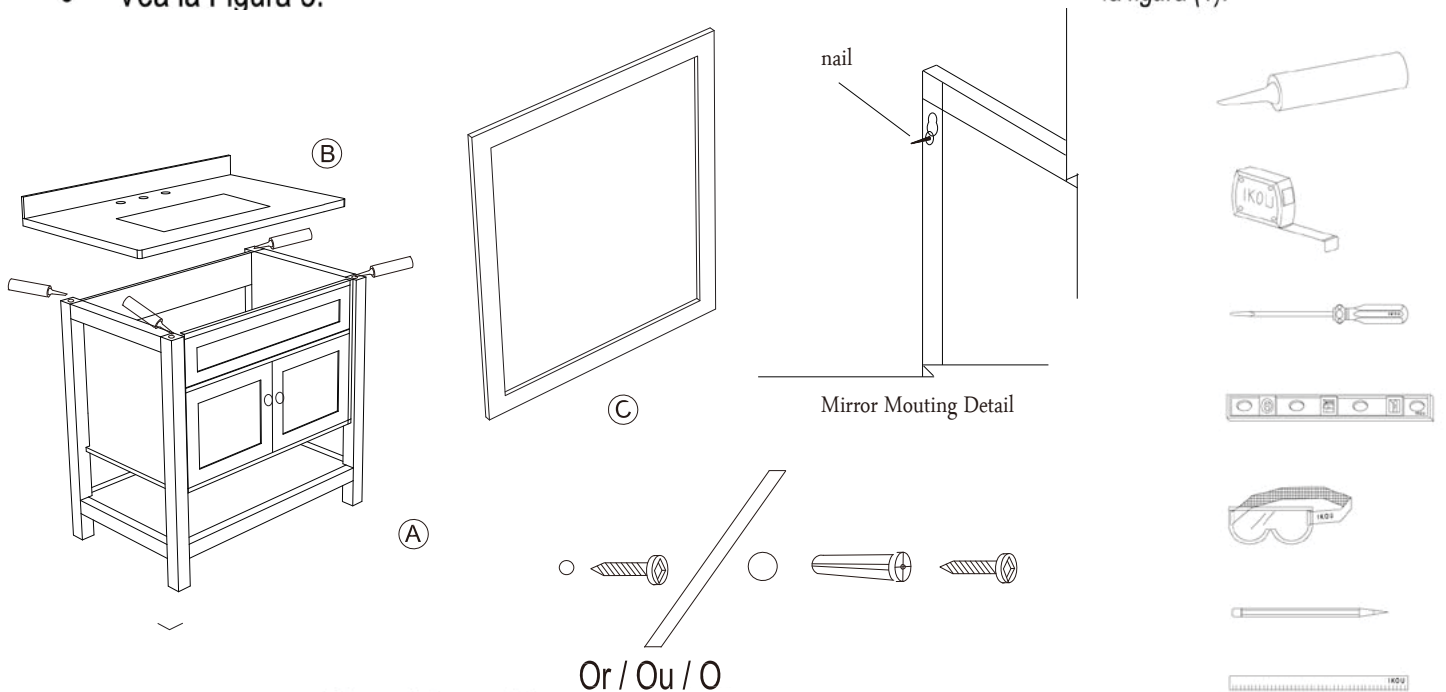

Figure/Figura #3

Limited 2-year Warranty

We warranty all our products to the original end consumer to be free of true defect(s) in material and workmanship for two (2) years from the date of initial purchase, subject to the following restrictions:

- We are notified promptly in writing, via fax, mail or email, by the Retailer/Wholesale Purchase upon discovery of any alleged defect(s) in the product(s), including a detailed description of the alleged defect(s).
- Proof of purchase (original sales receipt) from the original end consumer must be made available to us for all warranty claims.
- Authorized our personnel has inspected the product(s) and determined the product(s) to have true manufacturing defect(s)

The Limited Two-Year Warranty is non-transferable and applies only to the original end consumer and to the original installation of the product(s). This Limited Two-Year Warranty is void if the product(s) has been moved from its initial installation site or if the ownership of the product(s) has changed.

Our products are produced from natural raw materials and there is a slight color variance.

This is NOT a manufacturing defect and will not be covered under the Limited Two-Year Warranty.

This Limited Two-Year Warranty does not apply to local building code compliance. Since local building codes vary considerably, the original end consumer of the product(s) should check with a local building or plumbing contractor to ensure local code compliance before installation. This Limited Two-Year Warranty does not cover any mechanical pieces of any product(s). These mechanical pieces will be covered under a Limited One Year Warranty, based on the same criteria as this Limited Two-Year Warranty, from the date of initial purchase. Upon satisfaction of each of the foregoing conditions and requirements, we shall, at our option, either repair or replace such defective product(s). We shall return any product(s) repaired or replaced under this Limited Two-Year Warranty to the original end consumer transportation prepaid.

All discontinued product(s), at the time of claim, will either be repaired or replaced with a comparable item. Our option to repair or replace the product(s) under this Limited Two-Year Warranty does not cover any cost of labor, installation, usage and delay time, or other costs of removal or installation whatsoever.

IN NO EVENT WILL WE BE LIABLE FOR THE COST OF REPAIR OR REPLACEMENT OF ANY INSTALLATION MATERIALS, INCLUDING BUT NOT LIMITED TO TILES, MARBLE, ETC... This Limited Two-Year Warranty does not cover any liability for consequential or incidental damages, all of which are hereby expressly disclaimed, or the extension beyond the duration of this Limited Two-Year Warranty.

THE WARRANTIES HEREIN (A) ARE EXCLUSIVE AND STATED IN LIEU OF ALL OTHER WARRANTIES, WHETHER EXPRESS, STATUTORY, OR IMPLIED, INCLUDING BUT NOT LIMITED TO THE WARRANTIES OF MERCHANTABILITY AND FITNESS FOR AN INTENDED PURPOSE, ALL OF WHICH ARE HEREBY EXPRESSLY DISCLAIMED, (B) NEITHER ASSUME NOR AUTHORIZE PURCHASER NOR ANY OTHER PARTY TO ASSUME FOR US ANY OTHER LIABILITIES IN CONNECTION WITH THE MANUFACTURE OR SALE OF PRODUCTS;