























| No. | # | QYT / CANT. / QTÉ | Description / Descripción / Description | Image / Imagen / Image |
|-----|--|-------------------|--|---|
| 1 | | 1 | Main body with legs Cuerpo principal con patas Corps principal avec jambes |  |
| 2 | W-GD401103 | 4 | Caster Rueda Roulette |  |
| 3 | H-GD401104 | 2 | Leg bracket beam Barra del soporte de la pata Poutre de support de jambe |  |
| 4 | Z-GD401130 | 1 | Utensil rail Riel para utensilios Rail à ustensiles |  |
| 5 | W-CC115WT008 | 4 | "S" hook Gancho en forma de S Crochet en «S» |  |
| 6 | W-GD401102 | 1 | LP cylinder hook Gancho para bombona de gas Crochet de bouteille de gaz |  |
| 7 | W-GD401101 | 1 | LP cylinder base Base del bombona de gas Base de bouteille de gaz |  |
| 8 | H-GD401015 | 1 | Side table (L) Mesa lateral (I) Table d'appoint (G) |  |
| 9 | H-GD401105 | 1 | Side table (R) Mesa lateral (D) Table d'appoint (D) |  |
| 10 | W-20130012 | 2 | Flame tamer Regulador de llama Atténuateur de flamme |  |
| 11 | W-52930002 | 2 | Cooking grate Rejilla para asar Grille de cuisson |  |
| 12 | H-GD401003 | 1 | Cooking griddle Plancha superior Plaque de cuisson |  |
| 13 | H-GD402002 H-GD402003 H-GD402004 | 1 | Wind deflector Deflector de viento Deflecteur de vent |  |
| 14 | W-DXL12012 | 1 | Bottle opener Abridor de botella Ouvre-bouteille |  |
| 15 | ZH-GD401103 | 1 | Grease tray Bandeja de recogida de grasa Lèche-frite |  |
| 16 | Z-GD800109 | 1 | Grease cup Depósito de recogida de grasa Bac à graisse |  |

| Key / Clave / Réf. | Description / Descripción / Description | QTY / CANT. / QTÉ | Image / Imagen / Image |
|--------------------|---|-------------------|---|
| A | M6x12 | 14 |  |
| B | M5x12 | 12 |  |
| C | M4x8 | 2 |  |
| D | M6 | 4 |  |
| E | M6x40 | 4 |  |

| TOOLS REQUIRED / HERRAMIENTAS REQUERIDAS / OUTILS REQUIS | |
|---|---|
| Description / Descripción / Description | Image / Imagen / Image |
| Phillips screwdriver Destornillador phillips Tournevis phillips |  |

Before beginning assembly, make sure all parts are present. If any parts are missing or damaged, do not attempt to assemble the products. Contact customer service for replacement parts via telephone or email.

- Tools needed (not included): Phillips screwdriver
- Approximate assembly time: 30 minutes
- Note: The right and left sides of the griddle are designed as if you are facing the front of the griddle.

Antes de comenzar el montaje, asegúrese de que todas las piezas estén presentes. Si falta alguna pieza o está dañada, no intente ensamblar los productos. Póngase en contacto con el servicio de atención al cliente para obtener piezas de repuesto por teléfono o correo electrónico.

- Herramienta necesaria (no incluido): Destornillador phillips
- Tiempo aproximado de ensamblaje: 30 minutos
- Nota: Los lados derecho e izquierdo de la plancha están diseñados como si estuvieras frente a la parte delantera de la plancha.

Avant de commencer l'assemblage, assurez-vous que toutes les pièces sont présentes. Si des pièces sont manquantes ou endommagées, n'essayez pas d'assembler les produits. Contactez le service de clientèle pour les pièces de rechange par téléphone ou par e-mail.

- Outils nécessaires (non inclus): Tournevis phillips
- Temps nécessaire pour l'assemblage: 30 minutes
- Remarque: les côtés droit et gauche du plaque de cuisson sont conçus comme si vous faisiez face à l'avant du plaque de cuisson.

1

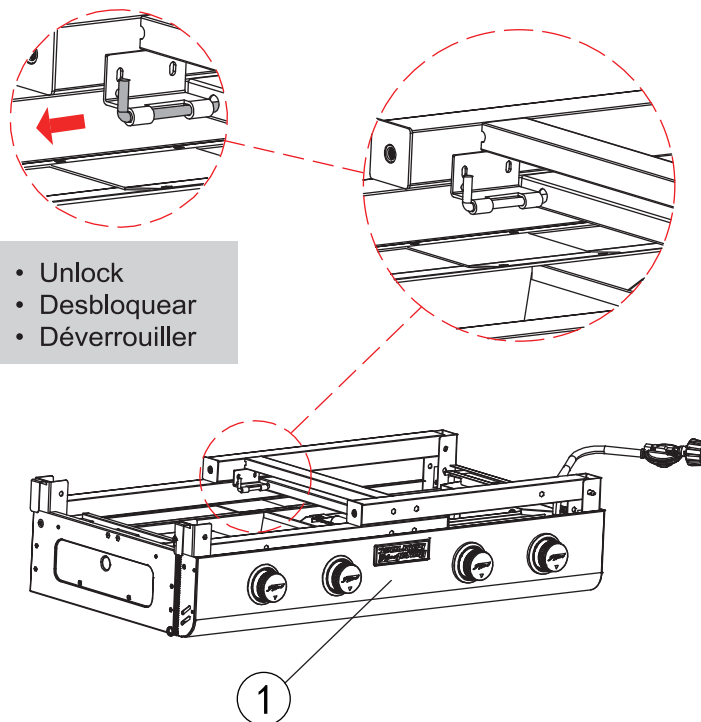

- Unlock
- Desbloquear
- Déverrouiller

2

A



×8

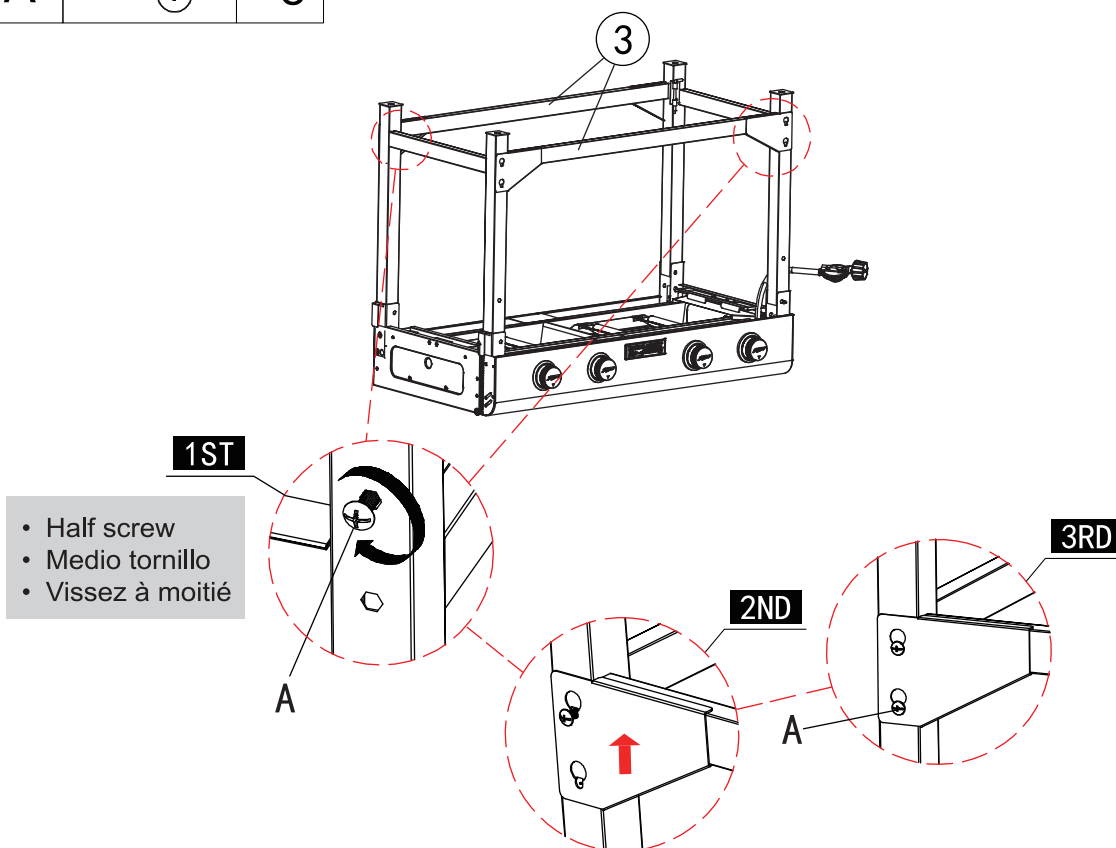

- Half screw
- Medio tornillo
- Vissez à moitié

3

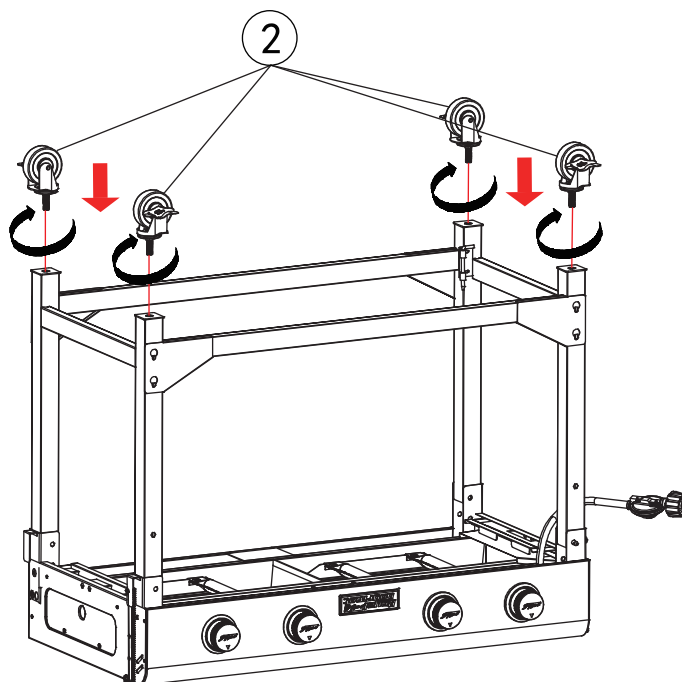

4 A  x2

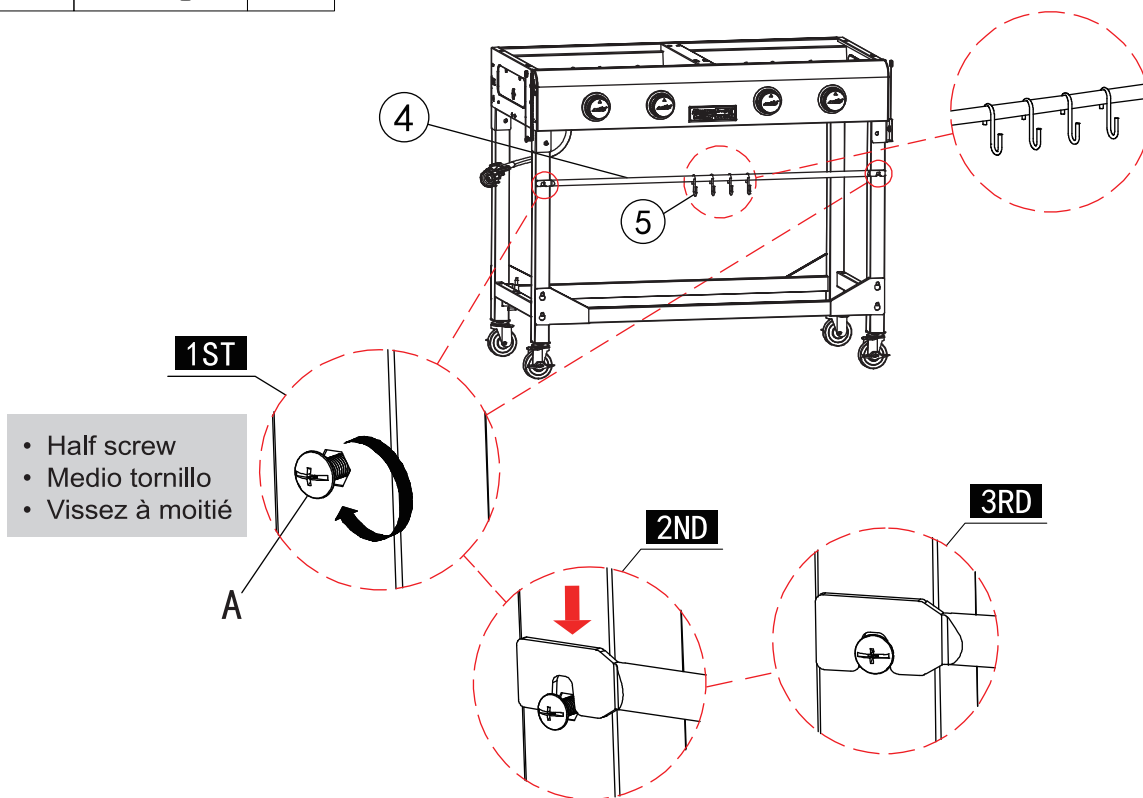

- Half screw
- Medio tornillo
- Vissez à moitié

5 A  ×4

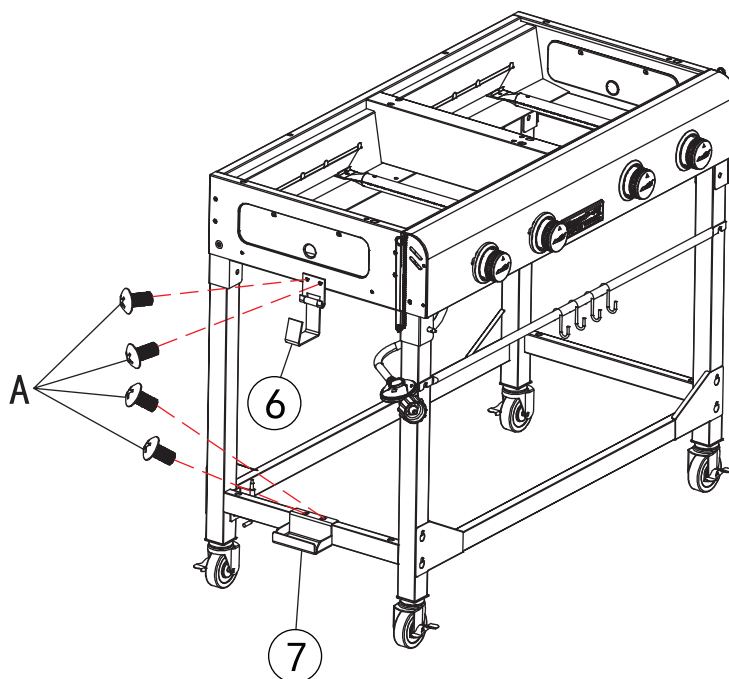

6 B  ×4

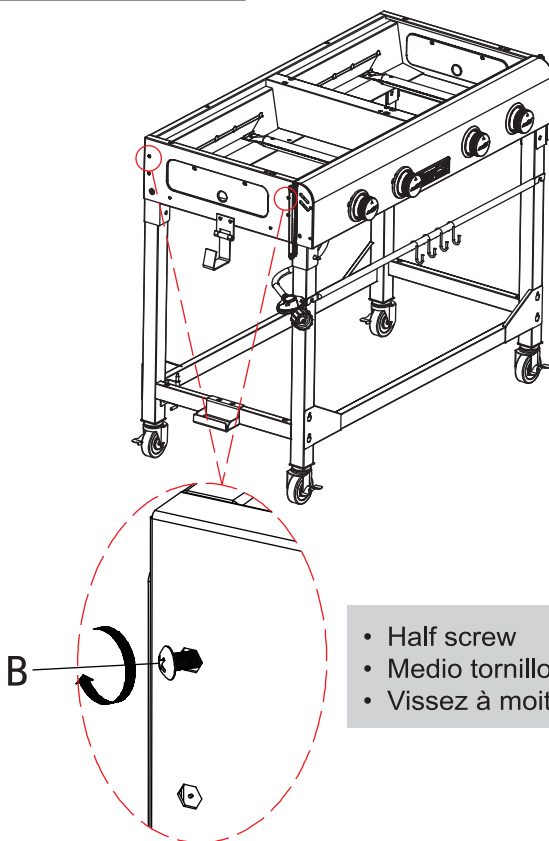

- Repeat for the other side.
- Repita esto paso para el otro lado.
- Répéter le étape pour l'autre côté.

- Half screw
- Medio tornillo
- Vissez à moitié

7

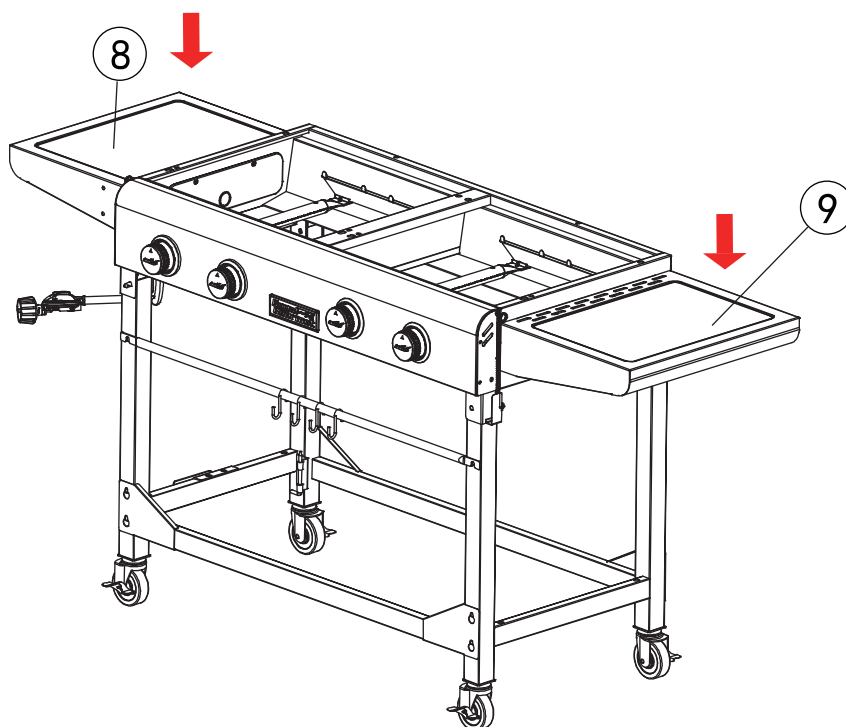

8 B  ×4

- Repeat for both side tables.
- Repita la operación con las dos mesas laterales.
- Répétez l'opération pour les deux tables d'appoint.

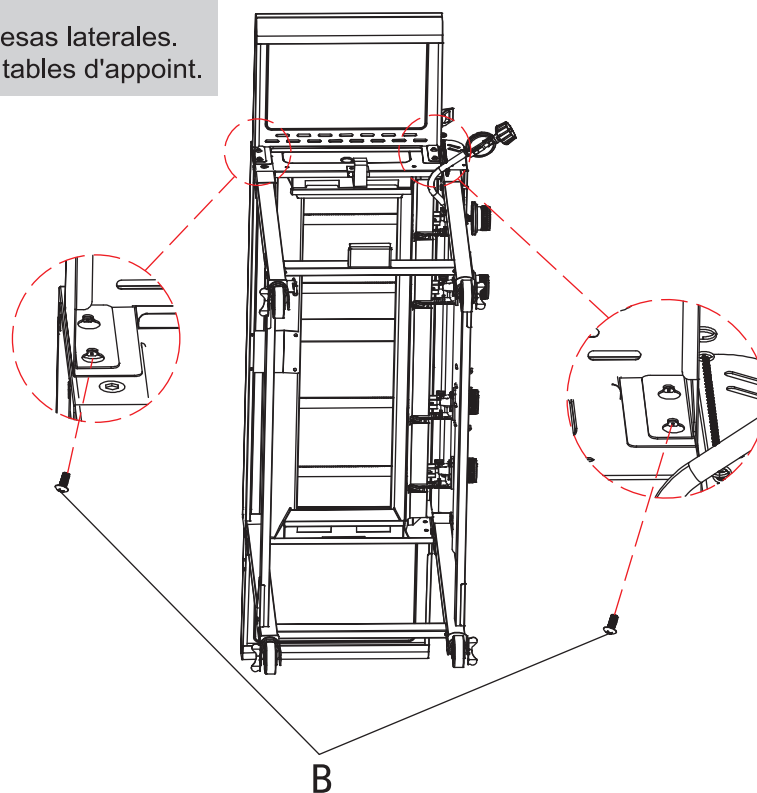

| | | | |
|----------|----------|---|-----------|
| 9 | B |  | ×4 |
|----------|----------|---|-----------|

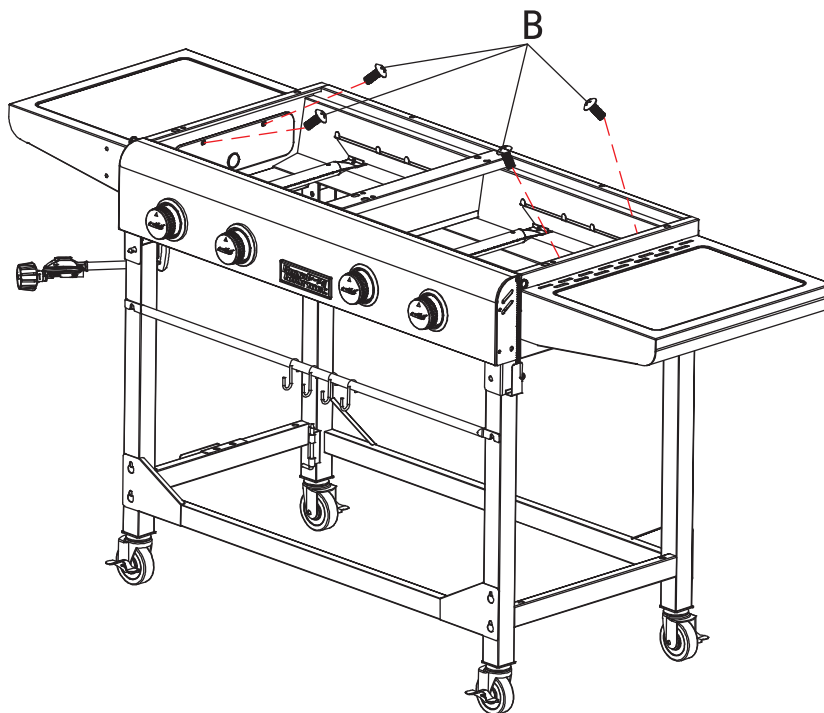

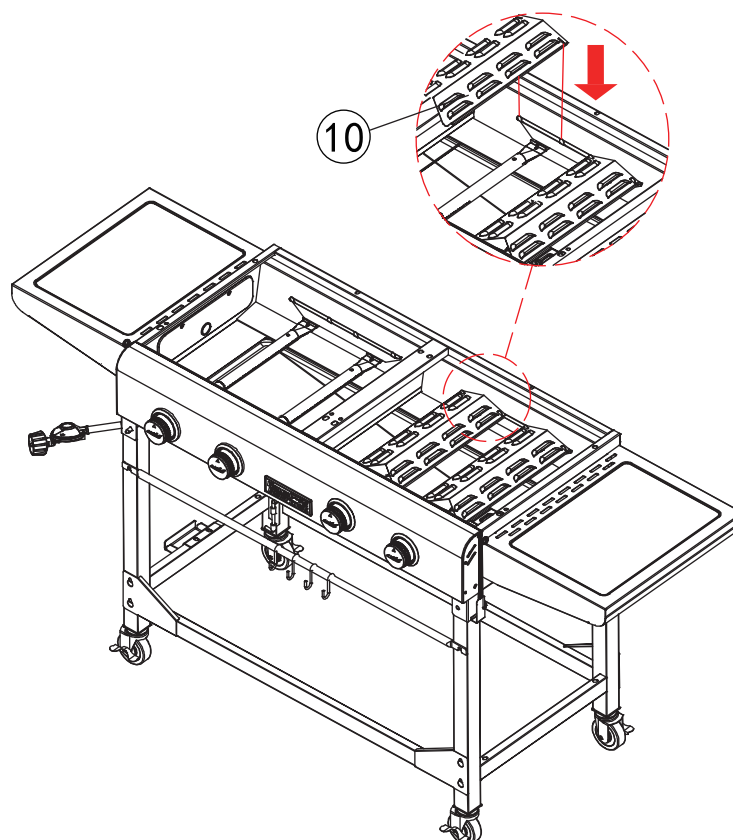

10

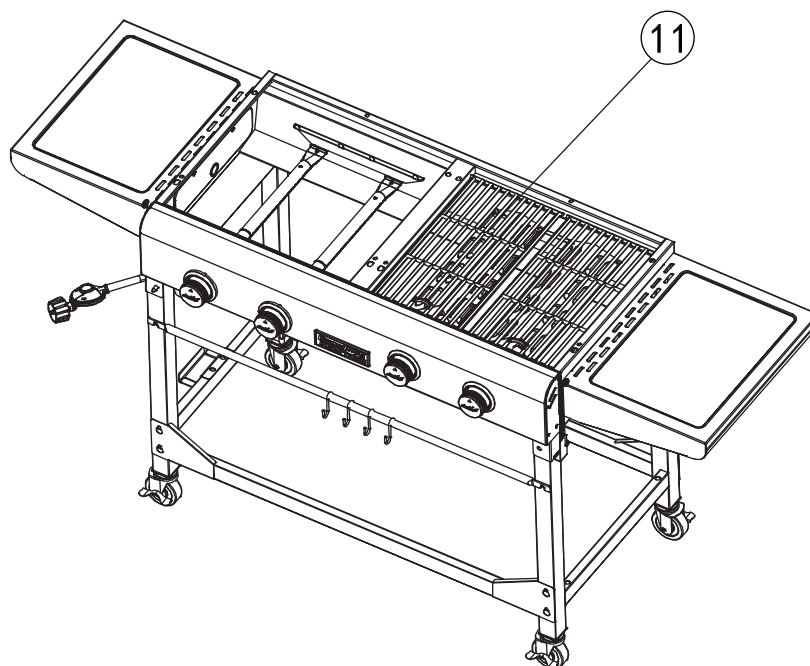

11



12

| | | |
|---|---|----|
| D |  | x4 |
| E |  | x4 |

- Adjust nuts to ensure the flatness of griddle.
- Ajustar las tuercas asegurando la planitud de la plancha.
- Ajustez les écrous pour assurer la planéité de la plaque.

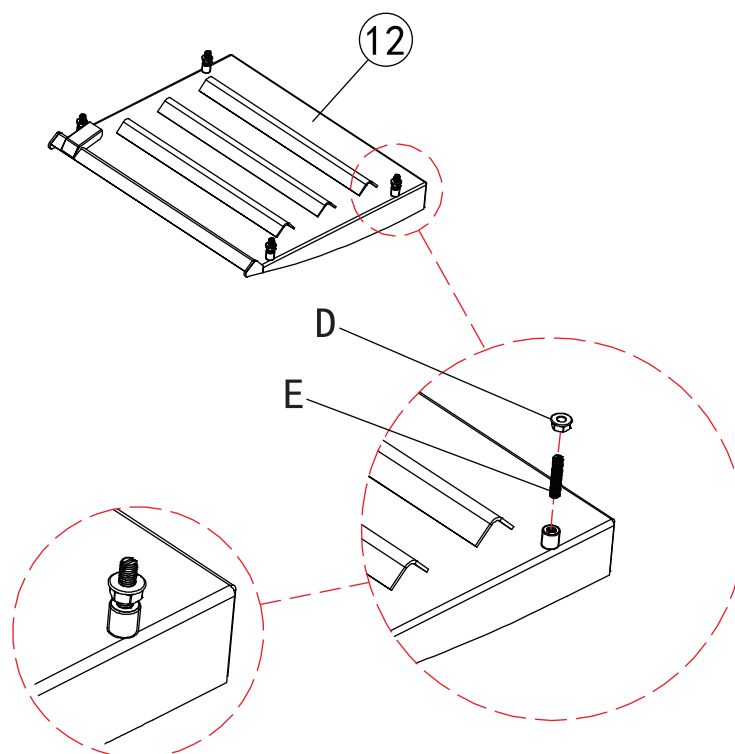

13

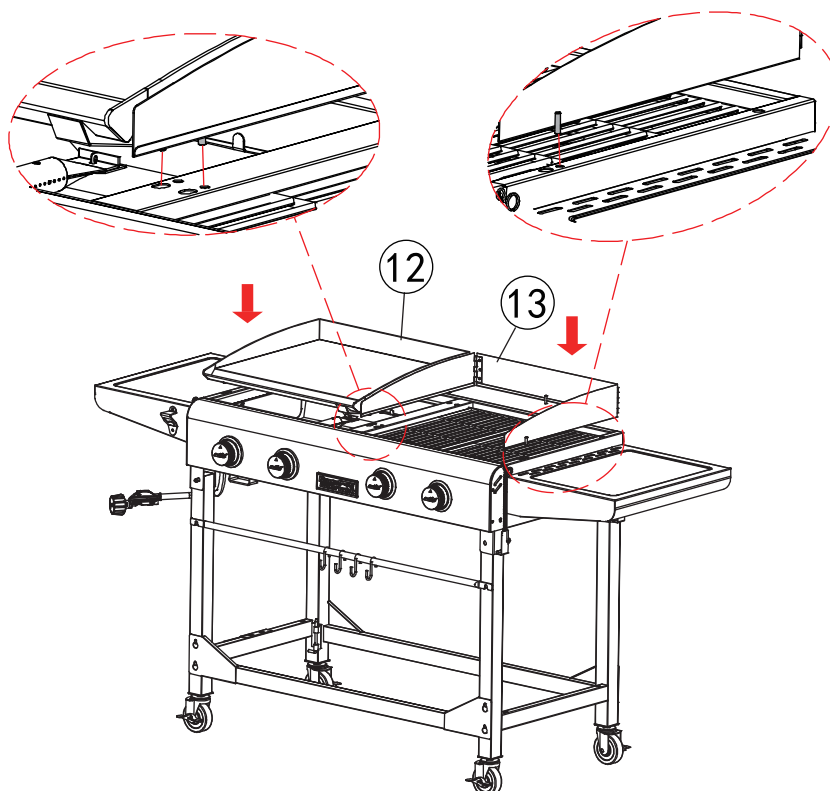

14

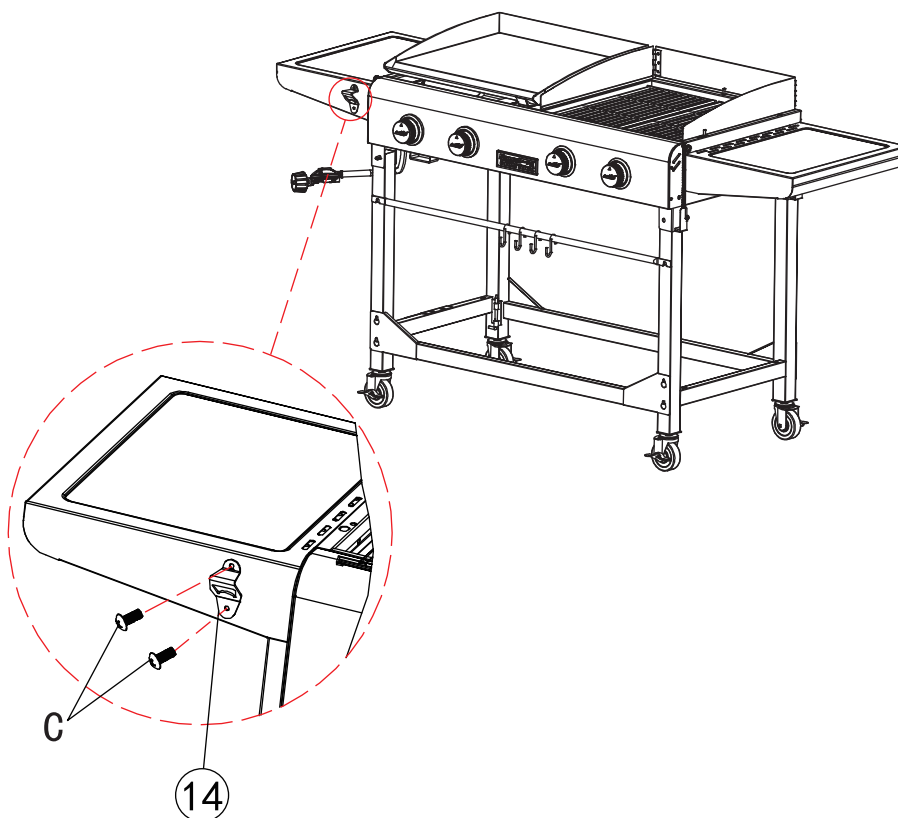
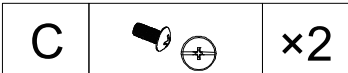

15

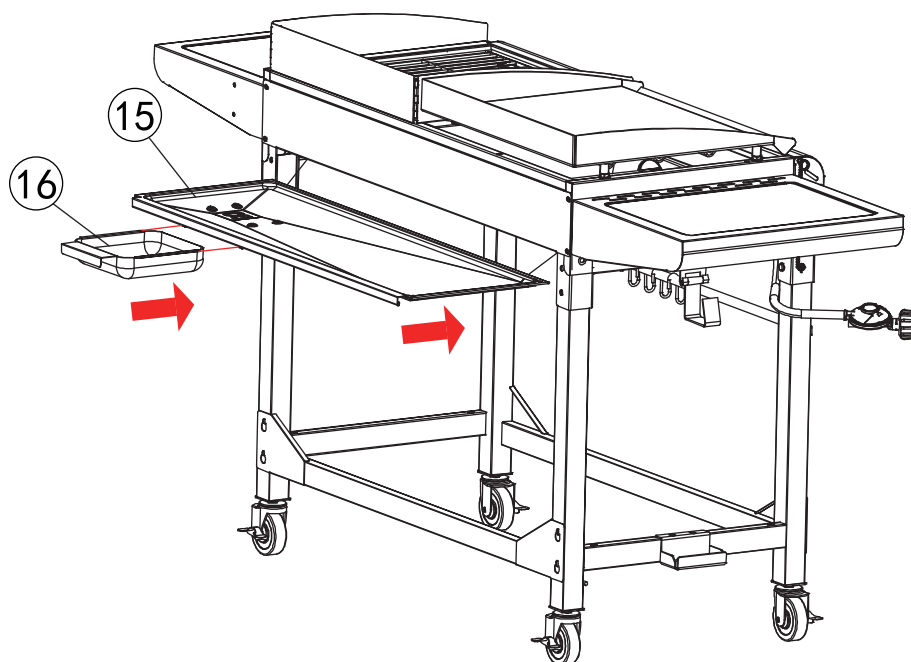

16

