

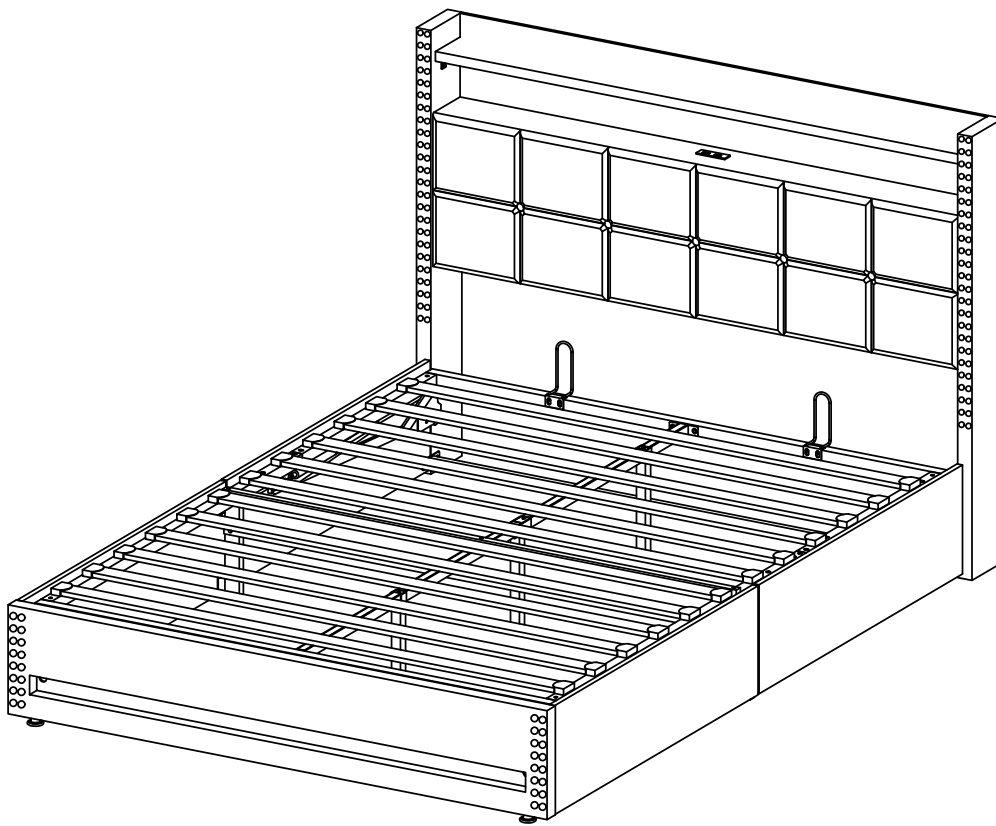

Upholstered Bed

N652P340000G

N652P340001G



TIPS

1. This product is divided into 2 parcels for delivery. They may not arrive at the same time. Please wait patiently.
2. Please read the instructions fully before assembly. These instructions include important information which could ensure correct assembly. We have been working on providing high quality products for you. However, in the rare instance that your product is defective, missing parts or there are some issues, please don't hesitate to contact our customer service to submit parts requirements, assembly suggestion, or warranty claims, and we will give the best solution as soon as possible. If necessary, we need you to provide some more clear pictures of the issue.
3. Insert the screws in holes and tighten the screws, but not too tight, 70%~80% is ok, finally tighten all the screws. If some issues happened that some screws can not target to the hole or some parts are difficult to install, please adjust the tightness of the screws.
4. 2 people are recommended to finish.

English

IMPORTANT FOR GAS LIFT BEDS&MAINTAINANCE

- Please place the mattress on top of the bed frame.
- Please do not pull on the strap handles.
- Please press heavily to release the compressed gas.
- Periodically check all screw & fixings to ensure they are secure.
- When moving your product, carefully lift into place.
- Wipe clean with a slightly damp cloth- please do not use abrasive chemicals or bleach.
- Do NOT allow children to operate the lift mechanism.
- Do NOT allow children near the lift base when operating the mechanism.
- Do NOT stand inside the bed or the internal storage base.
- Do NOT overload the internal storage base.
- DO NOT jump on the product or any of its parts.

Deutsch

WICHTIG FÜR GASLIFT-BETTEN&WARTUNG

- Bitte legen Sie die Matratze oben auf den Bettrahmen.
- Bitte ziehen Sie nicht an den Gurtgriffen.
- Bitte drücken Sie kräftig, um das komprimierte Gas freizusetzen.
- Überprüfen Sie regelmäßig alle Schrauben und Befestigungen, um sicherzustellen, dass sie sicher sind.
- Wenn Sie Ihr Produkt bewegen, heben Sie es vorsichtig an seinen Platz.
- Mit einem leicht feuchten Tuch abwischen - bitte keine scheuernden Chemikalien oder Bleichmittel verwenden.
- Erlauben Sie Kindern NICHT, den Hebemechanismus zu bedienen.
- Lassen Sie Kinder NICHT in die Nähe des Liftsockels, wenn Sie den Mechanismus bedienen.
- Stellen Sie sich NICHT in das Bett oder in die Innenablage.
- Überlasten Sie den internen Liftsockel NICHT.
- Springen Sie NICHT auf das Produkt oder eines seiner Teile.

Français

IMPORTANT POUR LES LITS À RELEVAGE DE GAZ&MAINTENANCE

- Veuillez placer le matelas sur le dessus du cadre de lit.
- Ne tirez pas sur les poignées de la sangle.
- Appuyez fortement pour libérer le gaz comprimé.
- Vérifiez régulièrement que toutes les vis et fixations sont bien en place.
- Lorsque vous déplacez votre produit, soulevez-le avec précaution pour le mettre en place.
- Nettoyez avec un chiffon légèrement humide - n'utilisez pas de produits chimiques abrasifs ou d'eau de Javel.
- Ne laissez pas les enfants utiliser le mécanisme de levage.
- Ne laissez pas les enfants s'approcher de la base de levage lorsqu'ils actionnent le mécanisme.
- Ne vous tenez PAS à l'intérieur du lit ou de la base de stockage interne.
- Ne surchargez pas la base de stockage interne.
- Ne pas sauter sur le produit ou l'une de ses parties.

Italiano

IMPORTANTE PER I LETTI CON SOLLEVAMENTO A GAS E LA MANUTENZIONE

- Posizionare il materasso sopra la struttura del letto.
- Non tirare le maniglie della cinghia.
- Premere con forza per rilasciare il gas compresso.
- Controllare periodicamente tutte le viti e i fissaggi per assicurarsi che siano saldi.
- Quando si sposta il prodotto, sollevarlo con cautela.
- Pulire con un panno leggermente umido, senza usare prodotti chimici abrasivi o candeggina.
- NON permettere ai bambini di azionare il meccanismo di sollevamento.
- NON permettere ai bambini di avvicinarsi alla base di sollevamento quando si aziona il meccanismo.
- NON sostare all'interno del letto o della base di contenimento interna.
- NON sovraccaricare la base di contenimento interna.
- NON saltare sul prodotto o sulle sue parti.

Español





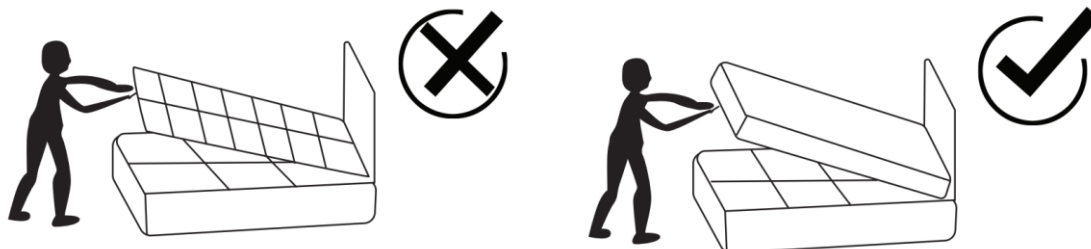

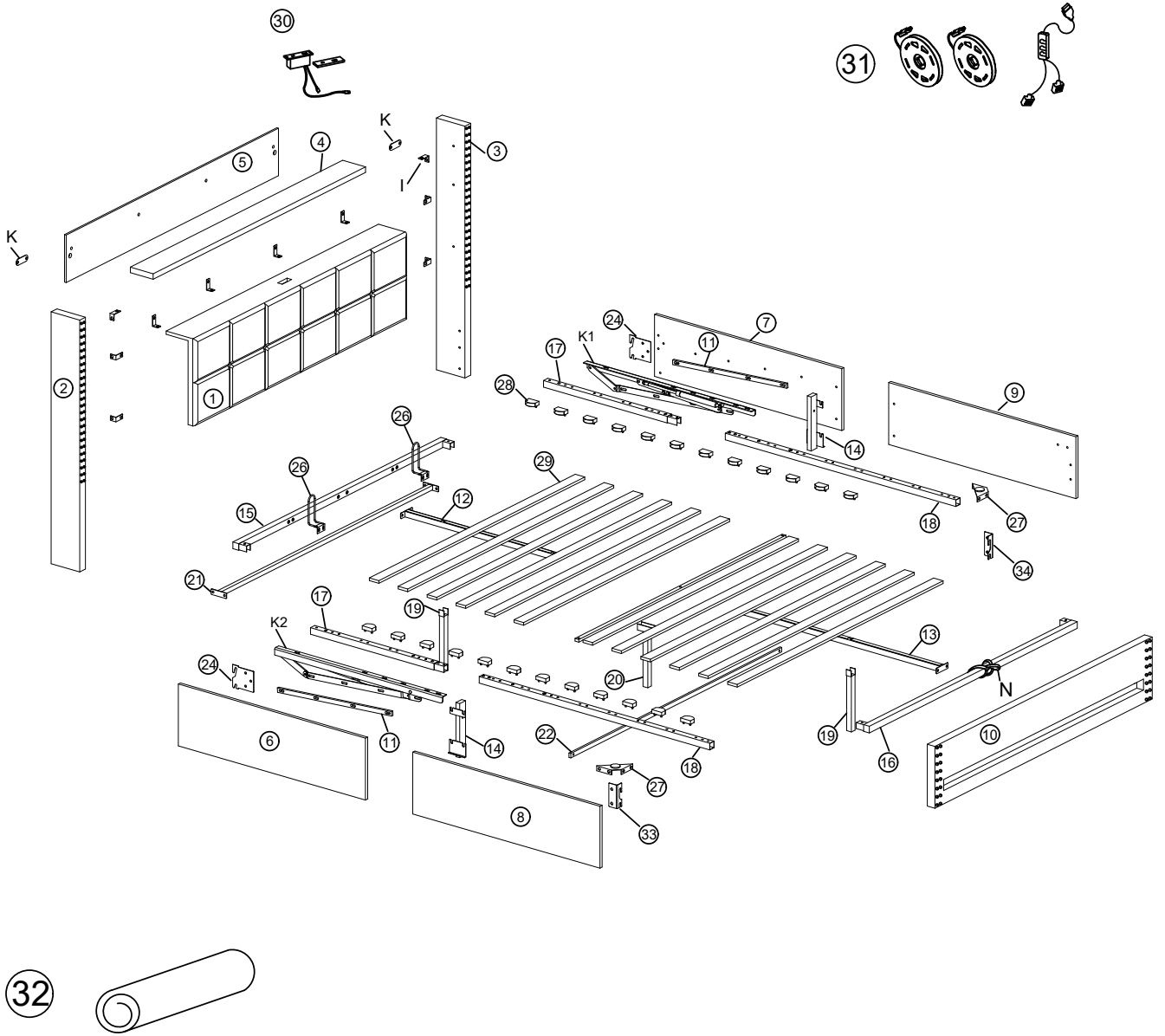

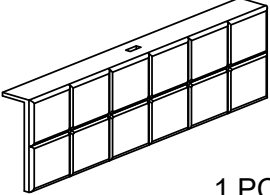
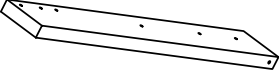

IMPORTANTE PARA LAS CAMAS ELEVADORAS DE GAS&MANTENIMIENTO

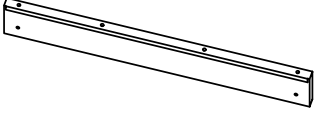
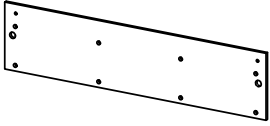
- Coloque el colchón sobre el somier.
- No tire de las asas de la correa.
- Presione con fuerza para liberar el gas comprimido.
- Compruebe periódicamente que todos los tornillos y fijaciones estén bien sujetos.
- Al mover el producto, levántelo con cuidado para colocarlo en su sitio.
- Limpie con un paño ligeramente humedecido; no utilice productos químicos abrasivos ni lejía.
- NO permita que los niños accionen el mecanismo de elevación.
- NO permita que los niños se acerquen a la base elevadora cuando accionen el mecanismo.
- NO se ponga de pie dentro de la cama o de la base de almacenamiento interna.
- NO sobrecargue el somier.
- NO salte sobre el producto ni sobre ninguna de sus piezas.

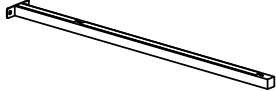

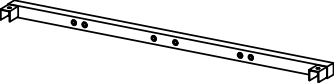
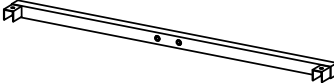
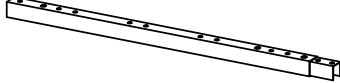
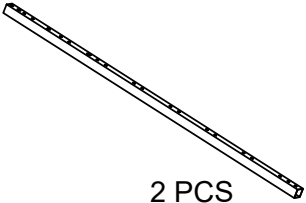
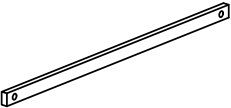
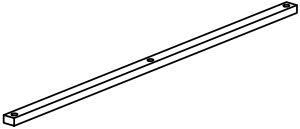

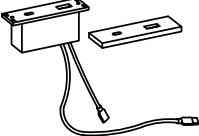













Parst List A box N652P340000G

<p>①</p>  <p>1 PC</p>	<p>②</p>  <p>1 PC</p>	<p>③</p>  <p>1 PC</p>	<p>④</p>  <p>1 PC</p>
<p>⑤</p>  <p>1 PC</p>	<p>⑪</p>  <p>2 PCS</p>	<p>⑫</p>  <p>1 PC</p>	<p>⑬</p>  <p>1 PC</p>
<p>⑮</p>  <p>1 PC</p>	<p>⑯</p>  <p>1 PC</p>	<p>⑰</p>  <p>2 PCS</p>	<p>⑱</p>  <p>2 PCS</p>
<p>⑳</p>  <p>1 PC</p>	<p>㉓</p>  <p>1 PC</p>	<p>㉘</p>  <p>24 PCS</p>	<p>㉚</p>  <p>1 PC</p>
<p>K2</p>  <p>1 PC</p>	<p>K1</p>  <p>1 PC</p>		







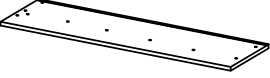
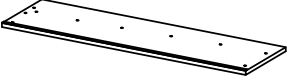

Hardware details B box

N652P340001G

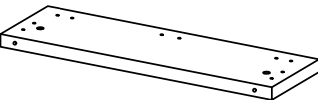
<p>(A) 64 PCS</p>  <p>M8x15 mm</p>	<p>(B) 7 PCS</p>  <p>M8x12 mm</p>	<p>(C) 14 PCS</p>  <p>M8x20 mm</p>	<p>(D) 15 PCS</p>  <p>M8x30 mm</p>	<p>(E) 5 PCS</p>  <p>M8x35 mm</p>
<p>(F) 11 PCS</p>  <p>M8x45 mm</p>	<p>(G) 9 PCS</p> 	<p>(H) 2 PCS</p>  <p>M3x15mm</p>	<p>(I) 10 PCS</p> 	<p>(J) 2 PCS</p> 
<p>(K) 2 PCS</p> 	<p>(L) 1 PC</p>  <p>D5</p>	<p>(M) 1 PC</p> 	<p>(N) 1 PC</p> 	

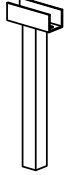
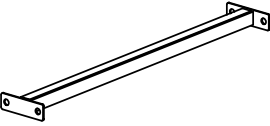

Parst List B box

N652P340001G

<p>(6)</p>  <p>1 PC</p>	<p>(7)</p>  <p>1 PC</p>	<p>(8)</p>  <p>1 PC</p>	<p>(9)</p>  <p>1 PC</p>
<p>(10)</p>  <p>1 PC</p>	<p>(14)</p>  <p>2 PCS</p>	<p>(19)</p>  <p>2 PCS</p>	<p>(20)</p>  <p>1 PC</p>
<p>(21)</p>  <p>1 PC</p>	<p>(24)</p>  <p>2 PCS</p>	<p>(25)</p>  <p>1 PC</p>	<p>(26)</p>  <p>2 PCS</p>

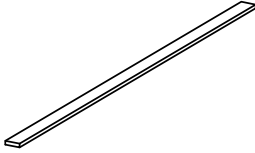
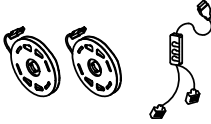
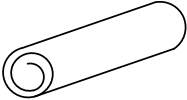

Parst List B box

N652P340001G

<p>27</p>  <p>2 PCS</p>	<p>29</p>  <p>12 PCS</p>	<p>31</p>  <p>1 PC</p>	<p>32</p>  <p>1 PC</p>
<p>33</p>  <p>1 PC</p>	<p>34</p>  <p>1 PC</p>		

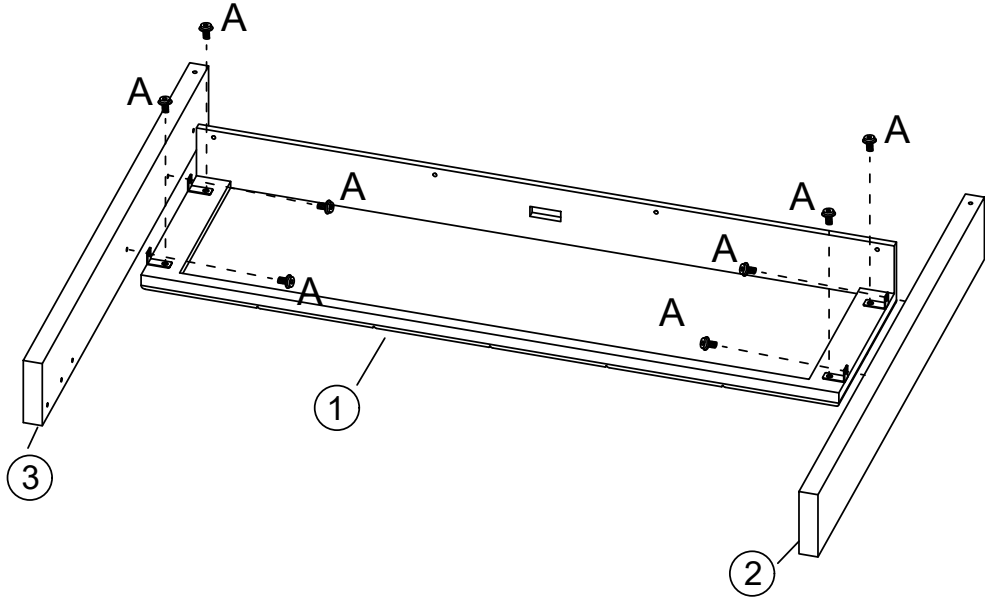
1



	A x 8PCS
	I x 4PCS

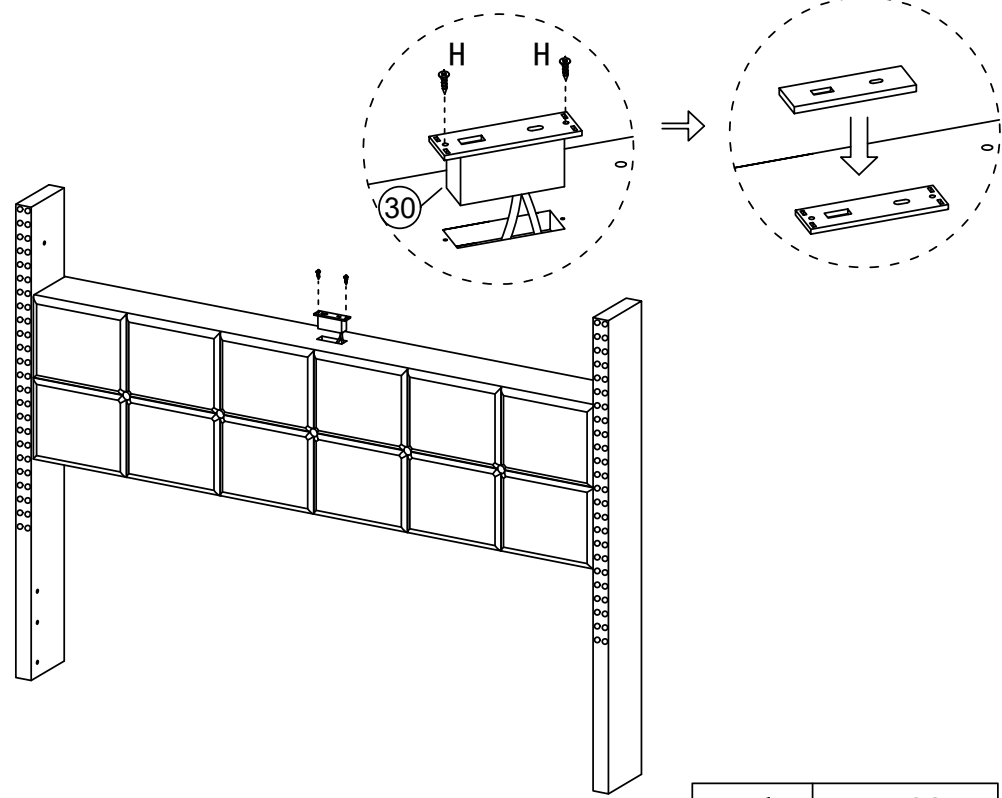

2



	H x 2PCS
---	----------

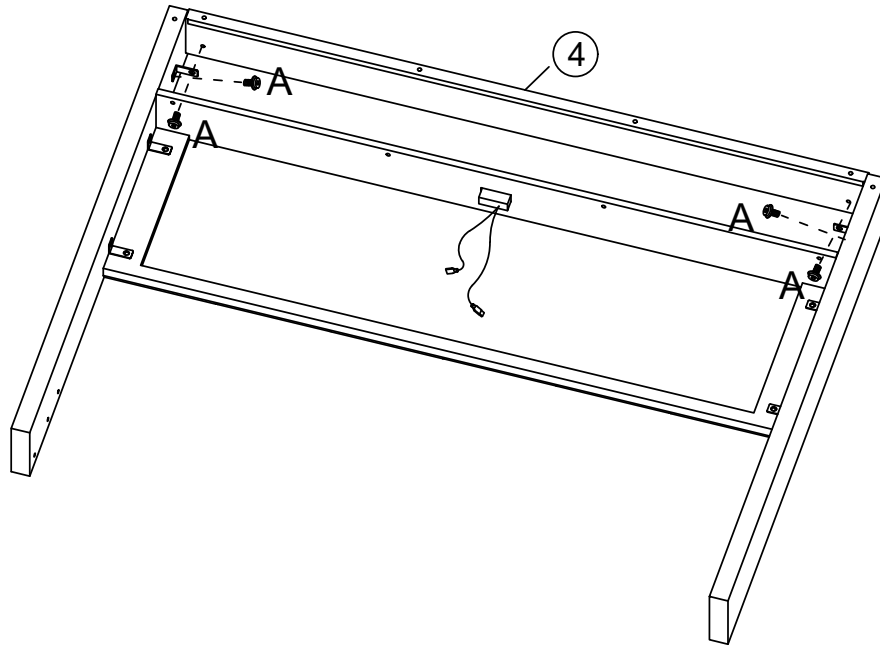





3

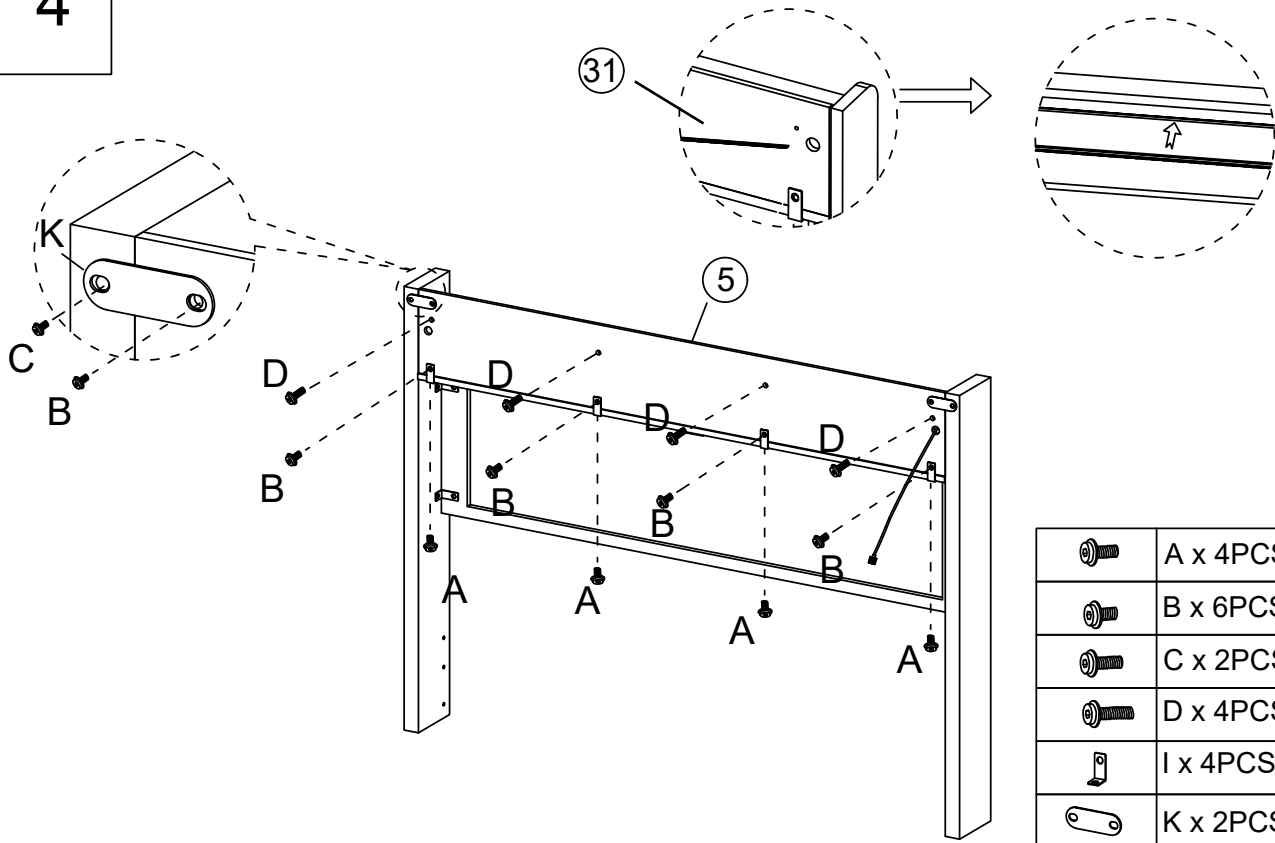

	A x 4PCS
	I x 2PCS

4



	A x 4PCS
	B x 6PCS
	C x 2PCS
	D x 4PCS
	I x 4PCS
	K x 2PCS

5

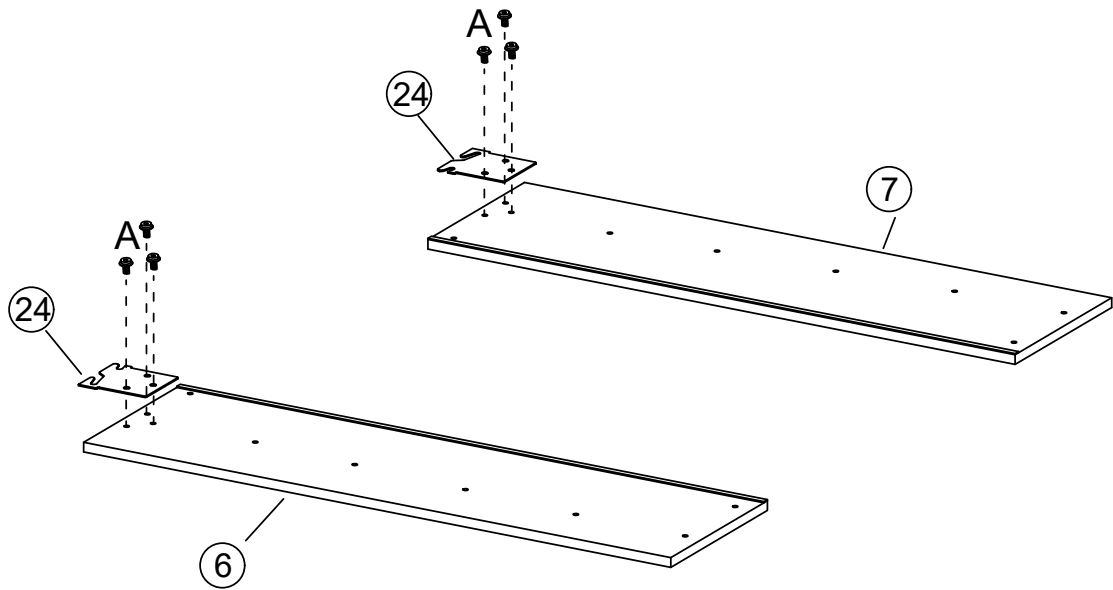

 A x 6PCS

6

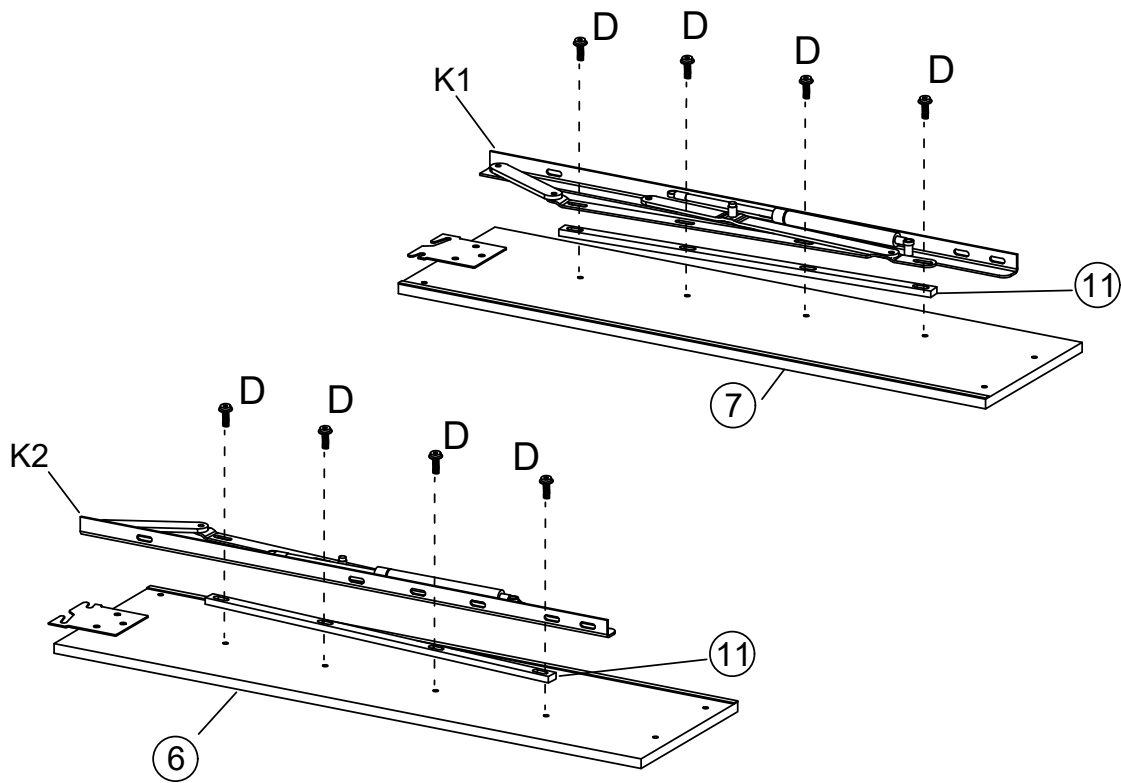

 D x 8PCS

7

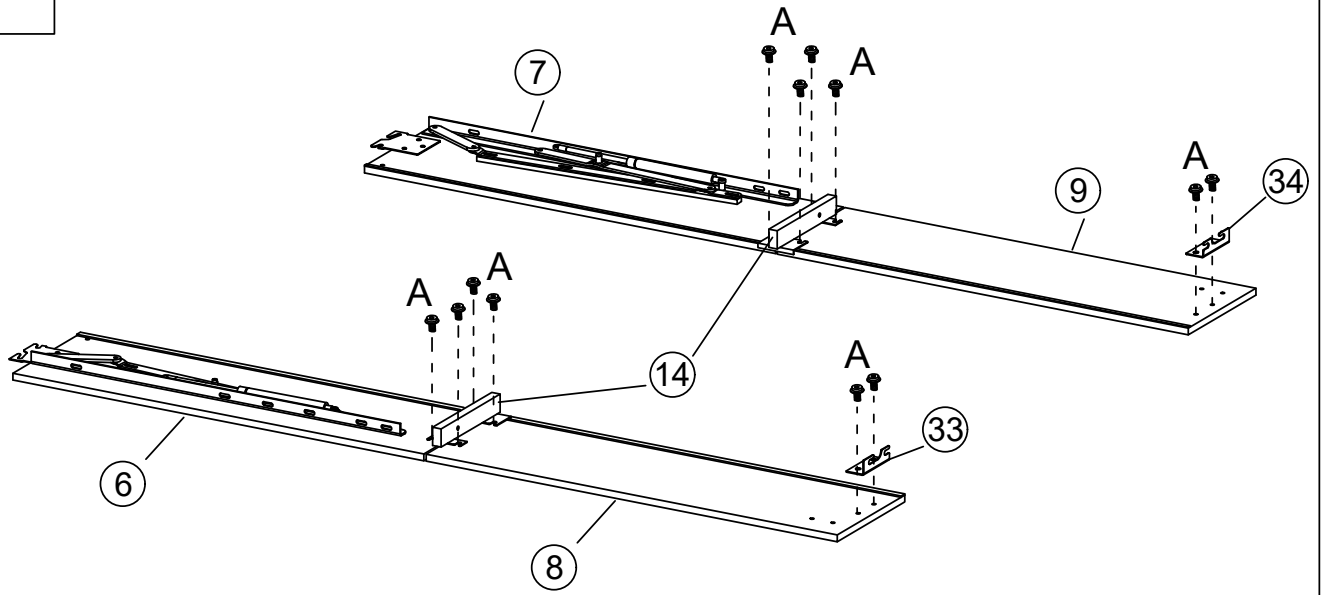

 A x 12PCS

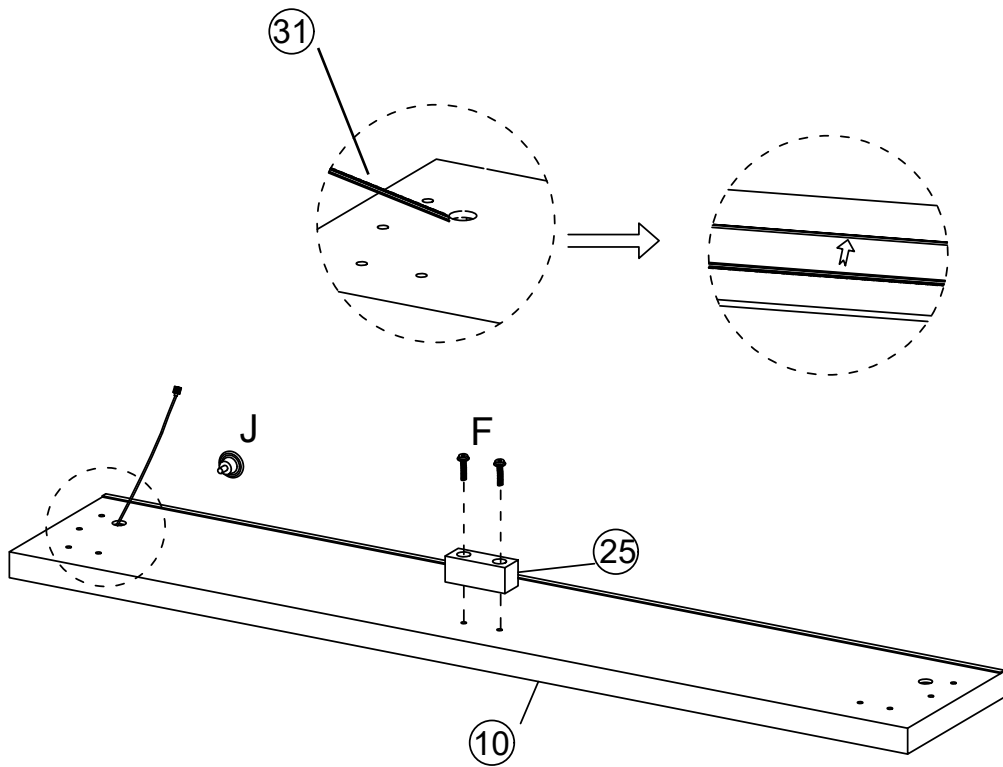

8

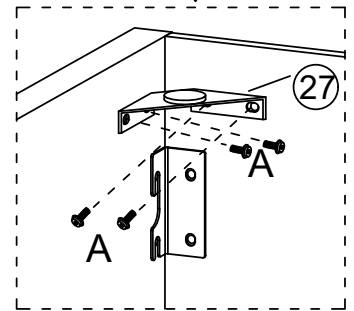
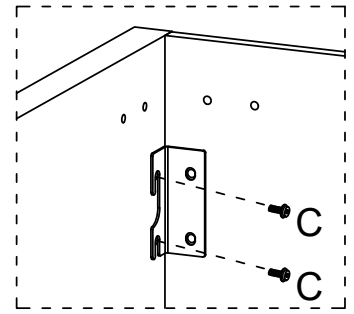
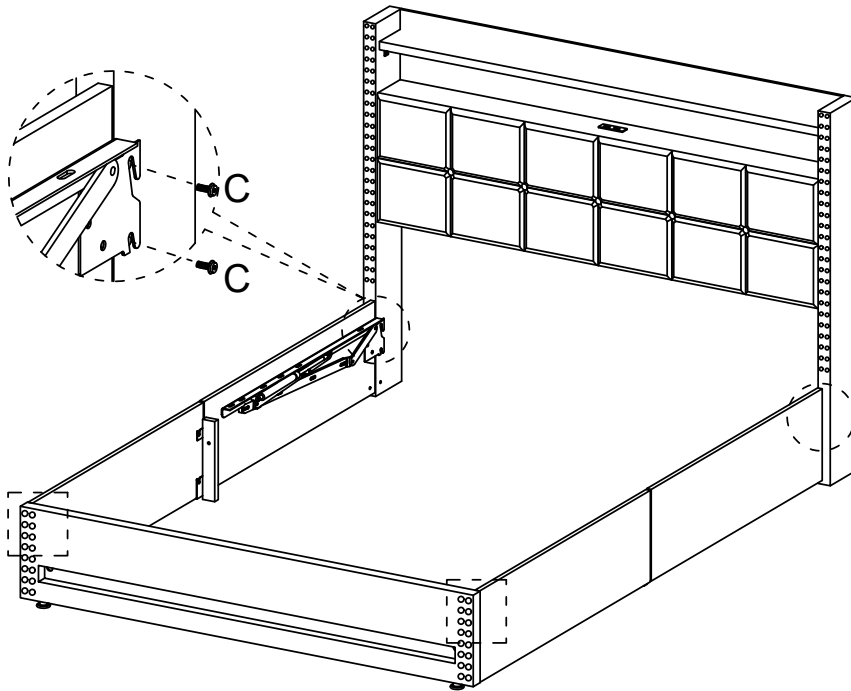

 F x 2PCS

9





	A x 8PCS
	C x 8PCS

10

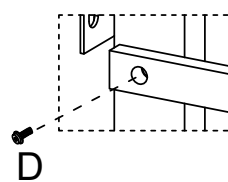
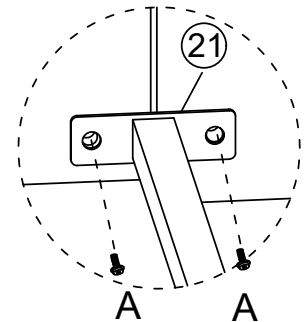
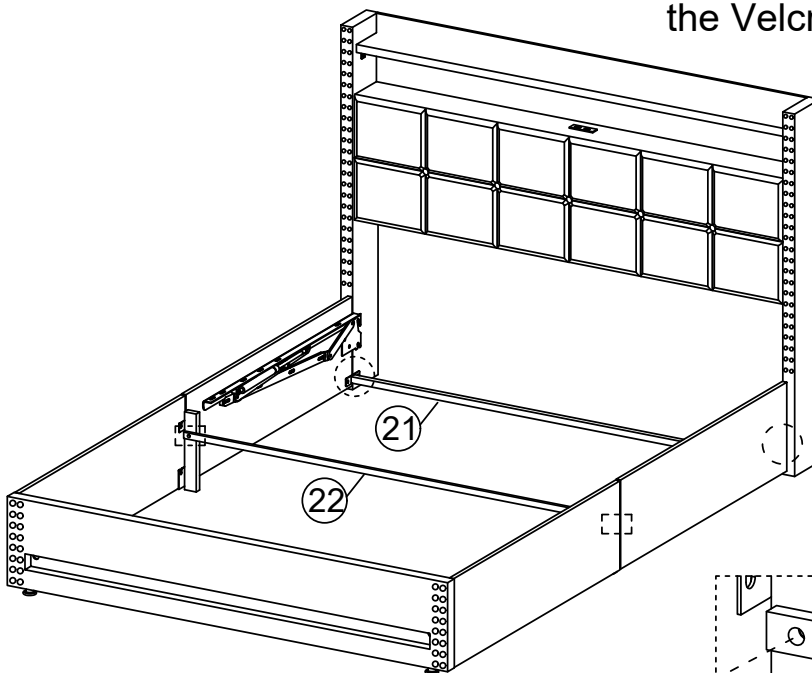
Place the NO.21 pipe fitting with the Velcro facing downwards.



	A x 4PCS
	D x 2PCS

11

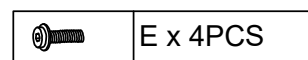
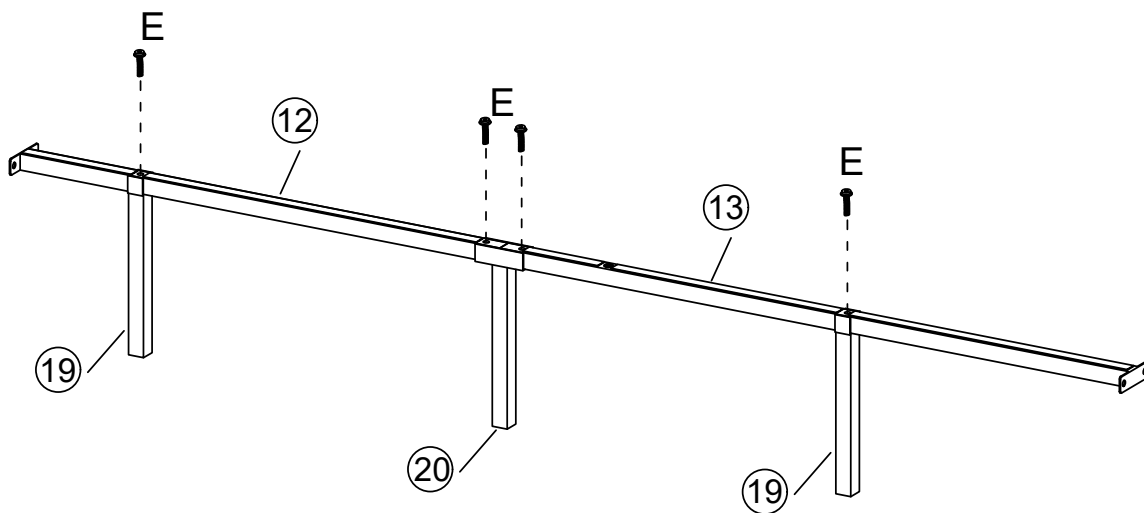

12

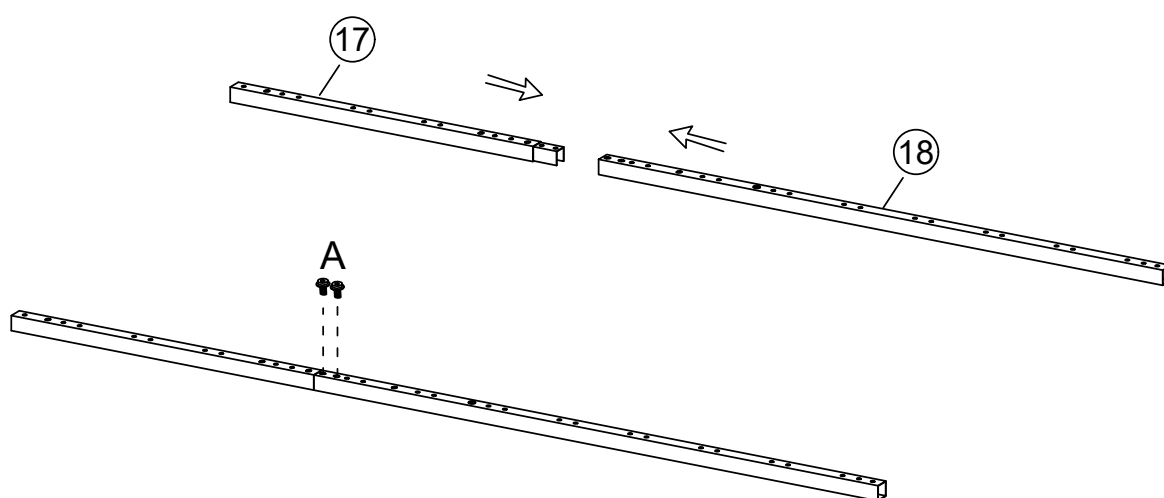

X2

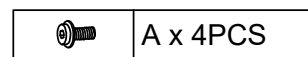

14

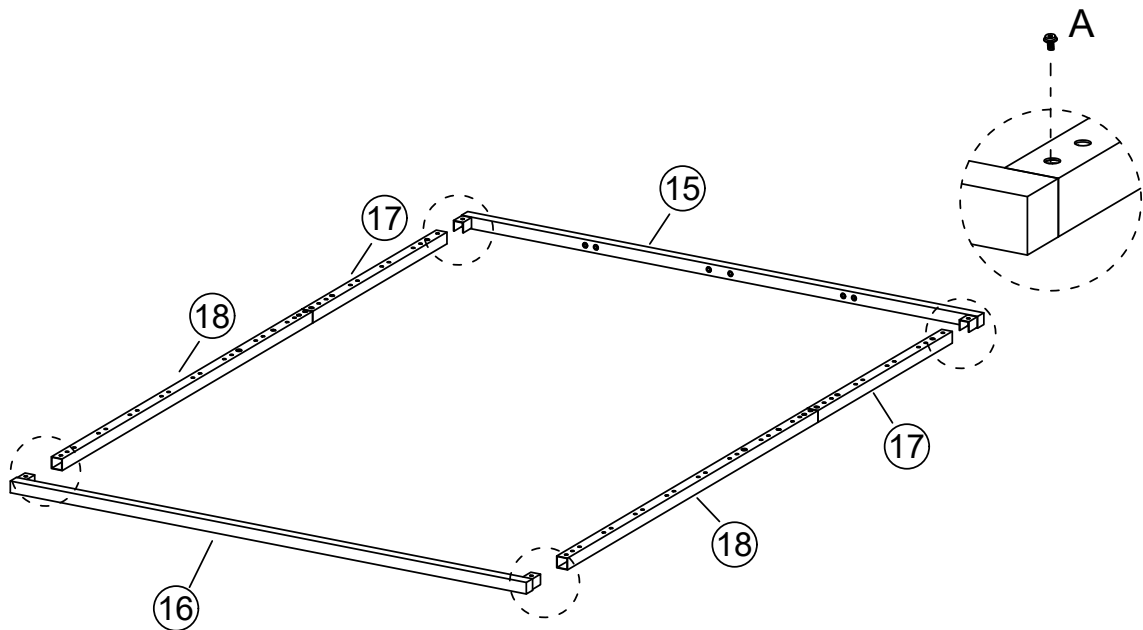

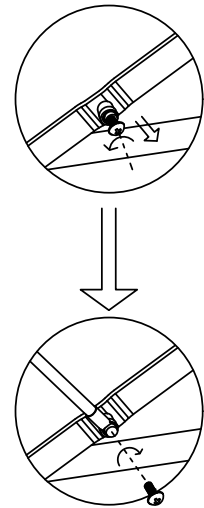
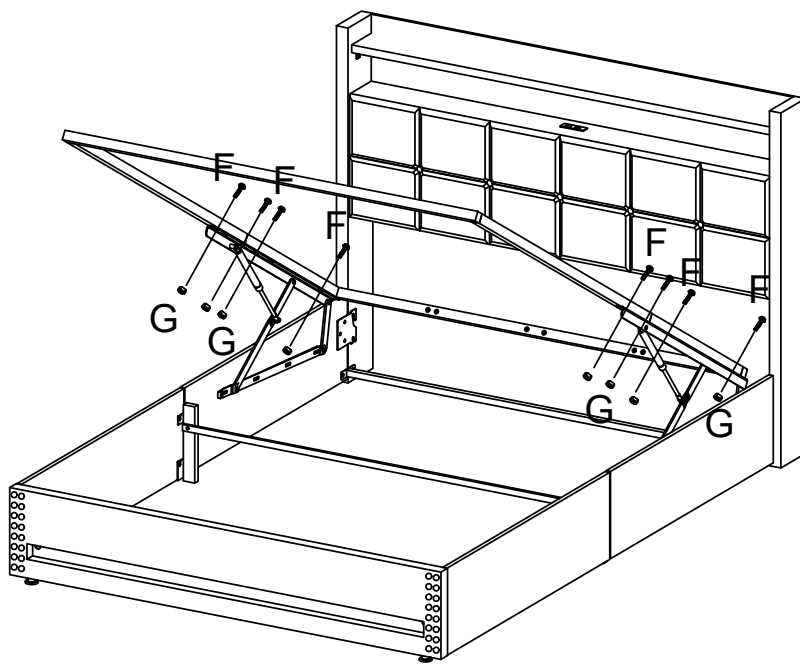

	A x 4PCS
--	----------

13





First, install the hydraulic rod.

	F x 8PCS
	G x 8PCS

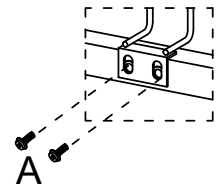
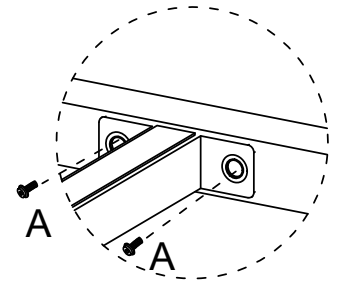
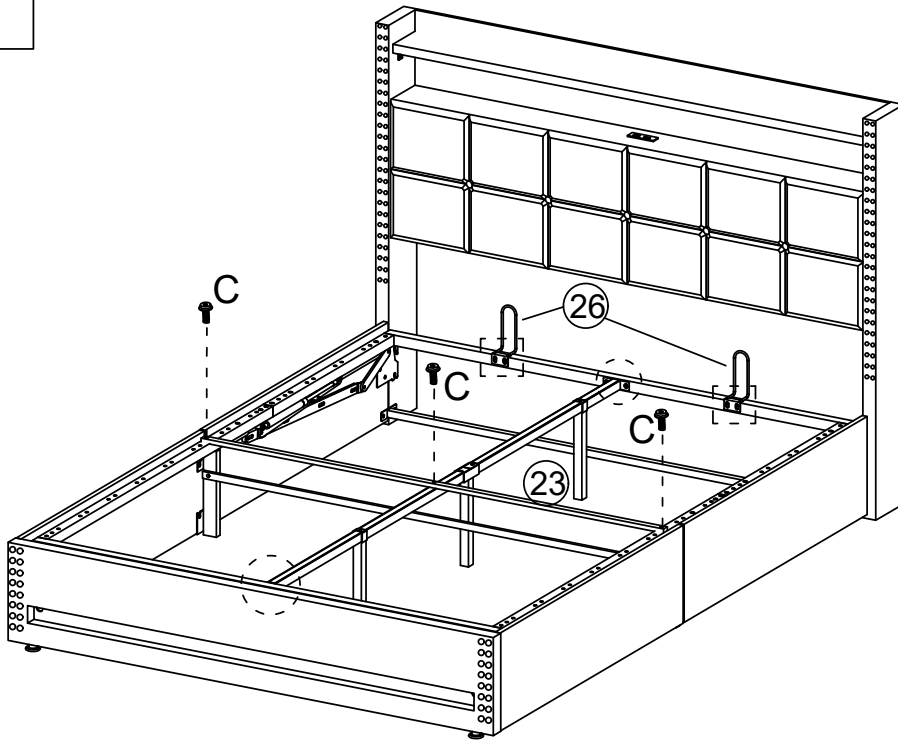
15



	A x 8PCS
	C x 3PCS

16

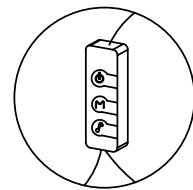
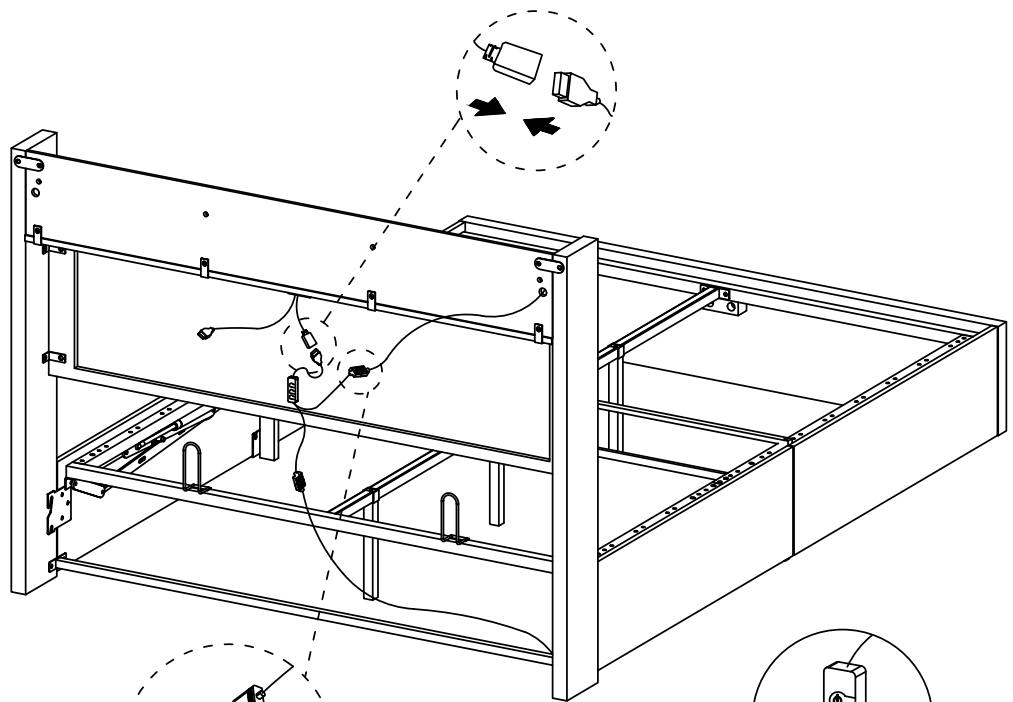



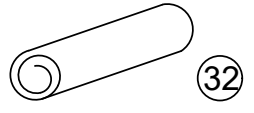
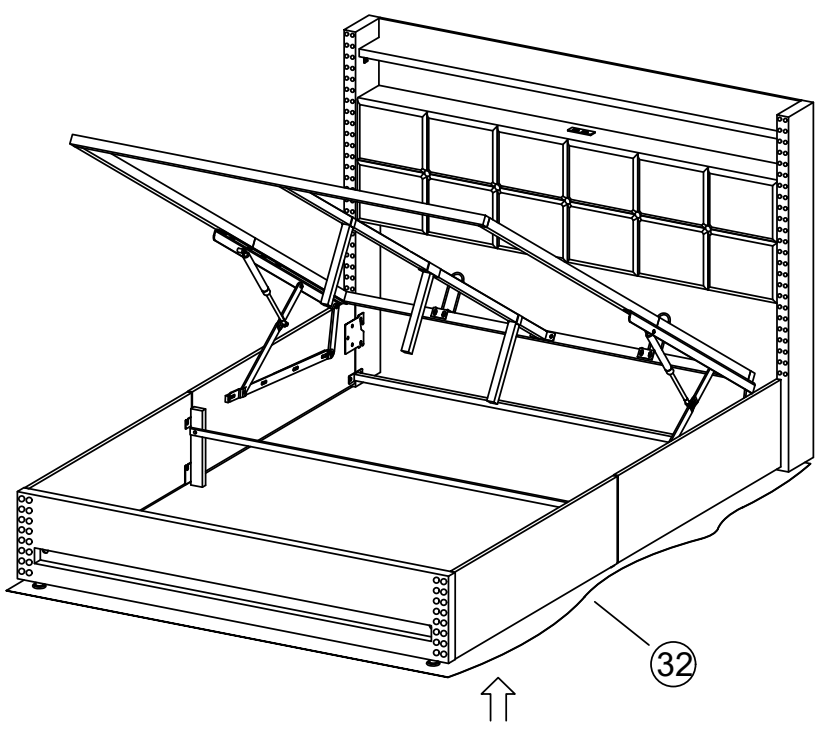

LED lamp button control.

17

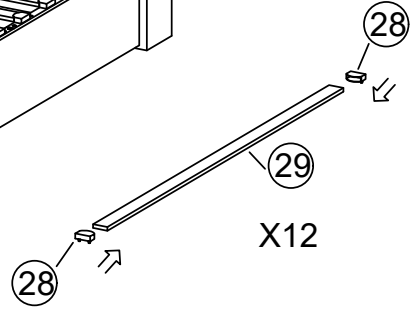
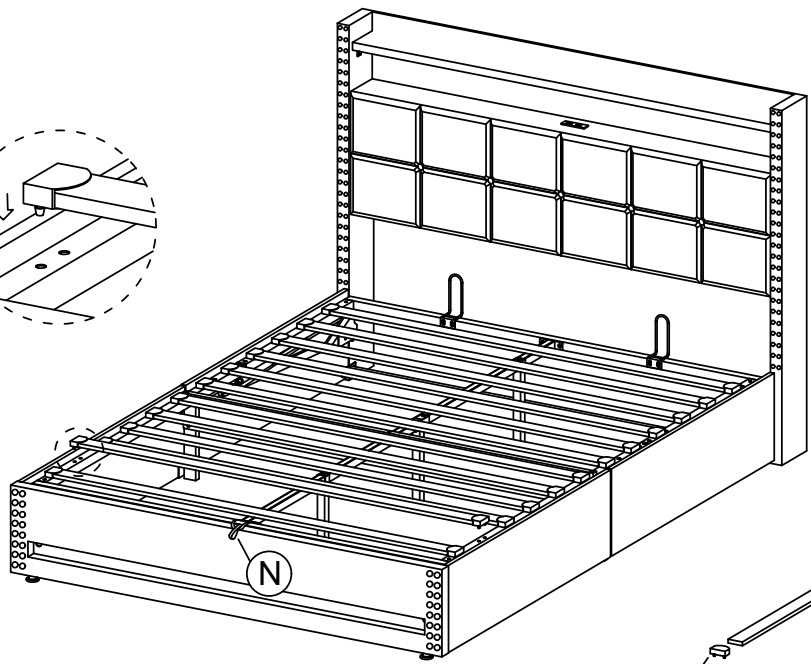
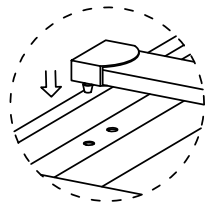

18



Importer	COMHARBOR LIMITED	
Add	Unit C, Swift Point,Cosford Lane,Rugby,CV21 1PY,GB	
Emai/URL	harborcomhar@gmail.com	
Manufacturer	Guangdong Zhangong EleCtriCal Technology Co.,Ltd	
Add	701,Building 29,zhifu Garden,Xingtan Town,ShundeDistrict,Foshan City	
Emai/URL	Chenweirong@zhangongsoCket,Com	
Product identification	202507	
Made in	China	
	COMHARBOR LIMITED Unit C, Swift Point, Cosford Lane,Rugby,CV211PY, GB harborcomhar@gmail.com	
 	Product Name:USB Hub/ CHARGER Model:ZG-USB-8 Rated voltage: 5V Rated frequency:50/60HZ Power:5V2A ≤10W	

Attestation of Compliance

Declaration No.: TMC210319128-E

Name and address of Applicant: **Shenzhen CWG Technology Co., Ltd**
5 / F, No.264 Baoshi East Road, Shiyan street, Bao'an District, Shenzhen,China
518108

Name and address of Manufacturer: **Shenzhen CWG Technology Co., Ltd**
5 / F, No.264 Baoshi East Road, Shiyan street, Bao'an District, Shenzhen,China
518108

Product name: **LED Strip**

Rated: DC12V
CWG-5050RGB-60D-12V, CWG-5050RGB-30D-12V , CWG-5050RGB-18D-12V,
CWG-5050RGB-60D-24V, CWG-5050RGB-60D-5V, CWG-5050RGB-30D-5V,
CWG-5050RGB-18D-5V, CWG-5050-60D-12V, CWG-5050-30D-12V,
CWG-5050-60D-24V, CWG-HC5050RGB-60D-12V,
CWG-HC5050RGB-30D-12V, CWG-HC5050RGB-60D-24V,
Product model(s): CWG-HC5050-60D-12V, CWG-HC5050-30D-12V, CWG-HC5050-60D-24V,
CWG-HC5050RGB-30D-5V, CWG-HC5050RGB-60D-5V,
CWG-HC5050RGB-144D-5V, CWG-2835-60D-12V, CWG-2835-120D-12V,
CWG-2835-60D-24V, CWG-2835-120D-24V, CWG-2835-60D-5V,
CWG-2835-120D-5V

Product trademark: 创唯光

This Attestation of Compliance confirms that the product meets the requirements of the following standard.

BS EN IEC 55015:2019+A11:2020

IEC 61547:2020

The Attestation of Compliance has been carried out in accordance with individual rules and conditions agreed with the applicant. Evaluation has been carried out in accordance with:

Test report(s) No.: TMC210319128-E

Test conducted by: TMC Testing Services (Shenzhen) Co., Ltd.

Declaration issue date: March 26, 2021

Notes:

This Attestation of Compliance is issued according to the Great Britain legislation Electromagnetic Compatibility Regulations 2016 It confirms that the listed products complies with all essential requirements of the Regulations and applies only to the sample and its technical documentation to TMC Testing Services (Shenzhen) Co., Ltd. for testing.

After preparation of the necessary technical documentation (which must be kept for up to 10 years after the product is placed on the GB market) as well as the UK Declaration of Conformity, the required UKCA marking can be affixed on the product. Other relevant Regulations have to be observed.

TMC Testing Services (Shenzhen) Co., Ltd.

t:86-755-86642861 cert@tmc-lab.com www.tmc-lab.com

1st Floor, Block A1, Zone A, Xinshidai Gongrong Industrial Park, No. 2, Shihuan Road, Shiyan Street, Baoan District, Shenzhen, China



**UK
CA**