

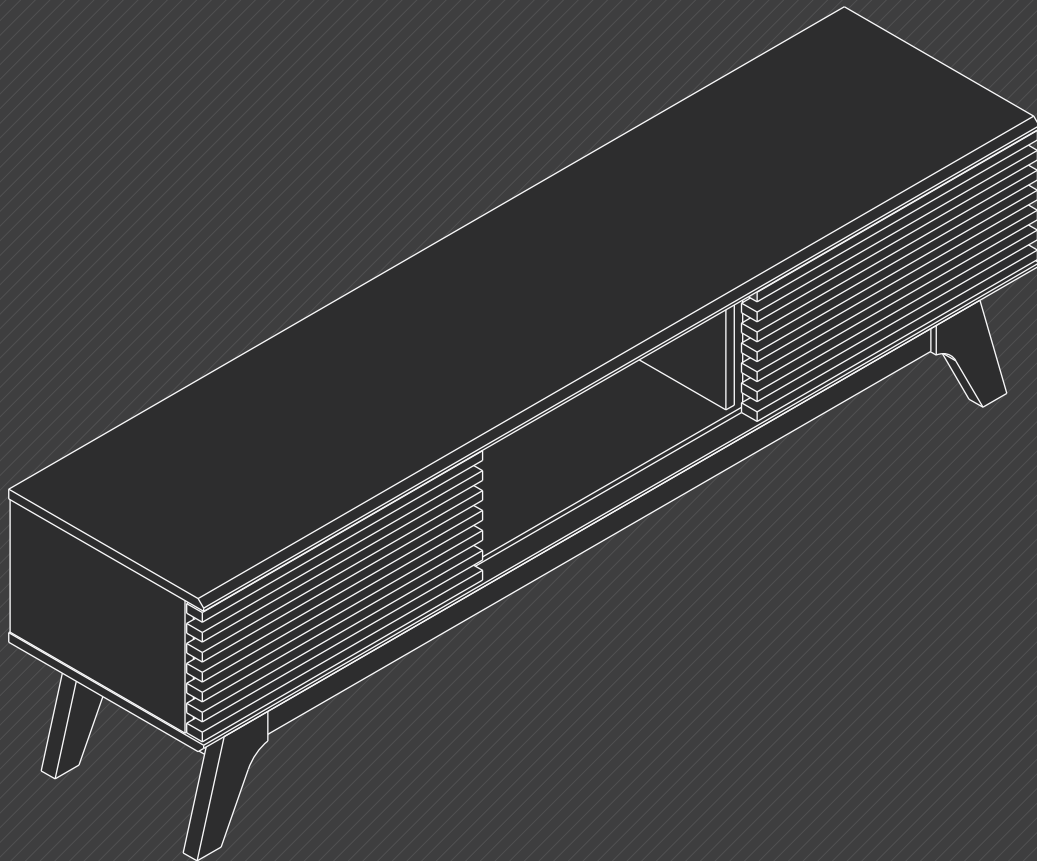

MID-CENTURY MODERN STYLE 2 SLIDING DOORS TV STAND



USER MANUAL



Contents

| TOPIC | | PAGE |
|-----------|--|--------------|
| 01 | SAFETY INSTRUCTIONS | 01-01 |
| | 1-1 Thank You For Choosing Our Product | 01 |
| | 1-2 Precautions | 01 |
| 02 | INSTALLING MODULES | 02-12 |
| | 2-1 Disassembly Diagram | 02 |
| | 2-2 Parts List | 03-04 |
| | 2-3 Assembly Instructions | 05-12 |
| 03 | CUSTOMER SERVICE | 13 |
| | 3-1 30-Day Return Policy | 13 |
| | 3-2 1-Year Warranty | 13 |
| | 3-3 Quick Response Within 24 Hours | 13 |
| 04 | PROBLEMS YOU MAY ENCOUNTER | 14 |
| | 4-1 Problems You May Encounter | 14 |

Safety Instructions

Thank You For Choosing Our Product

Before assembly, please read this USER MANUAL first, and check according to Parts List to make sure all parts are included. Feel free to contact us if you have any concerns or questions about your product, we are always ready to help. Your satisfaction is our first priority!

Precautions

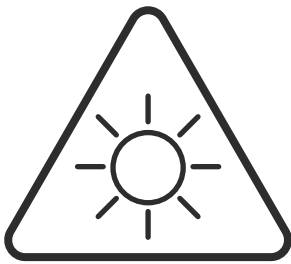

- Avoid long-term direct sunlight exposure.



- Keep away from sharp objects.

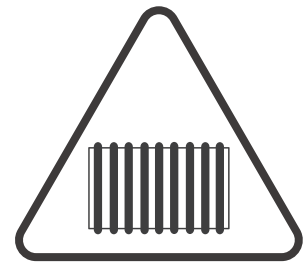

- Keep away from heat.

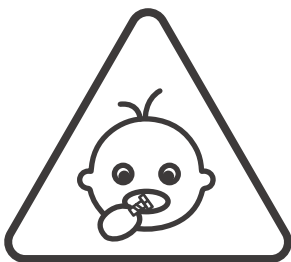

- Keep infants/children away from assembly parts to avoid choking and suffocation.



- Keep away from corrosive substances.

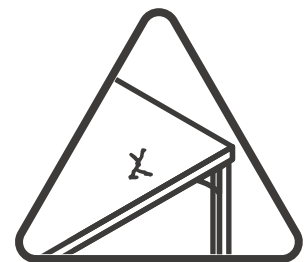

- Pay attention to avoid over-tightening fasteners, or they may induce cracking within the board.

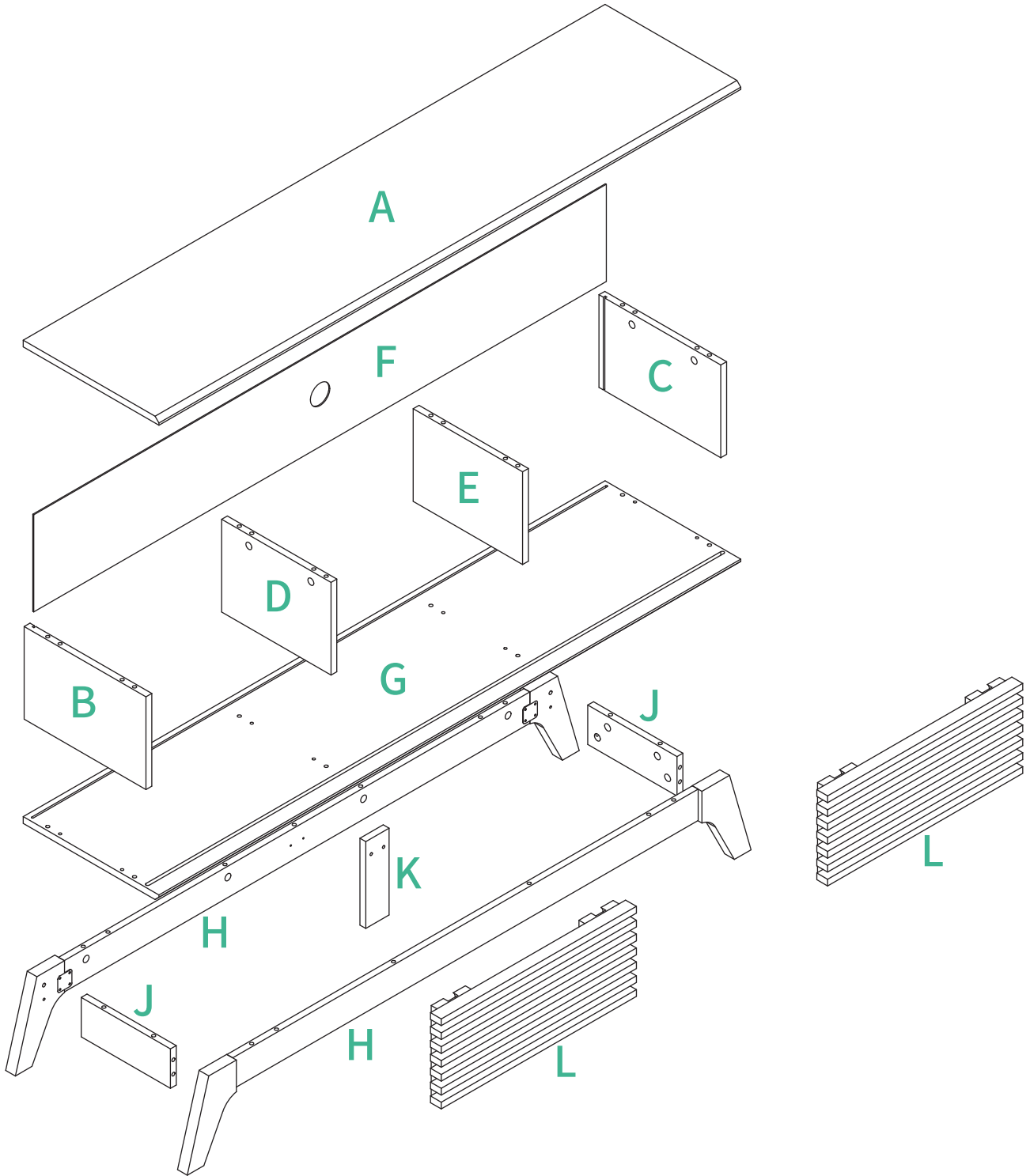

Disassembly Diagram

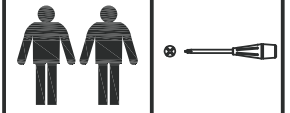

Parts List

For ease and safety, we recommend two people for assembly.

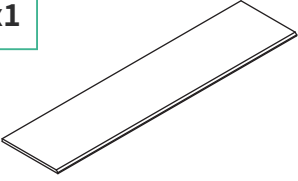
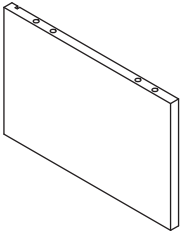
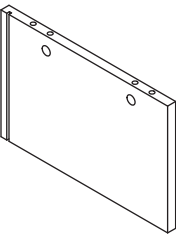
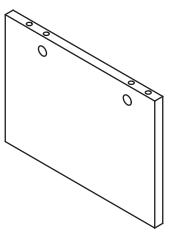
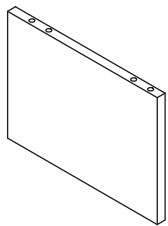
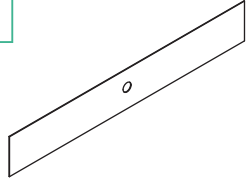
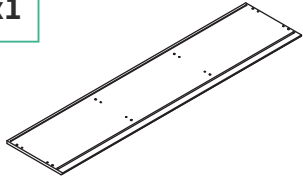
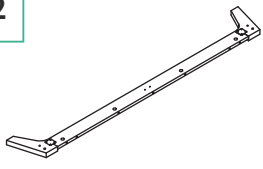
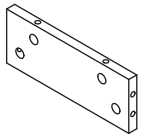

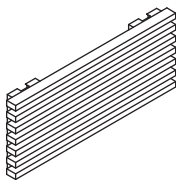

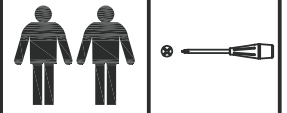

| | | | |
|---|---|--|--|
| A x1  | B x1  | C x1  | D x1  |
| E x1  | F x1  | G x1  | H x2  |
| J x2  | K x1  | L x2  | |

Parts List

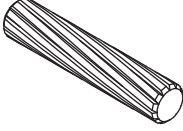
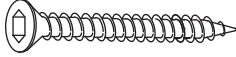
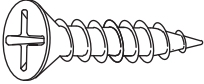
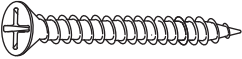
For ease and safety, we recommend two people for assembly.

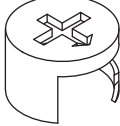
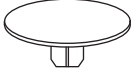

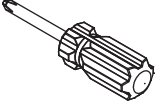
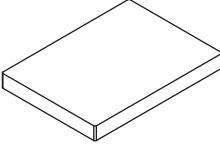
| | | | |
|--|--|---|--|
| <p>1 x27</p>  <p>3 Spares</p> | <p>2 x29</p>  <p>3 Spares</p> <p>M8x30</p> | <p>3 x9</p>  <p>1 Spare</p> <p>M6x50</p> | <p>4 x18</p>  <p>2 Spares</p> <p>M3x12</p> |
| <p>5 x3</p>  <p>1 Spare</p> <p>M4x30</p> | <p>6 x4</p>  <p>6-a 6-b</p> | <p>7 x27</p>  <p>3 Spares</p> | <p>8 x27</p>  <p>3 Spares</p> |
| <p>9 x2</p>  <p>1 Spare</p> | <p>10 x1</p>  | <p>11 x6</p>  <p>1 Spare</p> | |

Assembly Instructions

When installing, please lay soft pad on the ground to avoid scratch product.

1

Before assembling the product, please pre-assemble accessories ①. Please install each accessory correctly as shown in the diagram.

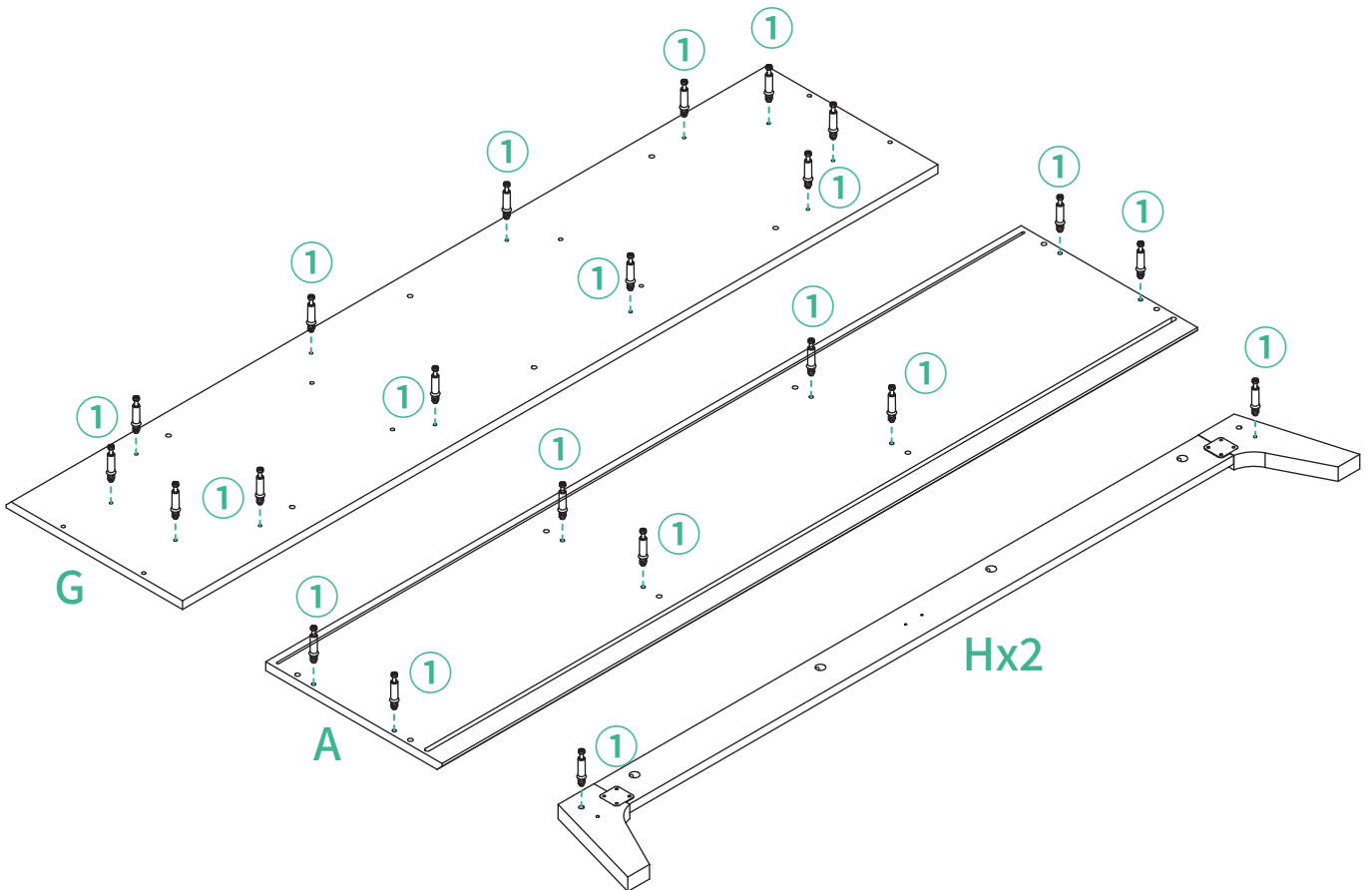
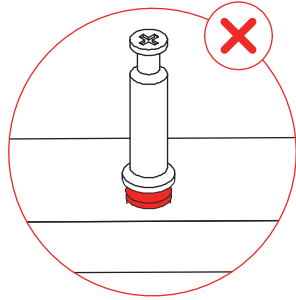
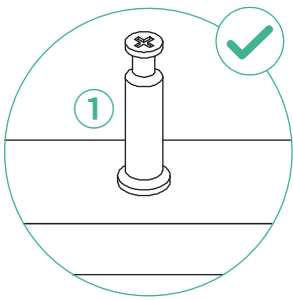

| | | | | | | | | | |
|----------------|--|----------------|--|----------------|--|-----------------|--|-----------------|--|
| A x1 | | G x1 | | H x2 | | 1 x24 | | 10 x1 | |
|----------------|--|----------------|--|----------------|--|-----------------|--|-----------------|--|

Assembly Instructions

2

Before assembling the product, please pre-assemble accessories ②. Please install each accessory correctly as shown in the diagram.

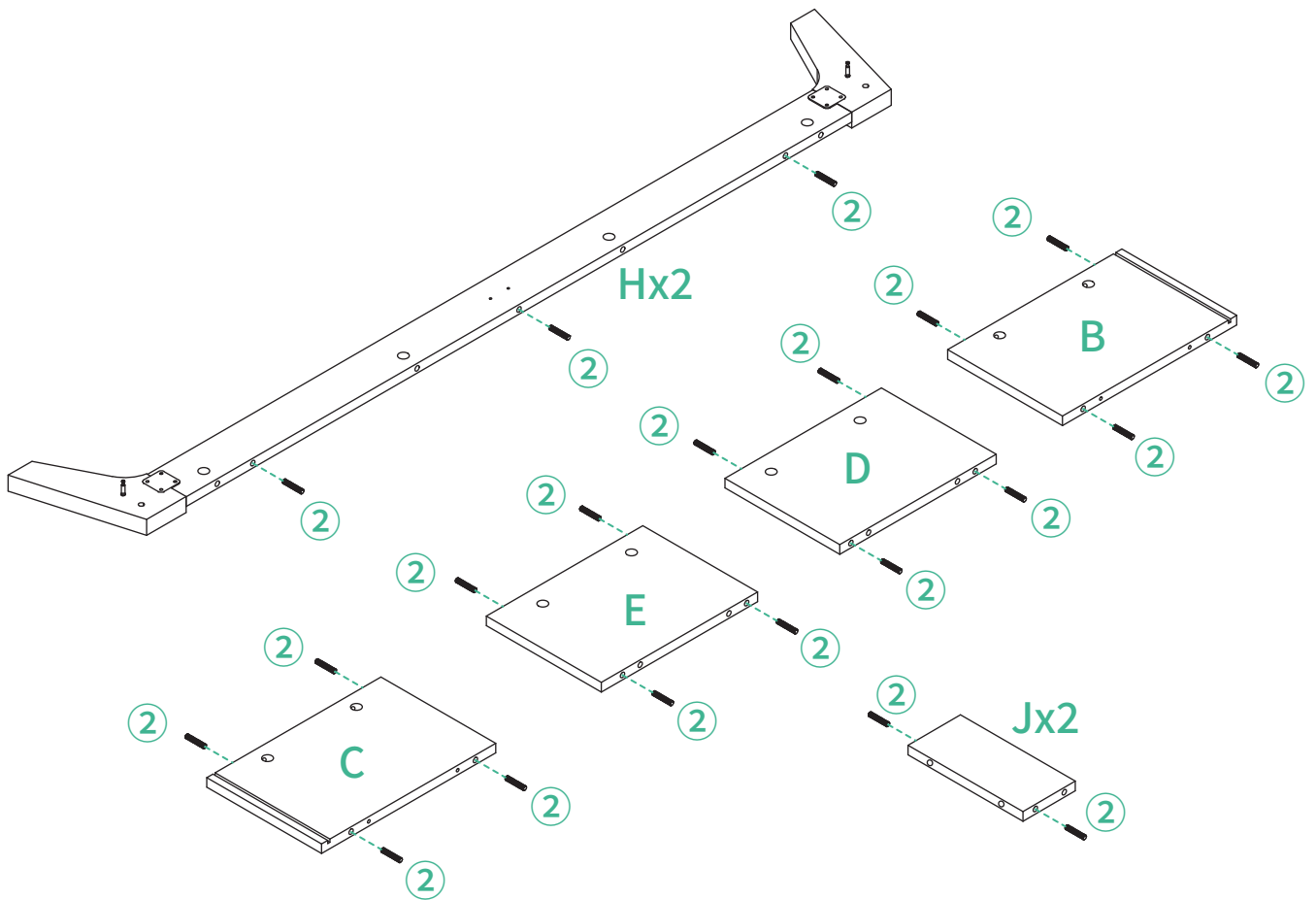

Assembly Instructions

3

L1>L2, Please pay attention to the orientation of components B/D/E/C.

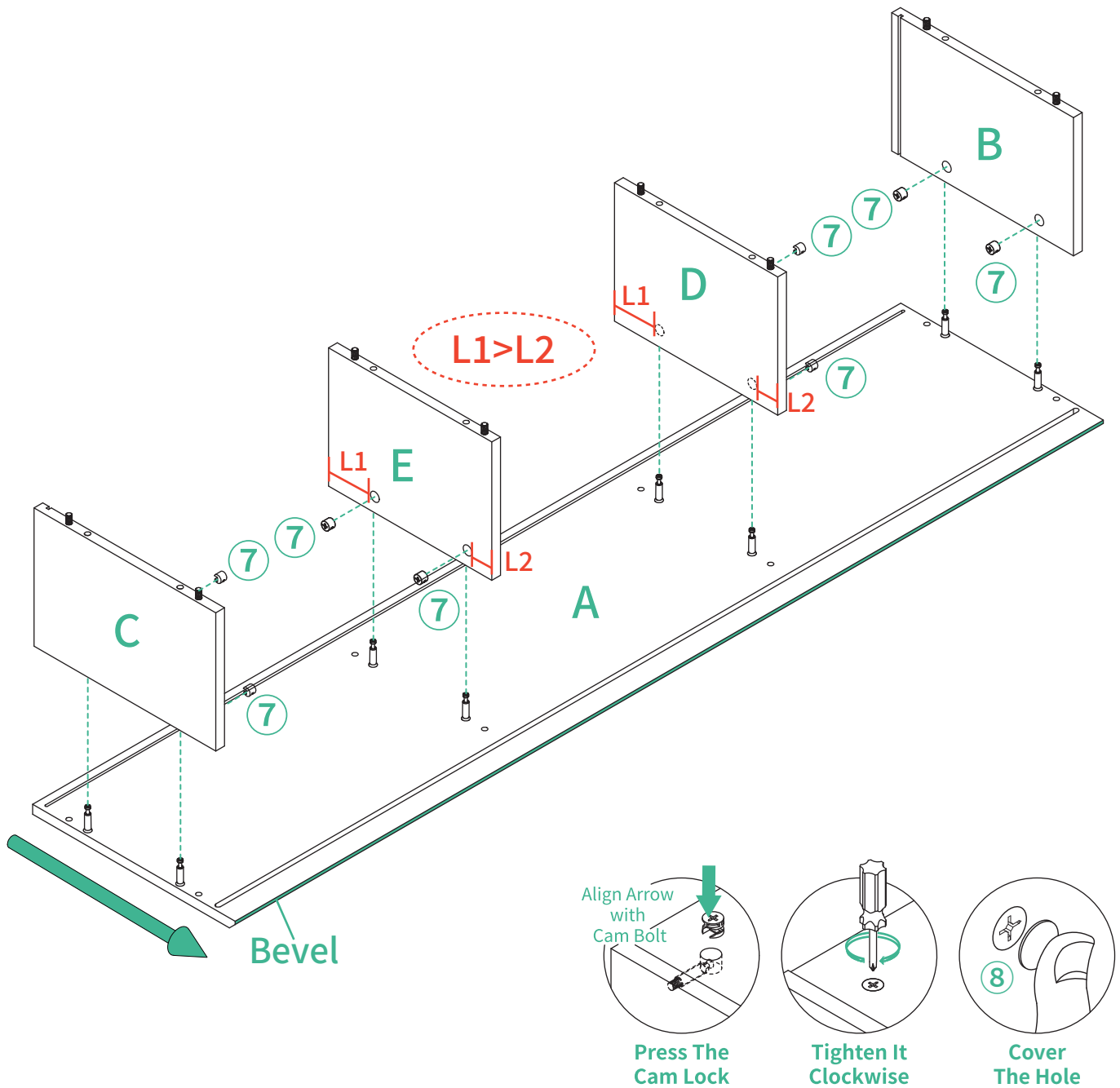

| | | | | | |
|---------|--|---------|--|----------|--|
| 7 x8 | | 8 x8 | | 10 x1 | |
|---------|--|---------|--|----------|--|

| | | | | | | | | | |
|---------|--|---------|--|---------|--|---------|--|---------|--|
| A x1 | | B x1 | | C x1 | | D x1 | | E x1 | |
|---------|--|---------|--|---------|--|---------|--|---------|--|

Assembly Instructions

4

Please insert the F part into the groove.

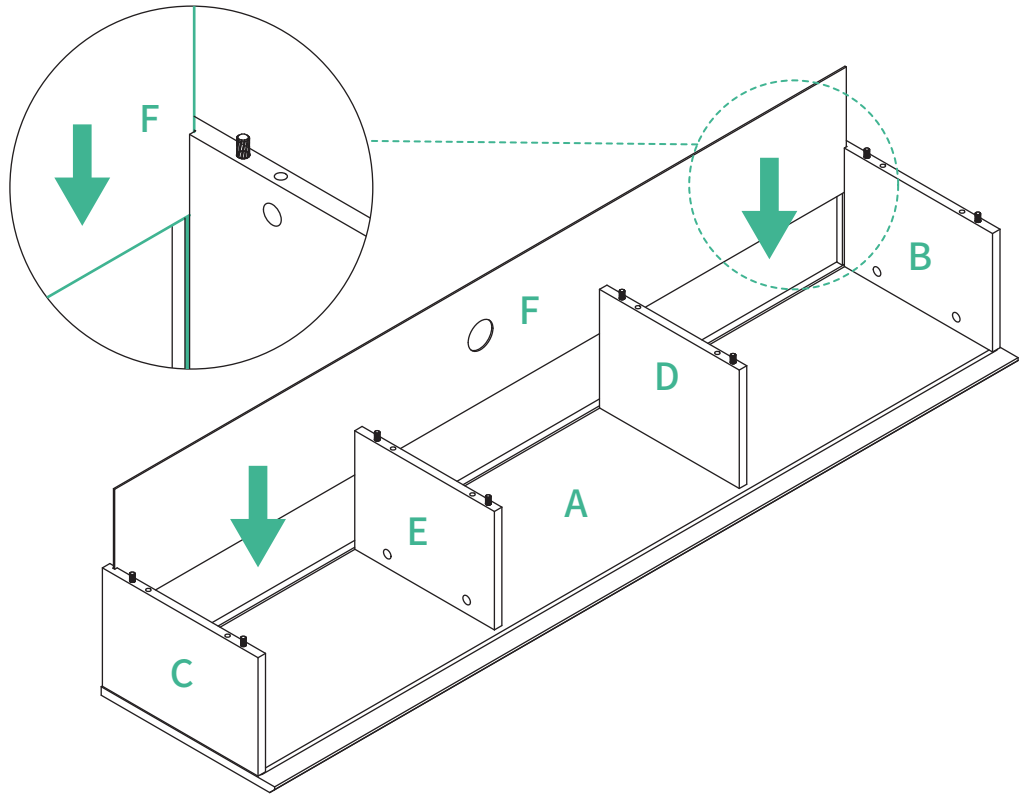
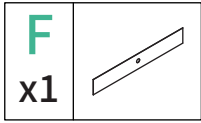



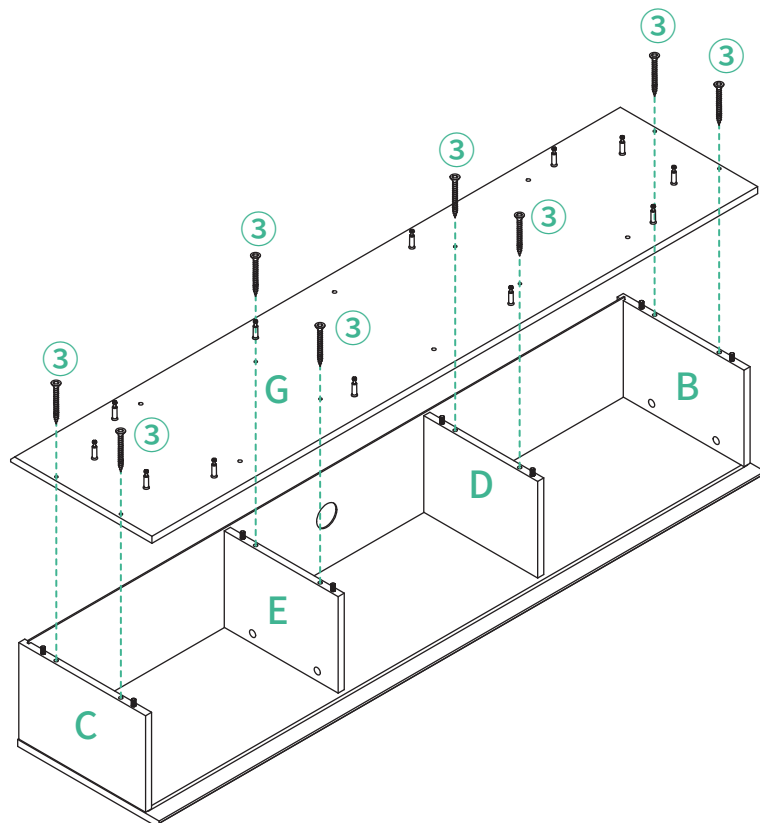
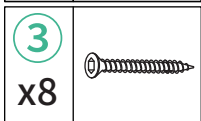
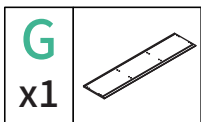



5





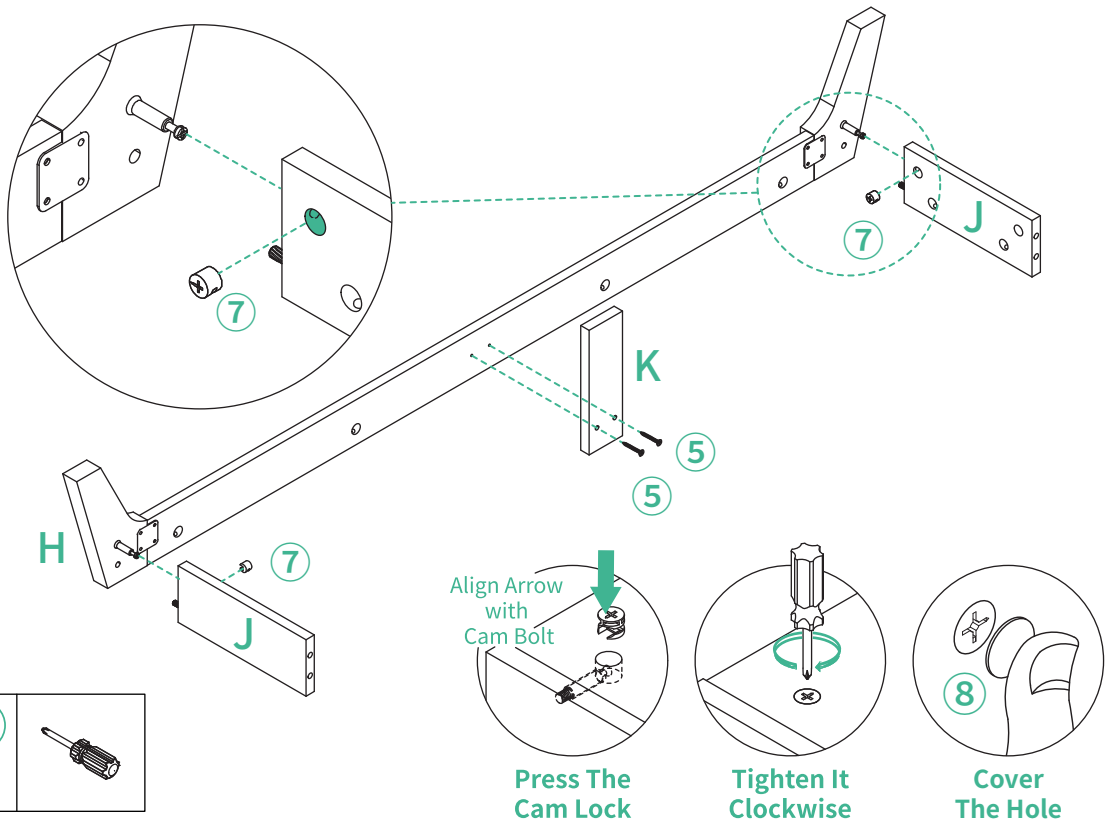

Assembly Instructions

6

| | |
|-----------------|---|
| H x1 |  |
| J x2 |  |
| K x1 |  |
| 5 x2 |  |
| 7 x2 |  |
| 8 x2 |  |
| 10 x1 |  |



7

| | |
|-----------------|---|
| H x1 |  |
| 7 x2 |  |
| 8 x2 |  |
| 10 x1 |  |

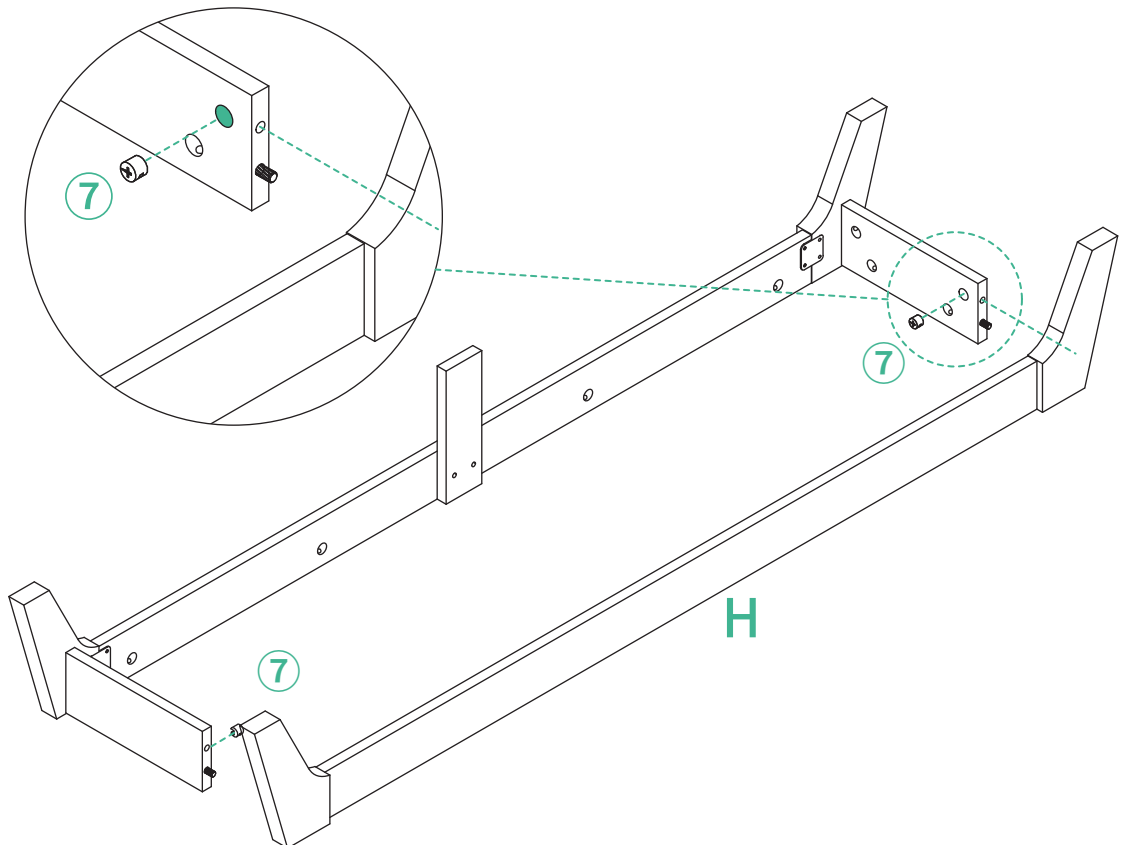

Assembly Instructions

8

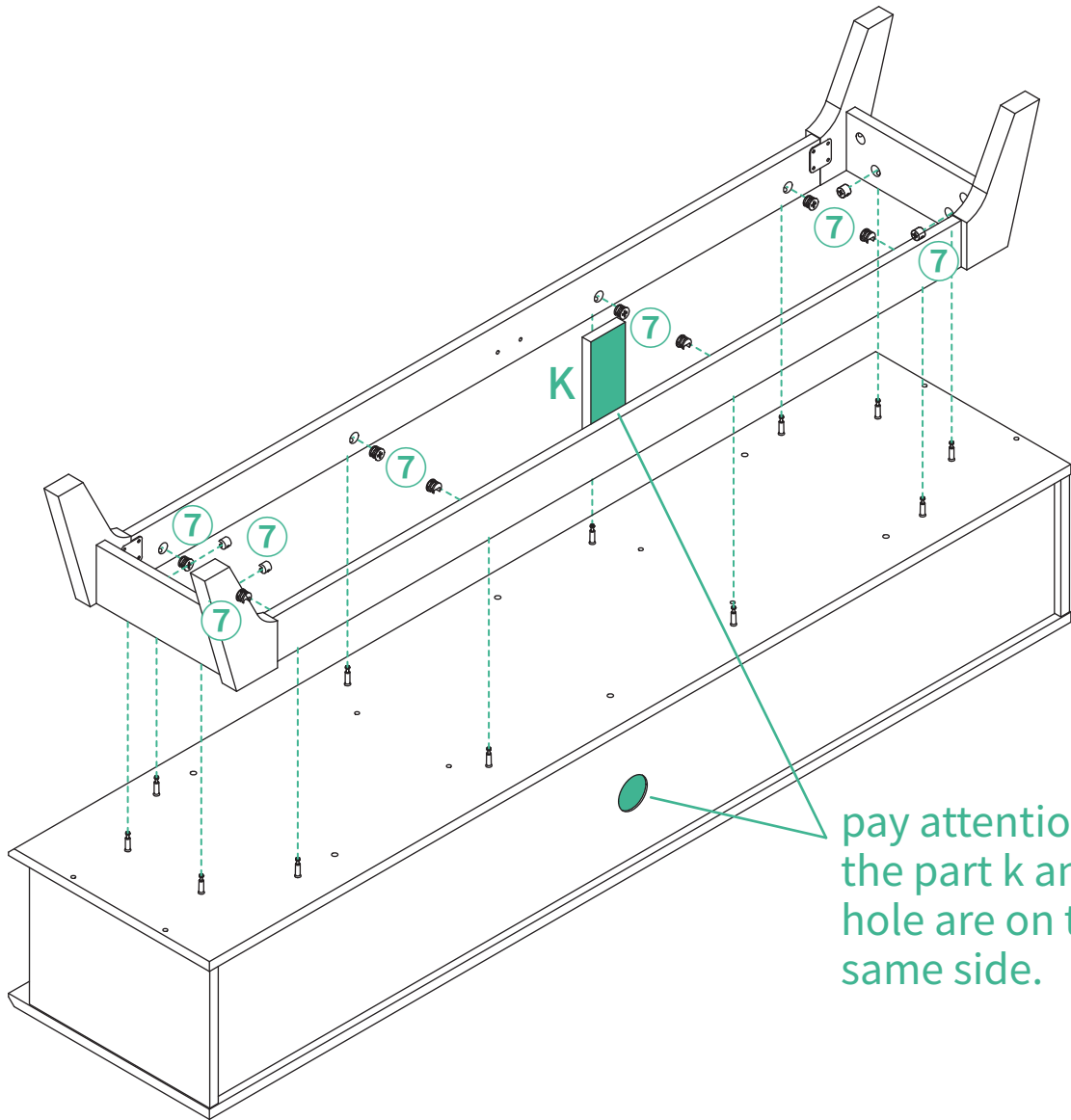

pay attention to the part k and the hole are on the same side.

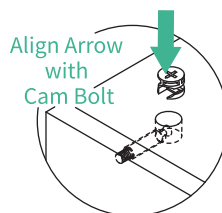



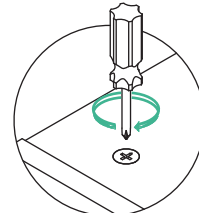



Press The Cam Lock



Tighten It Clockwise



Cover The Hole

| | | | | | |
|--|---|--|---|---|---|
|  x12 |  |  x12 |  |  x1 |  |
|--|---|--|---|---|---|

Assembly Instructions

9

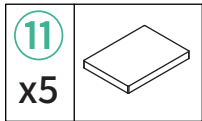
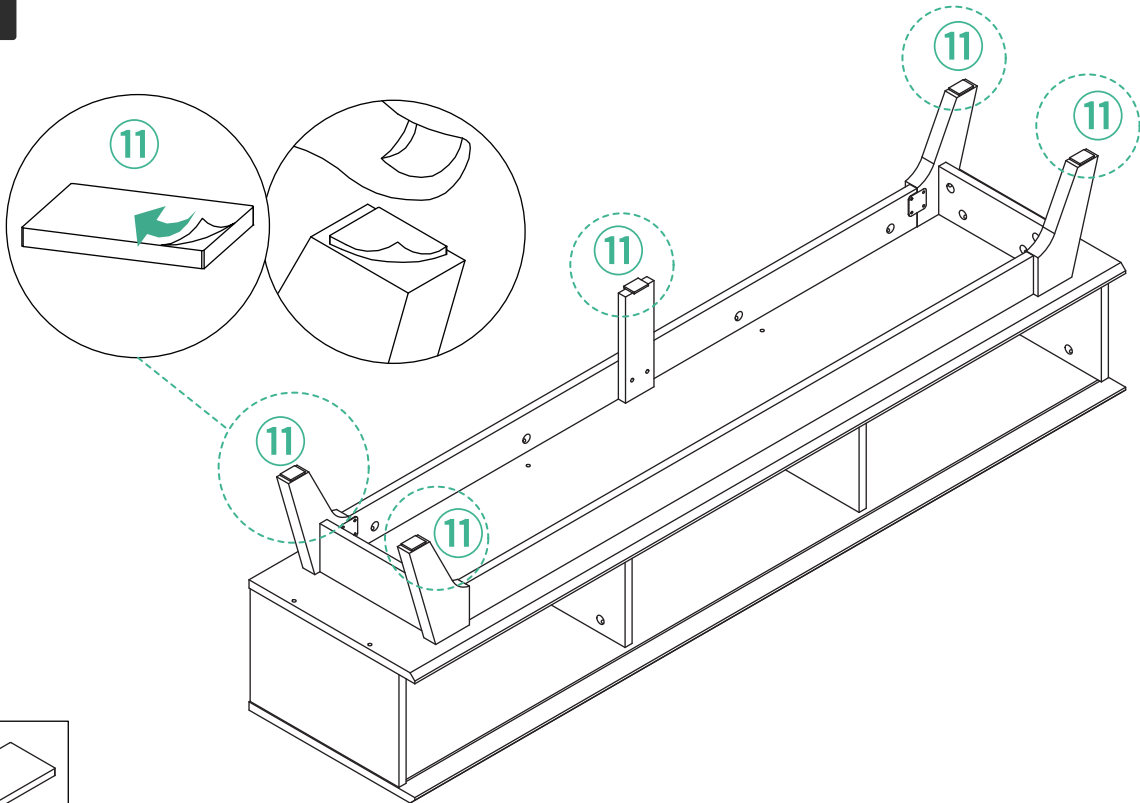

10

As shown in the diagram, when installing part ⑥-a, please ensure that the edge is flush with the edge of the door panel. When installing part ⑥-b, please ensure that the edge is perpendicular to the edge of the panel.

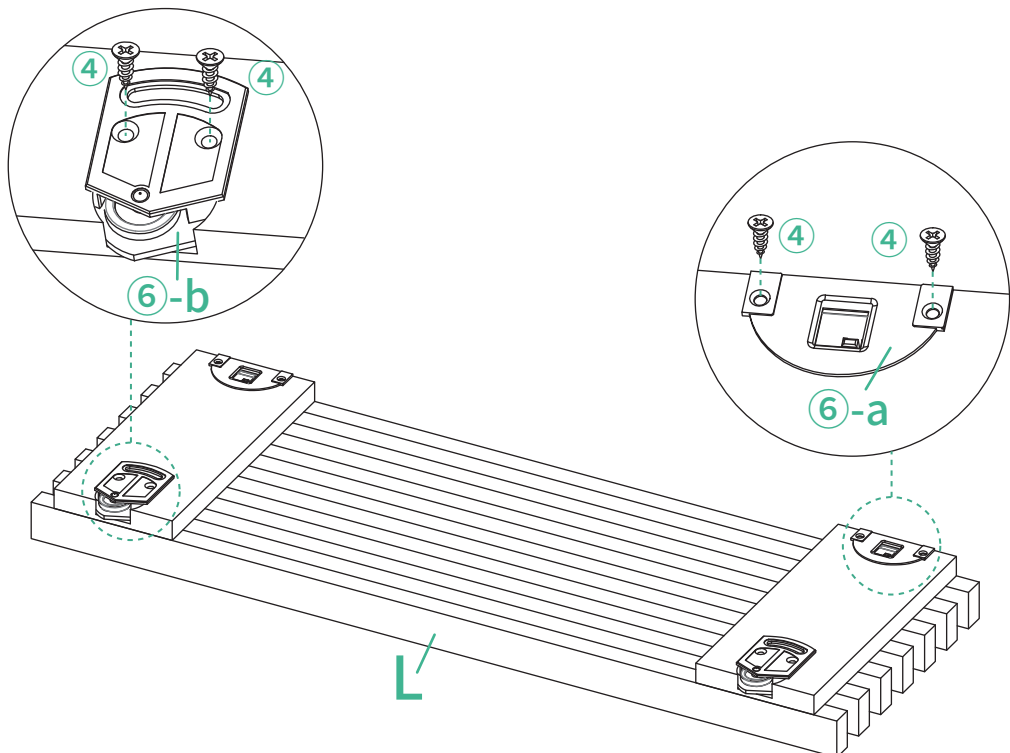
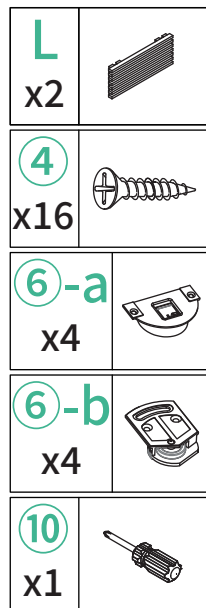

x2

Assembly Instructions

11

Please place L pulley into the slot of the G board. Press and hold the top two buttons simultaneously then push the upper part of the panel into the slot. Finally, check the smoothness of the sliding door.

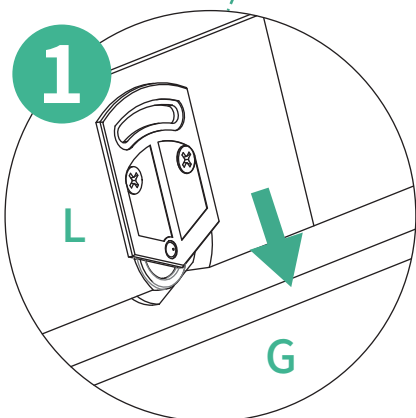
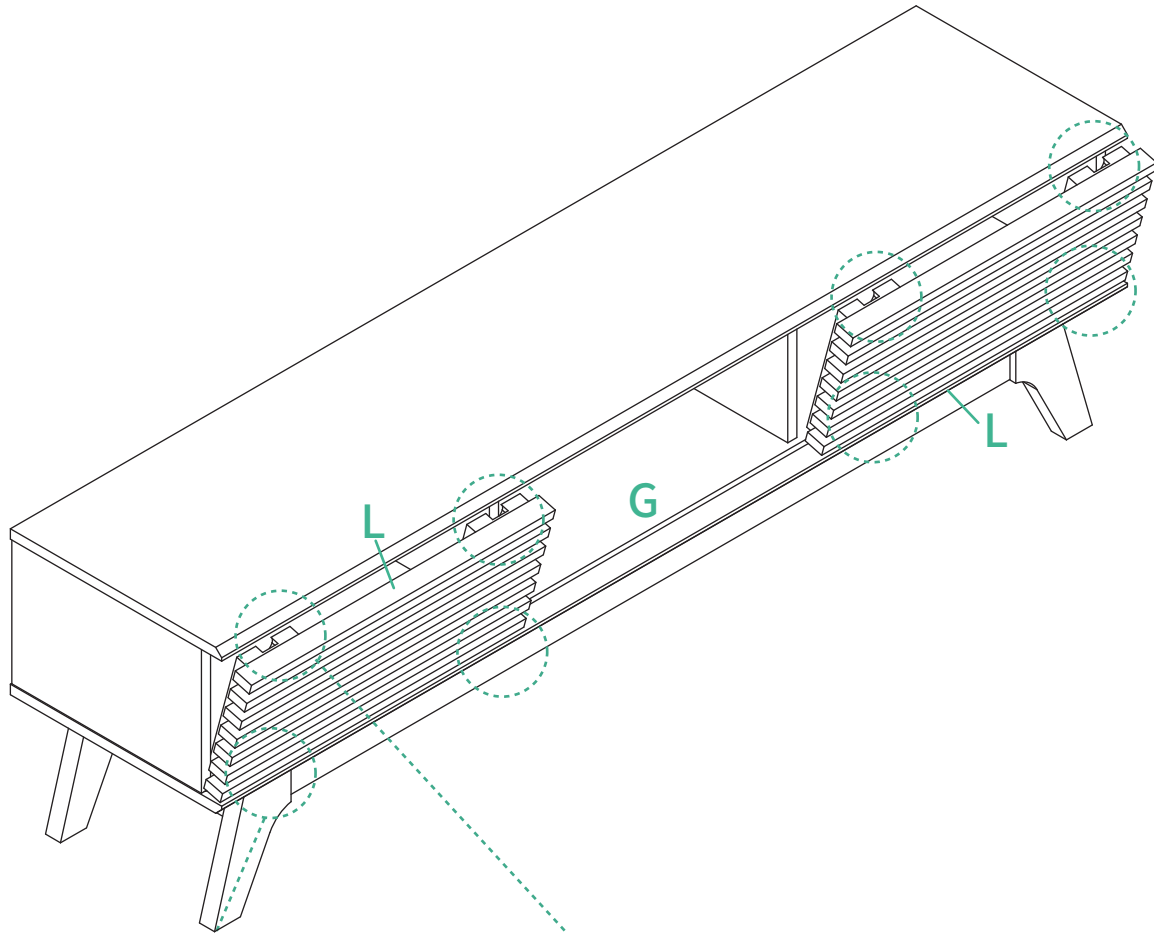

INSERT

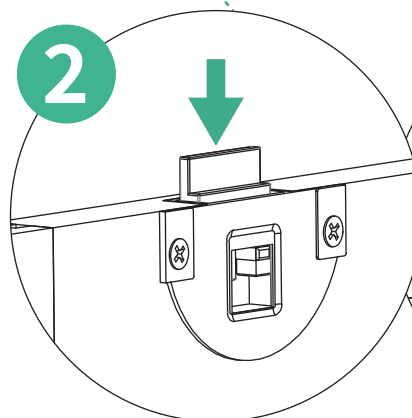

PUSH

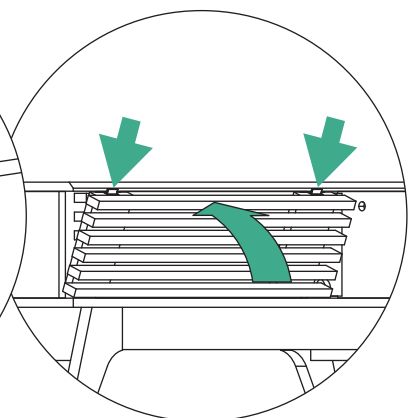

LIFT

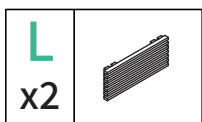



30 DAY Return Policy

If you're not completely satisfied with your purchase, please return the merchandise via our Official Customer Support. Unused merchandise can be refunded or exchanged within 30 days of purchase.



1-Year Warranty

We guarantee your product is free from defects in product material and workmanship for one (1) year starting from the date of purchase during normal use of household conditions. If your appliance fails to operate properly within our warranty period, we will arrange a new one. Replacement is free and all shipping costs are covered.



Quick Response within 24 Hours

If you are still unable to resolve the issue you are experiencing, please contact us immediately via our support email. It doesn't matter if the product has been installed or not, our customer support team will respond within 24 hours and assist you quickly and efficiently. The most efficient way to confirm your problem to us is to attach a video, which illustrates your product issues.

Problems You May Encounter

| PART | PROBLEM | SOLUTION |
|-------------------|---|--|
| Whole Product | Parts are missing, defective or having wrong parts in package. | Contact us via our after-sales phone or email. We will respond within 24 hours. |
| | Having issue(s) while reading the instruction or completing the assembly. | Contact us via our after-sales phone or email. We will respond within 24 hours. |
| | Encountering non-human caused damage during use. | If the product is damaged due to non-human causes, please keep the product and send us photos of it. We will ascertain the cause of the product damage within 48 hours and provide you with a satisfactory solution. |
| Furniture Surface | Surface is broken, scratched or lack of some screw holes. | Contact us via our after-sales phone or email. We will respond within 24 hours. |
| | The screw holes that on the board and the frame don't line up. | <ol style="list-style-type: none"> 1. Tighten the screws only 70% of the way. Do not fully tighten the screws until all parts are aligned. 2. Adjust the board and frame until the holes align, then fully tighten all screws. |
| | Surface is uneven or not tight that has gaps after being assembled. | <ol style="list-style-type: none"> 1. Loosen the screws in the uneven or gap positions; adjust until the surface is flat and tight, and then tighten the screws. 2. If your problem still can't be solved, please feel free to contact us. |
| Structure Frame | Components are bent, broken, chipped, rusted, or damaged. | Contact us via our after-sales phone or email. We will respond within 24 hours. |
| | The furniture is unstable after being assembled. | <ol style="list-style-type: none"> 1. Check if all screws are fully tightened. 2. Read through the manual and check if any parts are installed incorrectly or missing. 3. If the problem persists, please contact us. |
| | Encountering non-human caused damage during use. | If the product is damaged due to non-human causes, please keep the product and send us photos of it. We will ascertain the cause of the product damage within 48 hours and provide you with a satisfactory solution. |

We are committed to providing our customers with premium quality products and convenient customer service.

