

Top Storage Bench Assembly Instructions

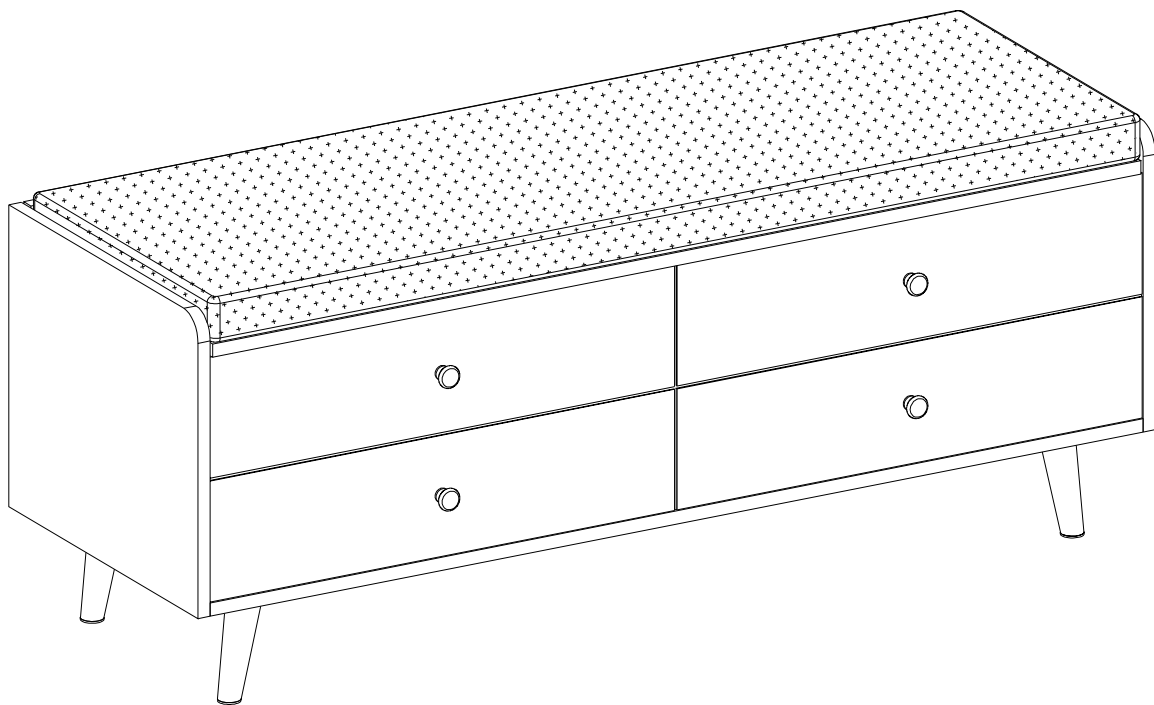

General Assembly Guidelines

- I. Ensure that all parts and hardware are available before beginning assembly.
- II. Follow each step carefully to ensure the proper assembly of this product.
- III. Two people are recommended for ease in the assembly of this product.
- IV. The three main types of hardware used to assemble this product are: wood dowels, screws and bolts.
- V. The provided glue is to secure wood dowels in place. When first inserting dowels, locate the appropriate hole for the dowel, place a small amount of glue in the hole and insert the dowel. Wipe away excess glue immediately.

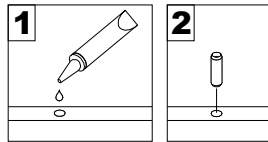

In future assembly steps when dowels are necessary to attach assembly parts together, place a small amount of glue on the end of the dowel before attaching parts together. Wipe away excess glue immediately.

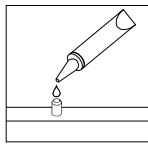

- VI. A Phillips head screwdriver is required for the assembly of this product .

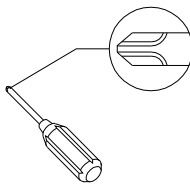



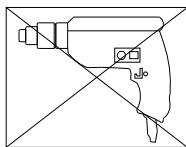



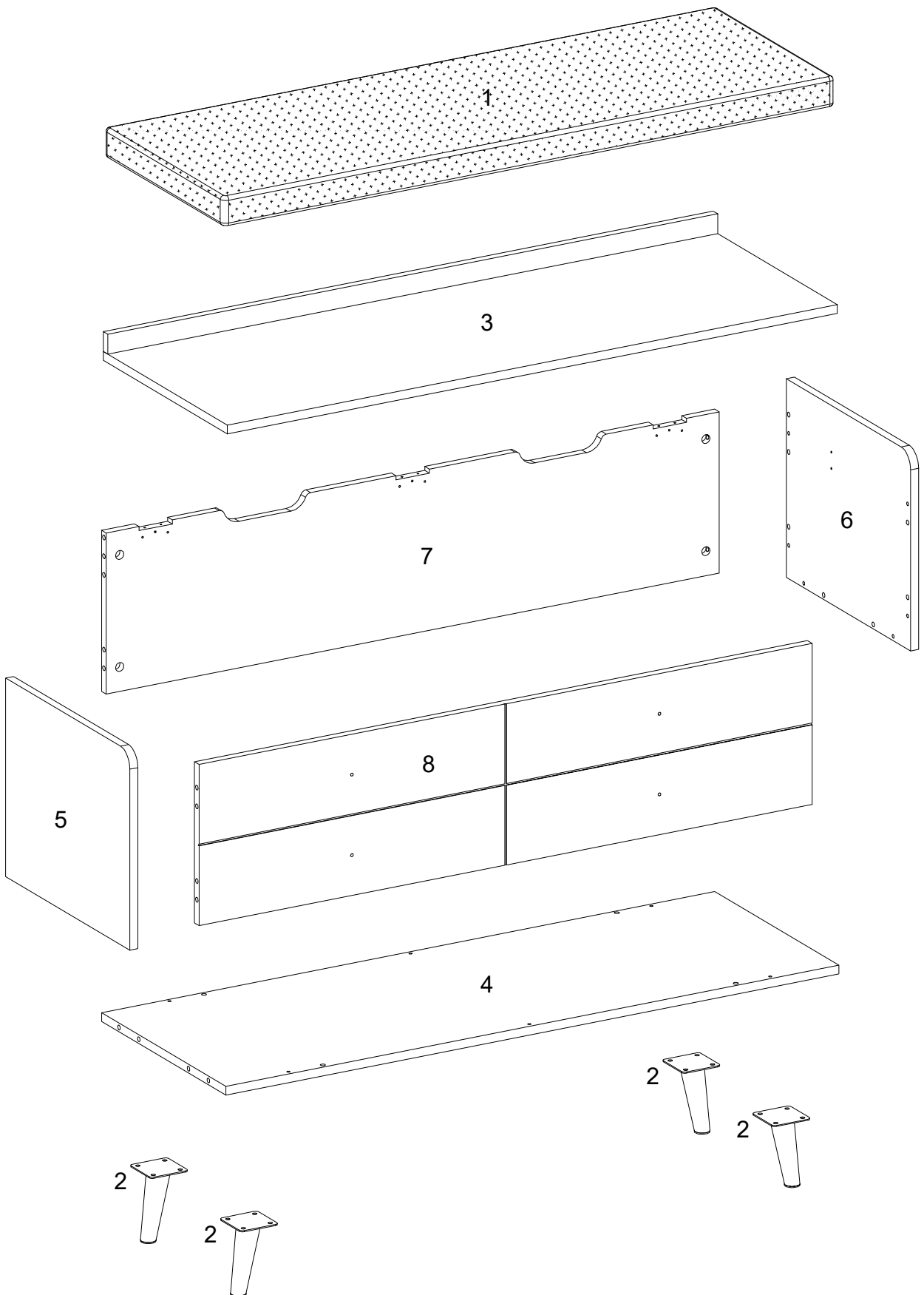







- VII. Power tools should not be used to assemble this product.



Parts List

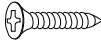

Hardware List

A		Ø8x30mm	Wooden dowel	18	pcs
B		Ø6x35mm	Cam bolt	12	pcs
C		Ø15x11mm	Cam lock	12	pcs
D		Ø30mm	Sticker	12	pcs
E			Handle	4	pcs
F		Ø4x22mm	Handle Bolt	4	pcs
G		Ø4x38mm	Screw	6	pcs
H		Ø6x12mm	Bolt	16	pcs
J		M 4	Hex key	1	pc
K			Hinge	3	pcs
L		Ø4x12mm	Screw	32	pcs
M			Hinge	1	pc
N			Hinge	1	pc
P			Glue tube	1	pc

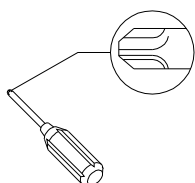

Philips head screwdriver required for assembly
(not included)

*The hardware quantities listed above are required for proper assembly.
Some extra hardware may also have been included.*

Step 1

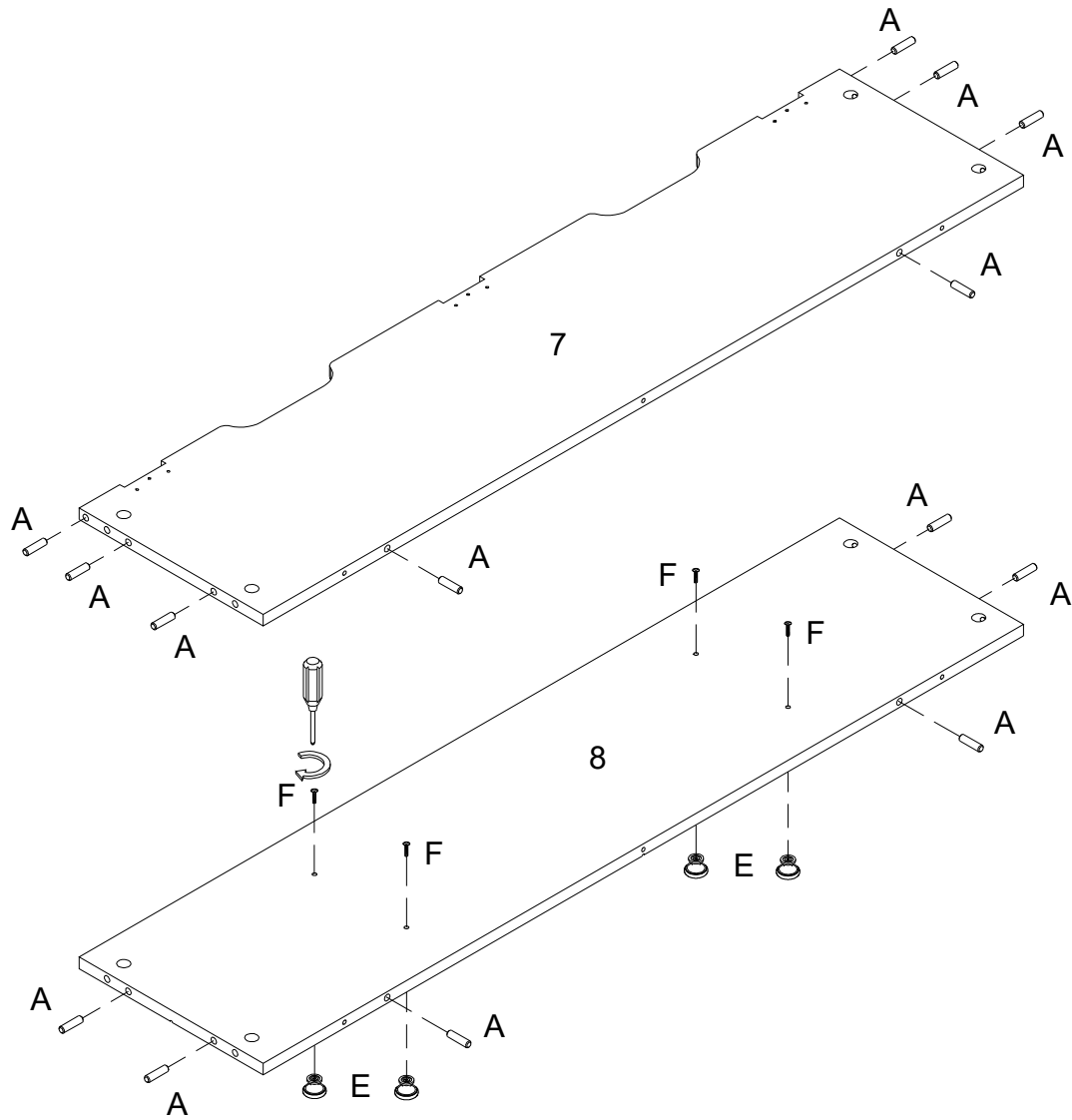

Insert wooden dowel (A) into parts (7,8), then using Handle bolt (F) secure Handle (E) into part (8) with Philips head Screwdriver as per diagram.

Step 2

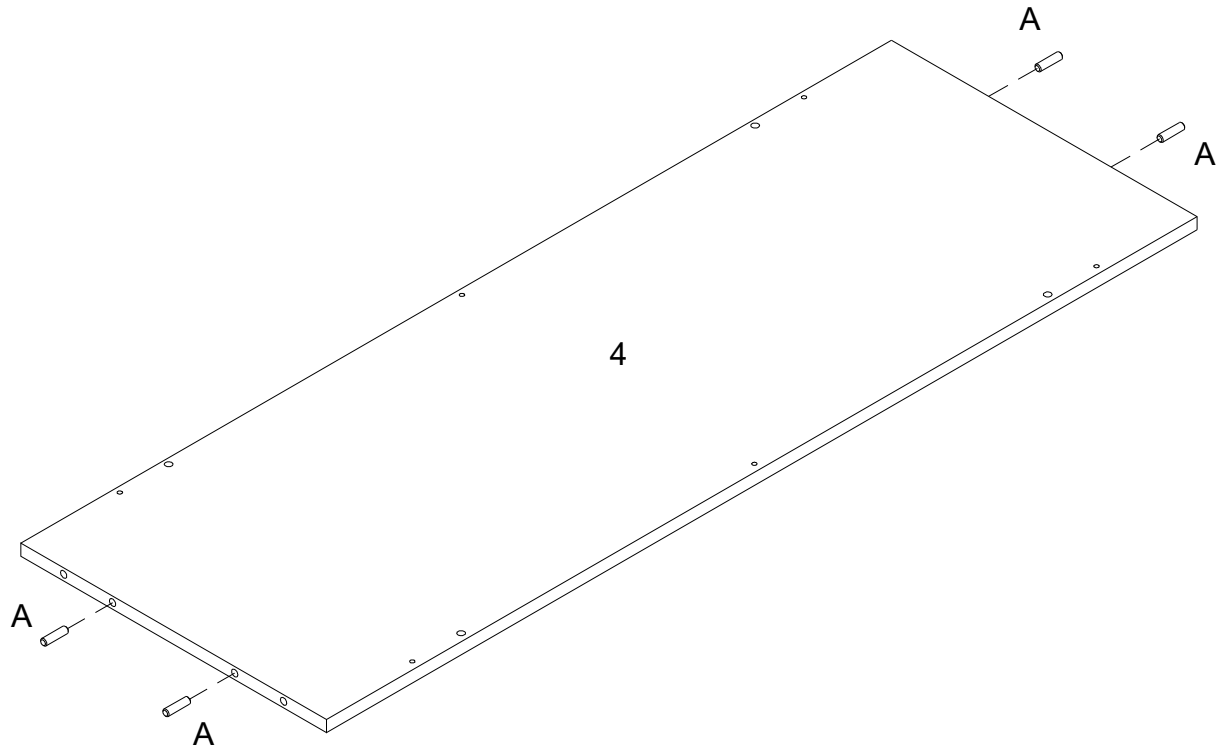

Insert wooden dowel (A) into part (4) as per diagram.

Step 3

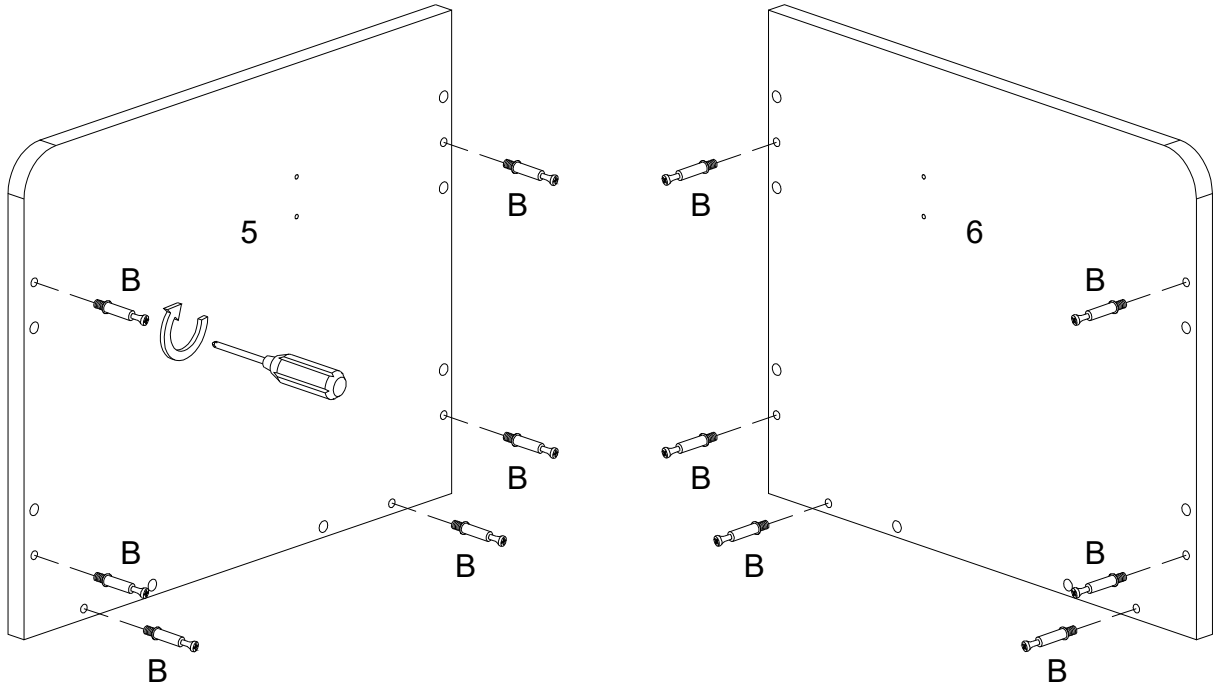

Secure Cam bolt (B) into parts (5,6) with Philips head screwdriver as per diagram.

Step 4

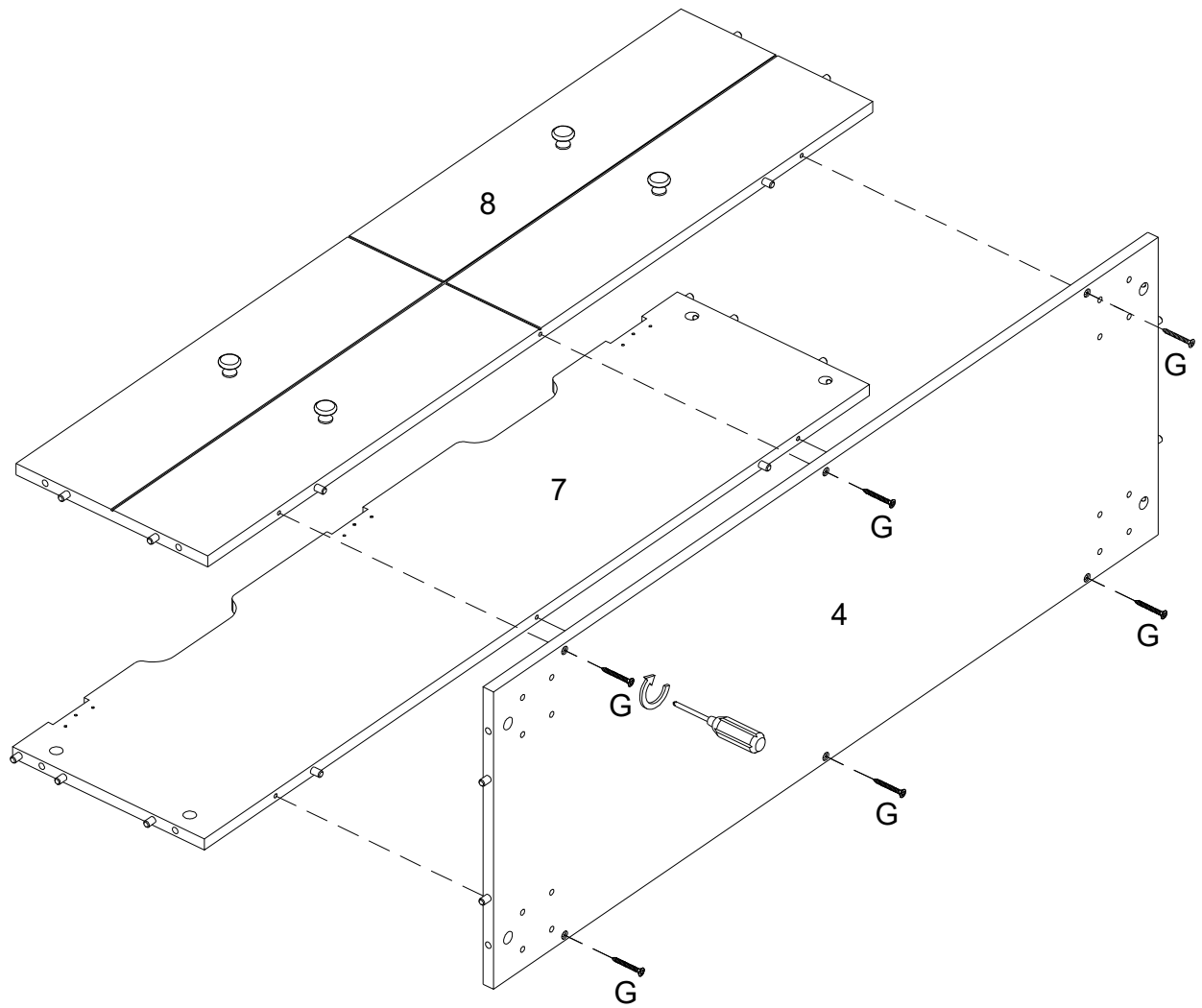

Using screw (G) attach part (4) into parts (7,8) with Philips head screwdriver as per diagram.

Step 5

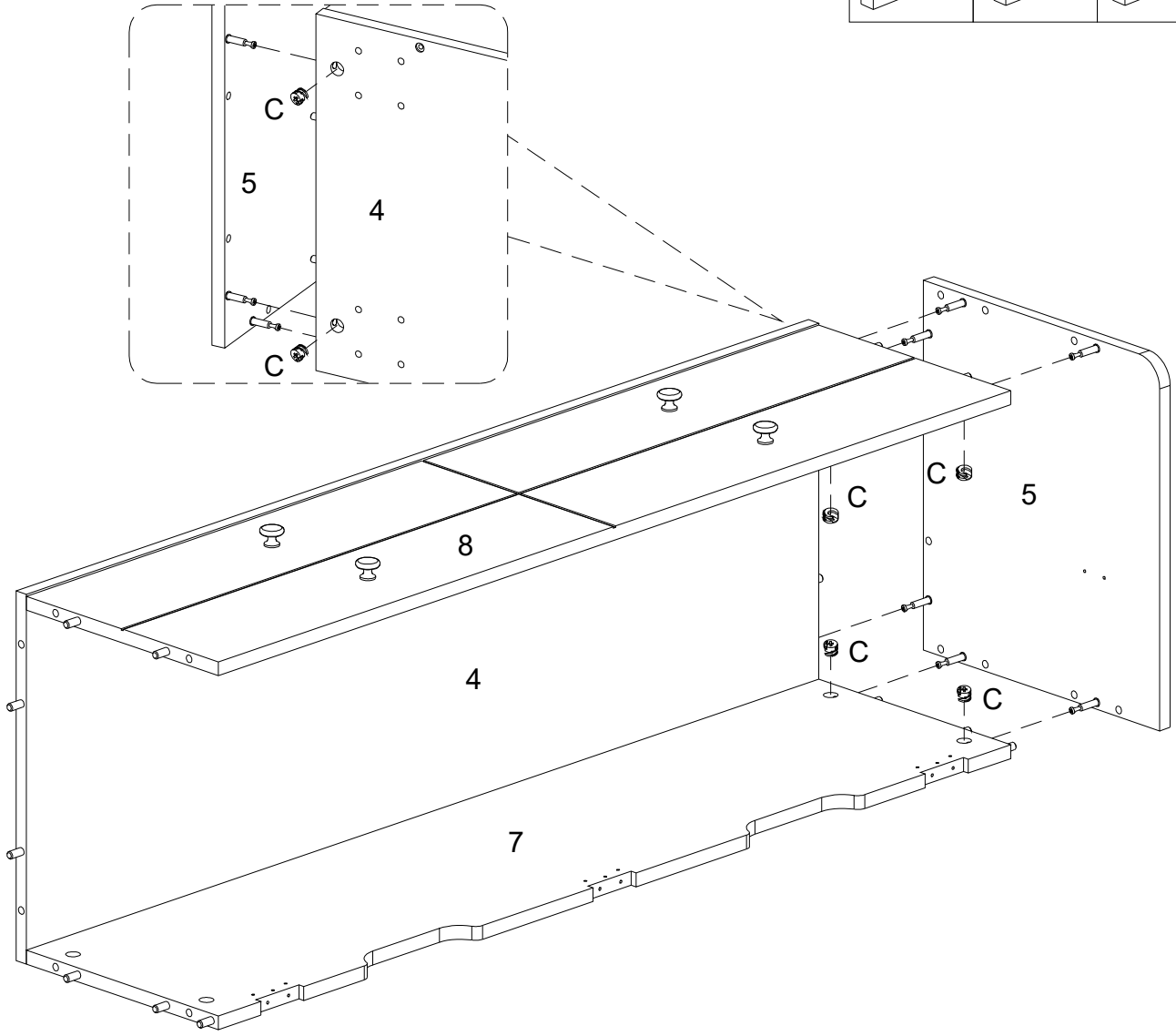
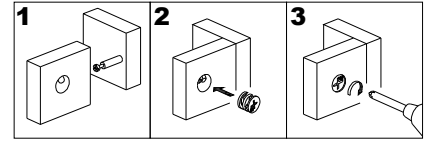

Using cam lock(C) secure part (5) to parts (4,7,8) with Philips head screwdriver as per diagram.

Step 6

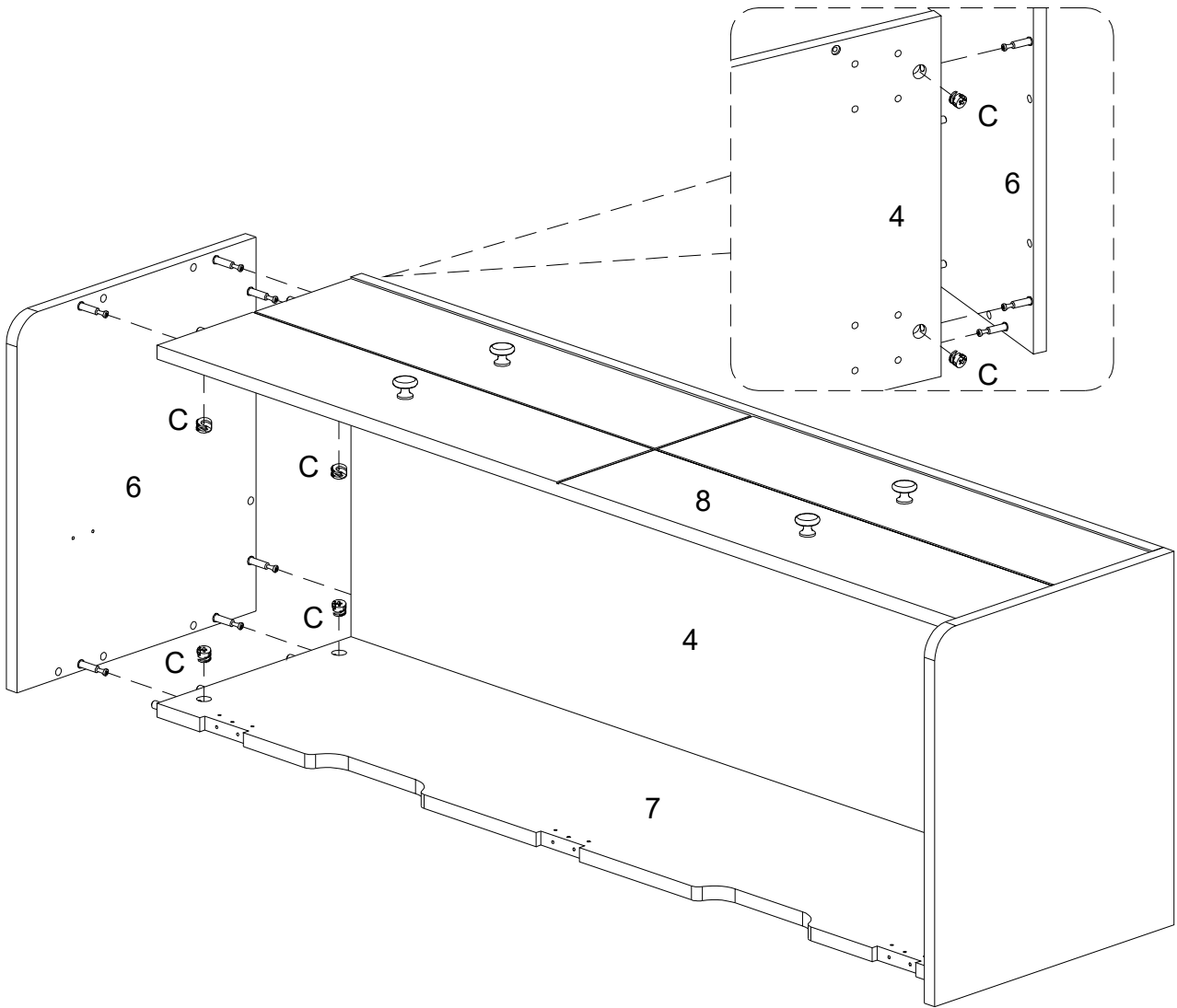
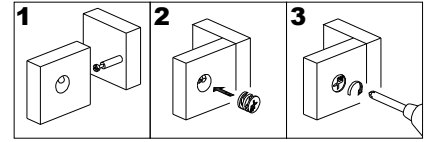

Repeat the last step as per diagram.

Step 7

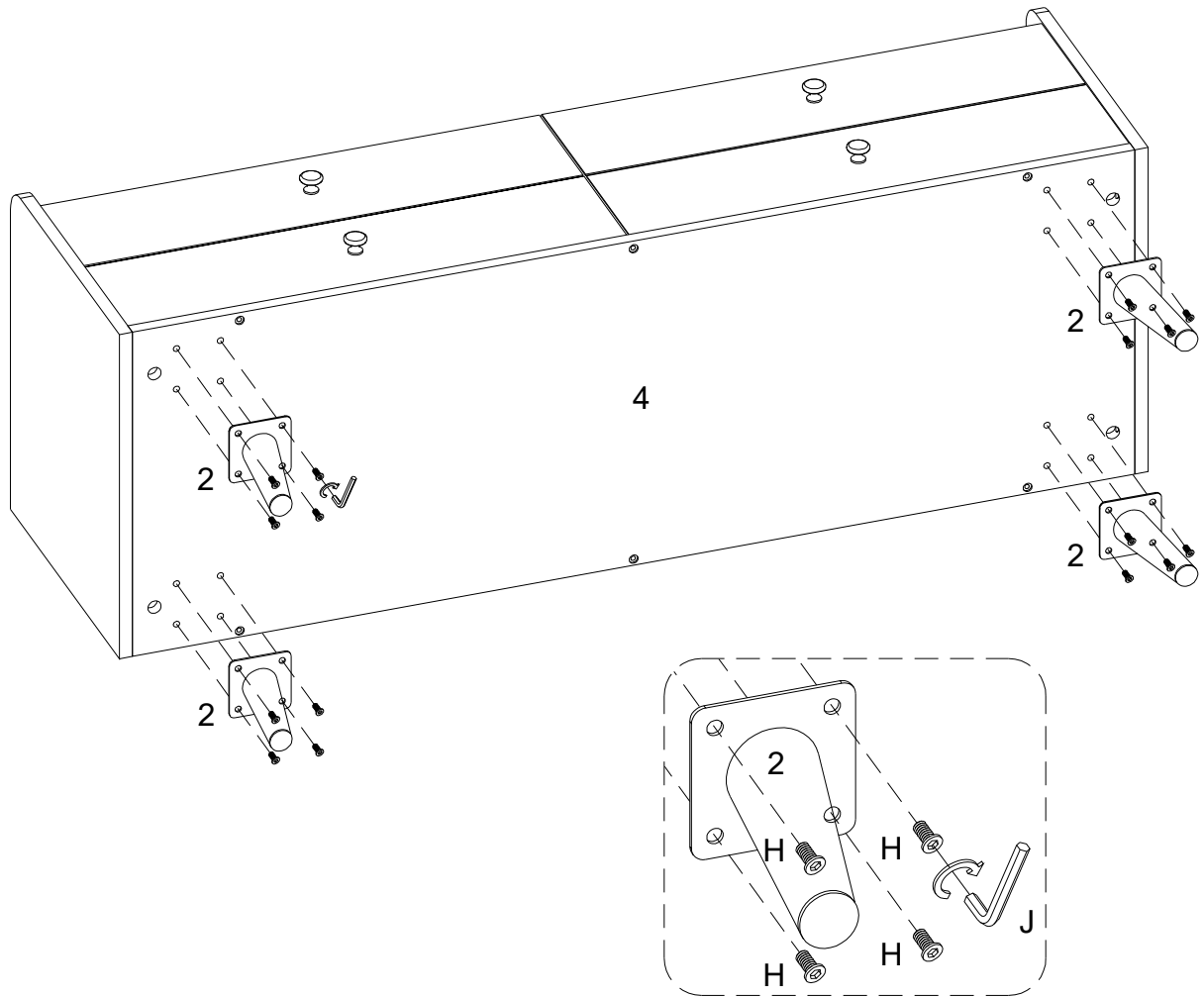

Using bolt (H) attach part (2) to part (4) with Hex key (J) as per diagram.

Step 8

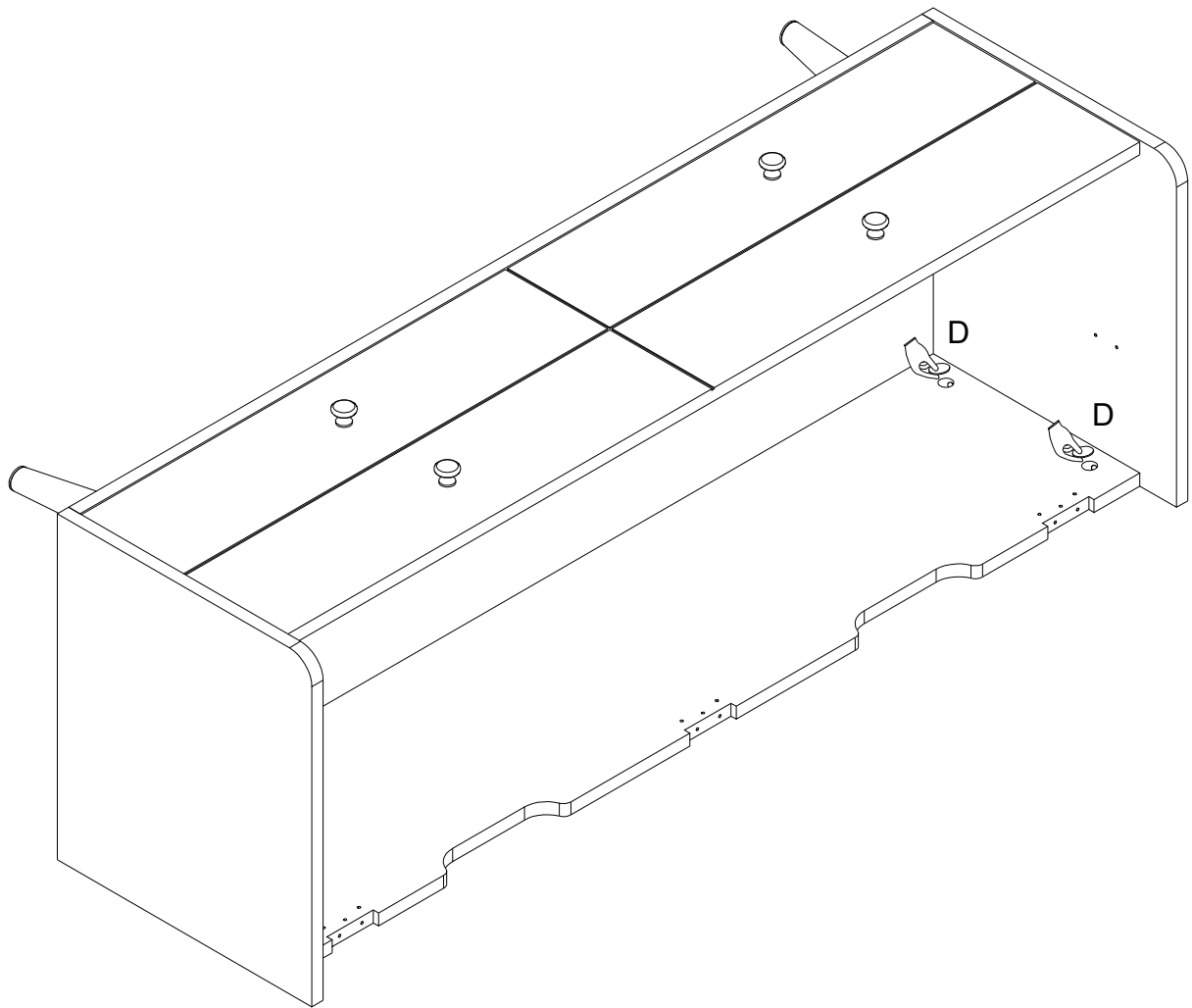

Place sticker (D) cover the holes as per diagram .

Step 9

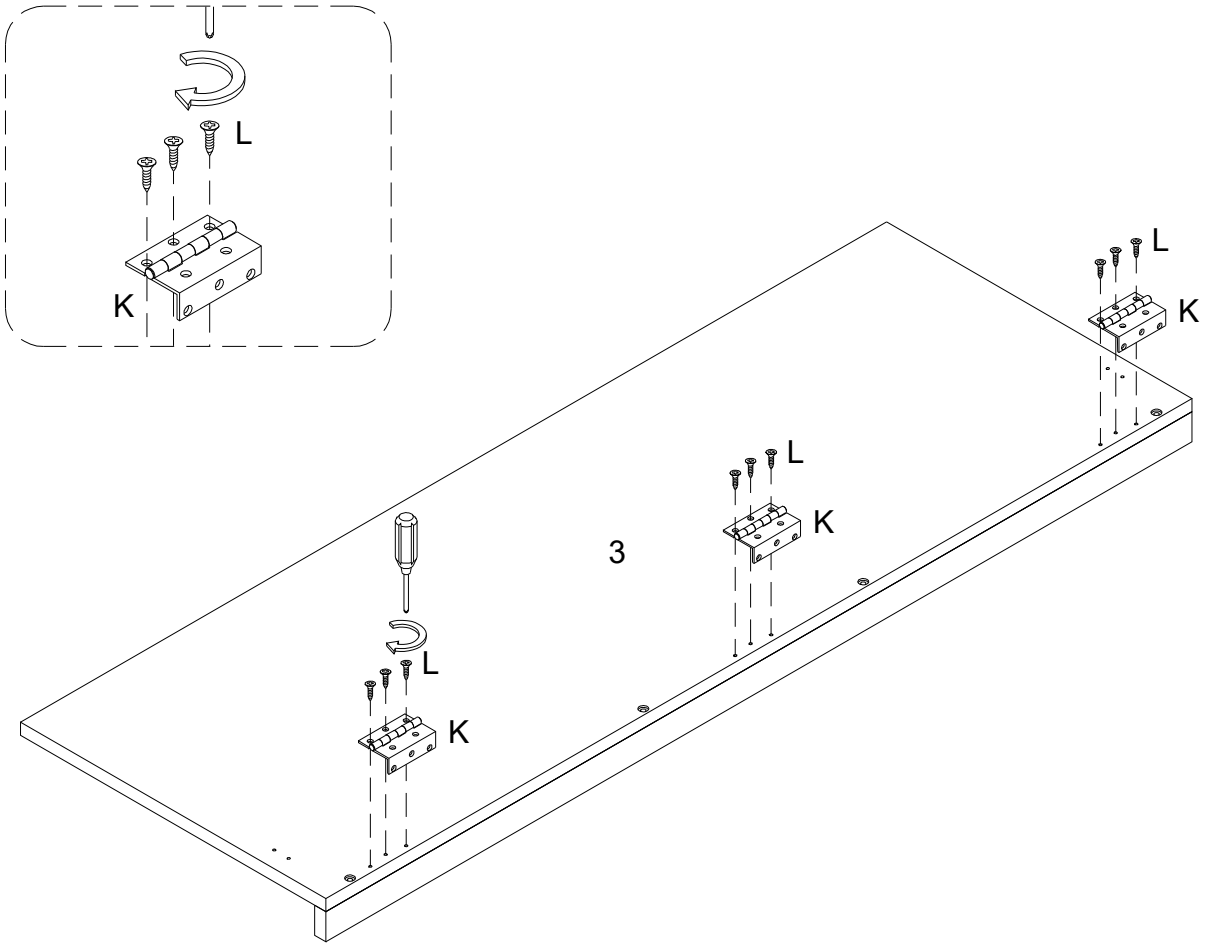

Using Screw (L) attach Hinge (K) to part (3) with Philips head screwdriver as per diagram.

Step 10

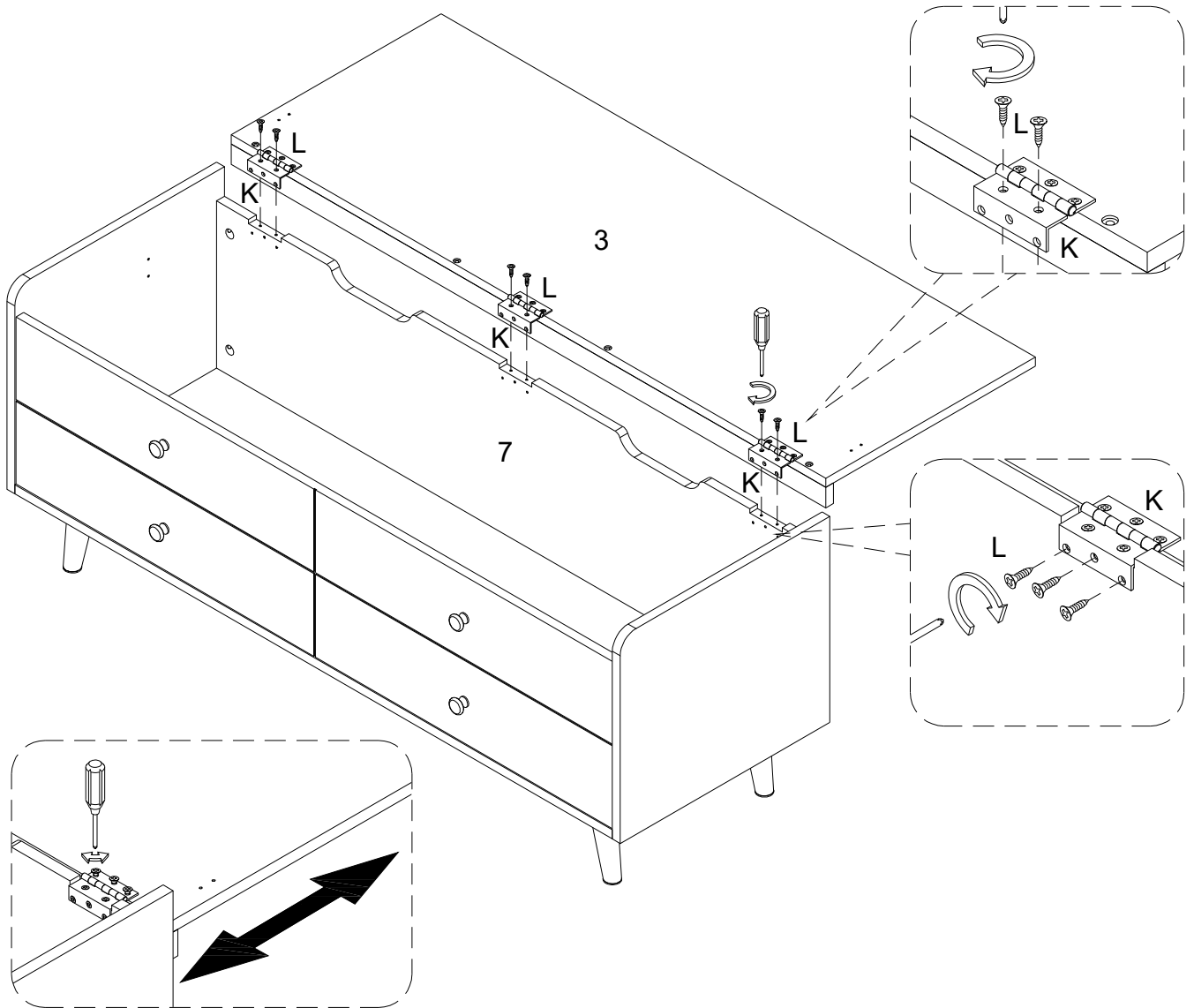

Using Screw (L) attach Hinge (K) to part (7) with Philips head screwdriver as per diagram.

Step 11

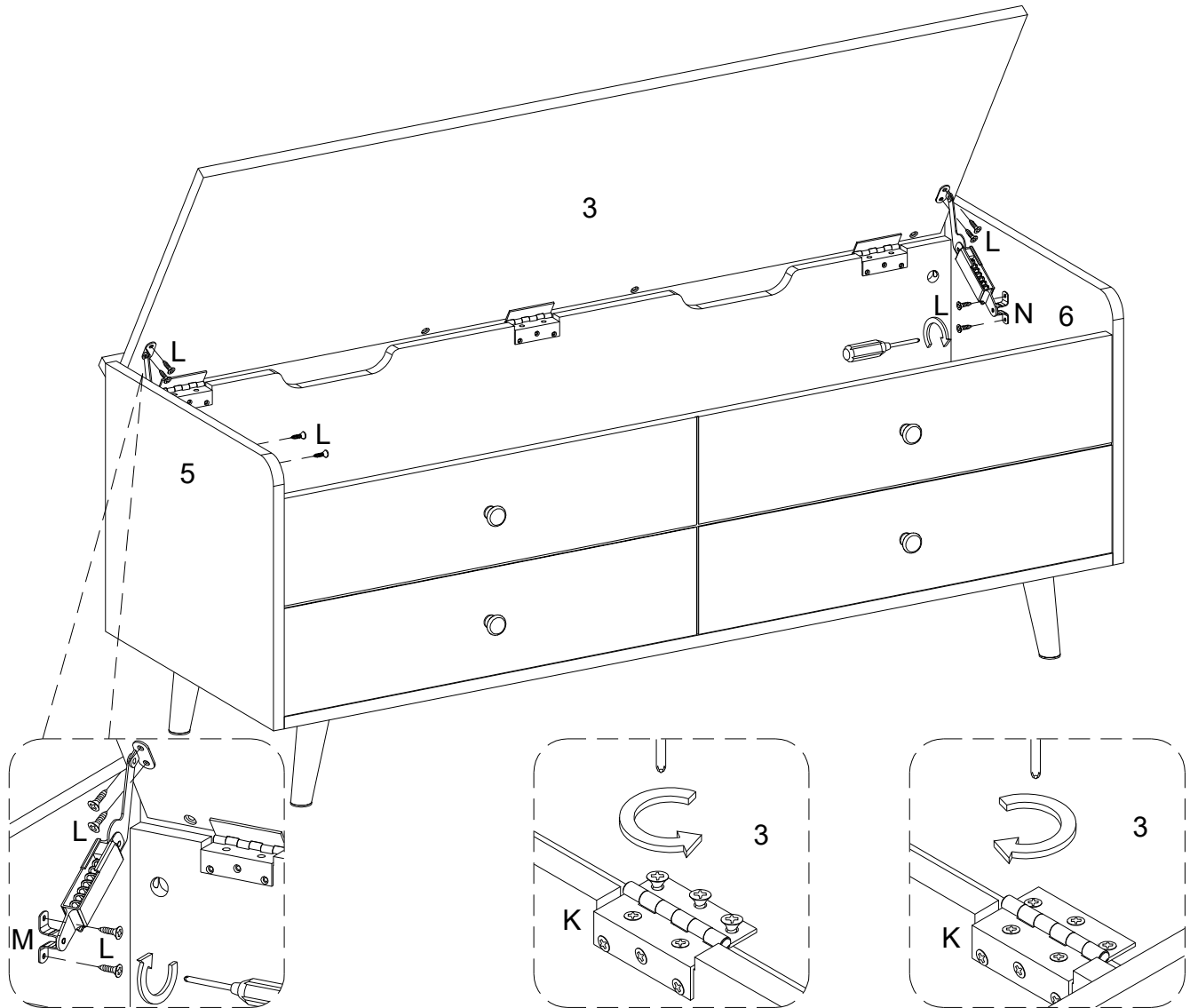

Using screw (L) attach hinge (M,N) to parts (3,5,6) with Philips head screwdriver as per diagram.
If the gap between the part (3) and side panels need to be adjusted, please first loosen the screws fixing hinge (K) to the part (3). Finally adjust one side of the side panel up or down, and then lock the hinge (M,N).

Step 12

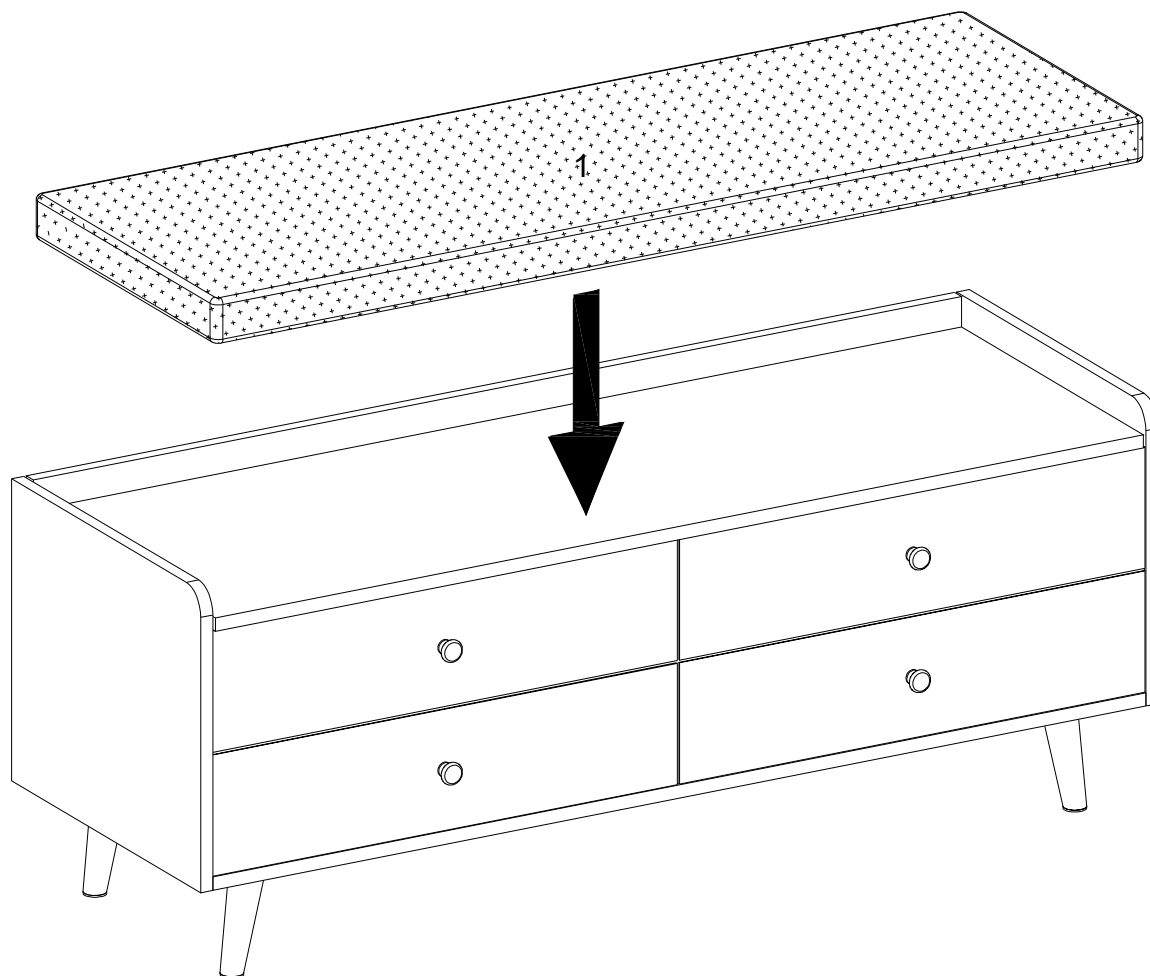

Put part (1) as per diagram.

Step 13

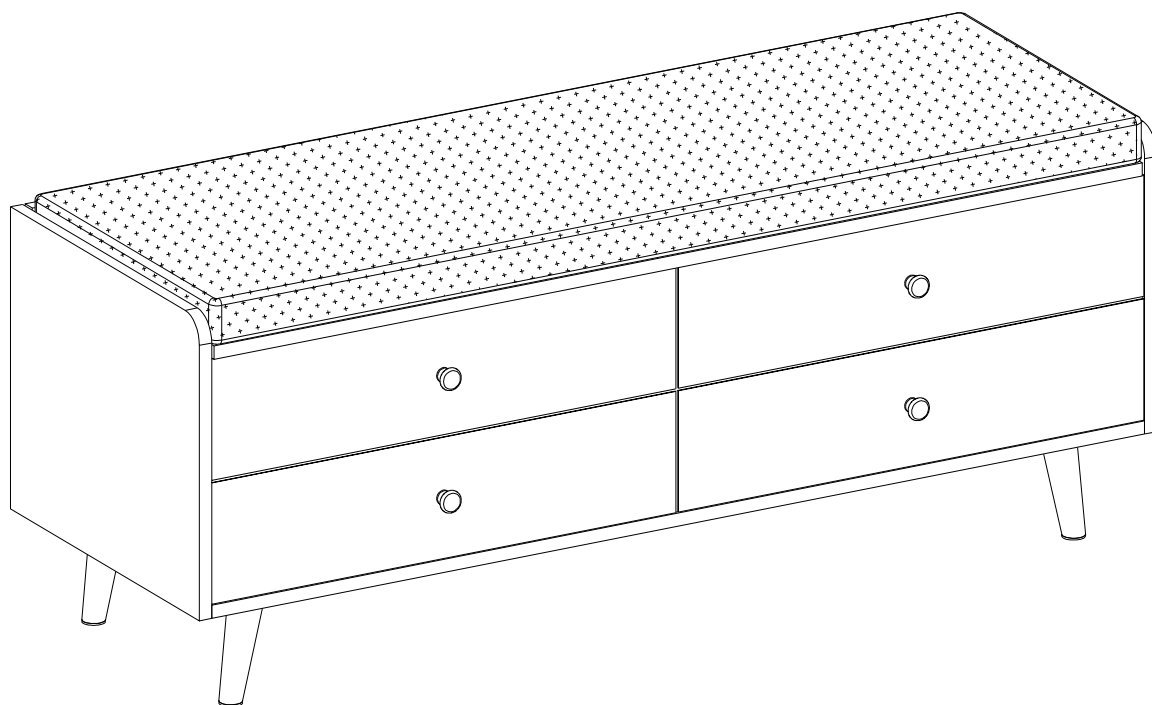

Final Assembly