

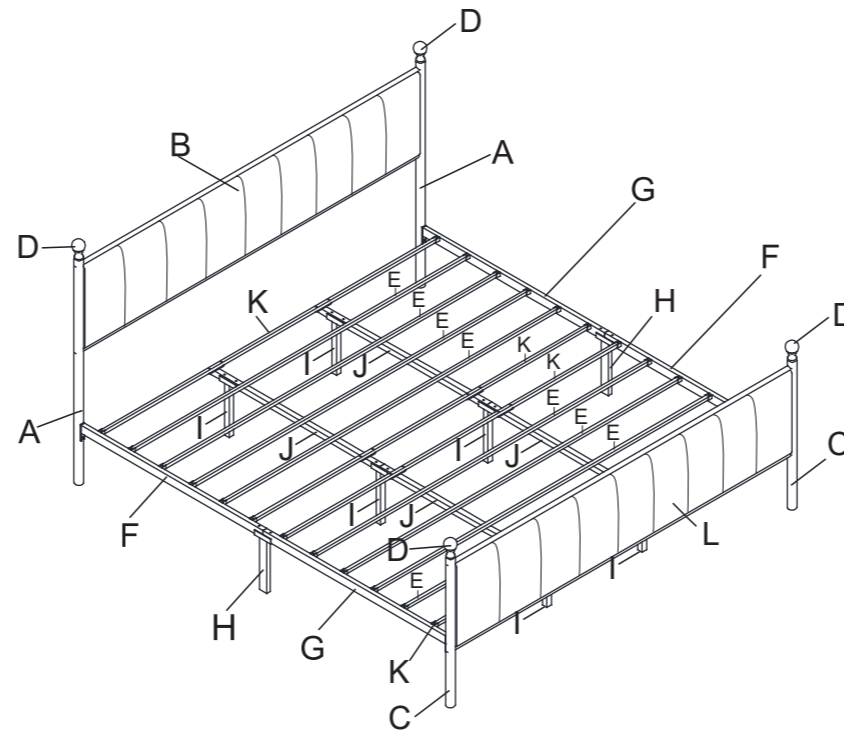

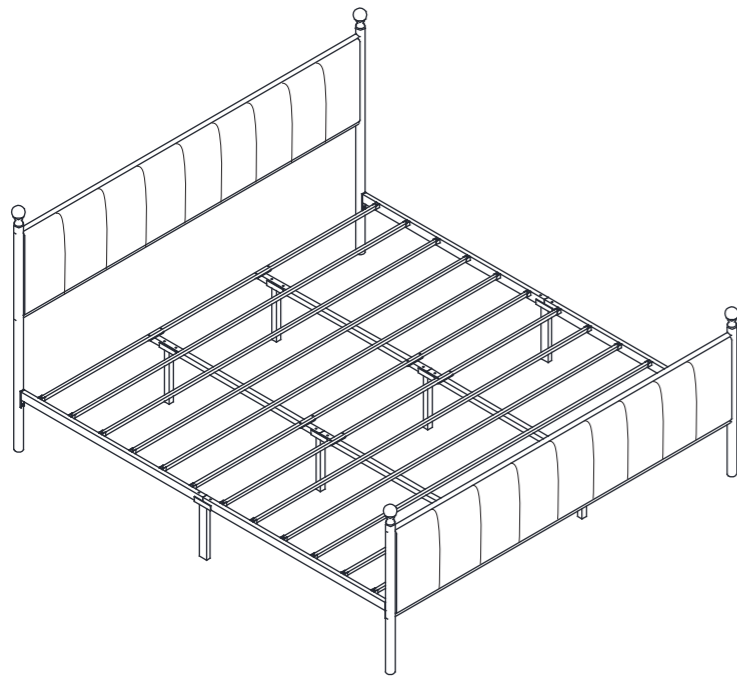

Assembly Instructions



Dear Customers,

Thank you for purchasing our product. Please read this instruction manual carefully after receiving this product. It will help you assemble this product quickly, safely and correctly. You can keep this manual for future reference.

Notice: Do not tighten the screws too tightly at the beginning of the assembly. After each hole position is matched well, with gently force to screw, if there is no problem, then tighten all the screws.

A	2PCS	B	1PC	C	2PCS
D	4PCS	E	8PCS	F	2PCS
G	2PCS	H	2PCS	I	6PCS
J	4PCS	K	4PCS	L	1PC
M	20PCS	N	1PC	O	40PCS
 M8x50mm		 		 M6x20mm	

1

P	12PCS		
 M8x35mm			

2

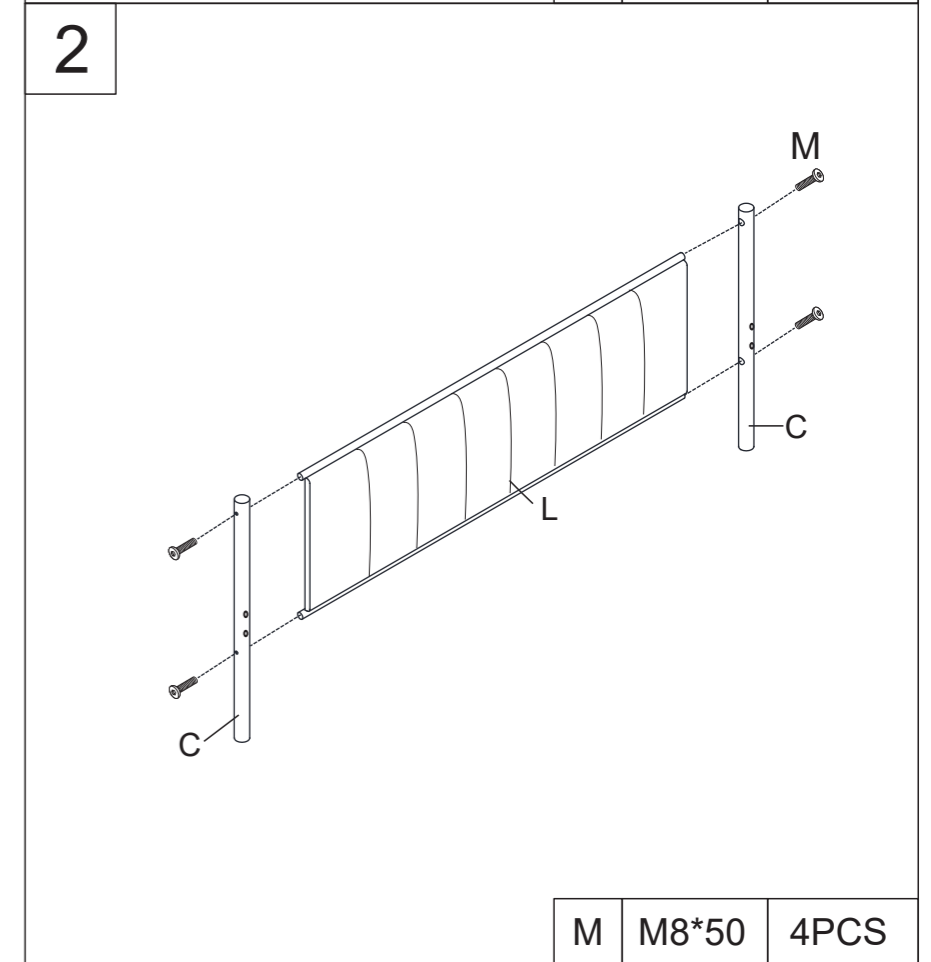
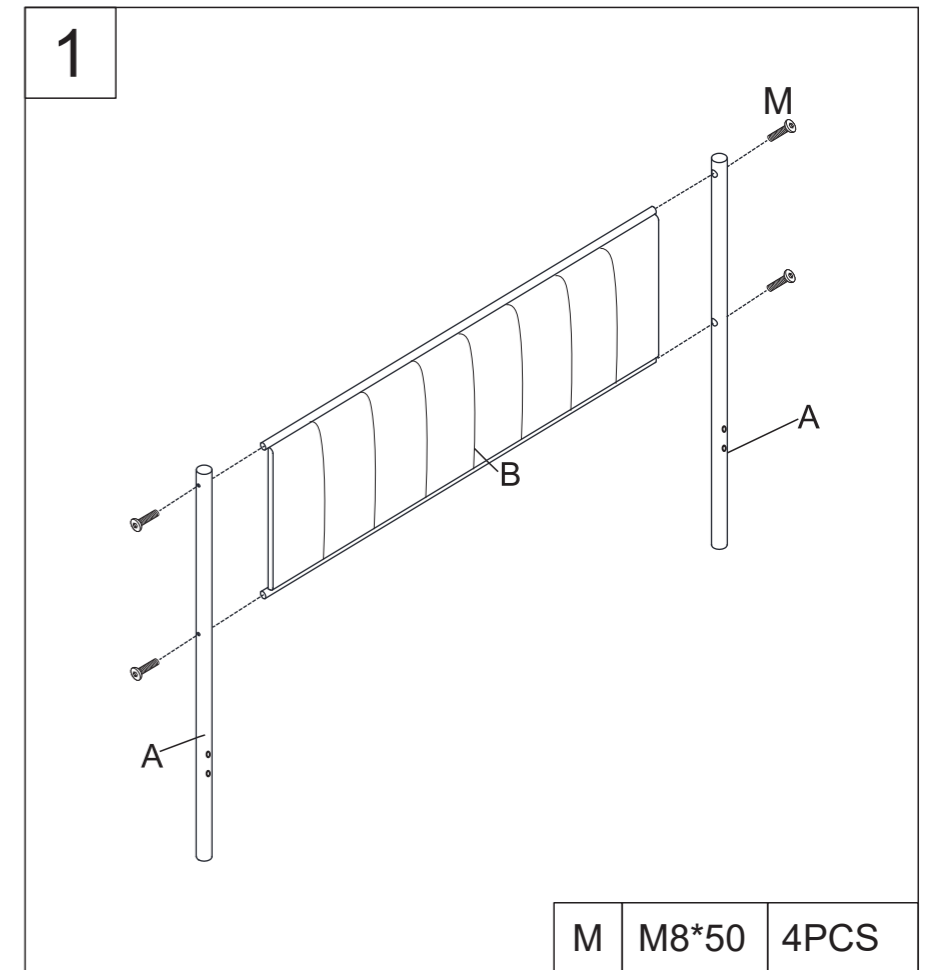

3

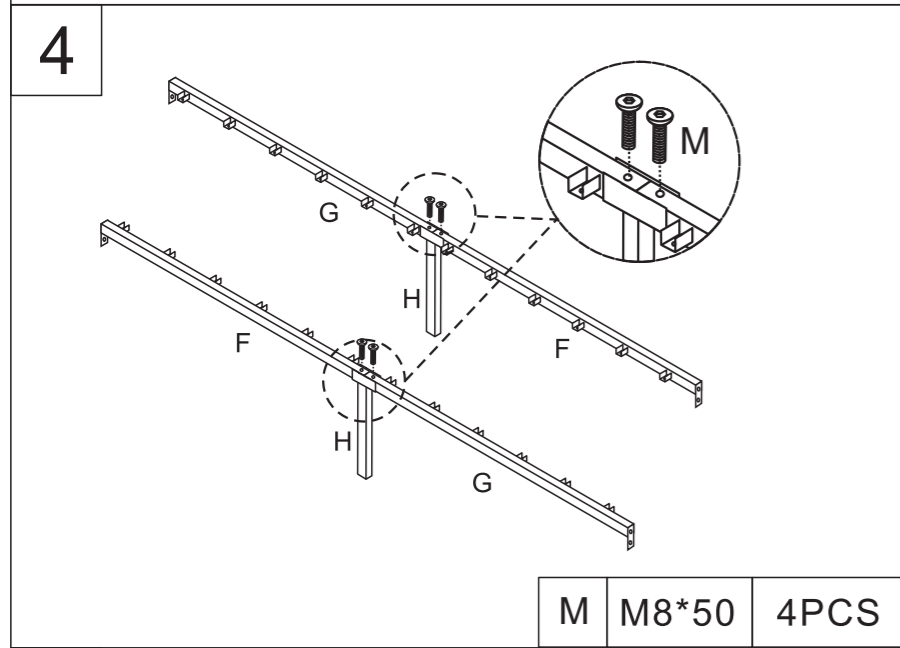
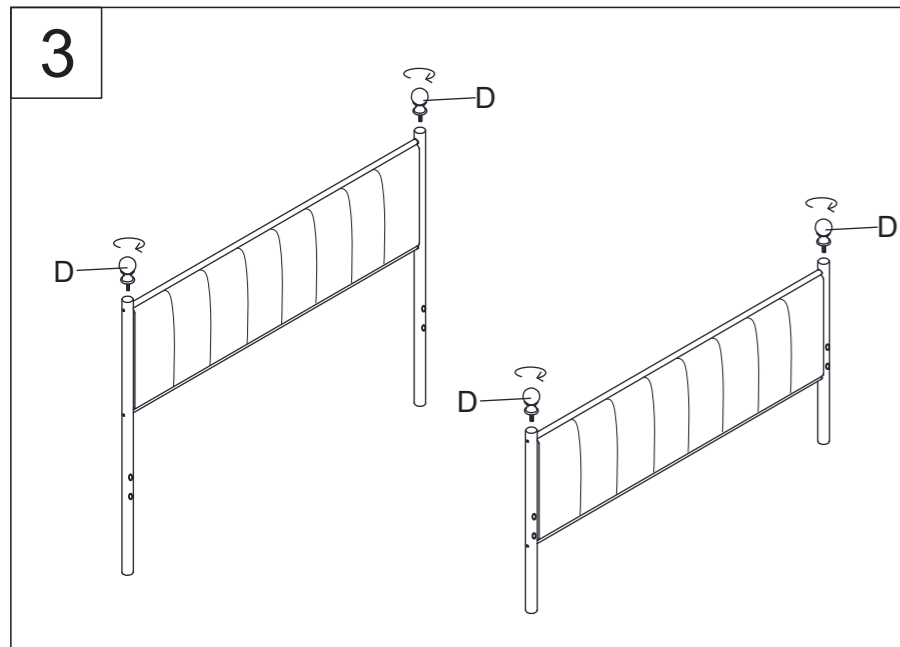

M M8*50 4PCS

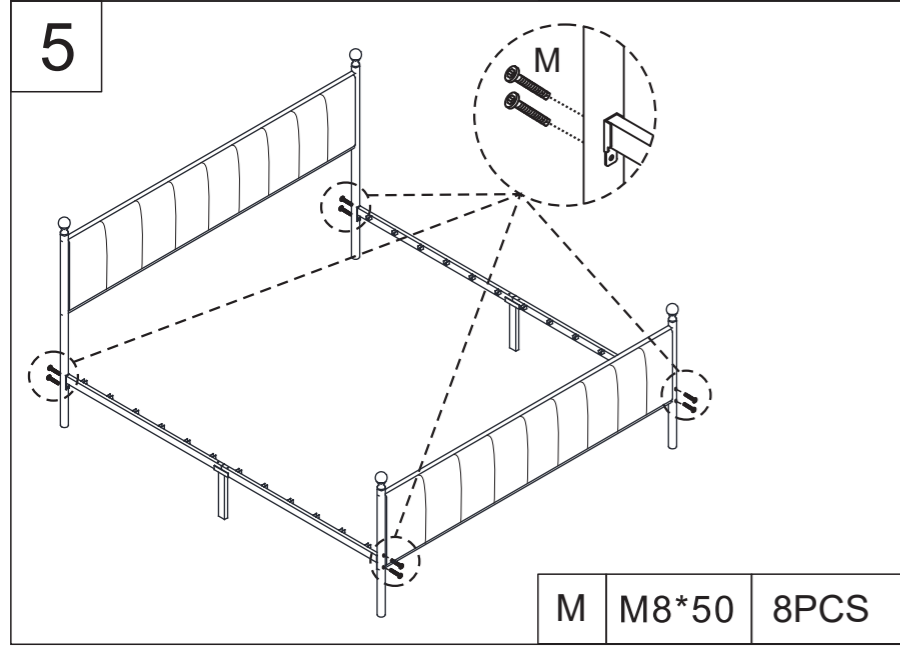

M M8*50 8PCS

4

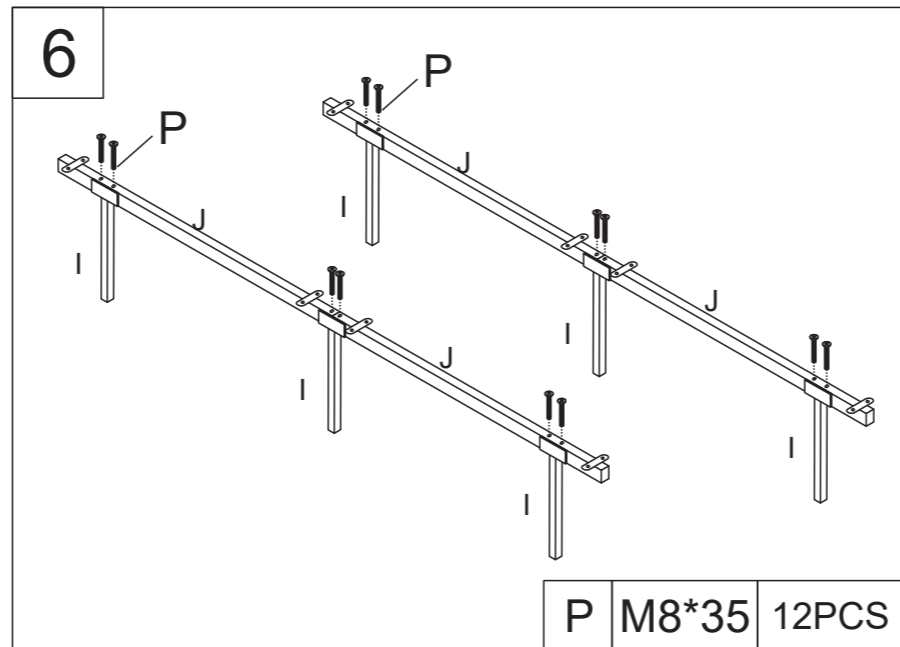

P M8*35 12PCS

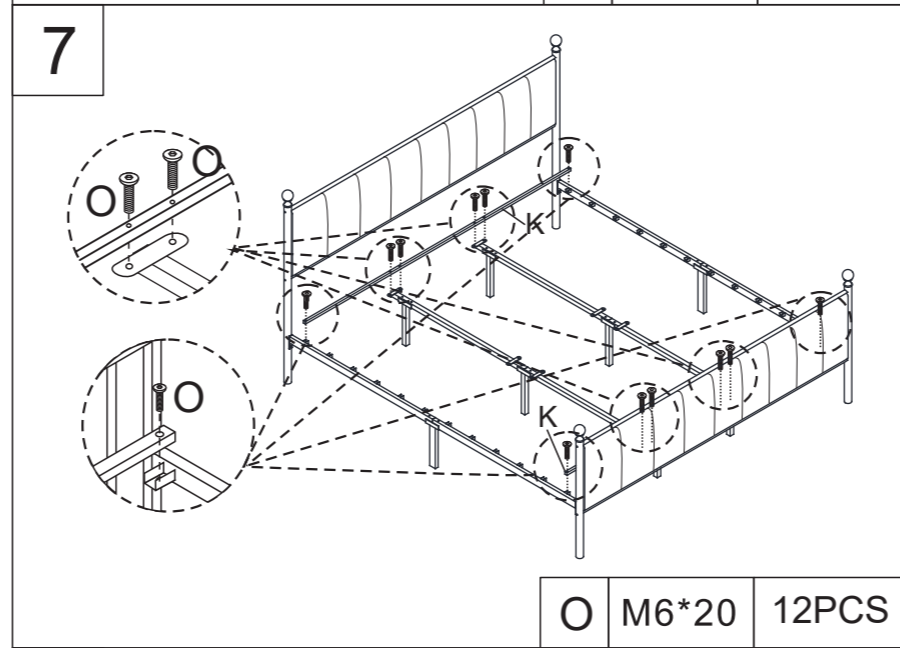

O M6*20 12PCS

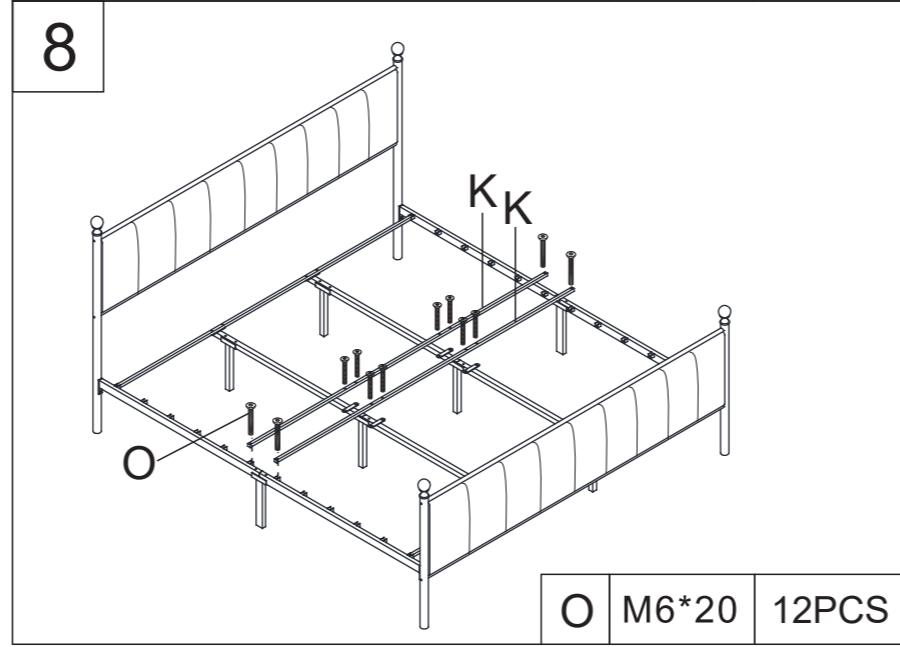

O M6*20 12PCS

5

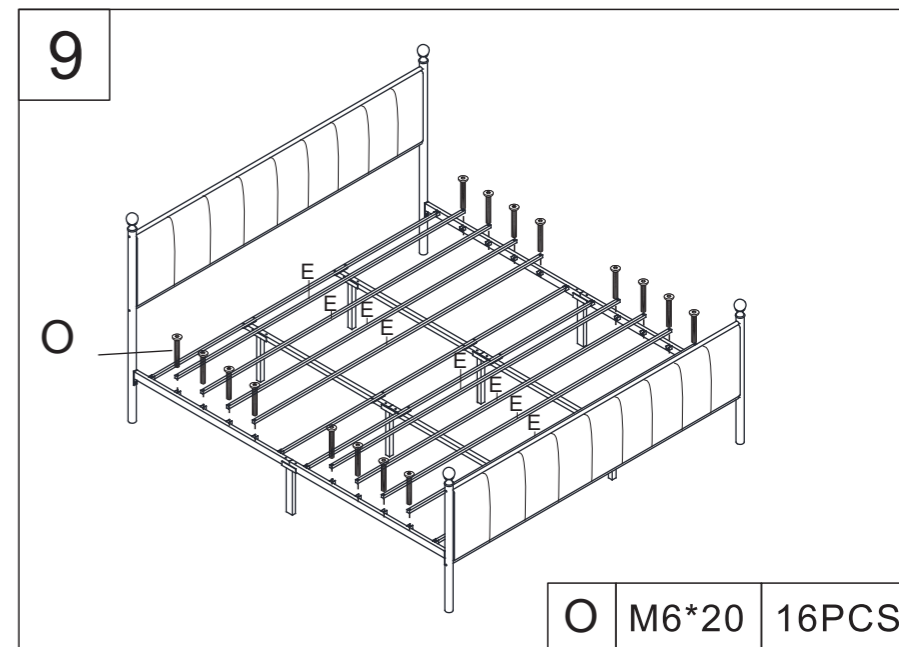

O M6*20 16PCS

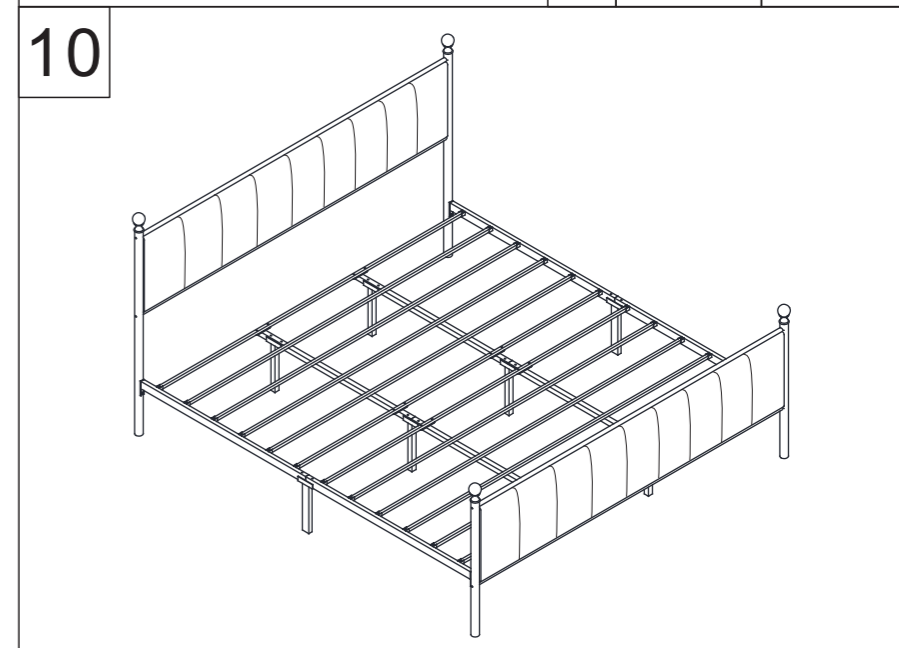

6