

JA25006

ASSEMBLY INSTRUCTION

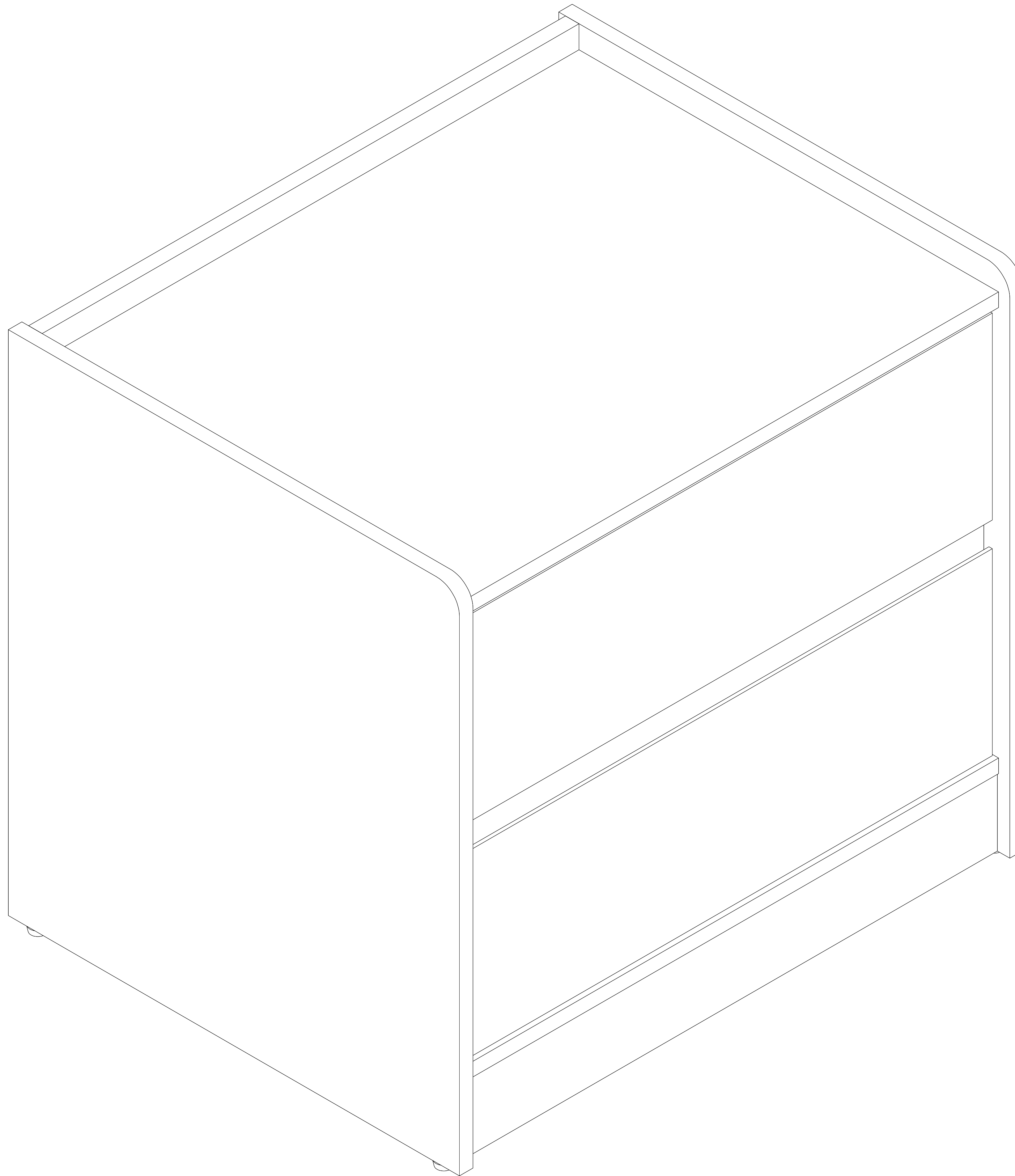
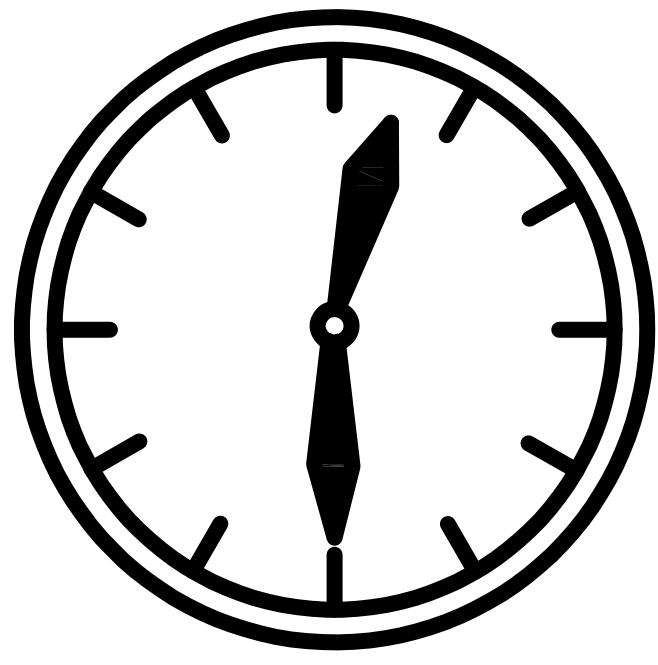
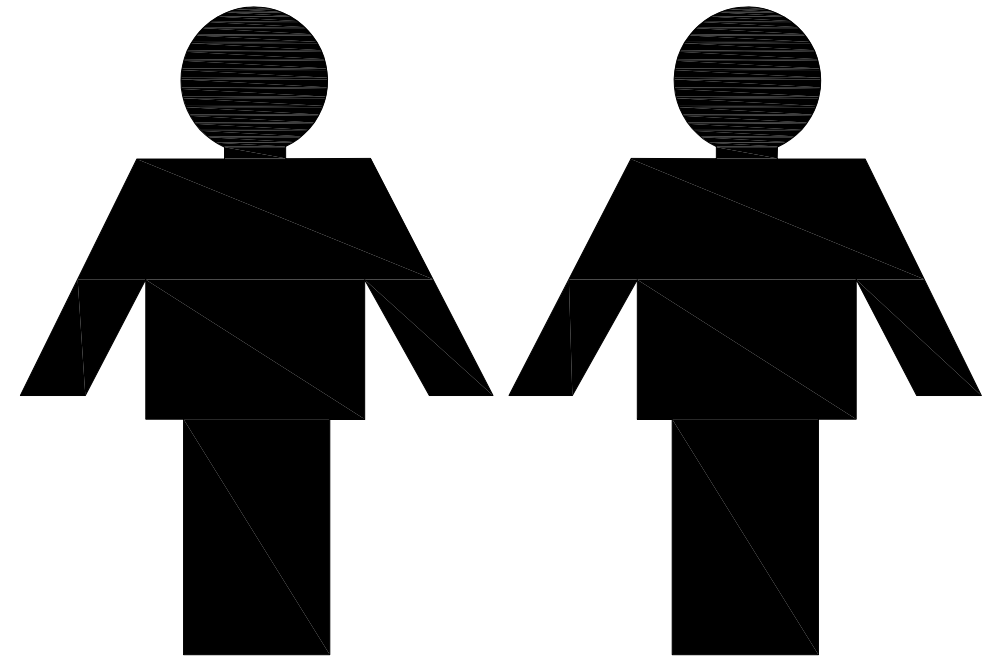

INTRODUCTION

Thank you for purchasing our products. Please read the instructions carefully before installation and keep it in a safe place for future reference. If you need any assistance or support, please feel free to contact our customer support team.

PRECAUTIONS

1. There are many components and accessories in the package. Each component and accessory is labeled with a letter or a number, check carefully before using any of them. Keep them away from children to prevent accidents.
2. Please install the product on a clean and soft underlay (such as carpet or cardboard) to avoid scratching or damaging the surface of the product.
3. The main components of the product are relatively heavy. Please pay attention to safety during installation.
4. The product is not stable during installation. Please do not move it randomly before it is completely installed.
5. This product requires two people to install.
6. If you have any questions during installation, please contact our customer service in time.

***PLEASE BE SURE TO FOLLOW THE INSTALLATION STEPS IN THE MANUAL TO AVOID UNNECESSARY LOSSES CAUSED BY IMPROPER INSTALLATION.**

***IF YOU NEED FURTHER ASSISTANCE, PLEASE CONTACT OUR CUSTOMER SERVICE ONLINE.**

USING CAM LOCK AND QUICKFIT

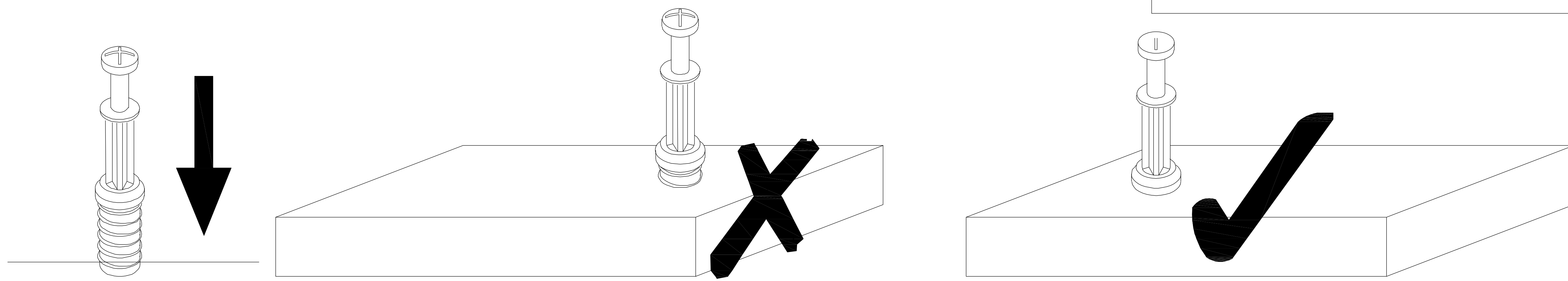

EN_QUICKFIT: Tighten quickfit until shoulder is flush with panel. Do not overtighten or undertighten.

FR_RACCORD RAPIDE: Faites serrer le raccord rapide jusqu'a ce que l'épaulement soit parfaitement encstre dans le panneau. Il ne faut ni trop serrer ni insuffisamment serrer.

ES_QUICKFIT: Apriete quickfit hasta que el hombro se descargue con el panel. NO lo sobreapriete ni lo apriete poco.

DE_QUICKFIT: Ziehen Sie den quickfit fest, bis die Schulter mit der Platte bundig ist. Bitte nicht zu fest oder zu schwach anziehen.

IT_MONTAGGIO RAPIDO: Stringere il montaggio rapido fino a quando la spalla e a filo con il pannello, non stringere troppo o troppo poco.

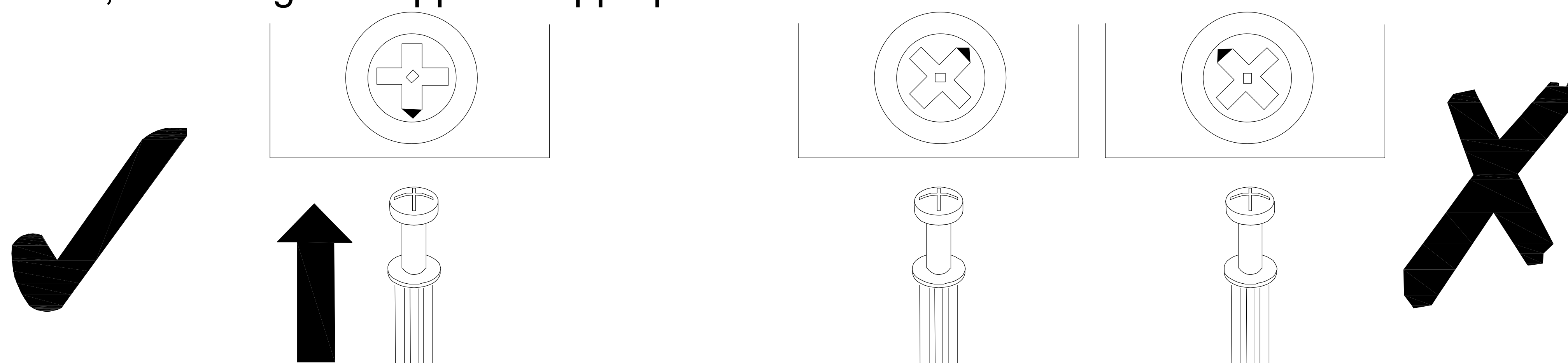

EN_CAM LOCK: When fitting cam lock, ensure starting position is correct before you insert connecting quickfit.

FR_SERRURE BATTEUSE: Avant d'insérer la serrure batteuse, veillez a la bonne orientation avant d'insérer le raccord rapide,

ES_CIERRE DE LA CAMARA: Cuando instale el cierre de la camara, asegurese de que la posicion de inicio es correcta antes de que inserte el quickfit conector,

De_CAM-LOCK: Achten Sie bei der Montage des Cam-locks auf die richtige Ausgangsposition, bevor Sie den Quickfit einsetzen.

IT_BLOCCAGGIO A CAMMA: Quando si monta il bloccaggio a camma, assicurarsi che la posizione iniziale sia corretta prima di inserire il montaggio rapido di collegamento.

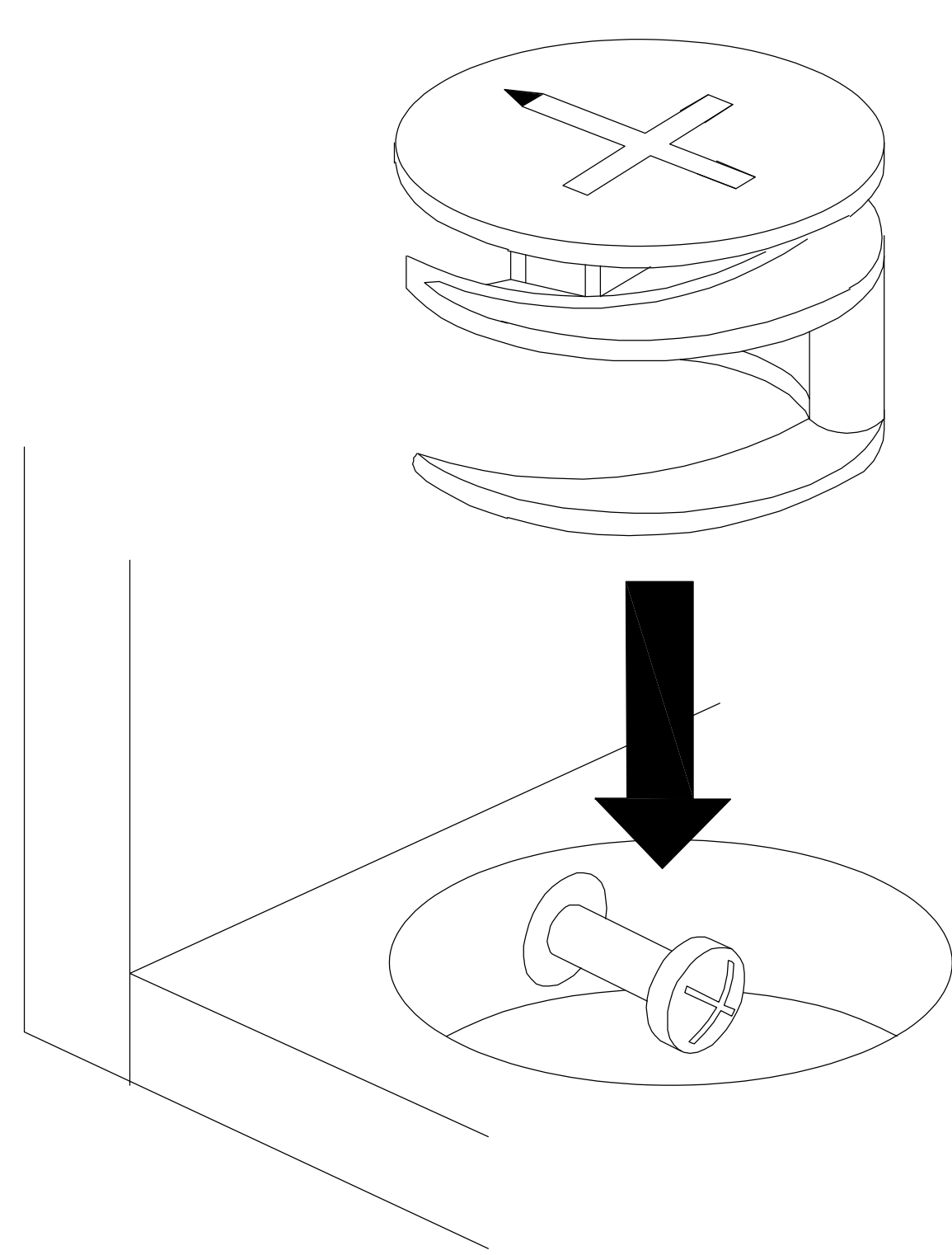

EN_Quickfit head should be in the centre of the cam lock when the two panels are joined.

Cam lock should be inserted before quickfit.

FR_Lorsque les deux panneaux sont assembles, la tete du raccord rapide doit reposer au centre de la serrure batteuse.

Il faut inserer la serrure batteuse avant le raccord rapide.

ES_EL cabezal del quickfit debe estar en el centro del cierre de la camara cuando se unan los dos paneles.

Se debe insertar el cierre de la camara antes que el quickfit.

DE_Der Quickfit-Kopf sollte sich in der Mitte des Cam-locks befinden, wenn die beiden Platten zusammengefügt sind.

Der Cam-lock sollte vor dem Quickfit eingesetzt werden.

IT_La testa del montaggio rapido deve trova rsi al centro del bloccaggio a camma quando i due pannelli sono uniti.

Il Bloccaggio a Camma deve essere inserito prima del montaggio rapido.

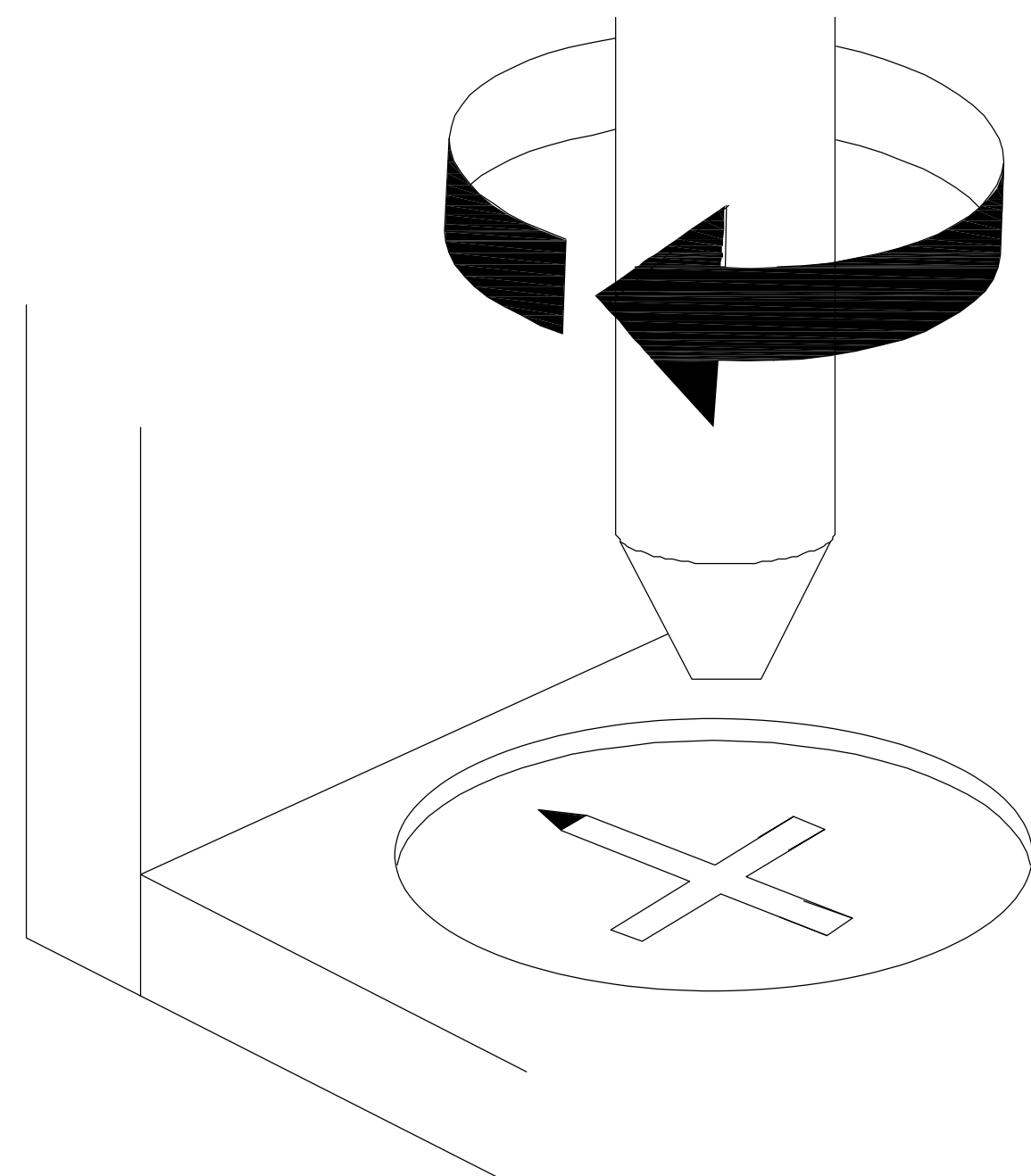

EN_Turn cam lock clockwise to tighten.

FR_Faites tourner la serrure batteuse dans le sens des aiguilles d'une montre pour la resserrer.

ES_Gire el cierre de la camara en sentido horario para apretarlo.

DE_Drehen Sie den Cam-Lock im Uhrzeigersinn, um ihn festzuziehen.

IT_Rutotare il bloccaggio a camma in senso oragio per stringere.

PARTS LIST

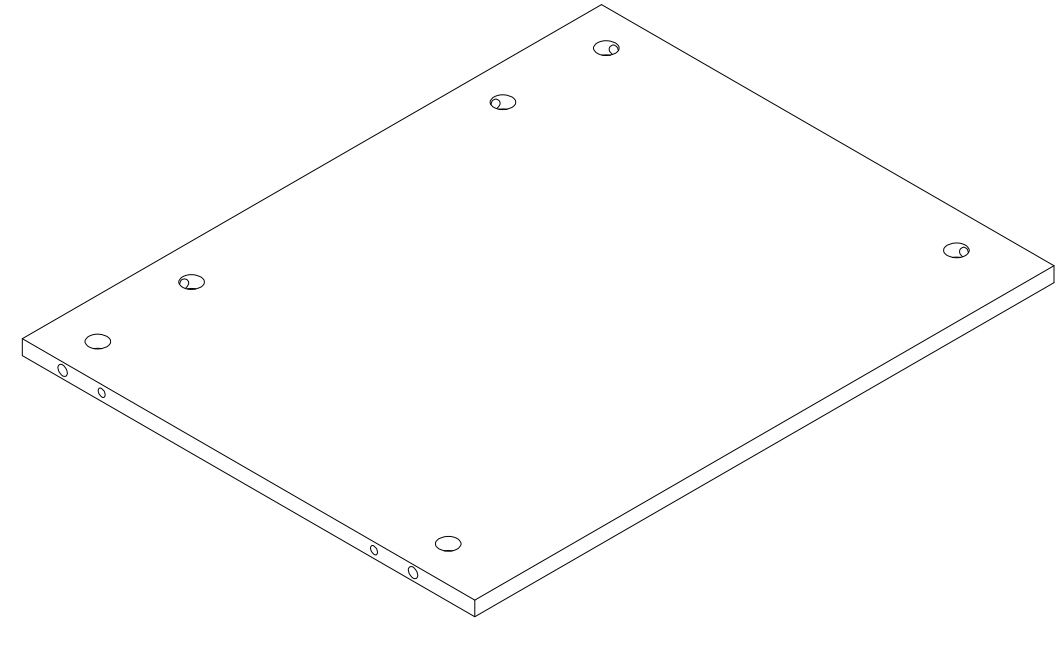
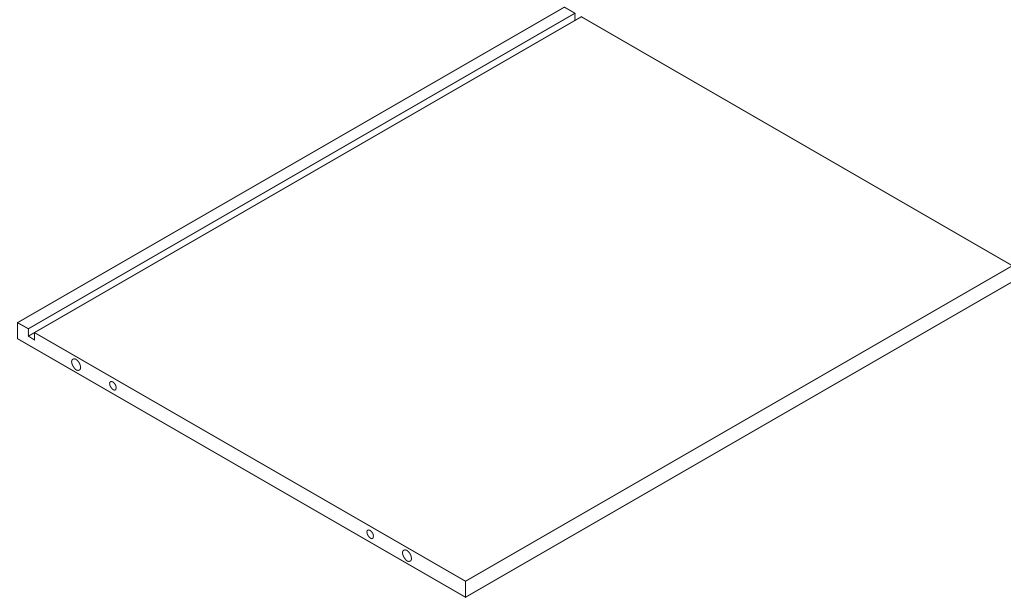
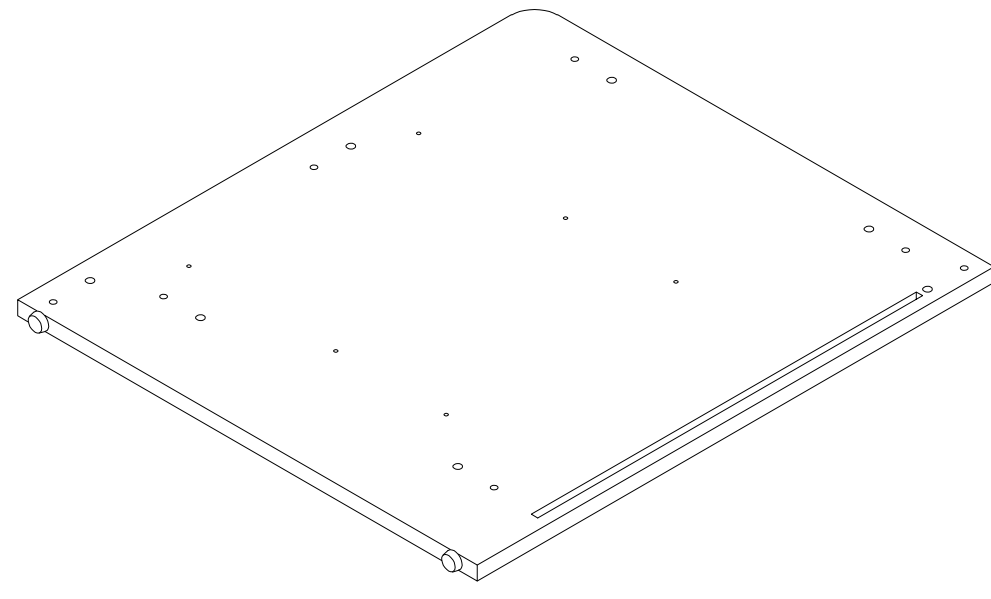
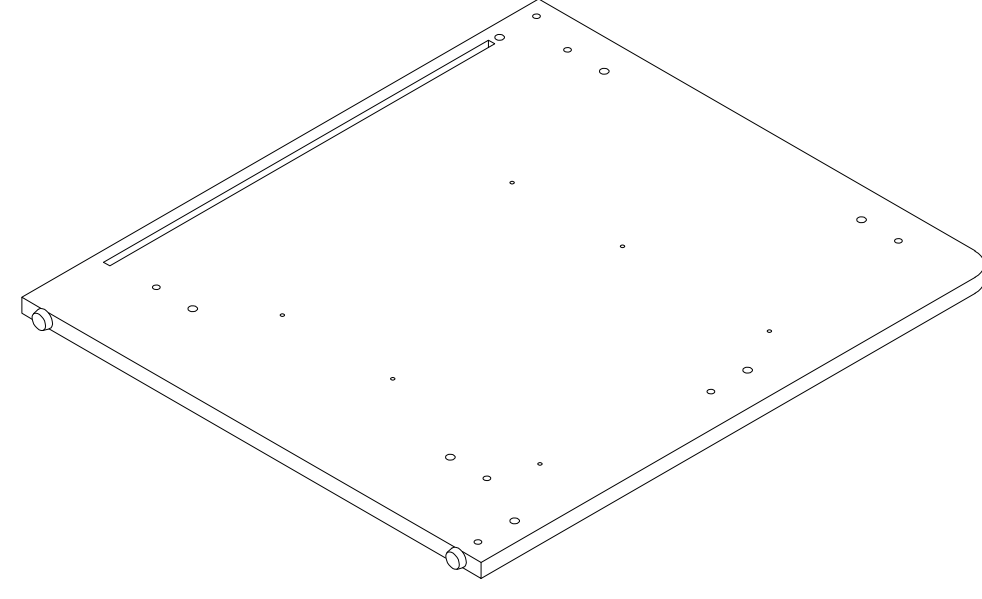
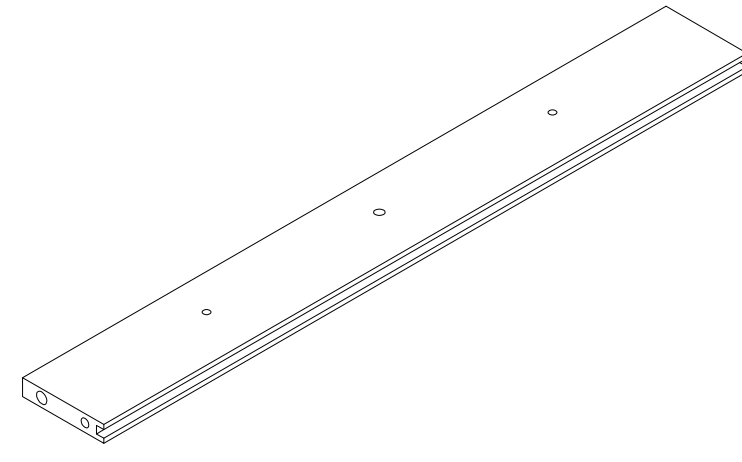
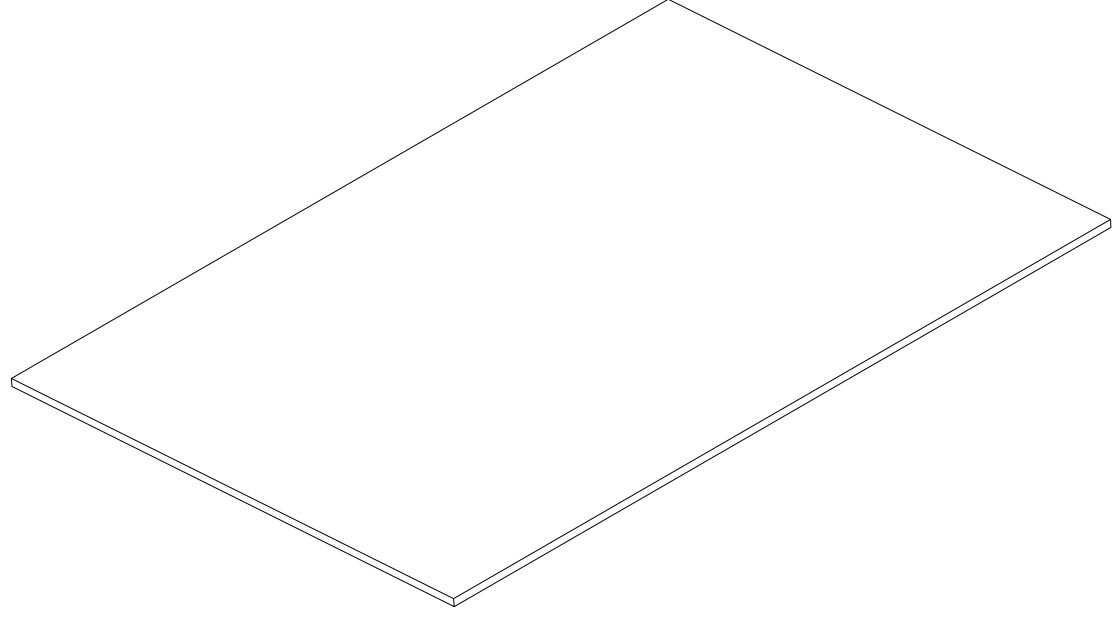
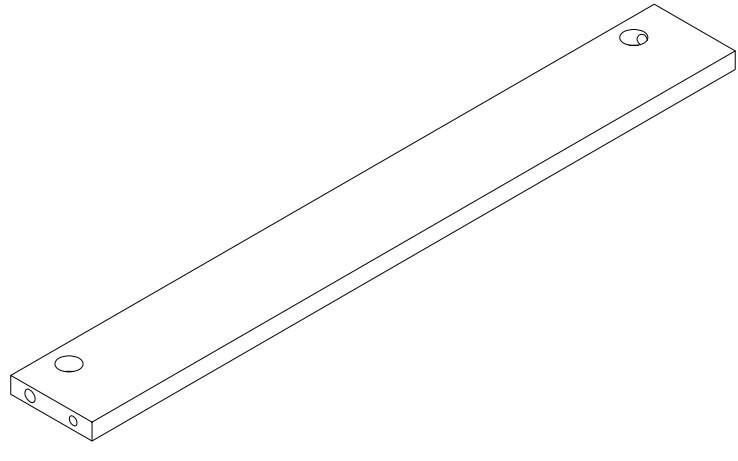
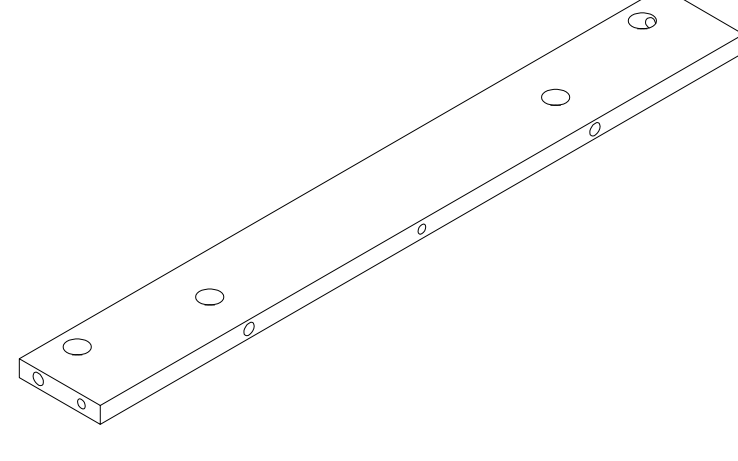
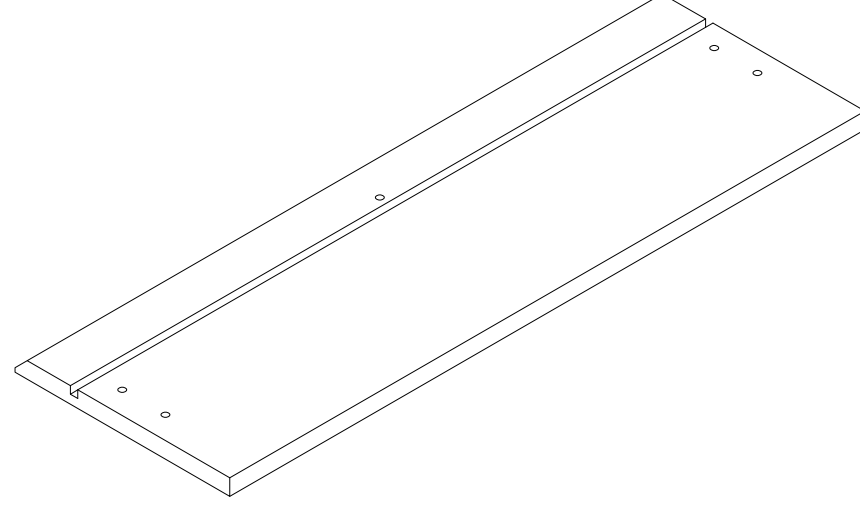
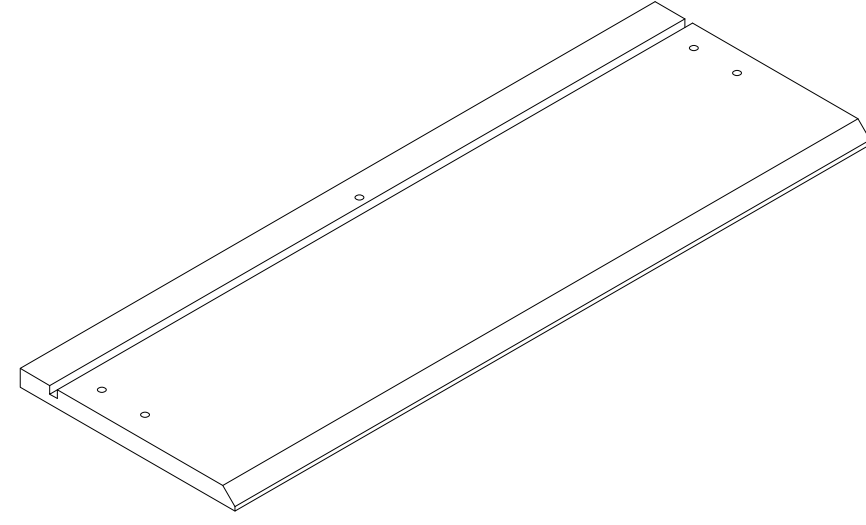
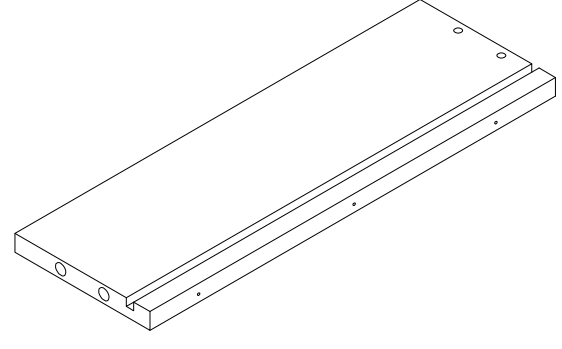
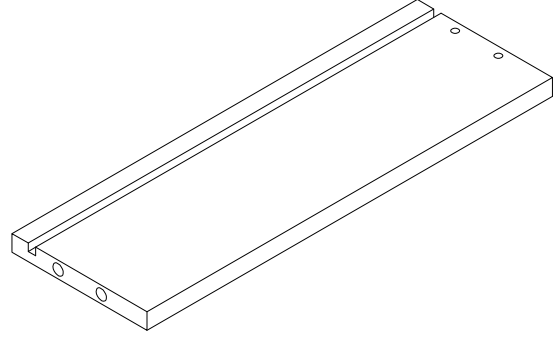
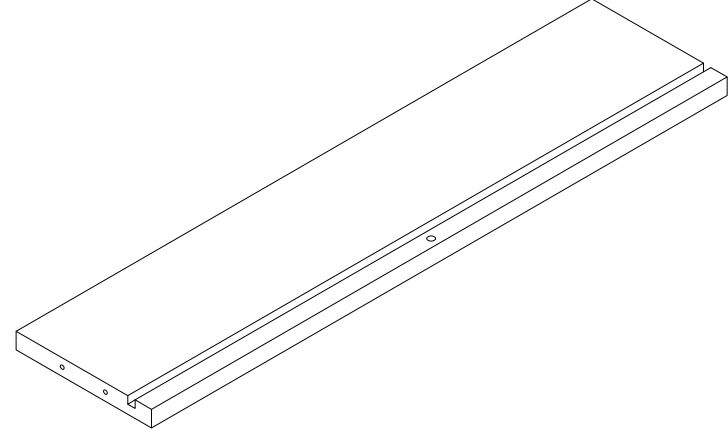
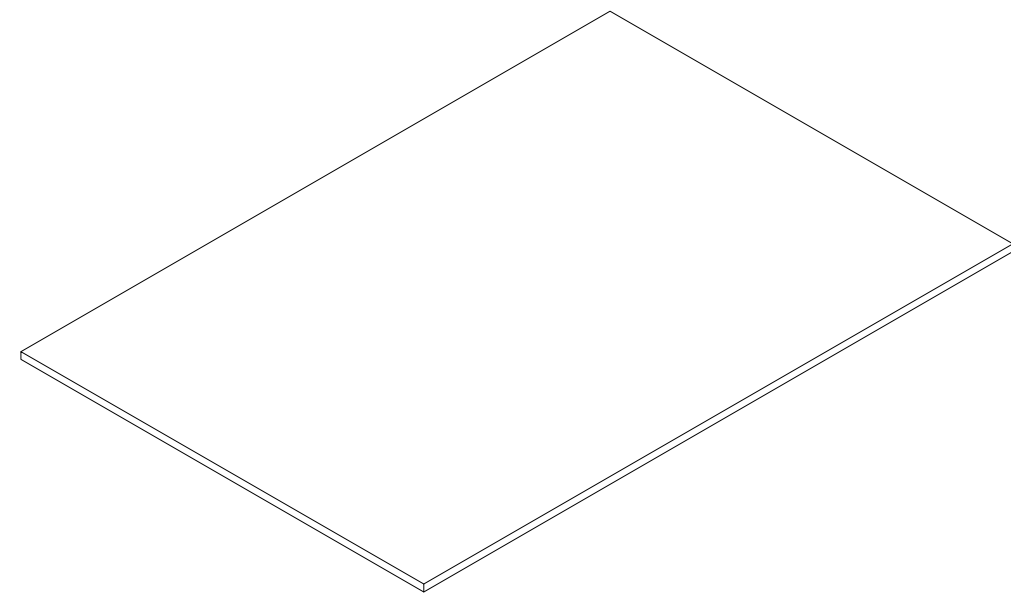
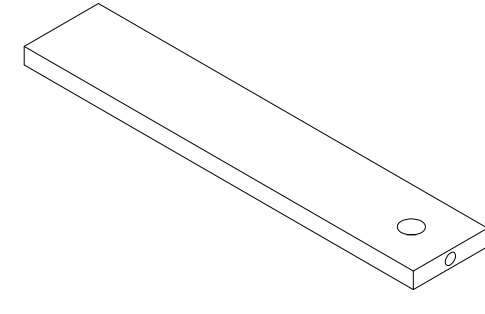
1 x1PC 	2 x1PC 	3 x1PC 	4 x1PC 	5 x1PC 
6 x1PC 	7 x1PC 	8 x1PC 	9 x1PC 	10 x1PC 
11 x2PCS 	12 x2PCS 	13 x2PCS 	14 x2PCS 	15 x2PCS 

HARDWARE LIST

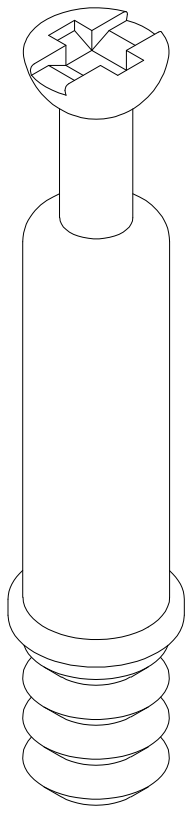
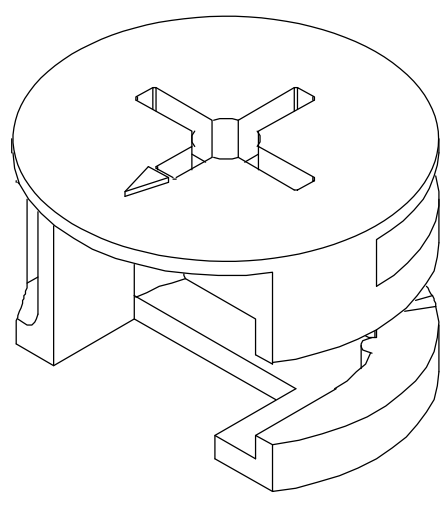
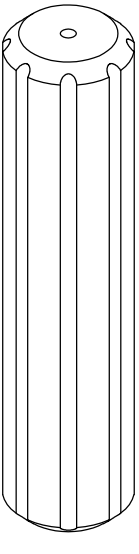
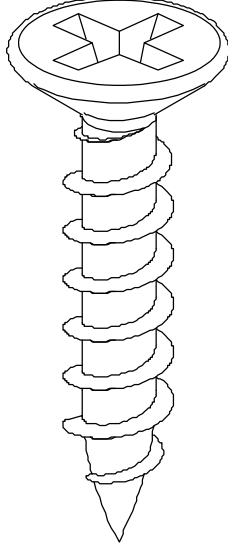
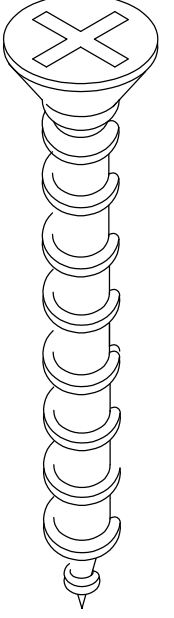
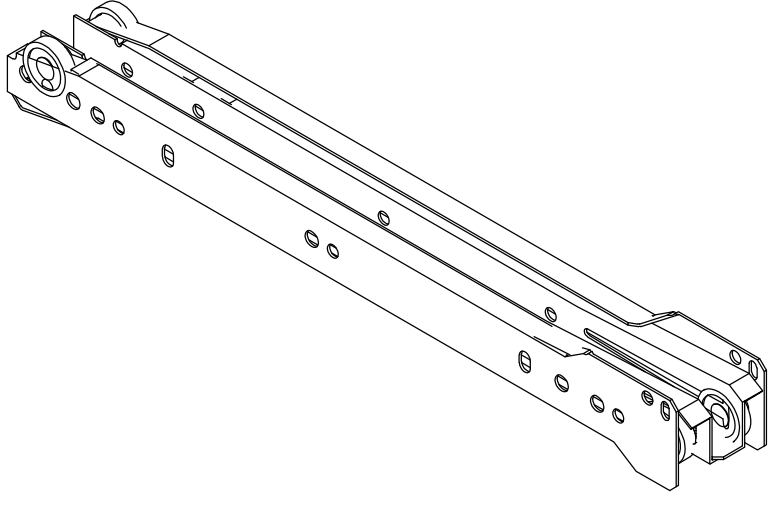
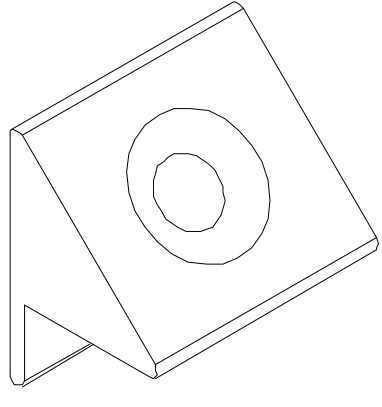
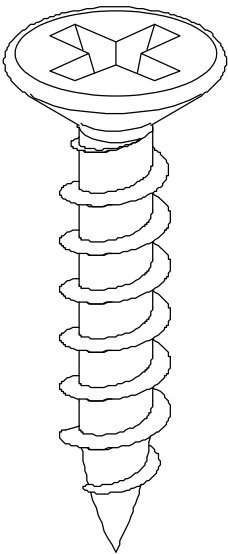
A  28+1PCS	B  28+1PCS	C  Ø6x30mm 16+1PCS	D  M3x12mm 24+1PCS	E  M3.5x30mm 10+1PCS
F  2PCS	G  4PCS	H  M3x16mm 4PCS		

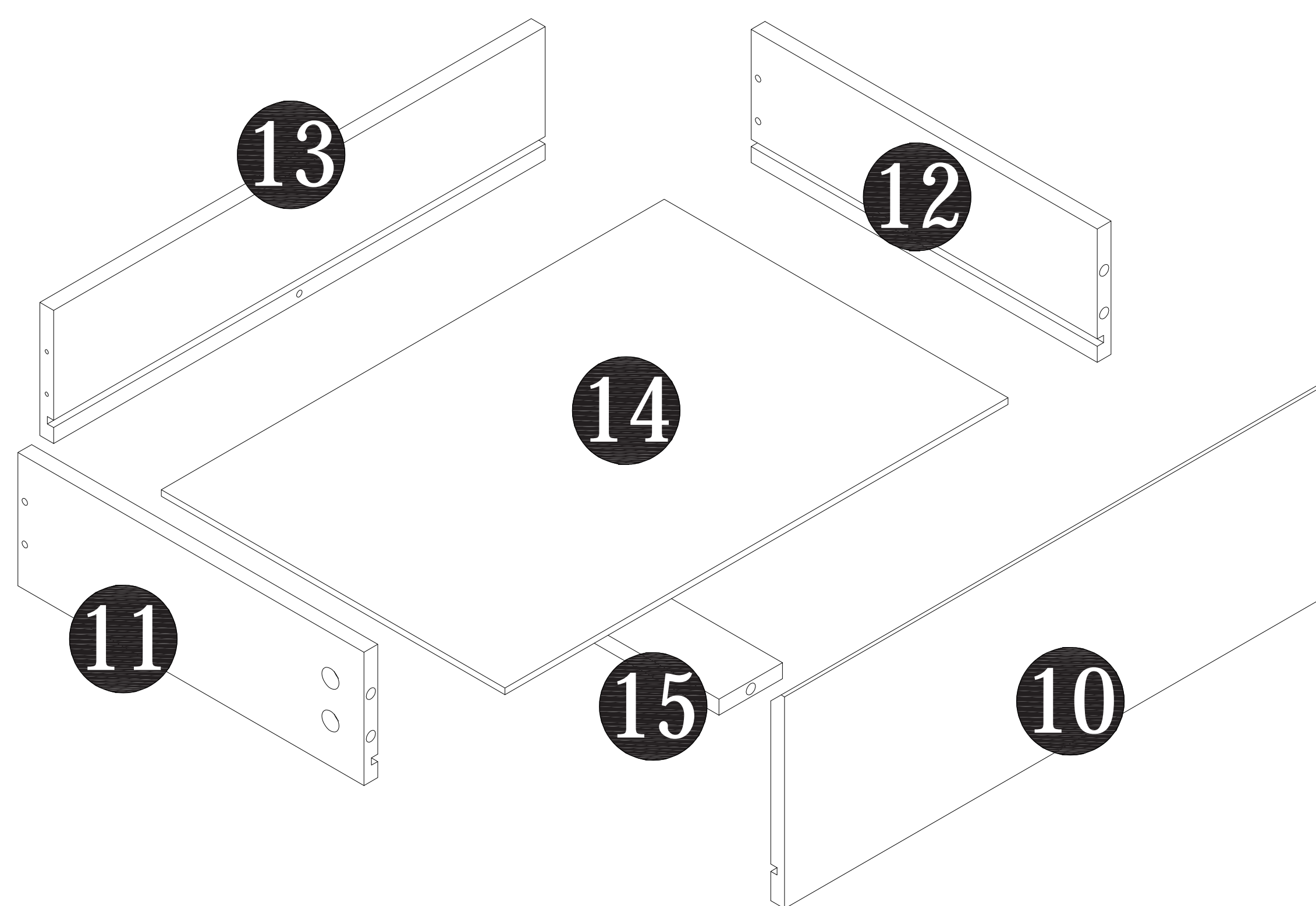
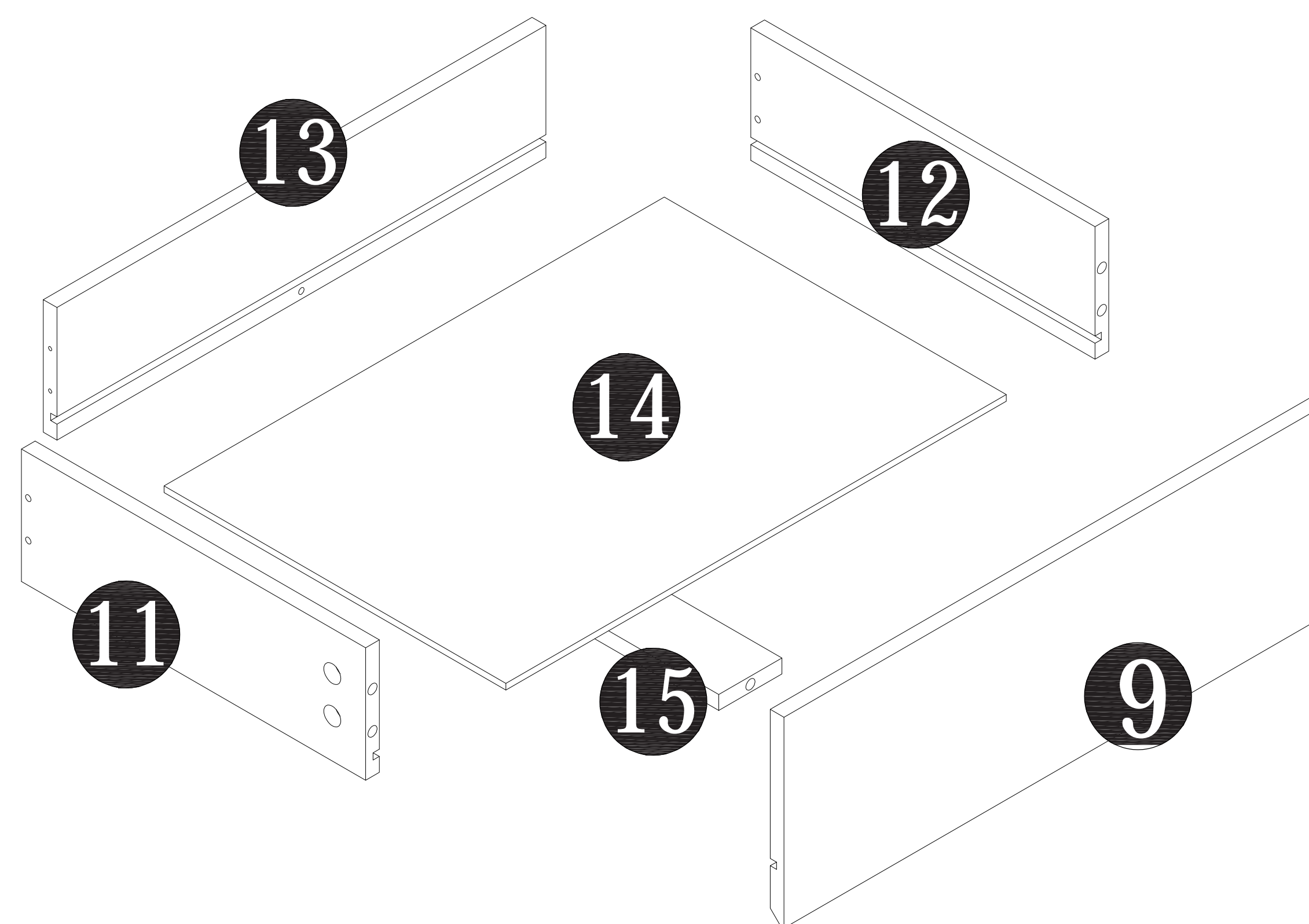
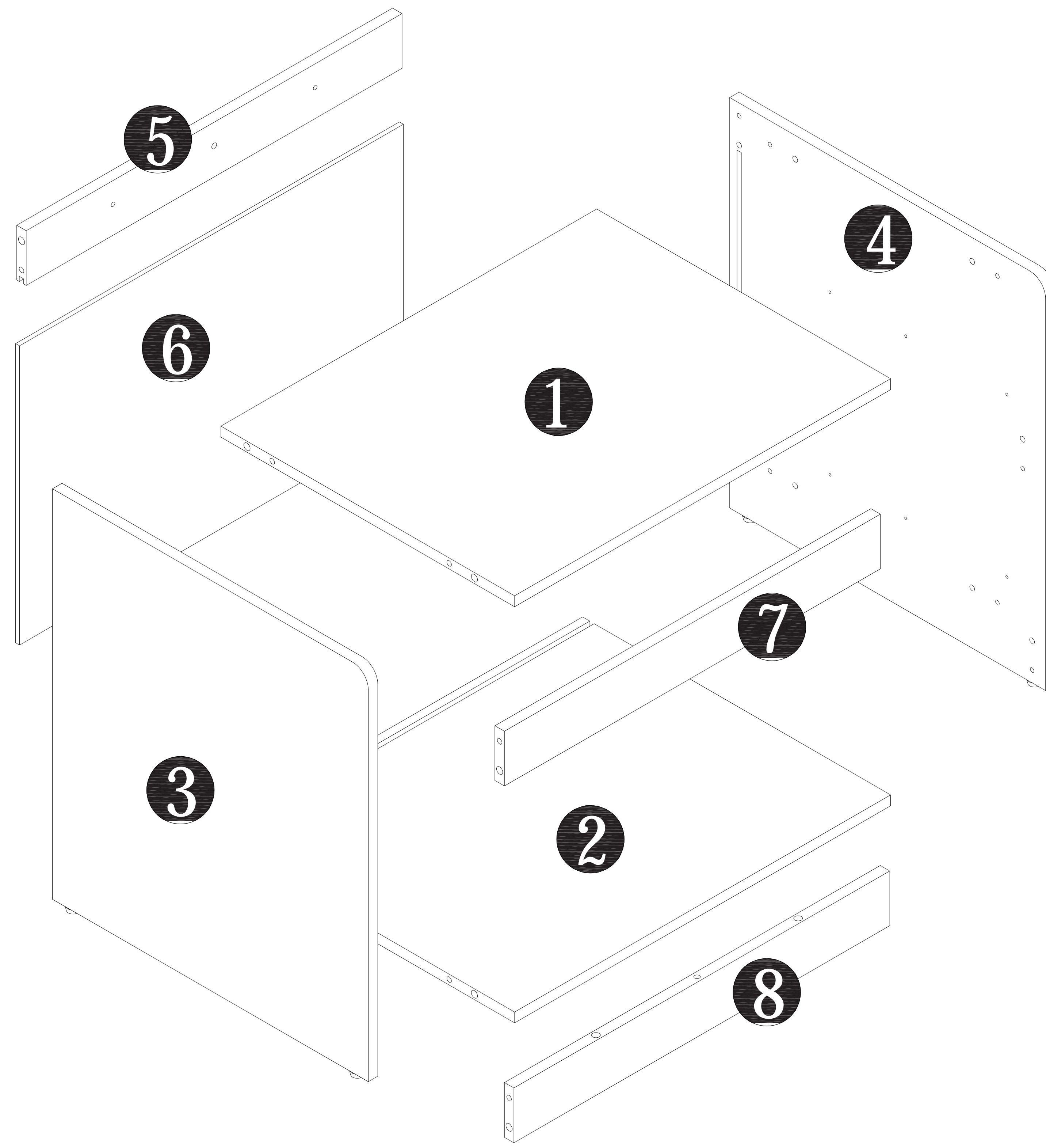

Step 1.

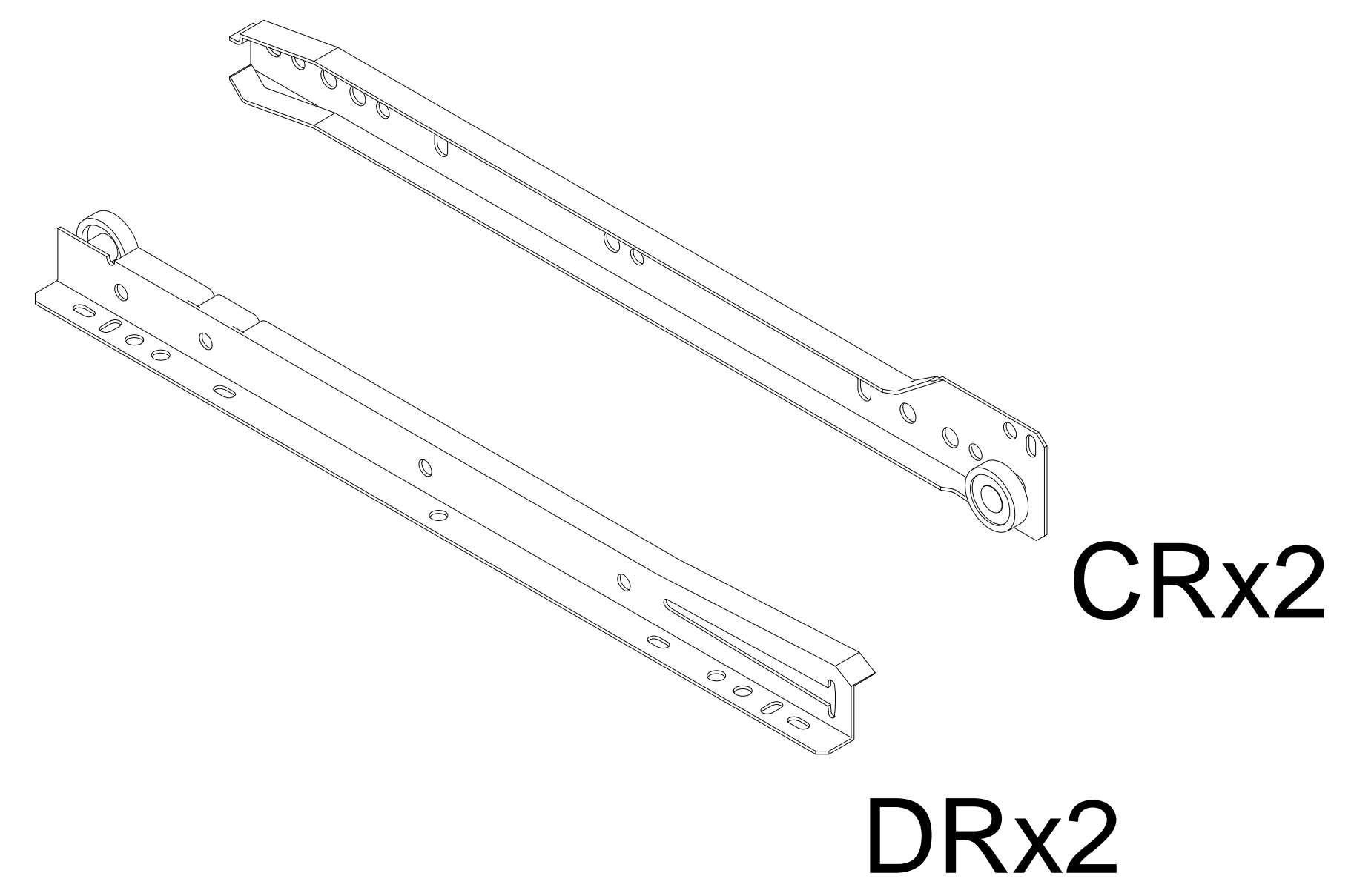
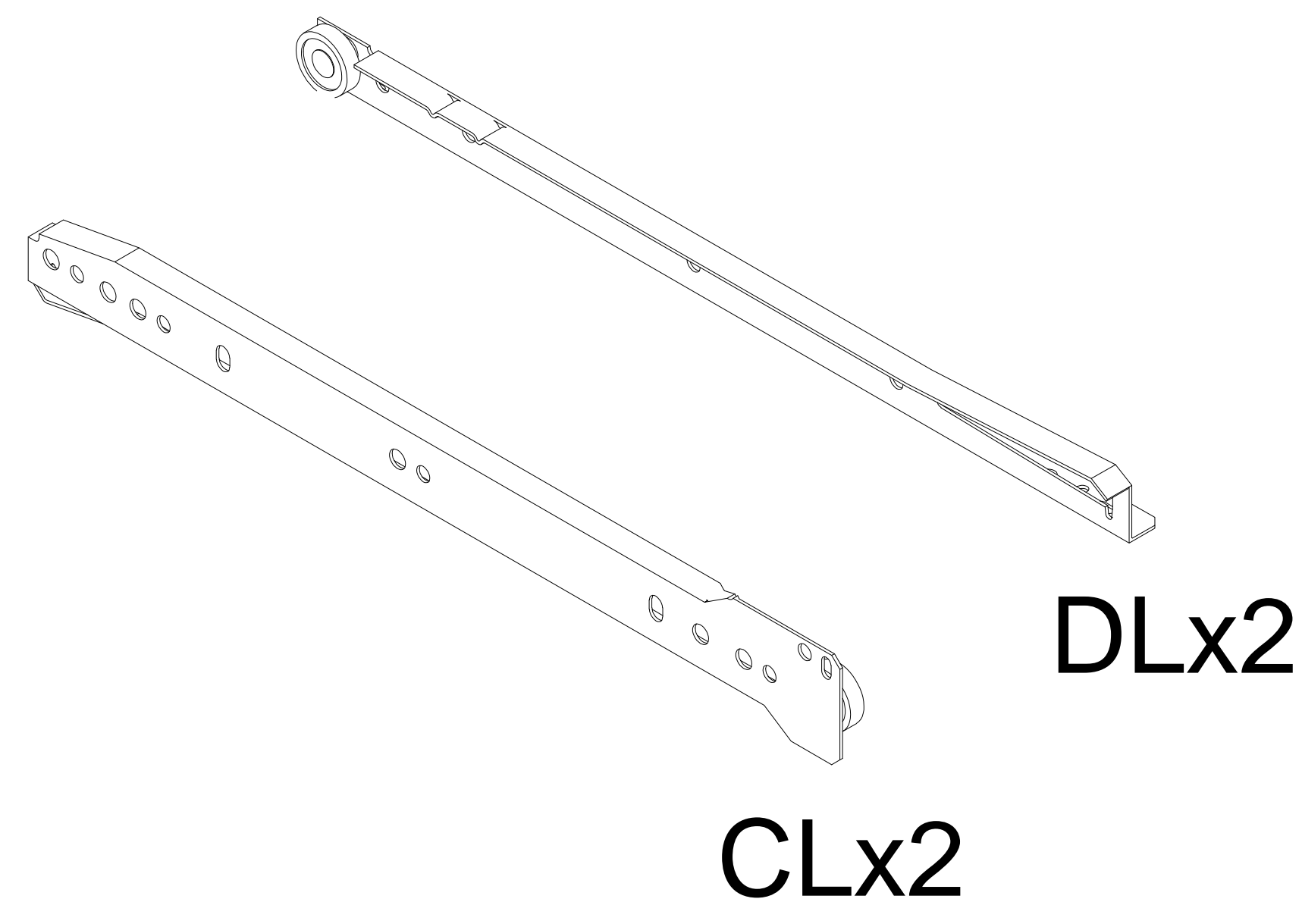
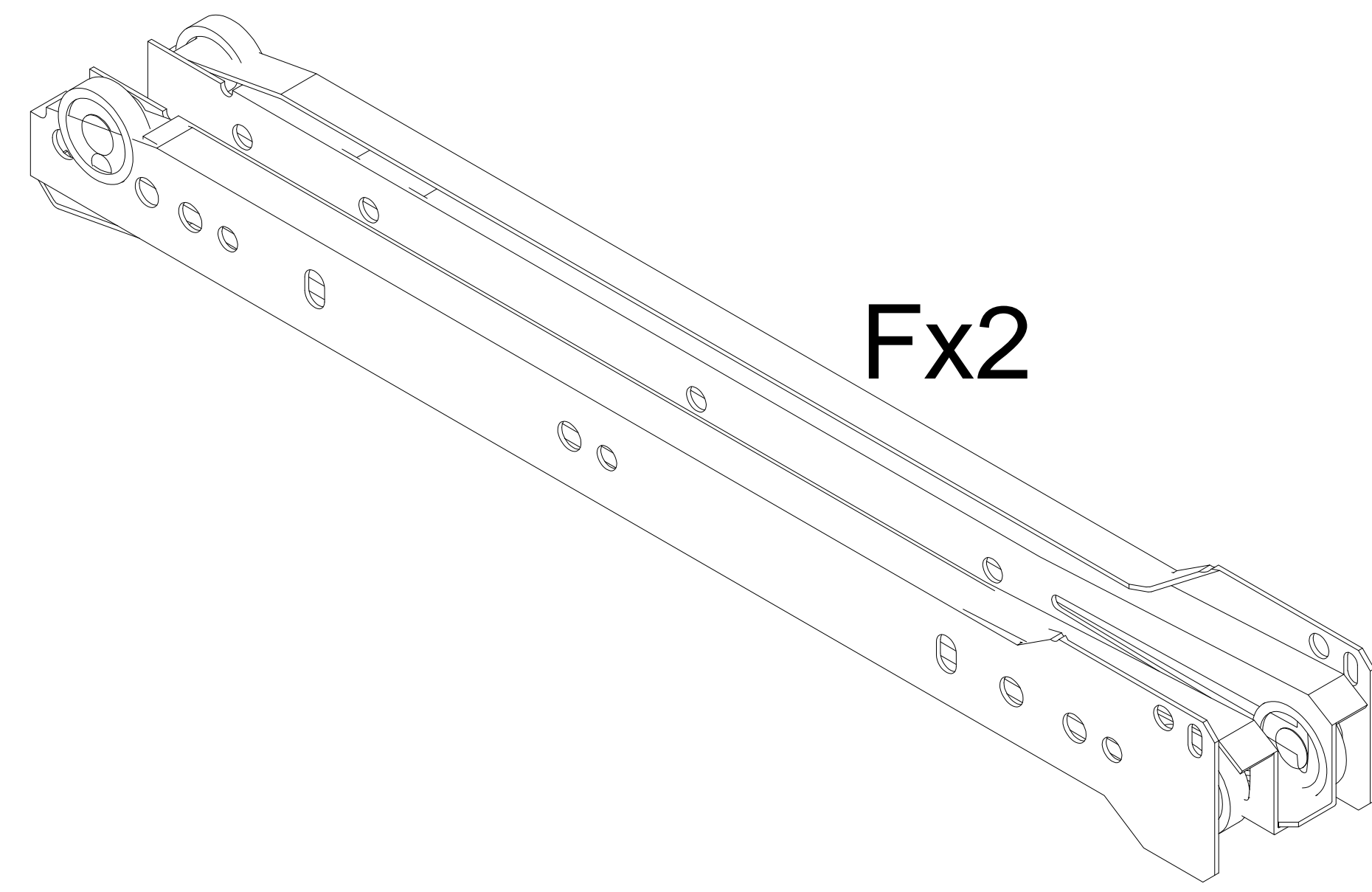
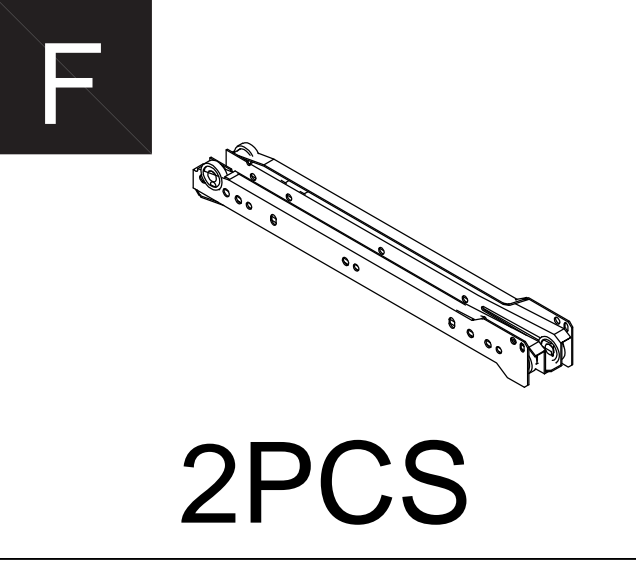

Step 2.

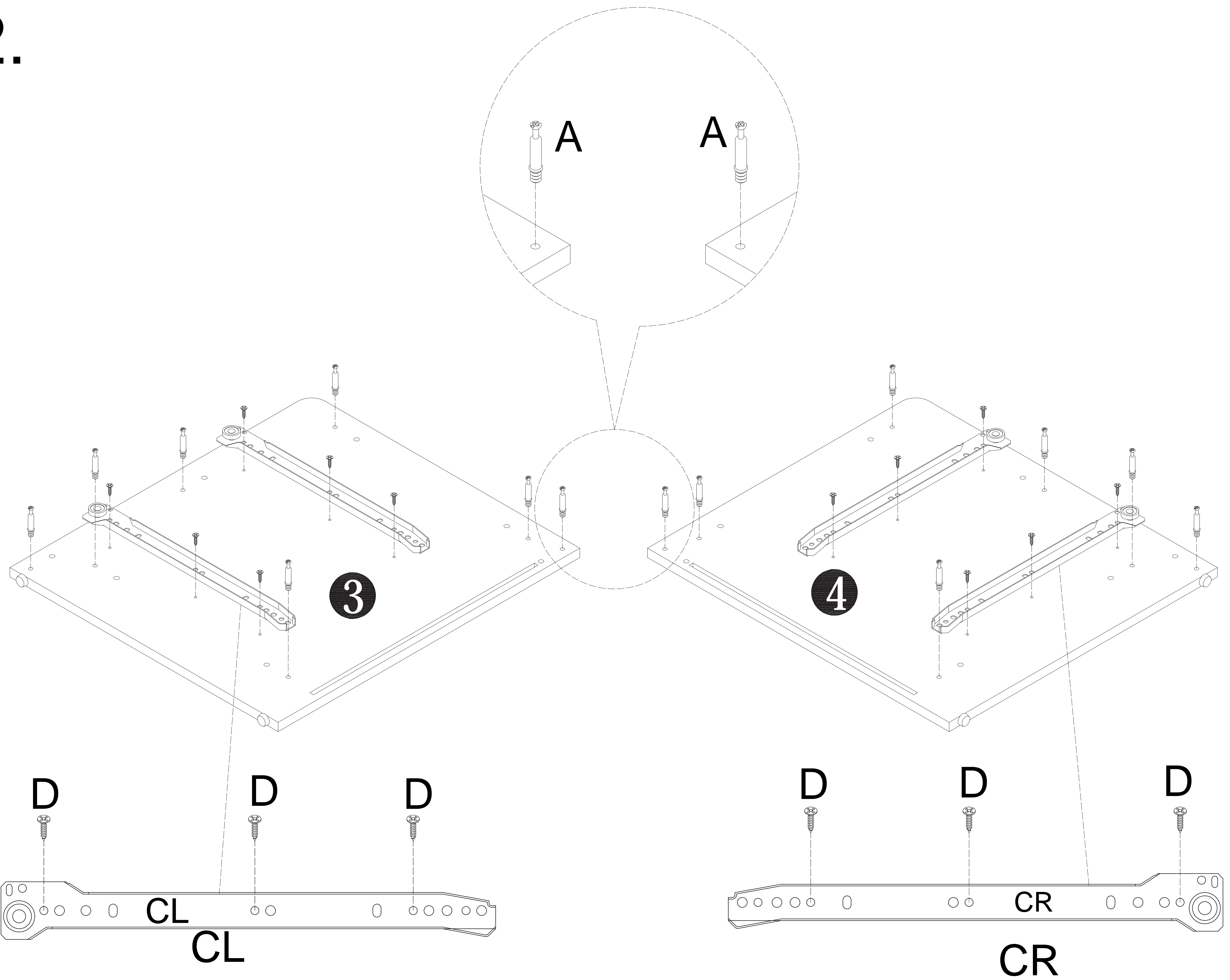
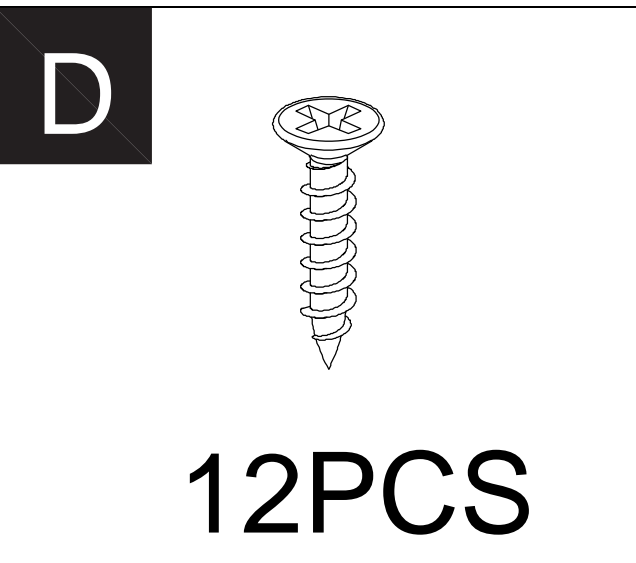
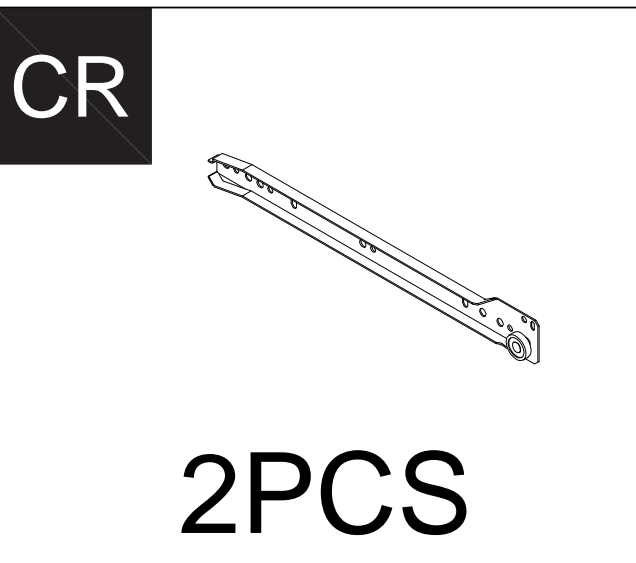
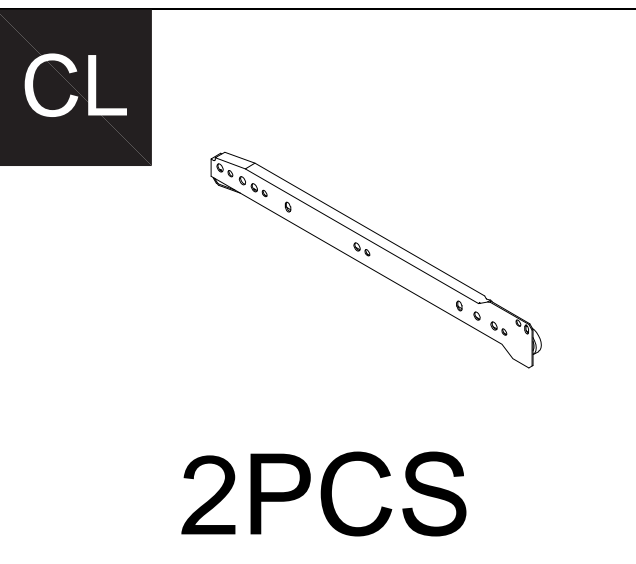
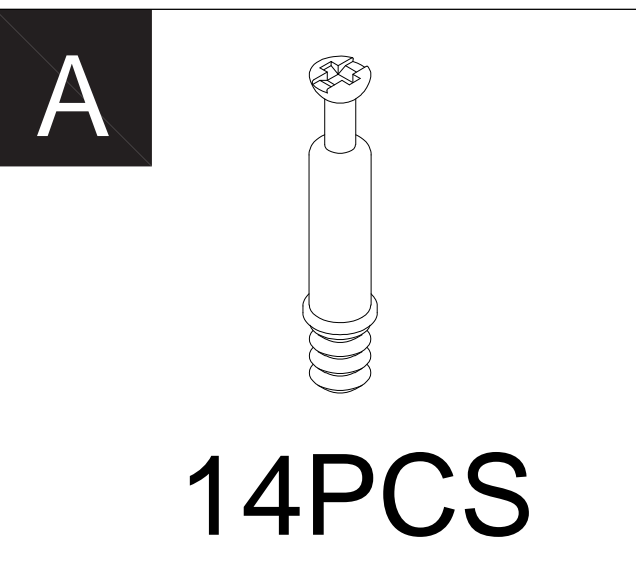

Step 3.

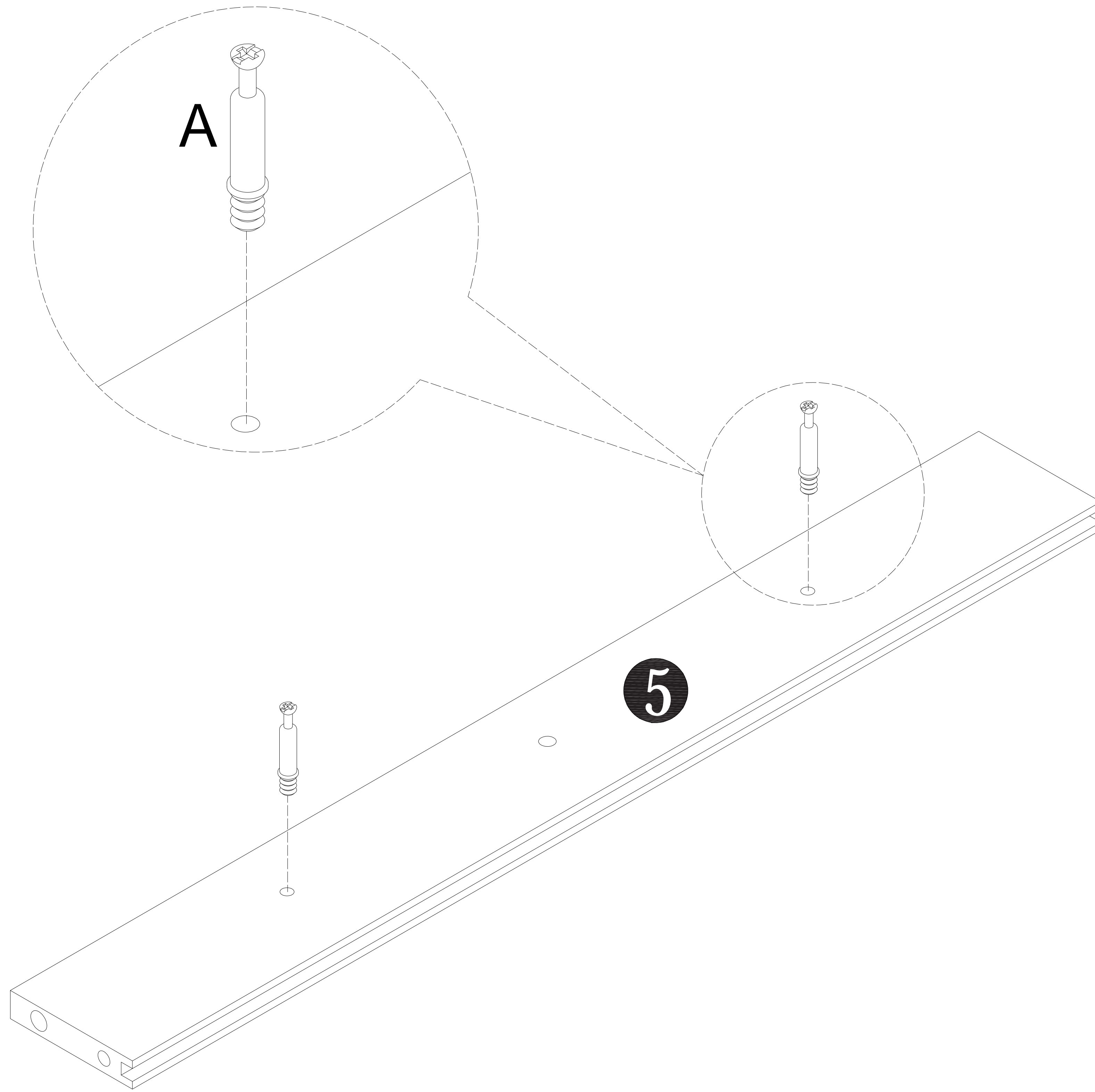
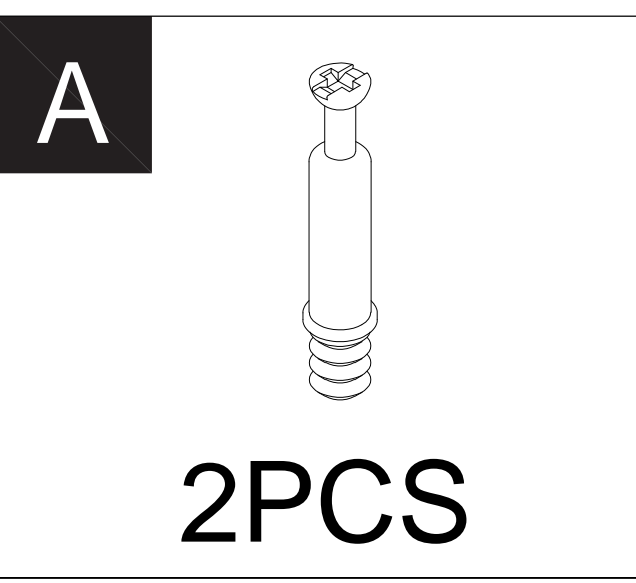

Step 4.

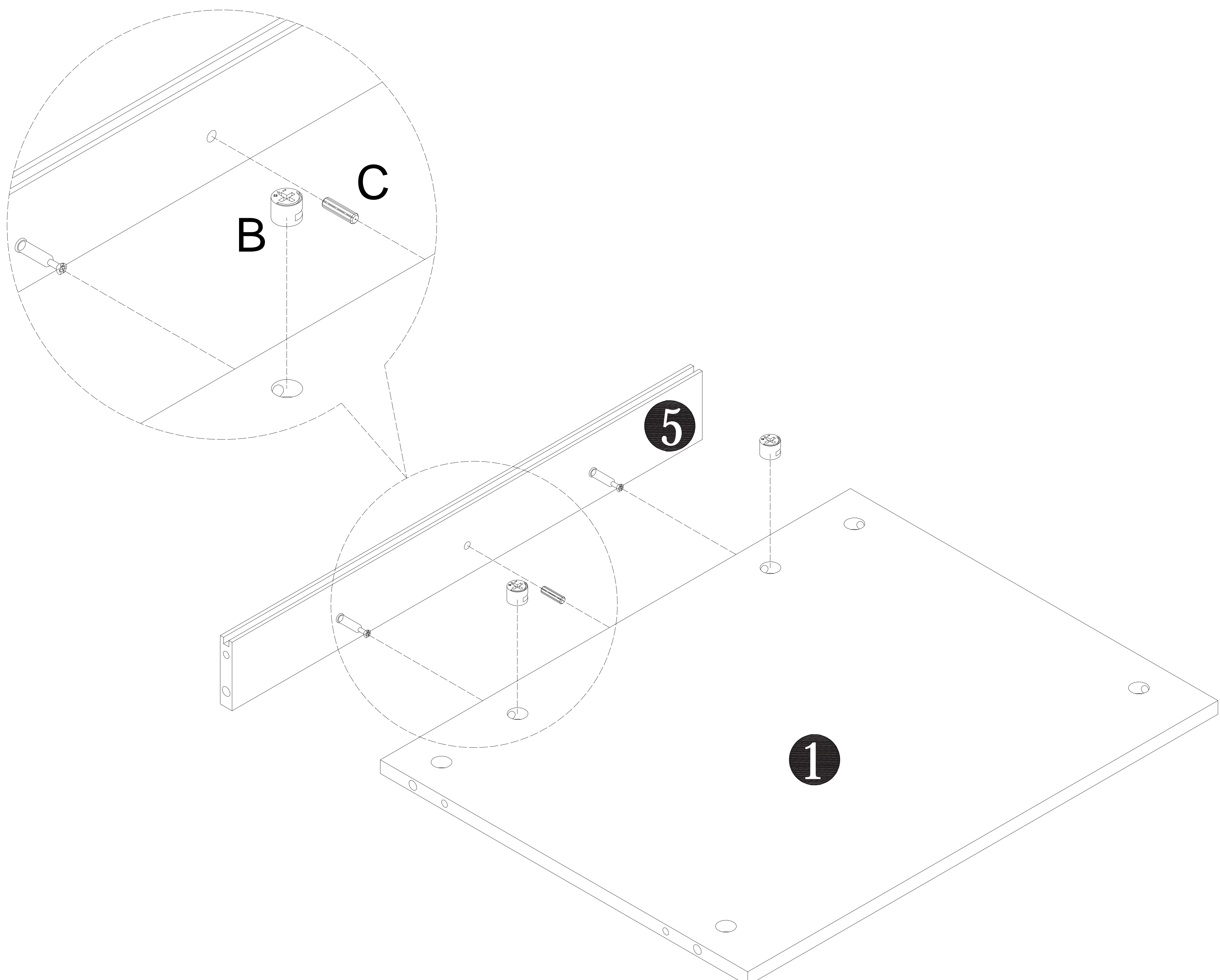
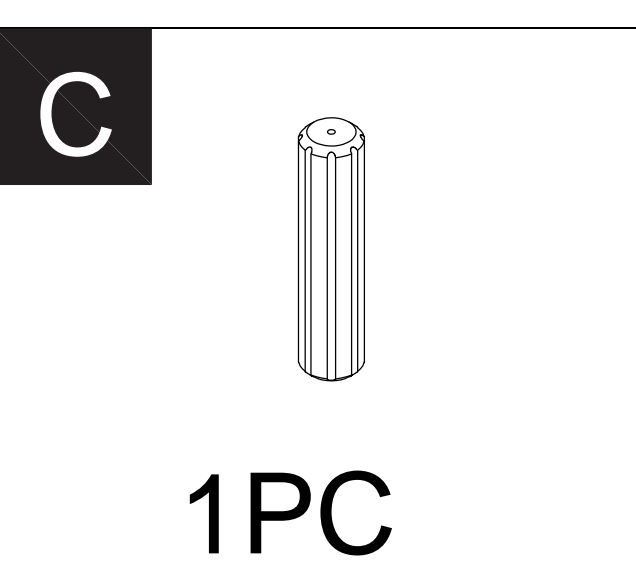
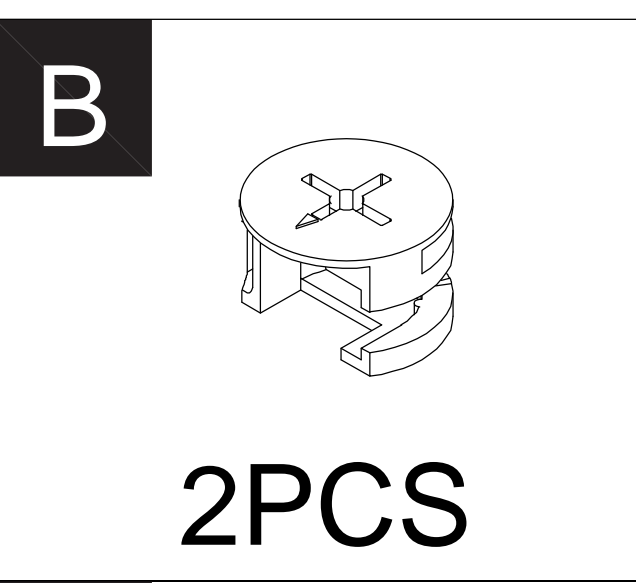

Step 5.

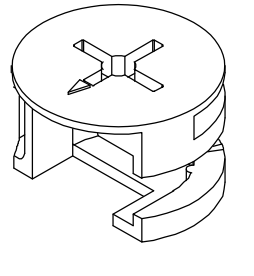
B

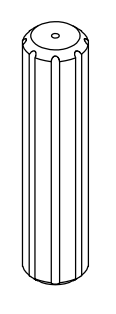
3PCS

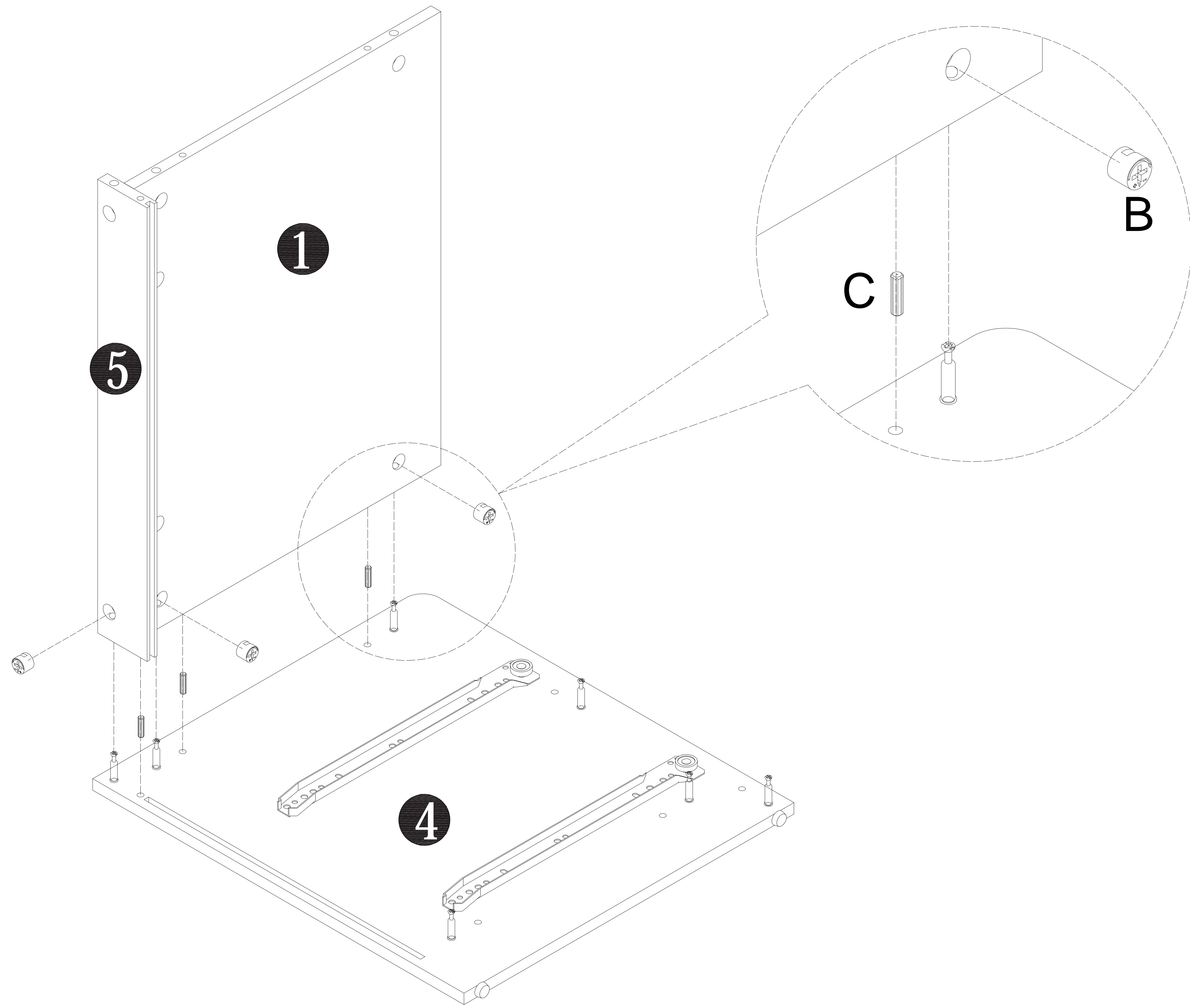
C

3PCS

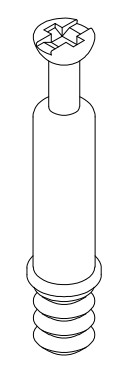

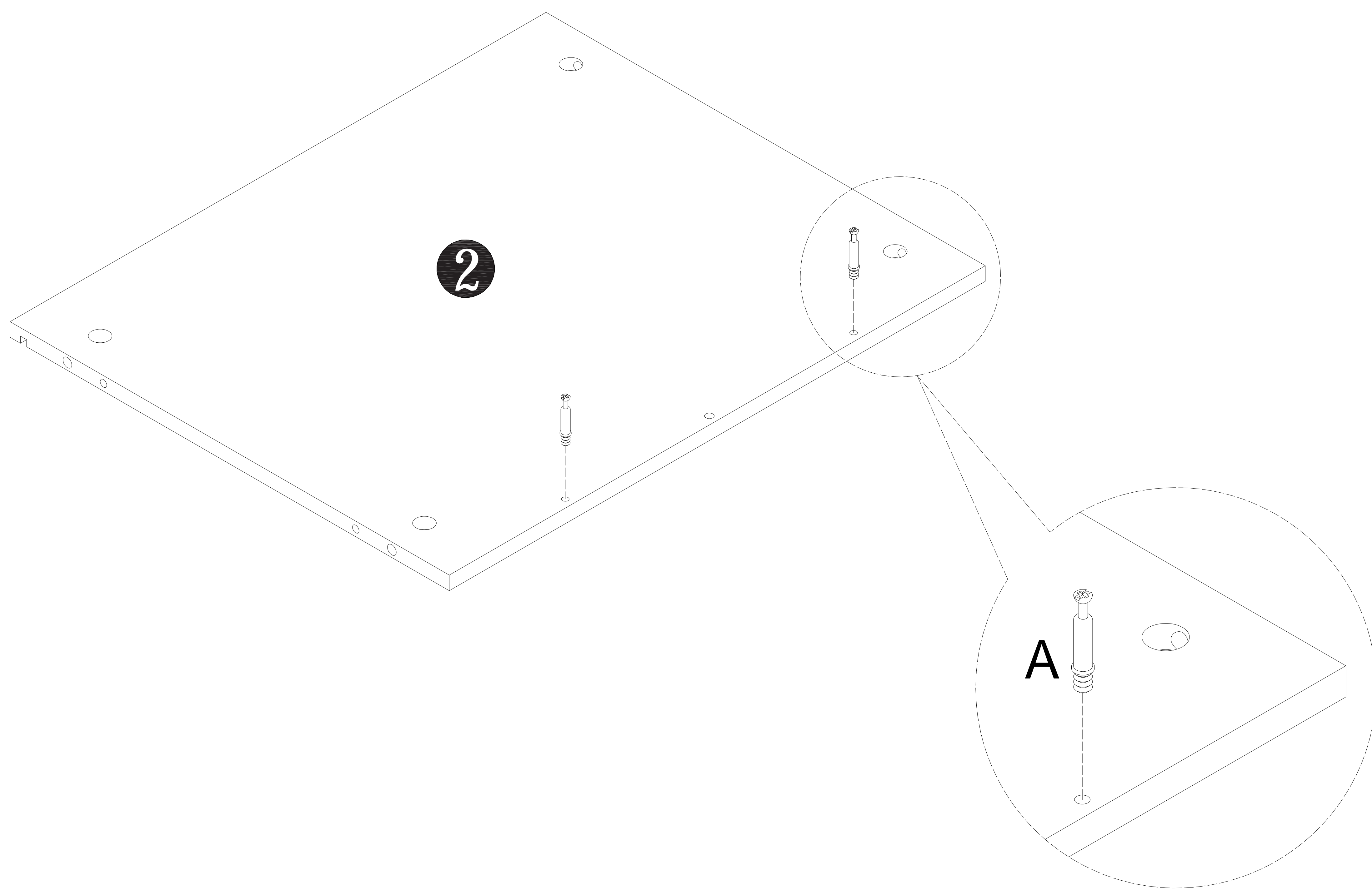
Step 6.

A

2PCS

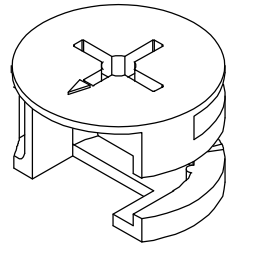

Step 7.

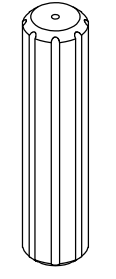
B

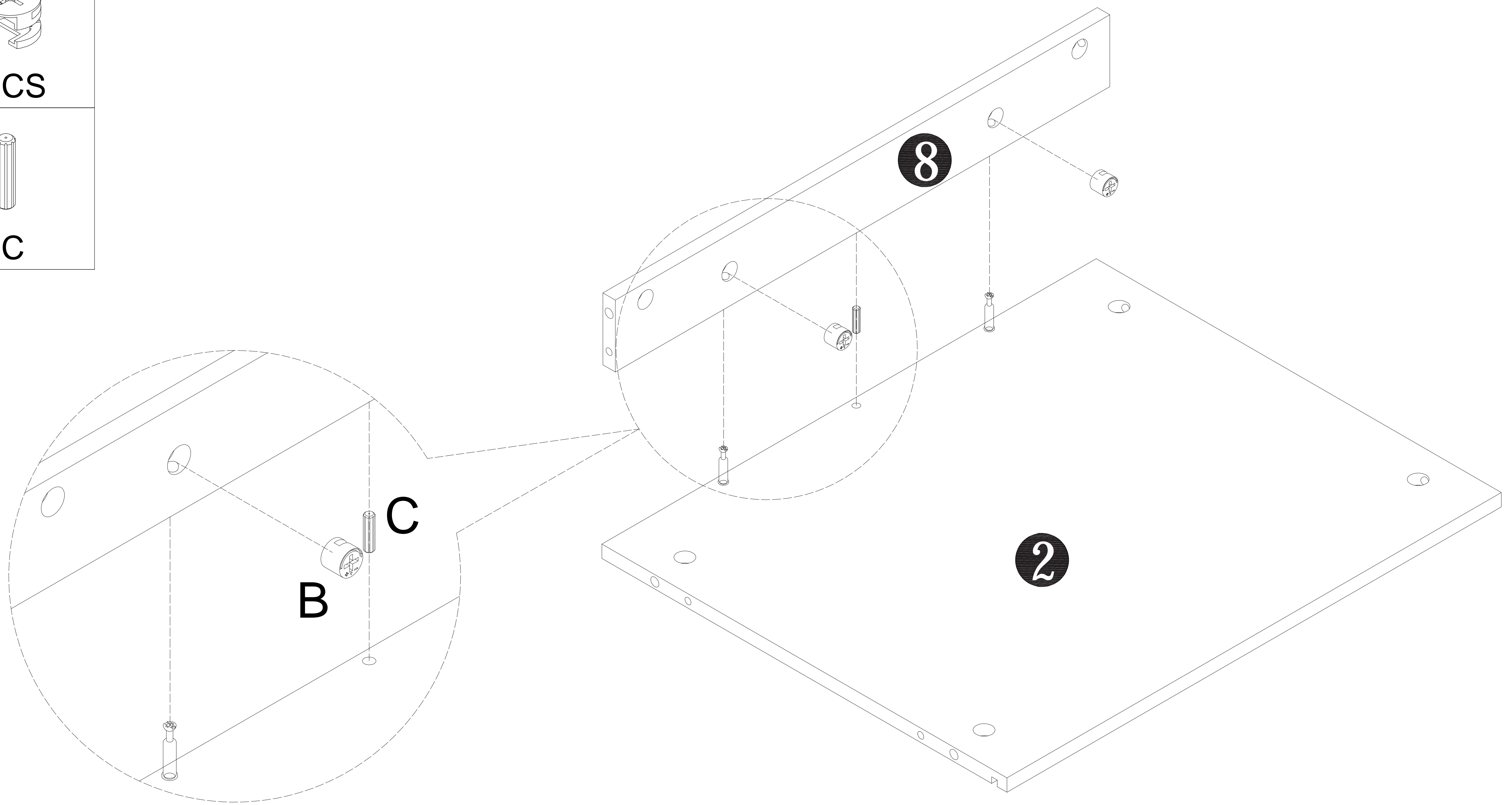
2PCS

C

1PC

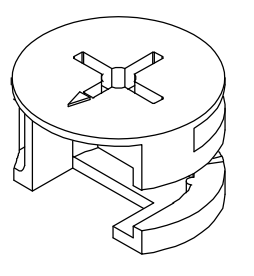

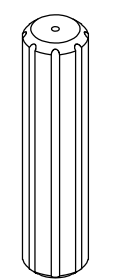
Step 8.

B

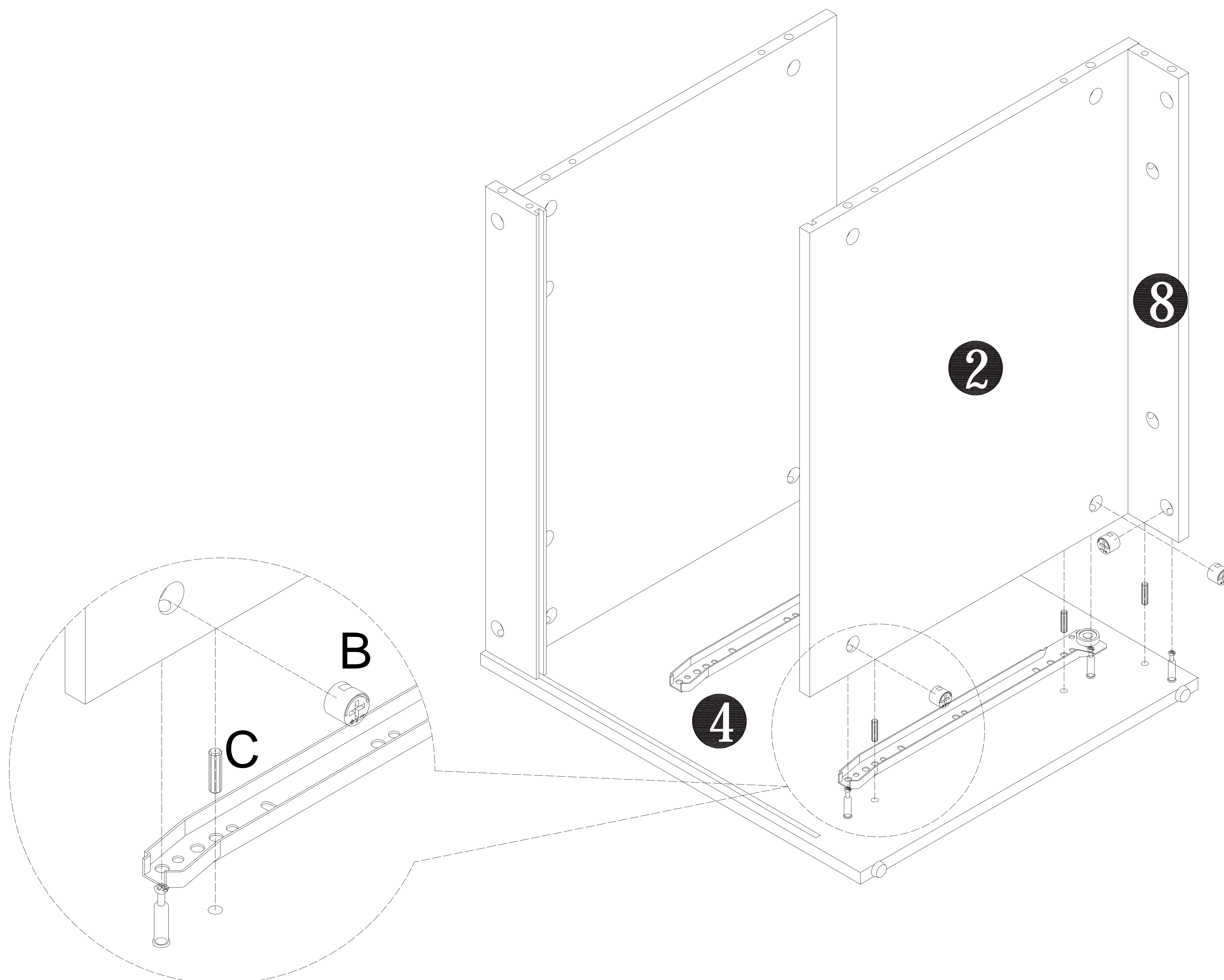
3PCS

C

3PCS

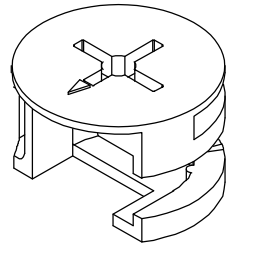
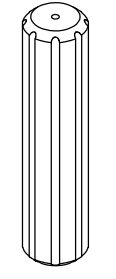

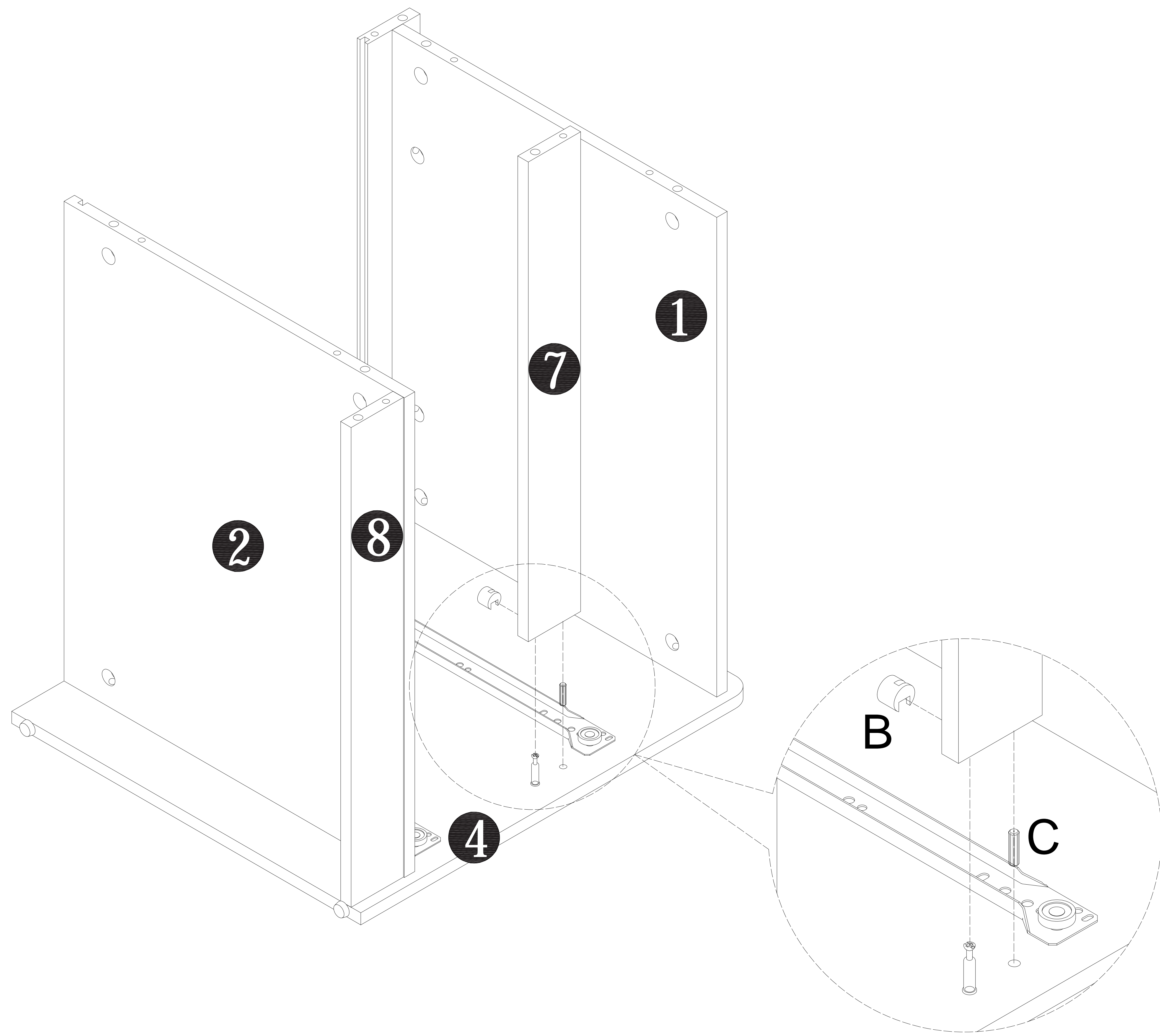
Step 9.

B	
	1PC
C	
	1PC



Step 10.

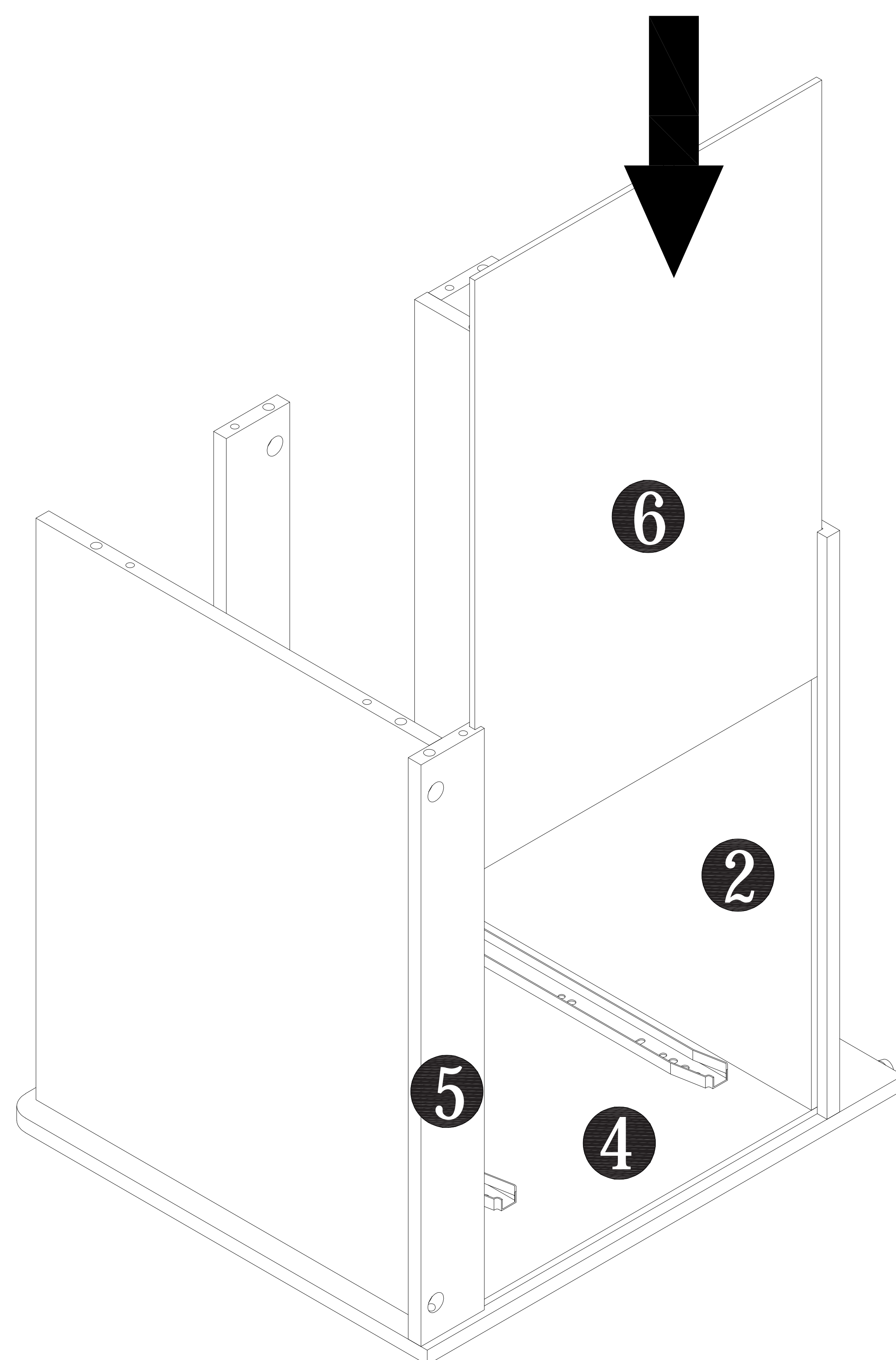

Step 11.

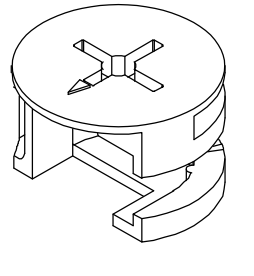
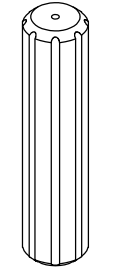
- B**

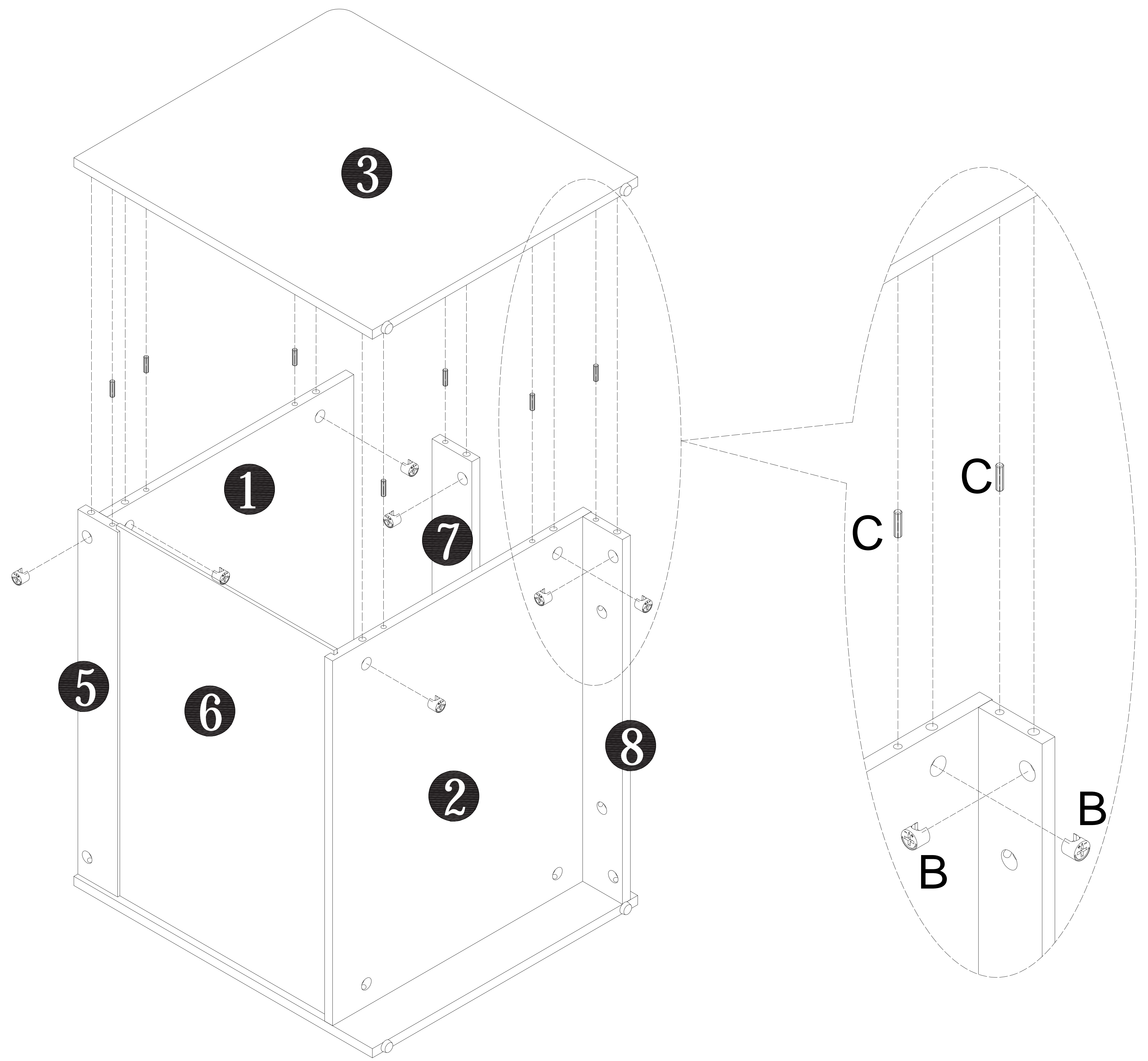
7PCS
- C**

7PCS

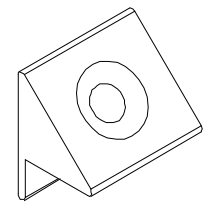
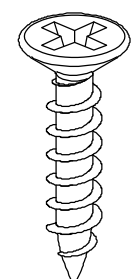

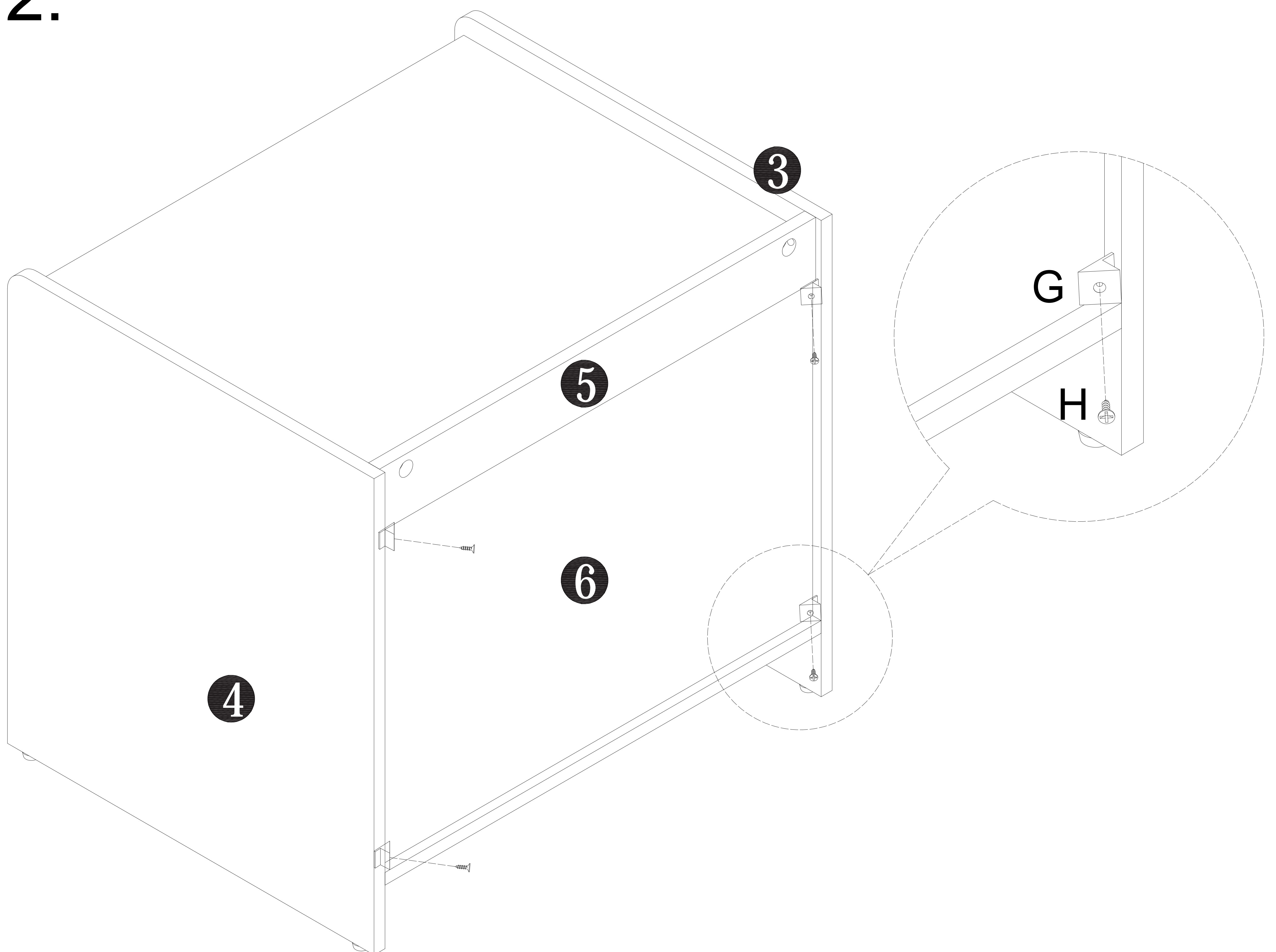
Step 12.

- G**

4PCS
- H**

4PCS

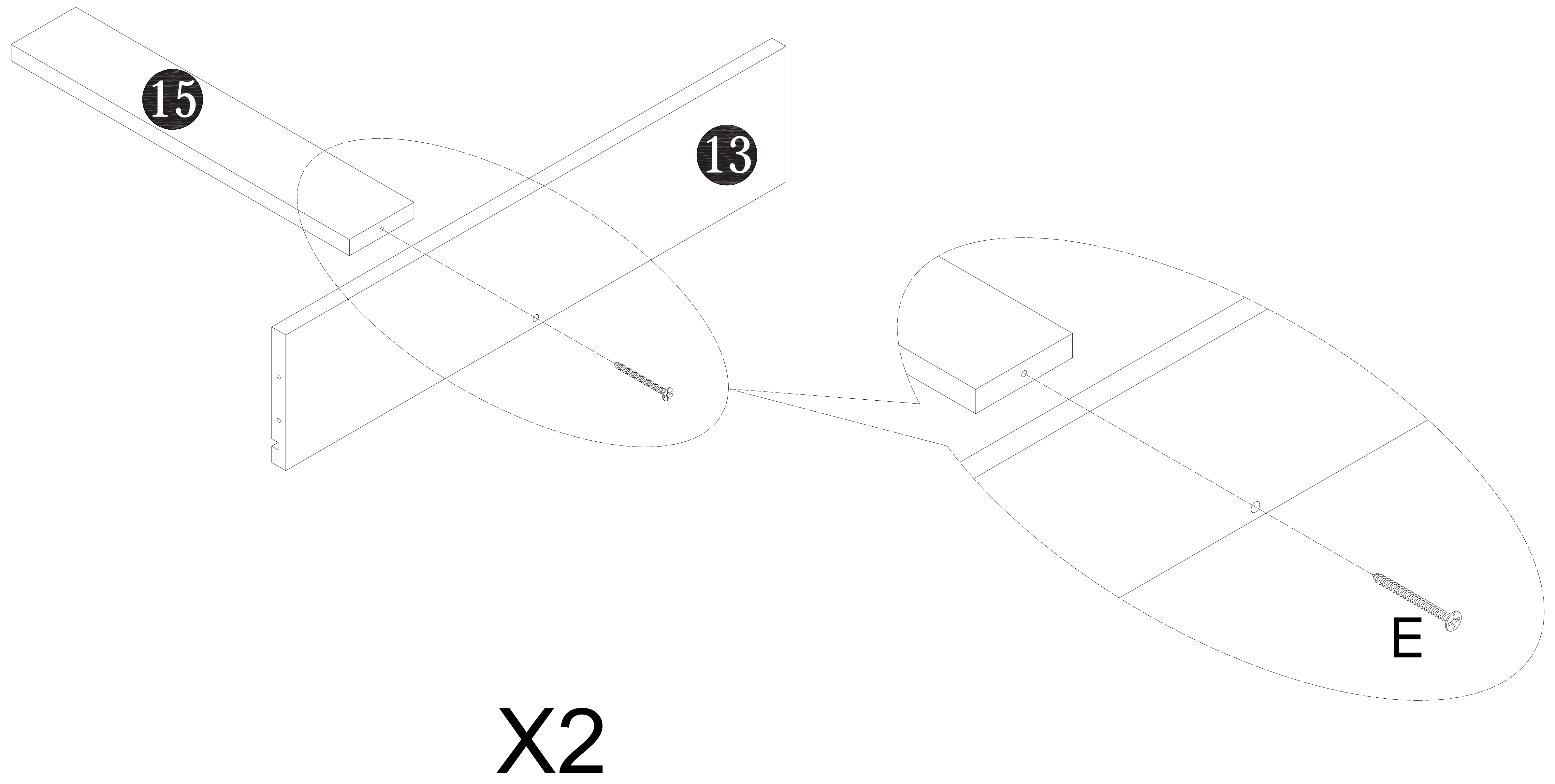
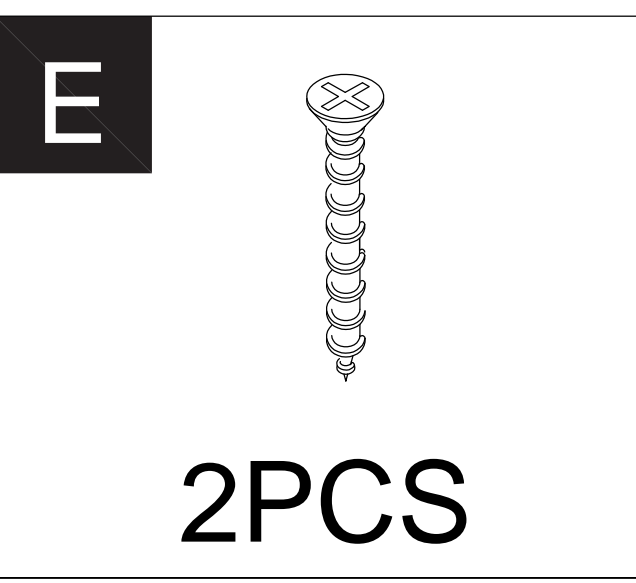

Step 13.

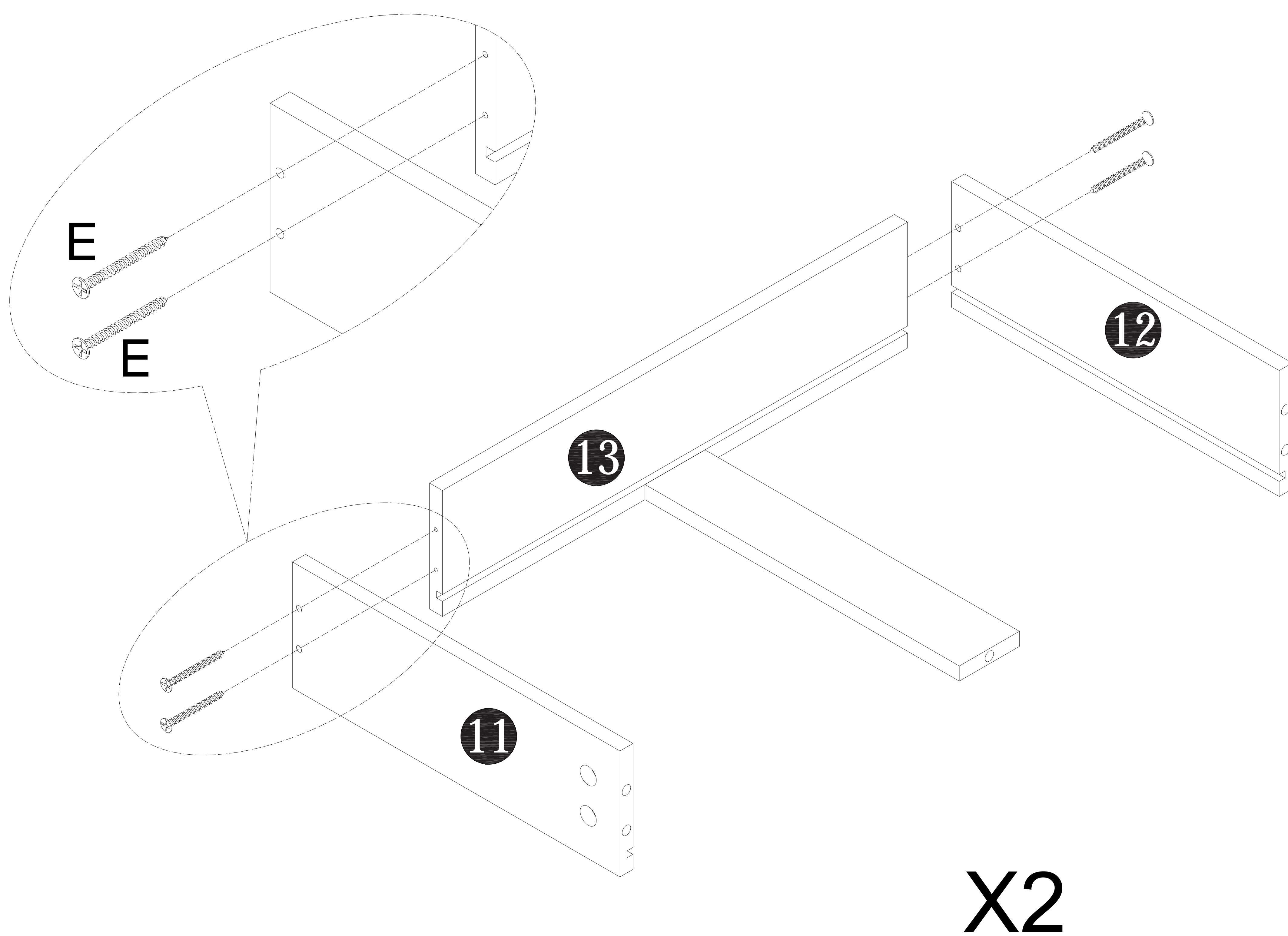
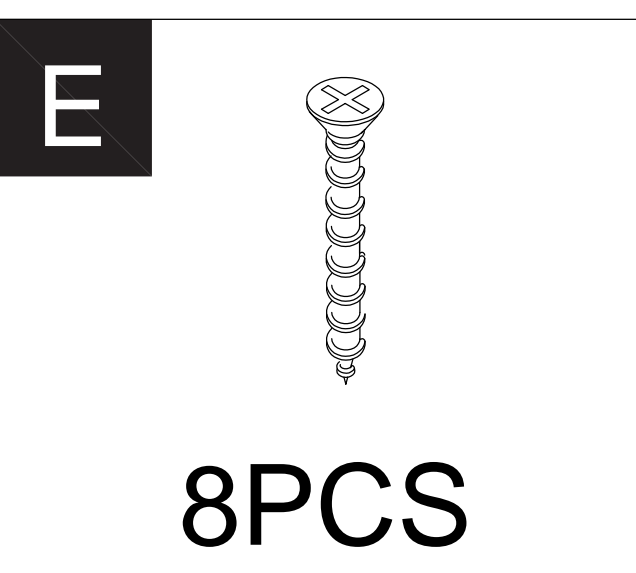

Step 14.



Step 15.

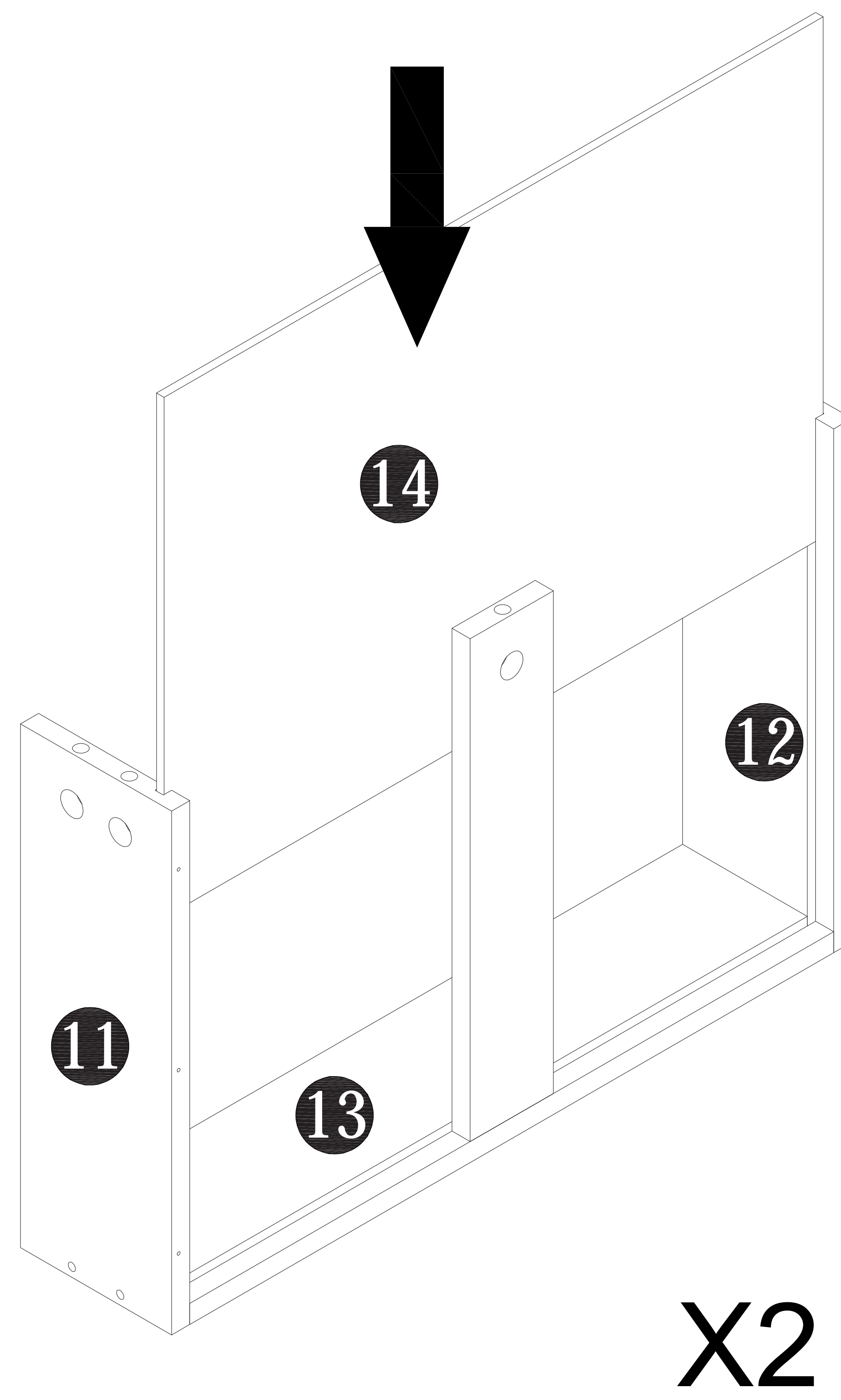

Step 16.

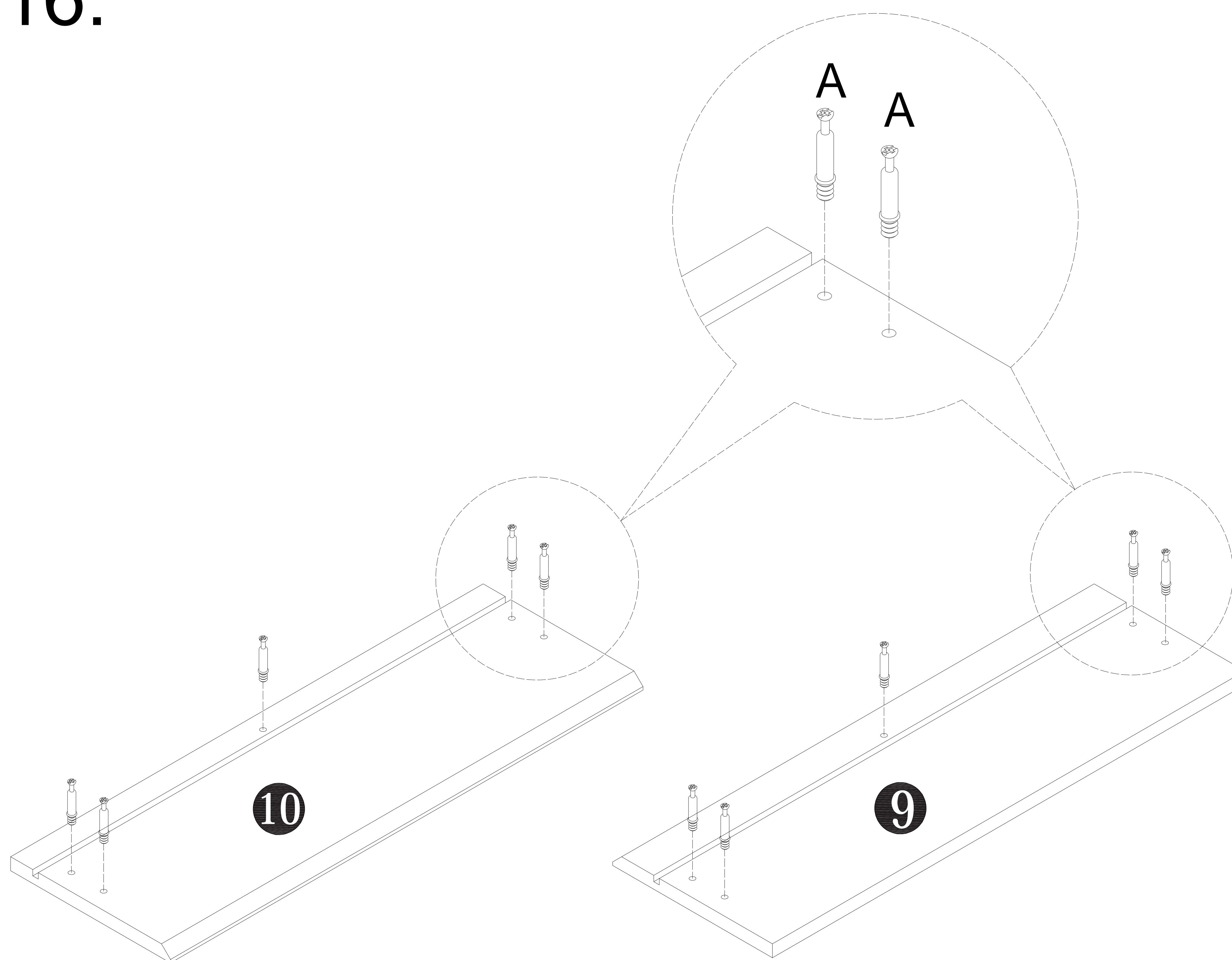
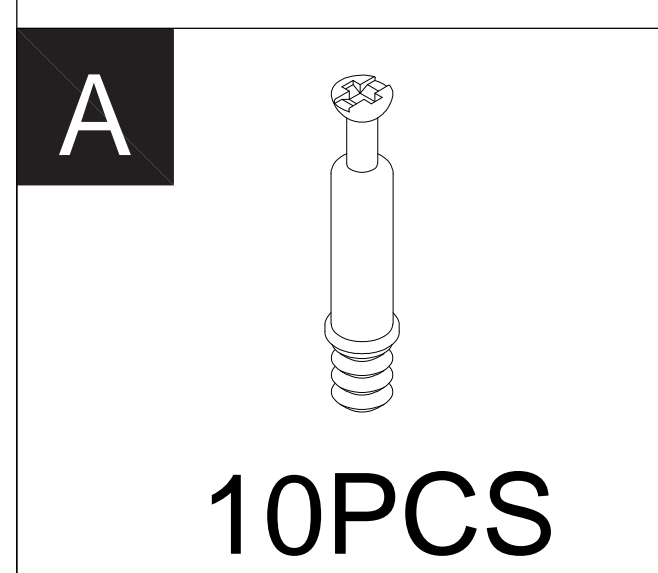

Step 17.

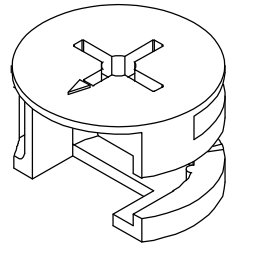
B

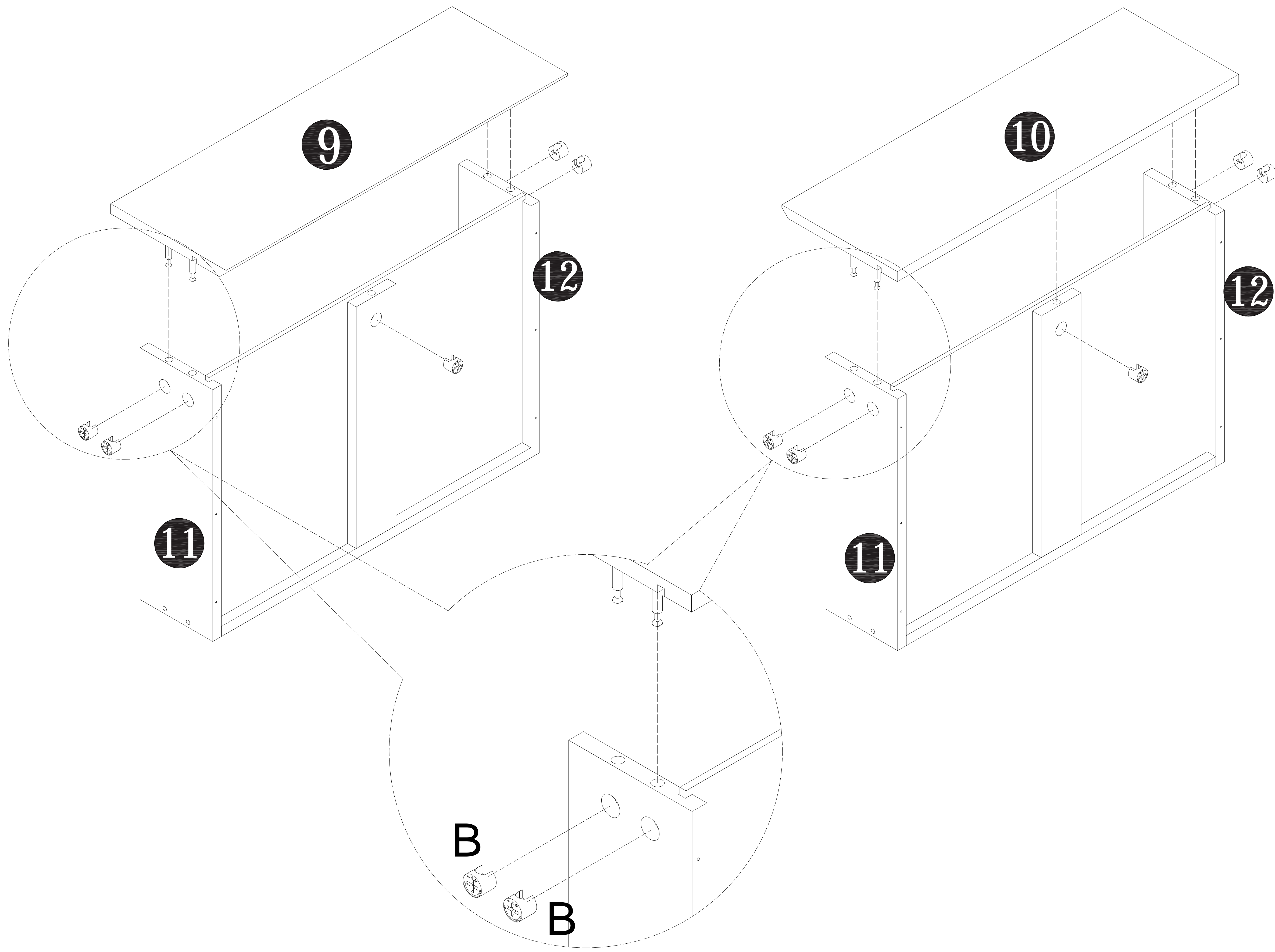
10PCS

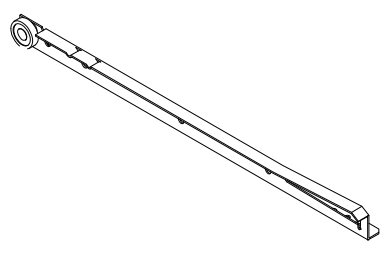

Step 18.

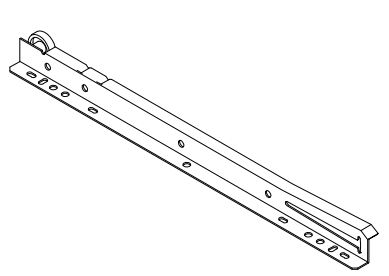
DL

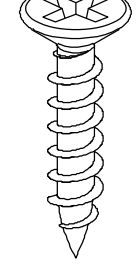
1PC

DR

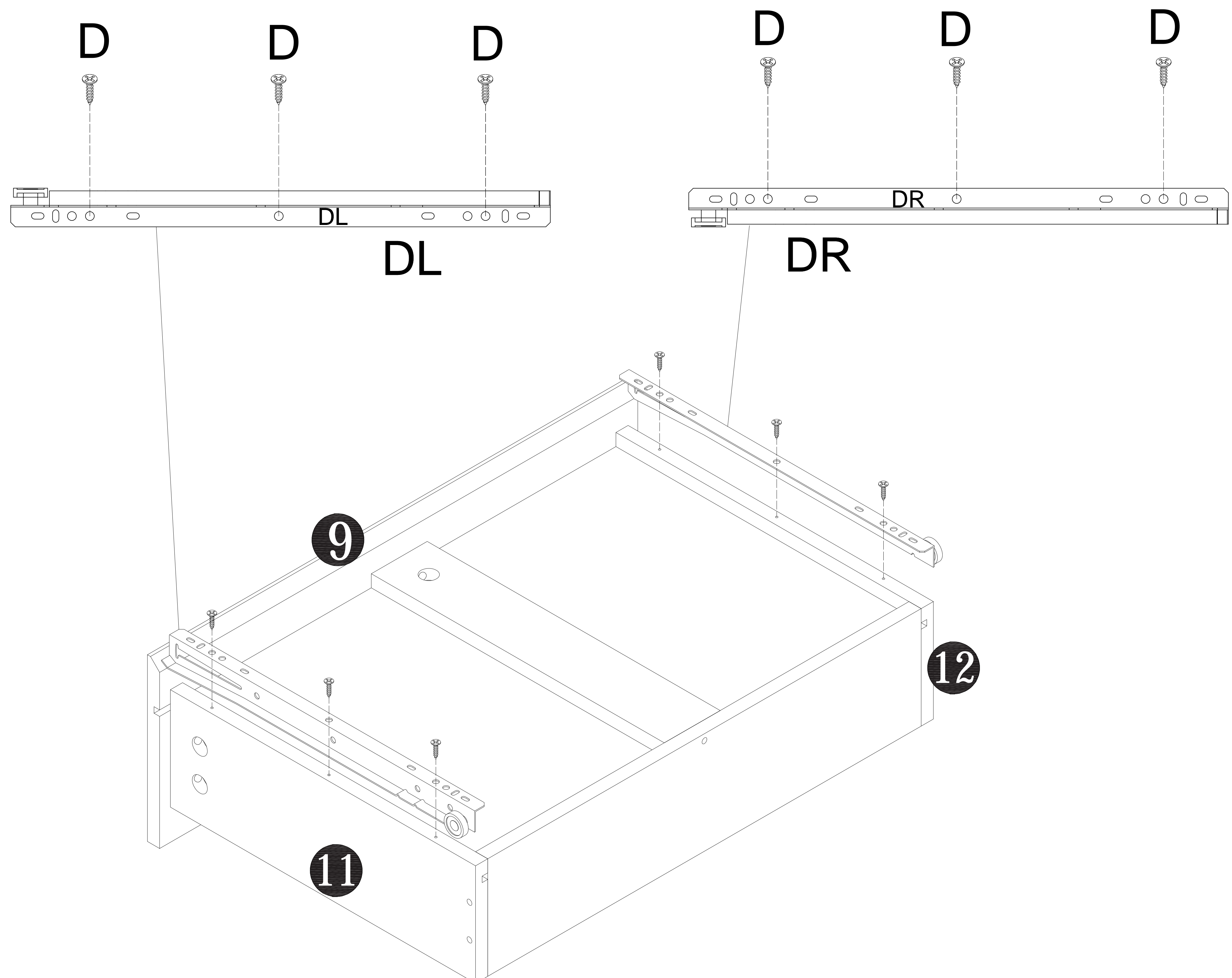
1PC

D

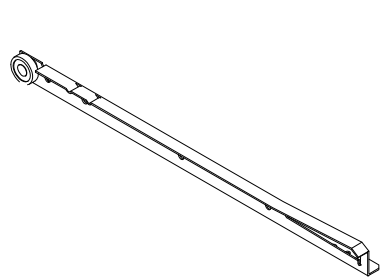
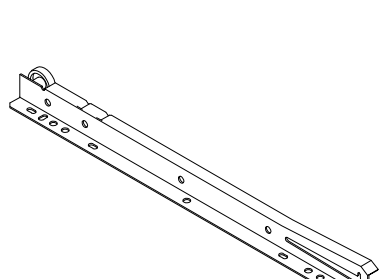
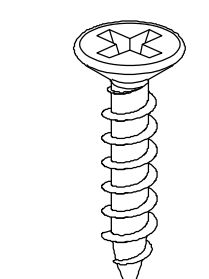
6PCS

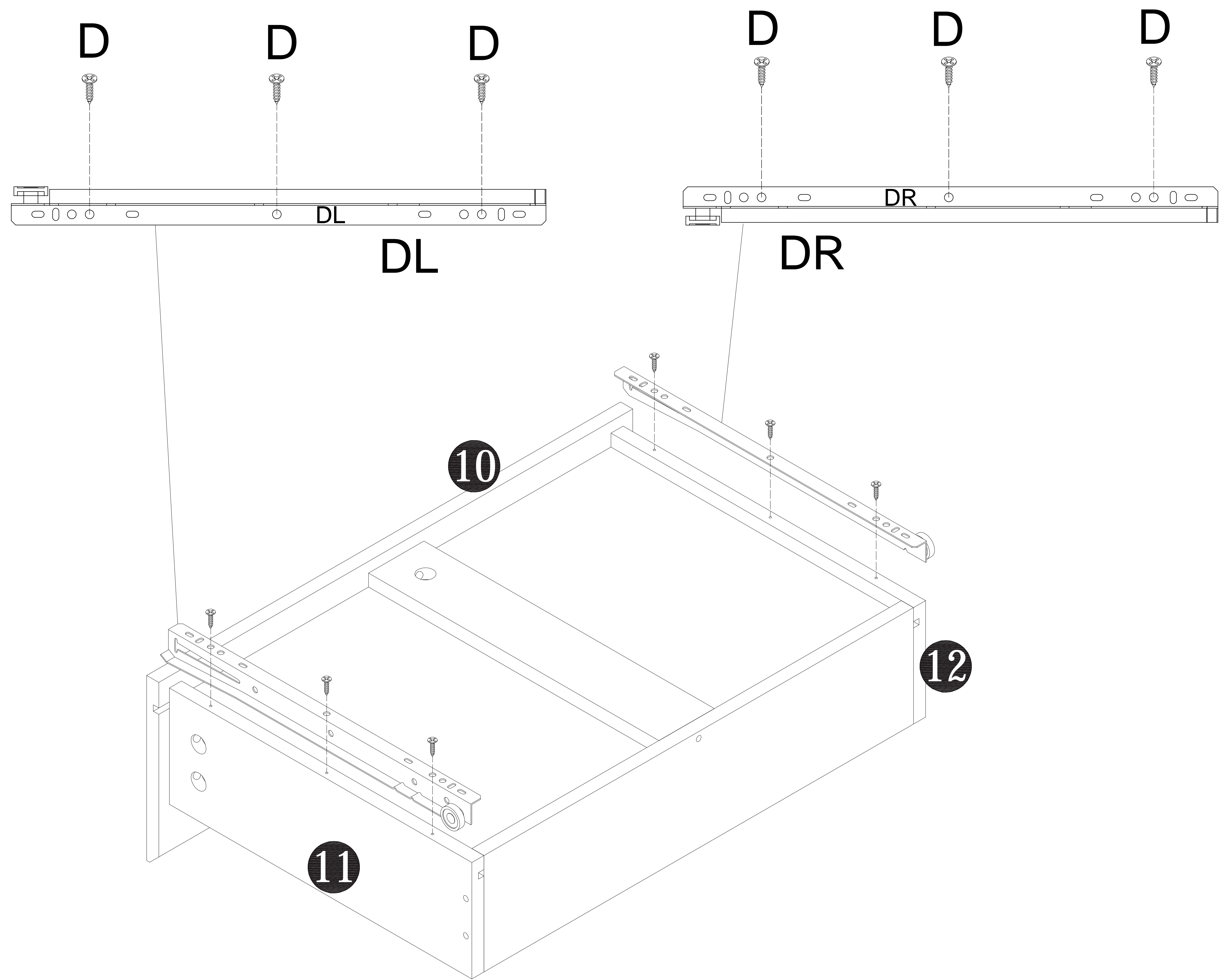

Step 19.

- DL**

1PC
- DR**

1PC
- D**

6PCS



Step 20.

