









Assembly Instruction

ITEM:SF-DT066

Parts List			
Item	Description	Part	Qty
Part 1	Table Top		1
Part 2	Table Bases		3
Part 3	Triangular Bracket		2

Hardware List			
Item	Description	Part	Qty
A	Allen Wrench		1
B	Bolt		6
C	Spring washer(ø8)		6
D	Metalwasher		6
E	Suction Lock		3

Note:

- 1、 Verify all parts before installation
- 2、 Always lay protective cushioning on the floor before assembly

STEP 1

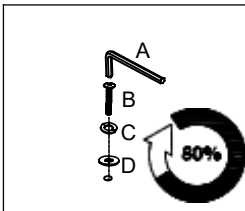

Attach **Part 3** to **Part 2** using screw **B** with **C** and **D** at the top and bottom.

Tighten the screws to about 80%. Do not fully tighten them yet.

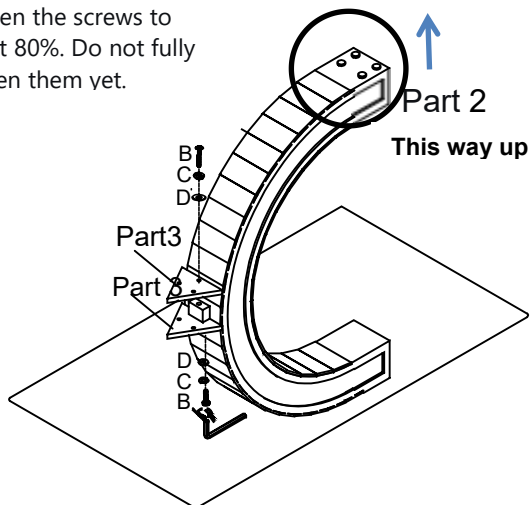

Ensure correct orientation to avoid reinstallation.

STEP 2

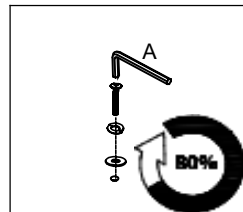

Insert the other two **Part 2** pieces into the previously installed **Part 3** assemblies, & secure them with 2 screws **B**, **C**, and flat washers **D**

Tighten the screws to about 80%

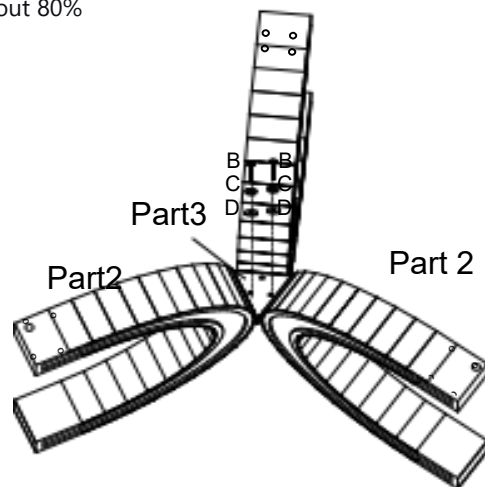

Assembly Instruction

ITEM:SF-DT066

STEP 3

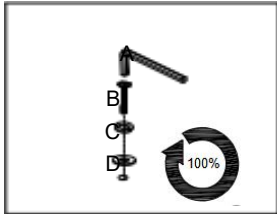

Rotate the assembled unit 180 degrees, then secure it with two screws B, C, and D.

Fully tighten all screws

Rotate with this side up

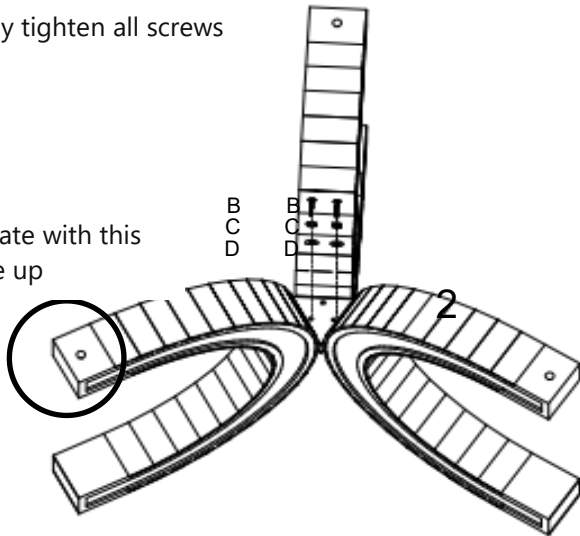

STEP 4

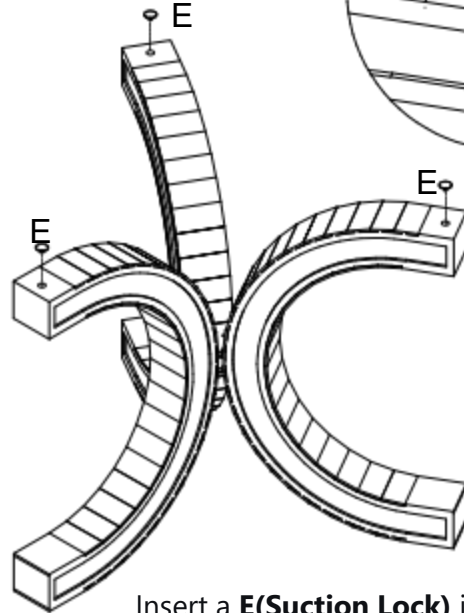
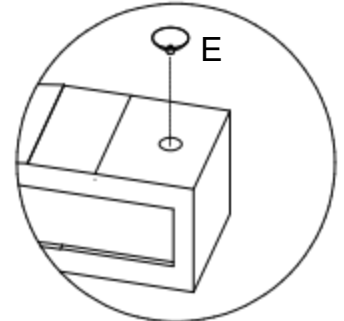

Insert a **E(Suction Lock)** into each of the three table legs

STEP 5

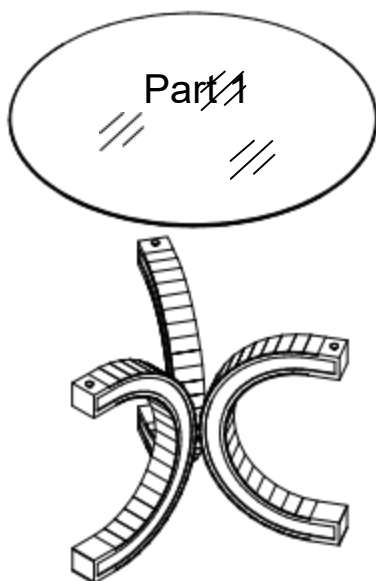

Align the center point and place the tabletop onto the base assembly.

STEP 6

Gently rock the table to ensure it is stable and secure.

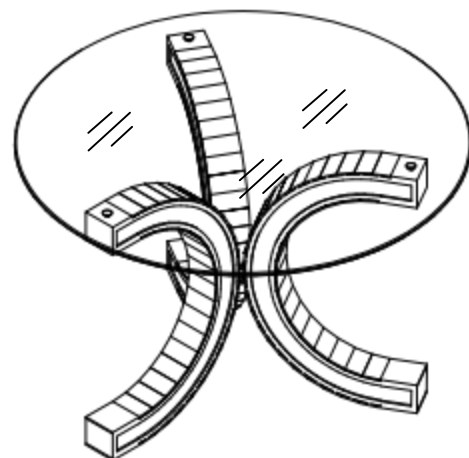

△When moving the table, always lift the base assembly with two people.

Do not drag the table or lift it by the tabletop.