

ASSEMBLY INSTRUCTION

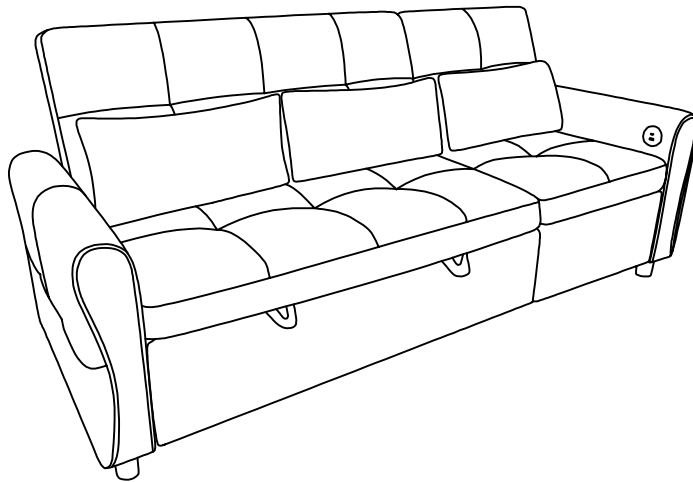

VERSION 1

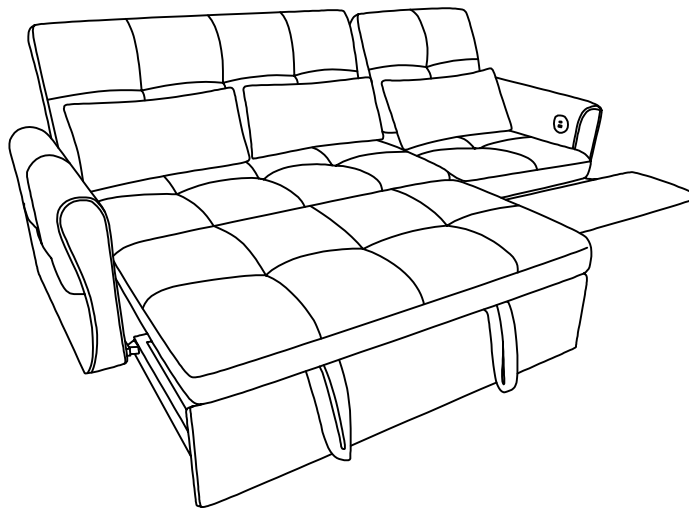



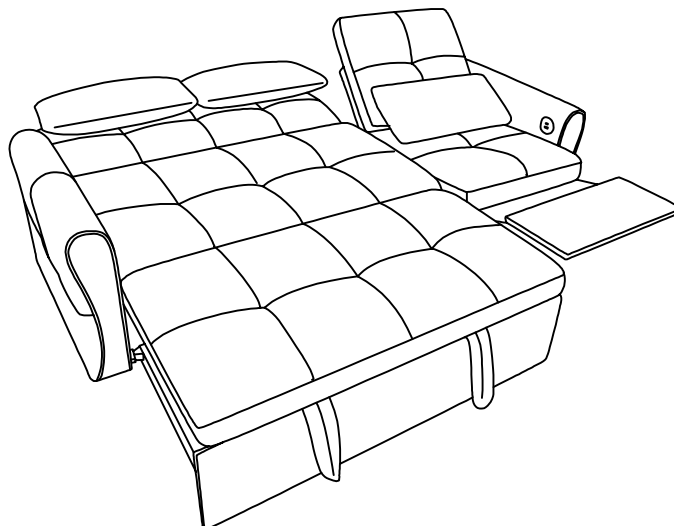





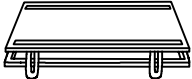
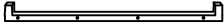

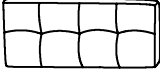

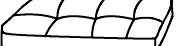
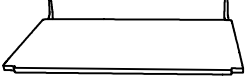

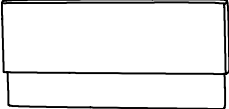



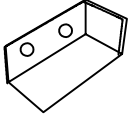
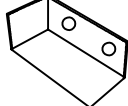





VERSION 2





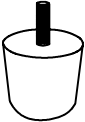

VERSION 3

COMPONENT LIST

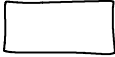

NO.	DRAWING	QTY	DESCRIPTION
A		1	Sofa bed frame
C		1	Sofa bed front supporting block
D		1	Sofa bed front baffle
E		1	Two-seat backrest cushion
G		1	Two-seat seat cushion
I		1	Sofa bed seat cushion
BL		1	Two-seat frame
B		1	Two-seat rear baffle
CL		1	Two-seat backrest
X		1	Power supply
①		2	Hinges
②		4	Metal brackets
③-L		1	Left wheel retainer
③-R		1	Right wheel retainer

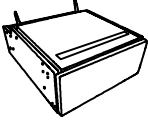
NO.	DRAWING	QTY	DESCRIPTION
④		8	Screws M6*15MM
⑤		24	Screws M6*20MM
⑥		7	Screws M6*30MM
⑦		4	Screws M6*55MM
⑧		4	Screws M8*60MM
⑨		24	Screws M5*15MM
⑩		1	Wrench M6
⑪		1	Wrench M8
⑫		1	Cross wrench
⑬		2	Male conical connectors
⑭		2	Female conical connectors
⑮		6	Wheels
Z		4	Legs
Y		4	Gaskets

COMPONENT LIST

NO.	DRAWING	QTY	DESCRIPTION
ⓐ		3	Throw pillows
ⓑ		1	Single seat frame
ⓒ		1	Single backrest cushion
ⓓ		1	Single seat rear baffle
ⓔ		1	Single seat backrest

COMPONENT LIST

NO.	DRAWING	QTY	DESCRIPTION
ⓕ		1	Left armrest
ⓖ		1	Right armrest

* Take out the

- | | | | | | | | | | | |
|----|---|-----|-----|---|---|---|---|---|---|---|
| CL | B | I | BL | D | C | A | G | E | Y | Z |
| ① | ② | ③-L | ③-R | ④ | ⑤ | ⑥ | ⑦ | ⑧ | ⑨ | |
| ⑩ | ⑪ | ⑫ | ⑬ | ⑭ | ⑮ | | | | | |

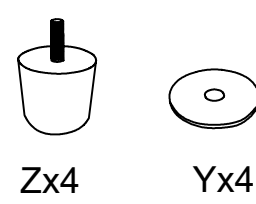
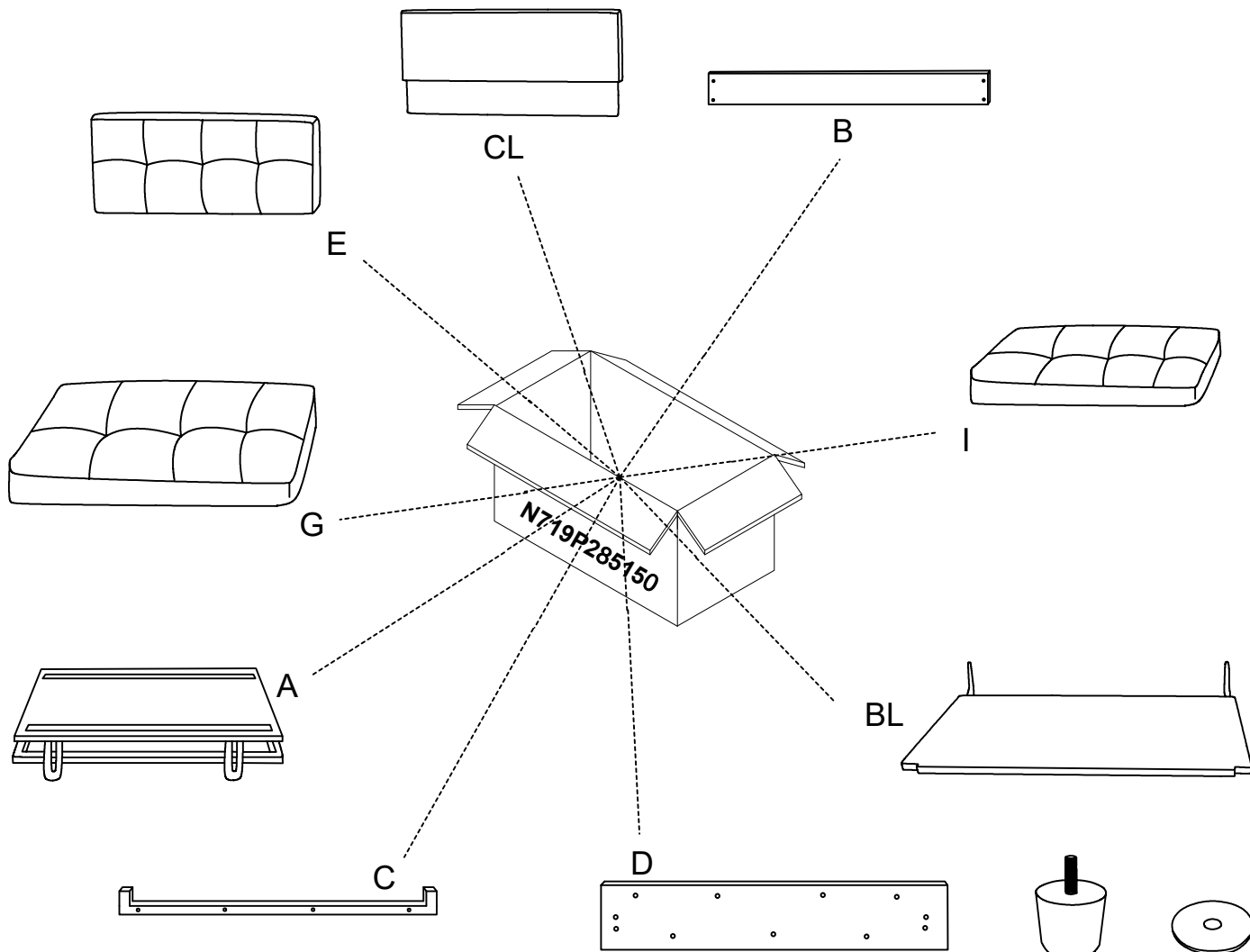

- ① x2pcs ② x4pcs ③-L x1 pc ③-R x1 pc

- ④ x8pcs ⑤ x24pcs ⑥ x7pcs ⑦ x4pcs ⑧ x4pcs
M6*15MM M6*20MM M6*30MM M6*55MM M8*60MM

- ⑨ x24pcs ⑩ x1 pc ⑪ x1 pc ⑫ x1 pc x
- M5*15MM

- ⑬ x2pcs ⑭ x2pcs ⑮ x6pcs

* Take out the CR J*3 H BR F

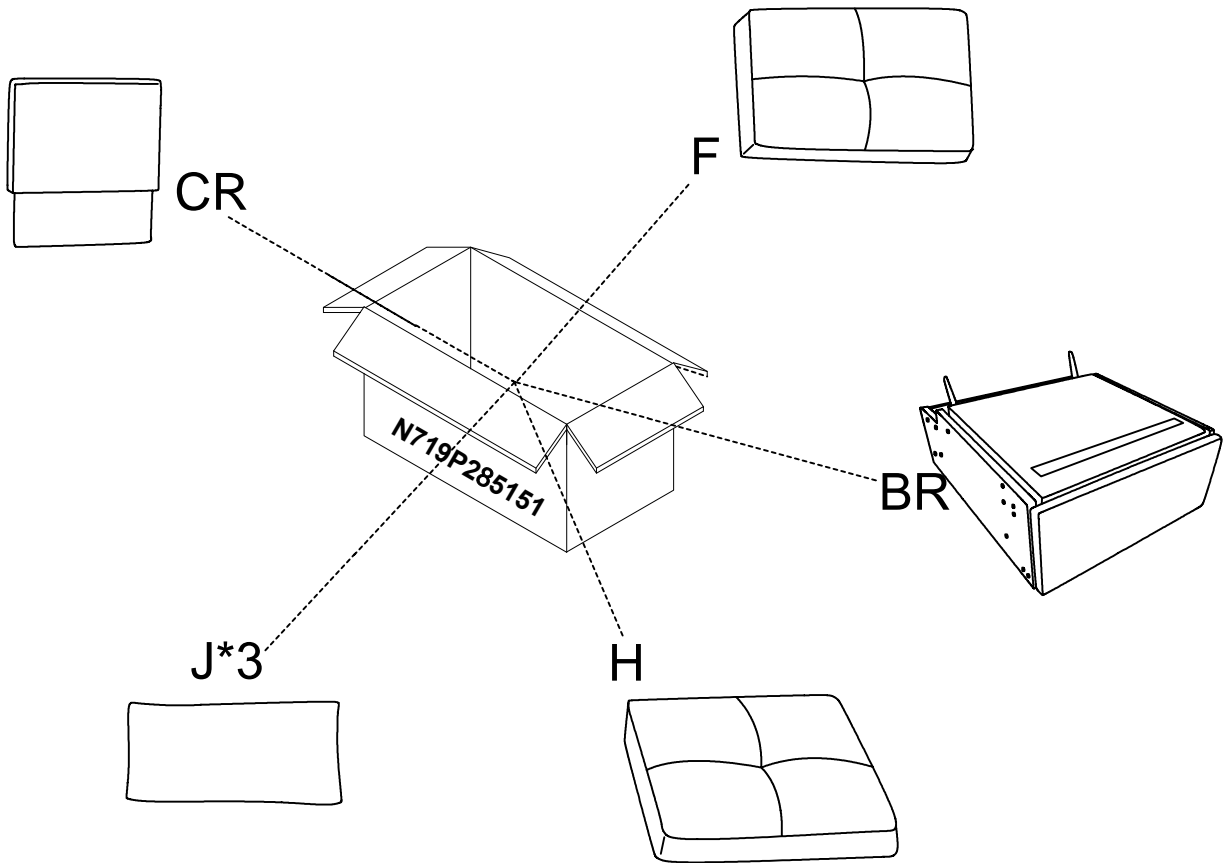



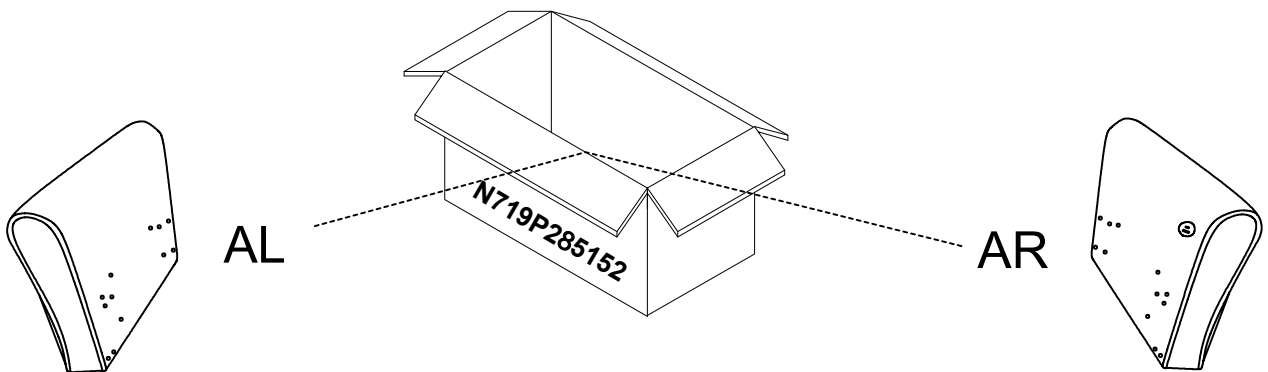



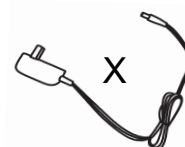
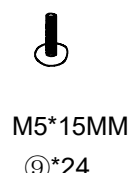
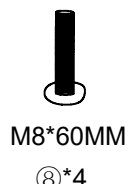
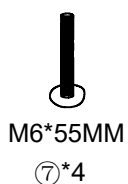
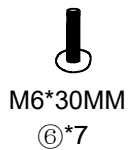
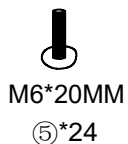
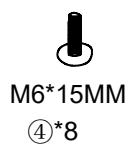
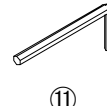
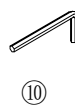
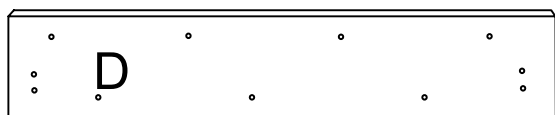
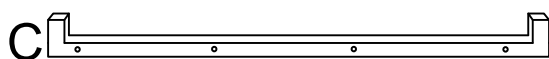
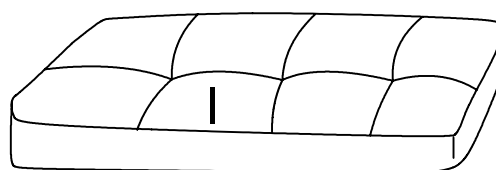
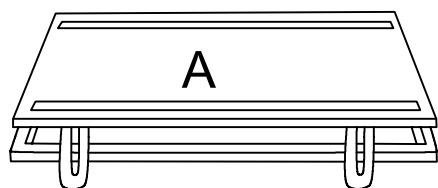
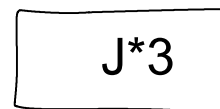
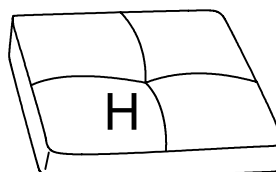
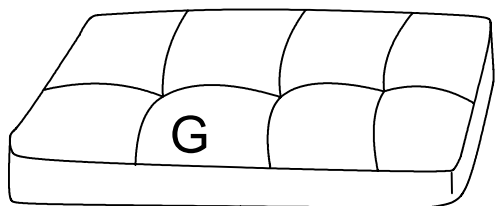
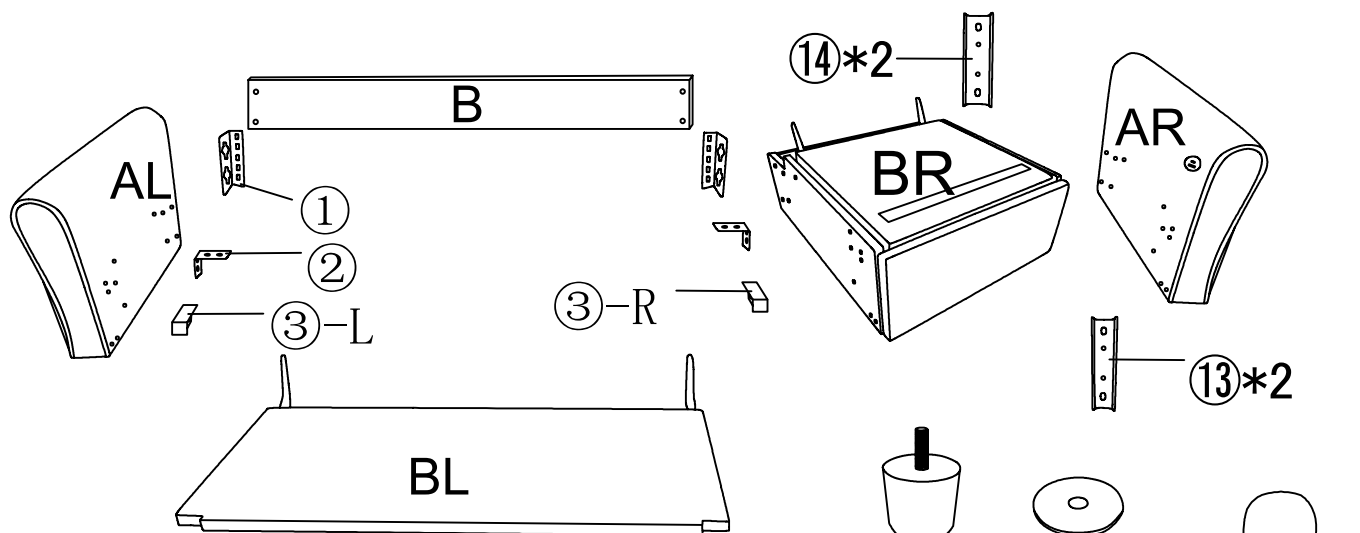
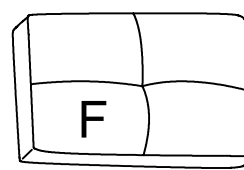
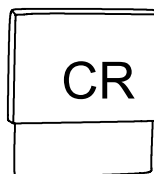
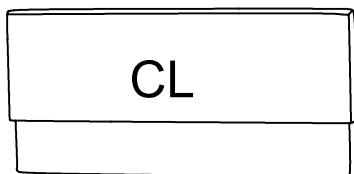
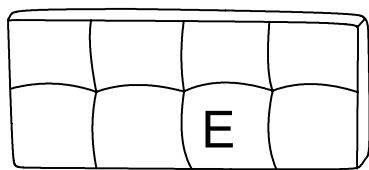



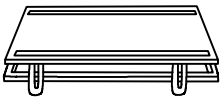
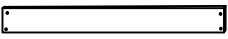
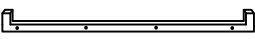
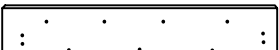
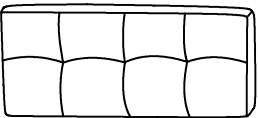
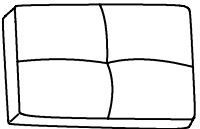
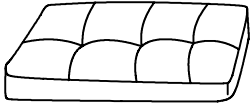

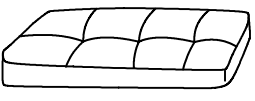
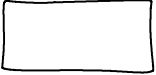
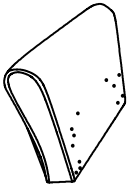
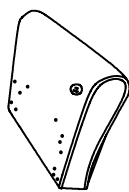
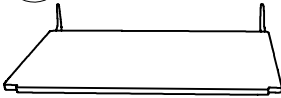
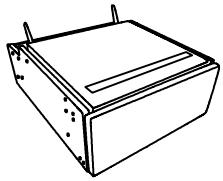
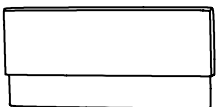
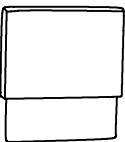

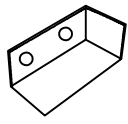
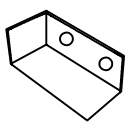



* Take out the AL AR



PARTS LIST

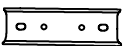

PARTS LIST

<p>(A)</p> 	<p>(B)</p> 	<p>(C)</p> 	<p>(D)</p> 	<p>(E)</p> 
<p>Sofa bed frame x 1 pc</p>	<p>Two-seat rear baffle x 1 pc</p>	<p>Sofa bed front supporting block x 1 pc</p>	<p>Sofa bed front baffle x 1 pc</p>	<p>Two-seat backrest cushion x 1 pc</p>
<p>(F)</p> 	<p>(G)</p> 	<p>(H)</p> 	<p>(I)</p> 	<p>(J)</p> 
<p>Single backrest cushion x 1 pc</p>	<p>Two-seat seat cushion x 1 pc</p>	<p>Single seat cushion x 1 pc</p>	<p>Sofa bed seat cushion x 1 pc</p>	<p>Throw pillows x 3 pcs</p>
<p>(AL)</p> 	<p>(AR)</p> 	<p>(BL)</p> 	<p>(BR)</p> 	<p>(CL)</p> 
<p>Left armrest x 1 pc</p>	<p>Right armrest x 1 pc</p>	<p>Two-seat frame x 1 pc</p>	<p>Single seat frame x 1 pc</p>	<p>Two-seat backrest x 1 pc</p>
<p>(CR)</p> 	<p>(1)</p> 	<p>(2)</p> 	<p>(3-L)</p> 	<p>(3-R)</p> 
<p>Single seat backrest x 1 pc</p>	<p>Hinges x 2 pcs</p>	<p>Metal brackets x 4 pcs</p>	<p>Left wheel retainer x 1 pc</p>	<p>Right wheel retainer x 1 pc</p>
<p>(4)</p> 	<p>(5)</p> 	<p>(6)</p> 	<p>(7)</p> 	<p>(8)</p> 
<p>Screws M6*15MM x 8 pcs</p>	<p>Screws M6*20MM x 24 pcs</p>	<p>Screws M6*30MM x 7 pcs</p>	<p>Screws M6*55MM x 4 pcs</p>	<p>Screws M8*60MM x 4 pcs</p>
<p>(9)</p> 	<p>(10)</p> 	<p>(11)</p> 	<p>(12)</p> 	<p>(13)</p> 
<p>Screws M5*15MM x 24 pcs</p>	<p>Wrench M6 x 1 pc</p>	<p>Wrench M8 x 1 pc</p>	<p>Cross wrench x 1 pc</p>	<p>Male conical connectors x 2 pcs</p>
<p>(14)</p> 	<p>(15)</p> 	<p>(Z)</p> 	<p>(Y)</p> 	<p>(X)</p> 
<p>Female conical connectors x 2 pcs</p>	<p>Wheels x 6 pcs</p>	<p>Legs x 4 pcs</p>	<p>Gaskets x 4 pcs</p>	<p>Power supply x 1 pc</p>

STEP 1:

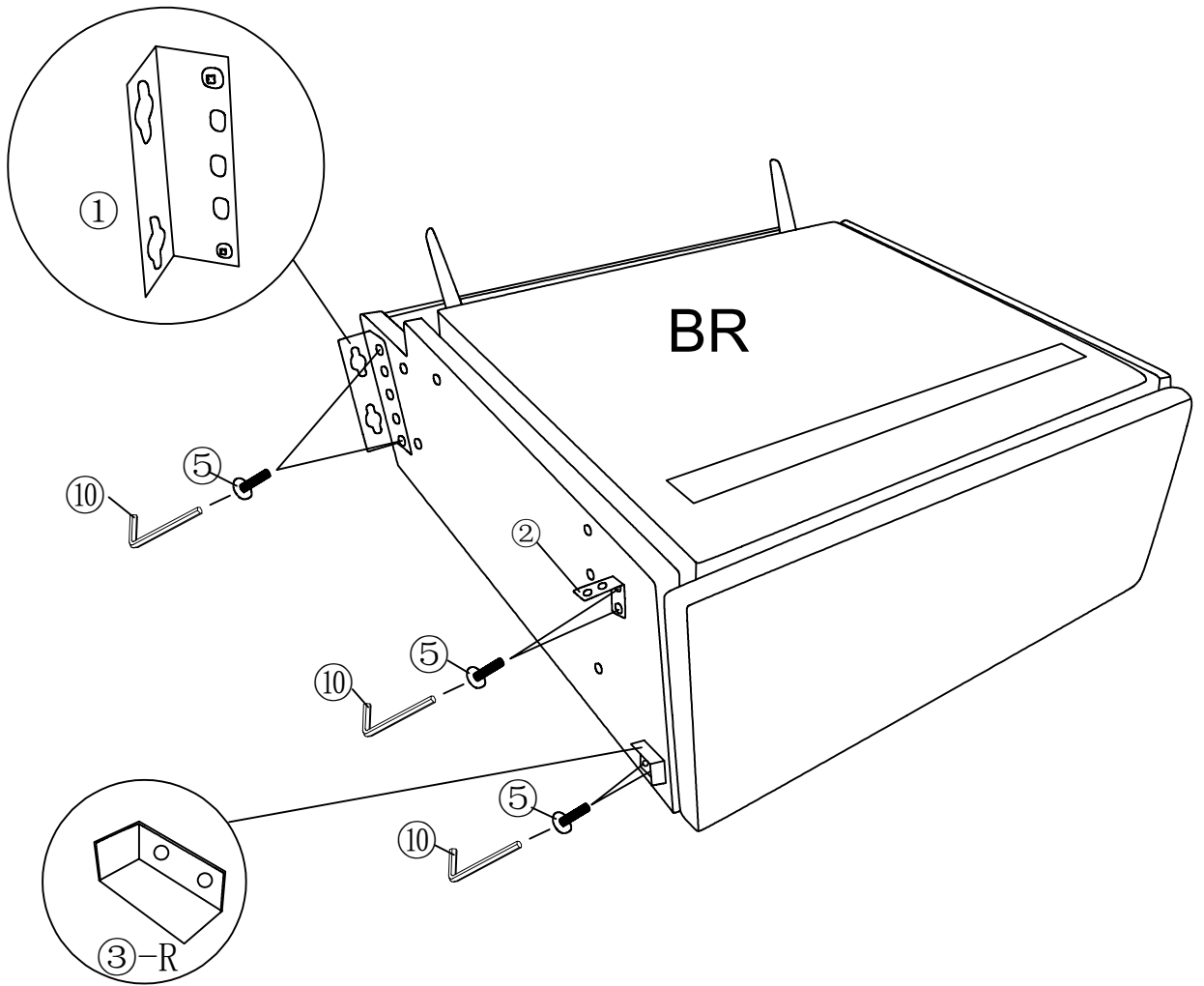

STEP 2:

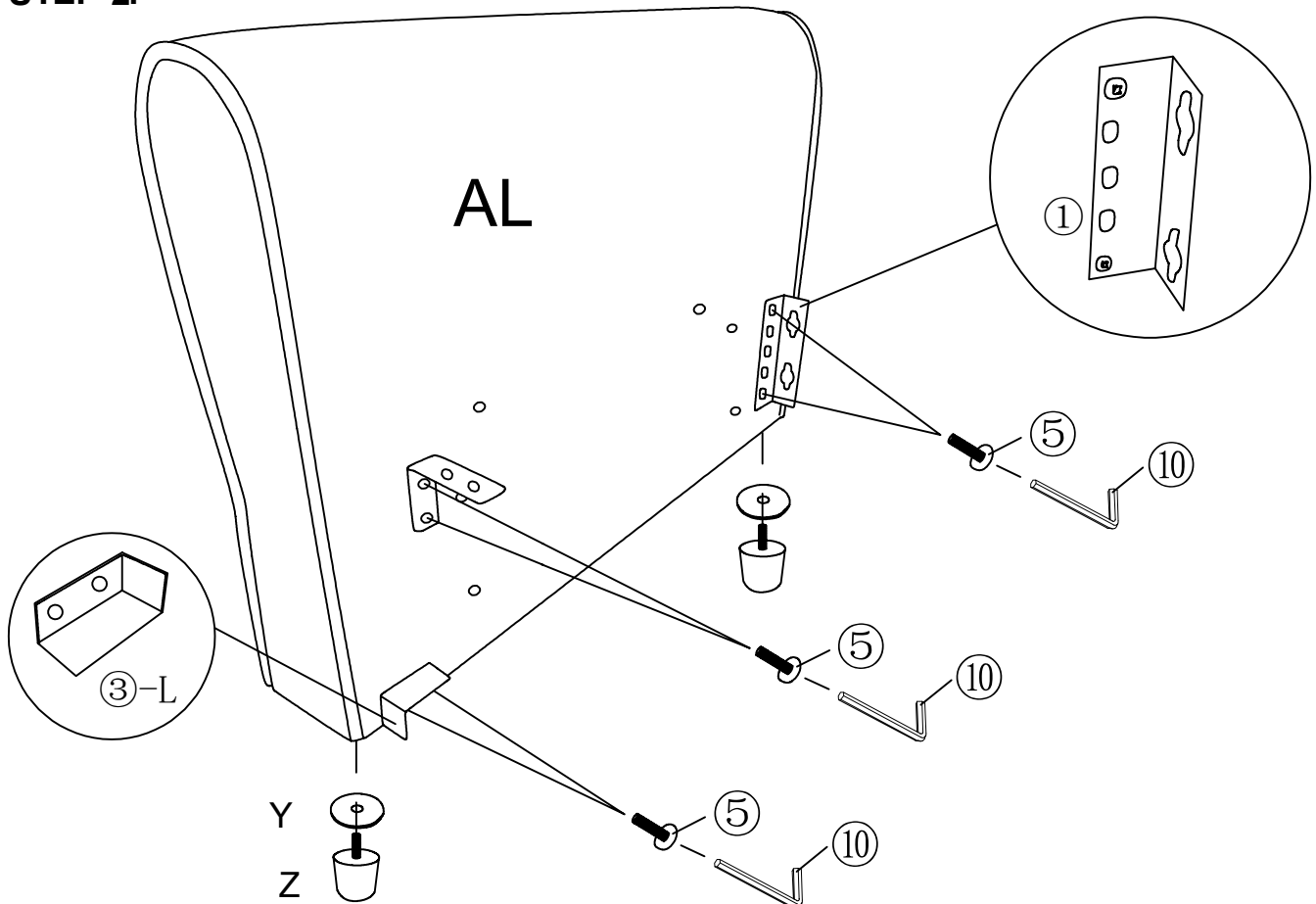

STEP 3:

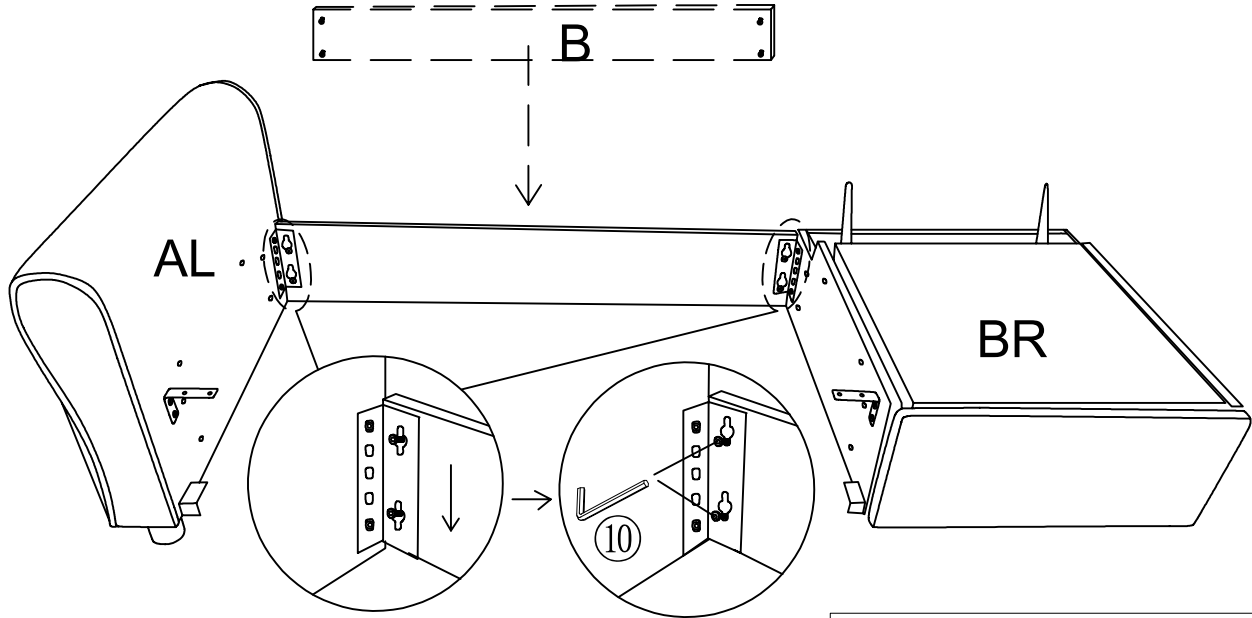

NOTE: ASSEMBLE FOR 2 FRAMES

STEP 4:

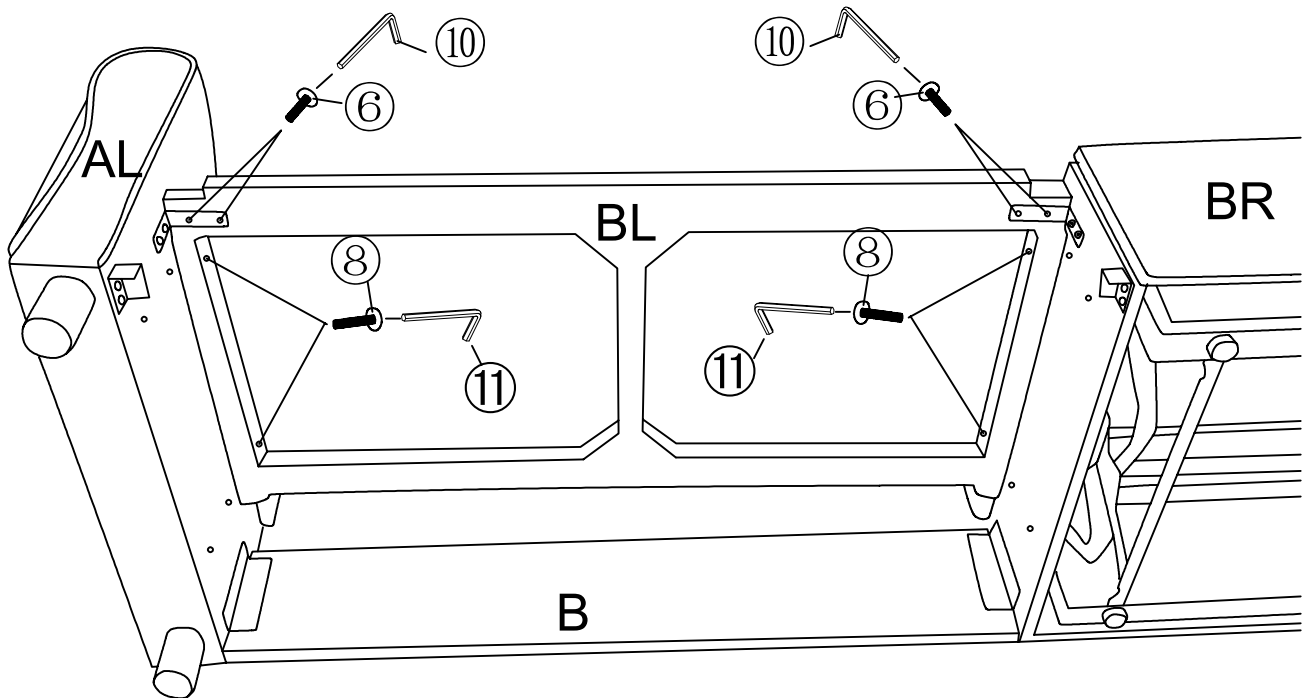

Step-by-Step Instructions :

1. Tighten Screw to 80%: Apply 80% of the to screws .
2. Tighten Screw to 100%: Fully tighten Screw to 100% .
3. Final Tightening of Screw to 100%: Return to Screw and complete its tightening to 100% .

STEP 5:

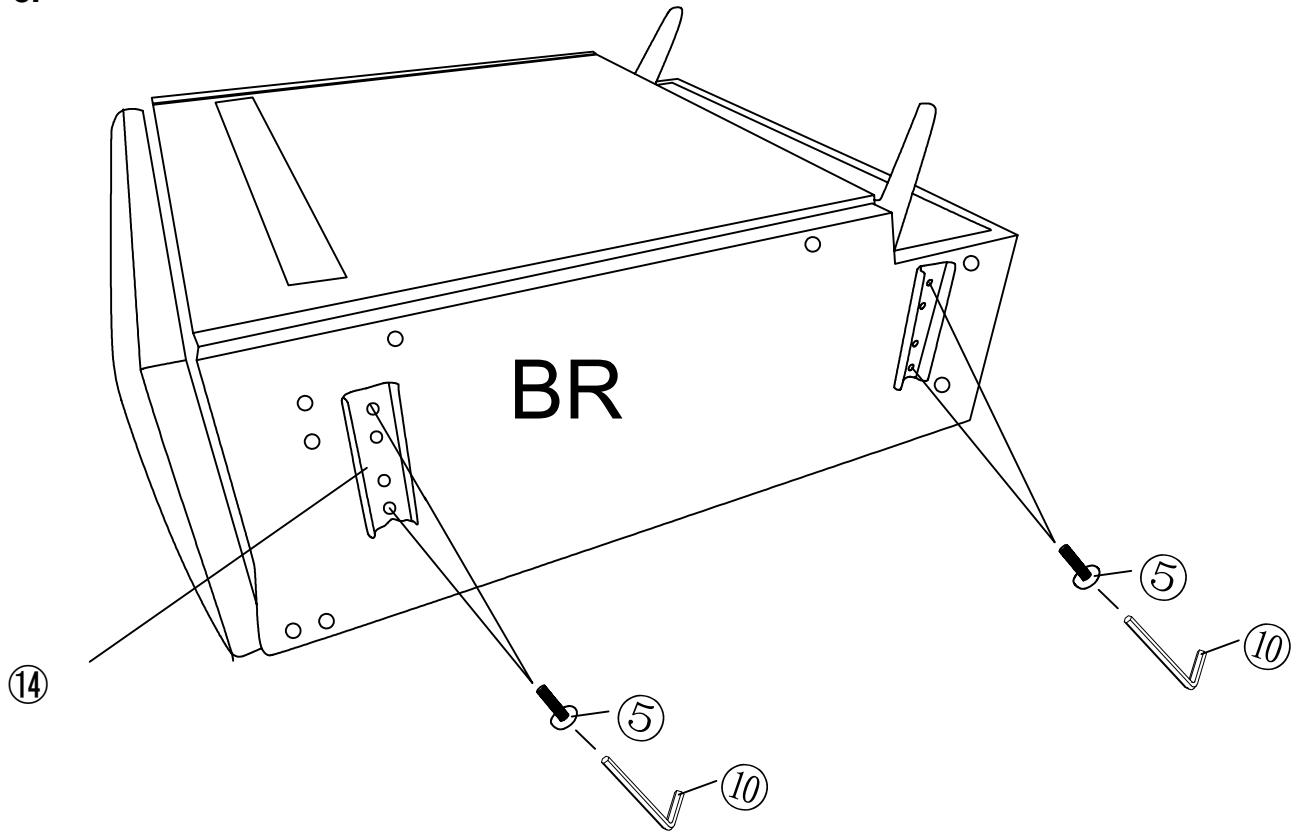

STEP 6:

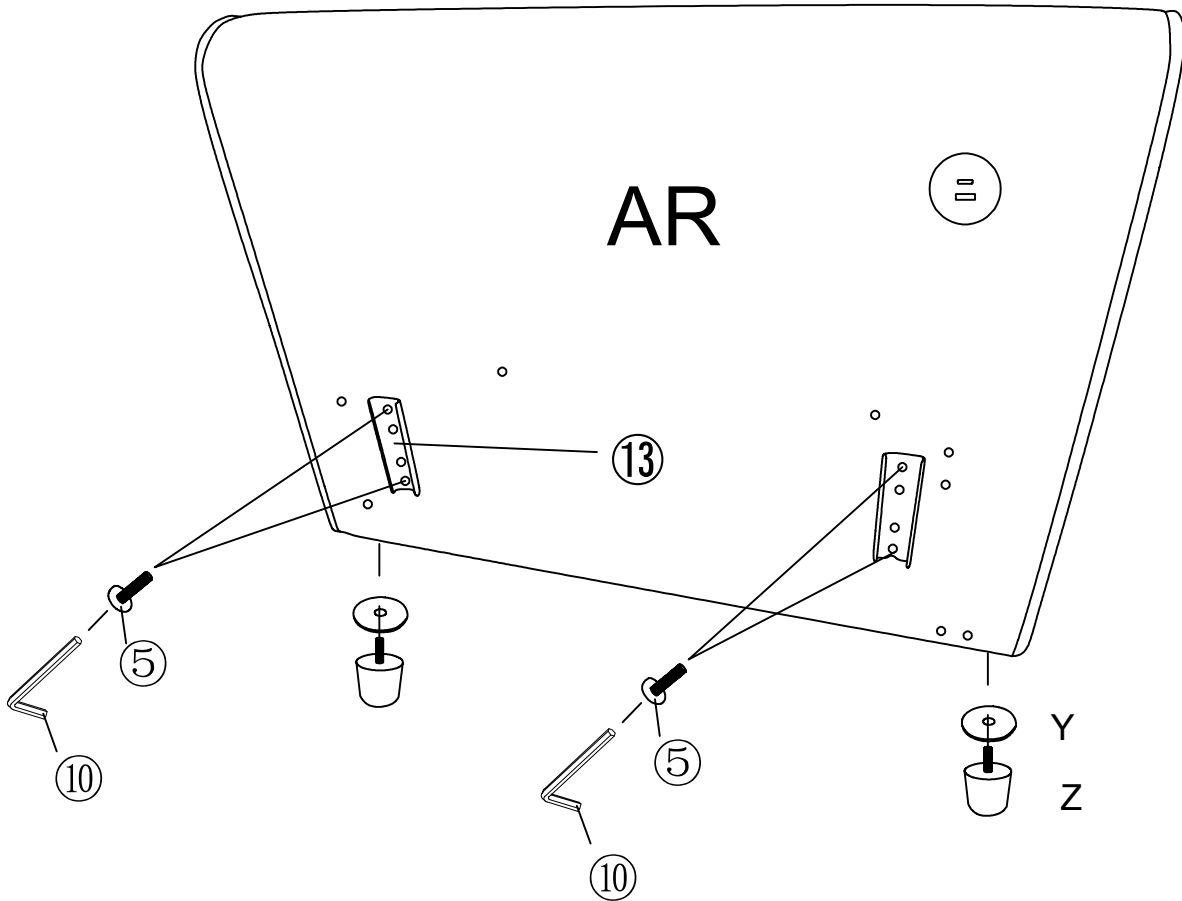

STEP 7:

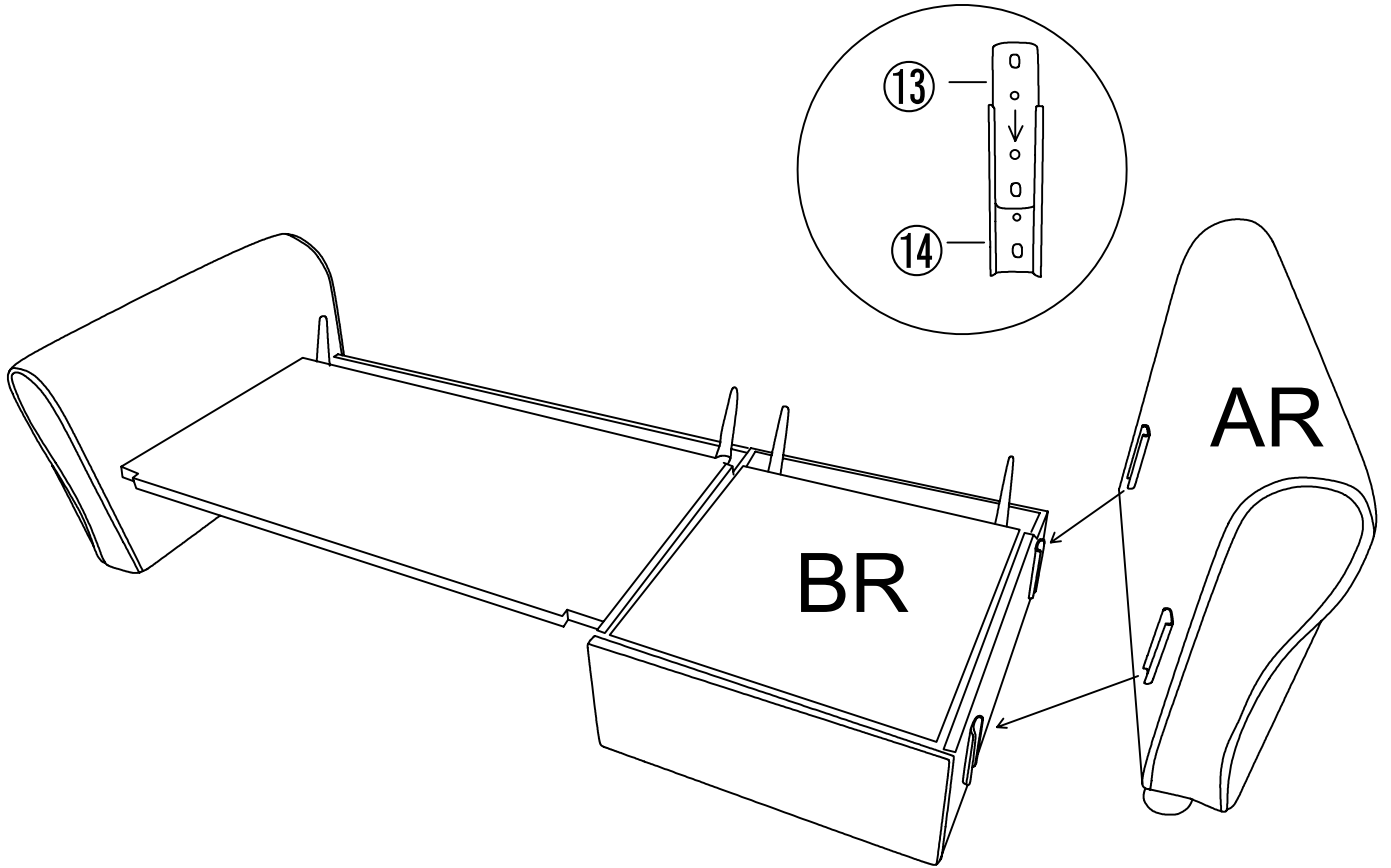

STEP 8:

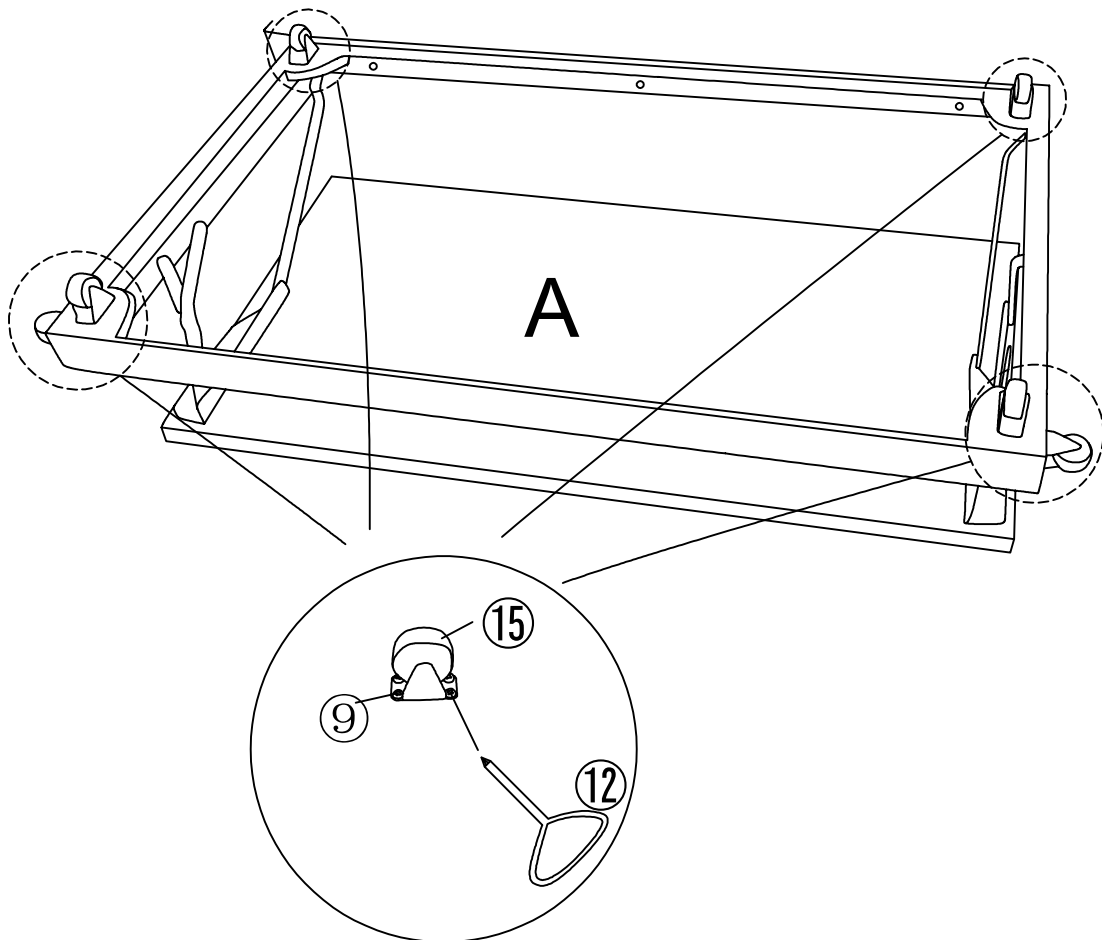

STEP 9:

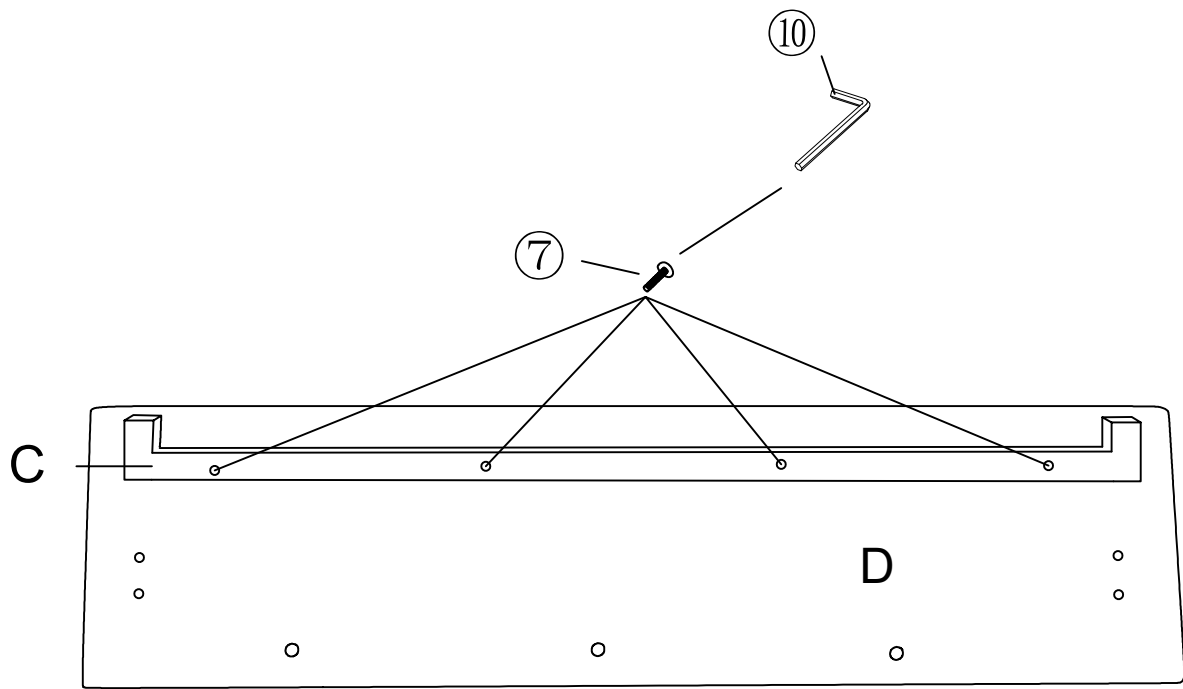

STEP 10:

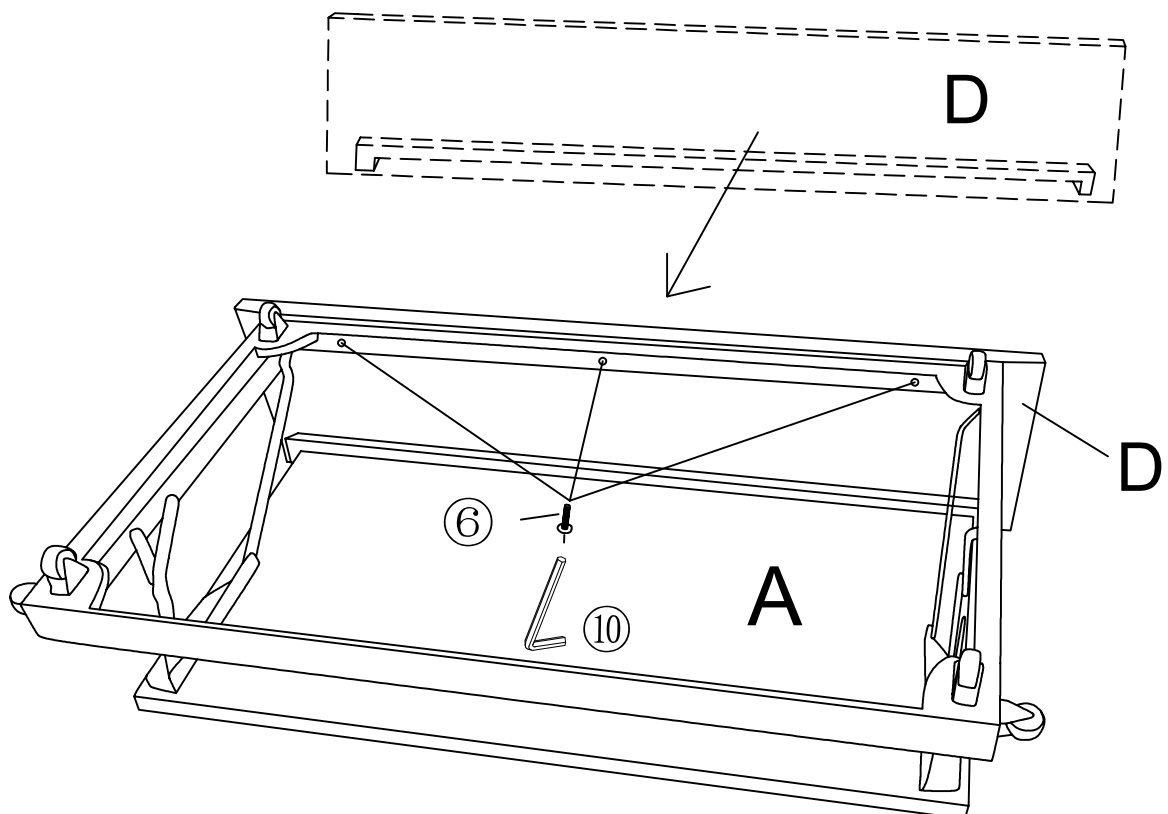

STEP 11 :

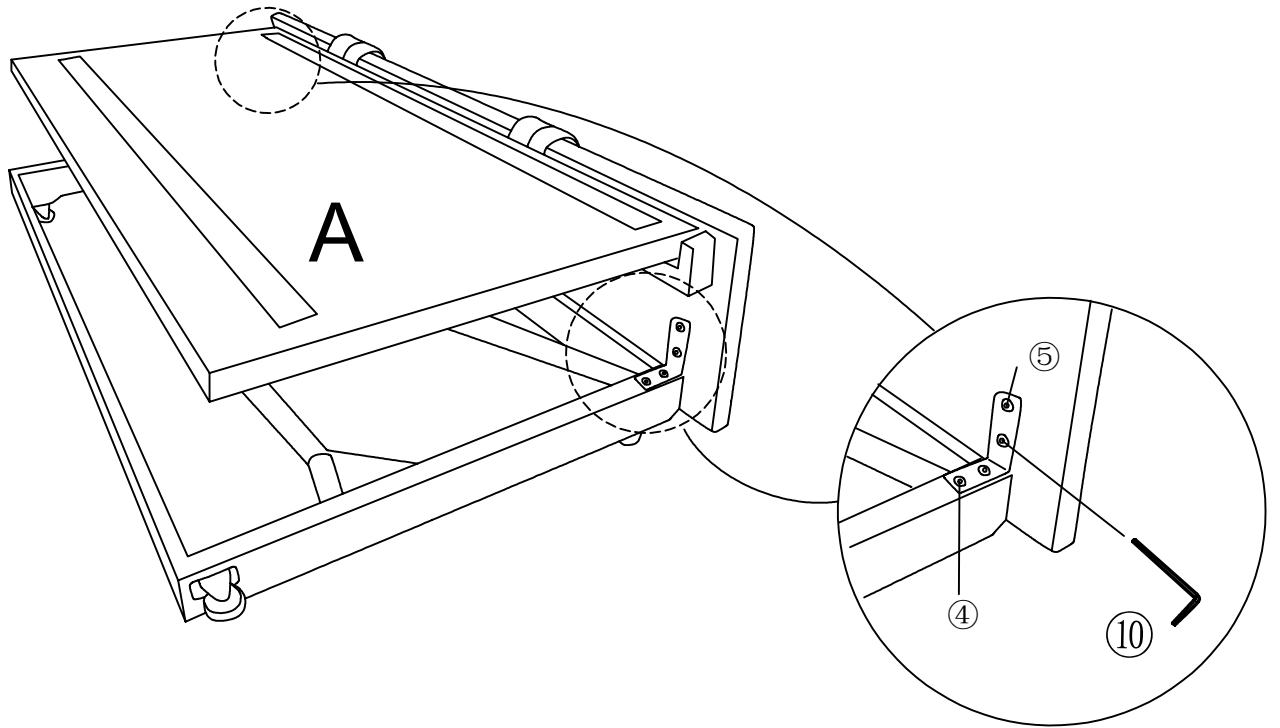

STEP 12:

When adjusting the two-seat backrest CL gear positions, ensure both sides are synchronized. A click sound indicates that the gear has been successfully engaged.

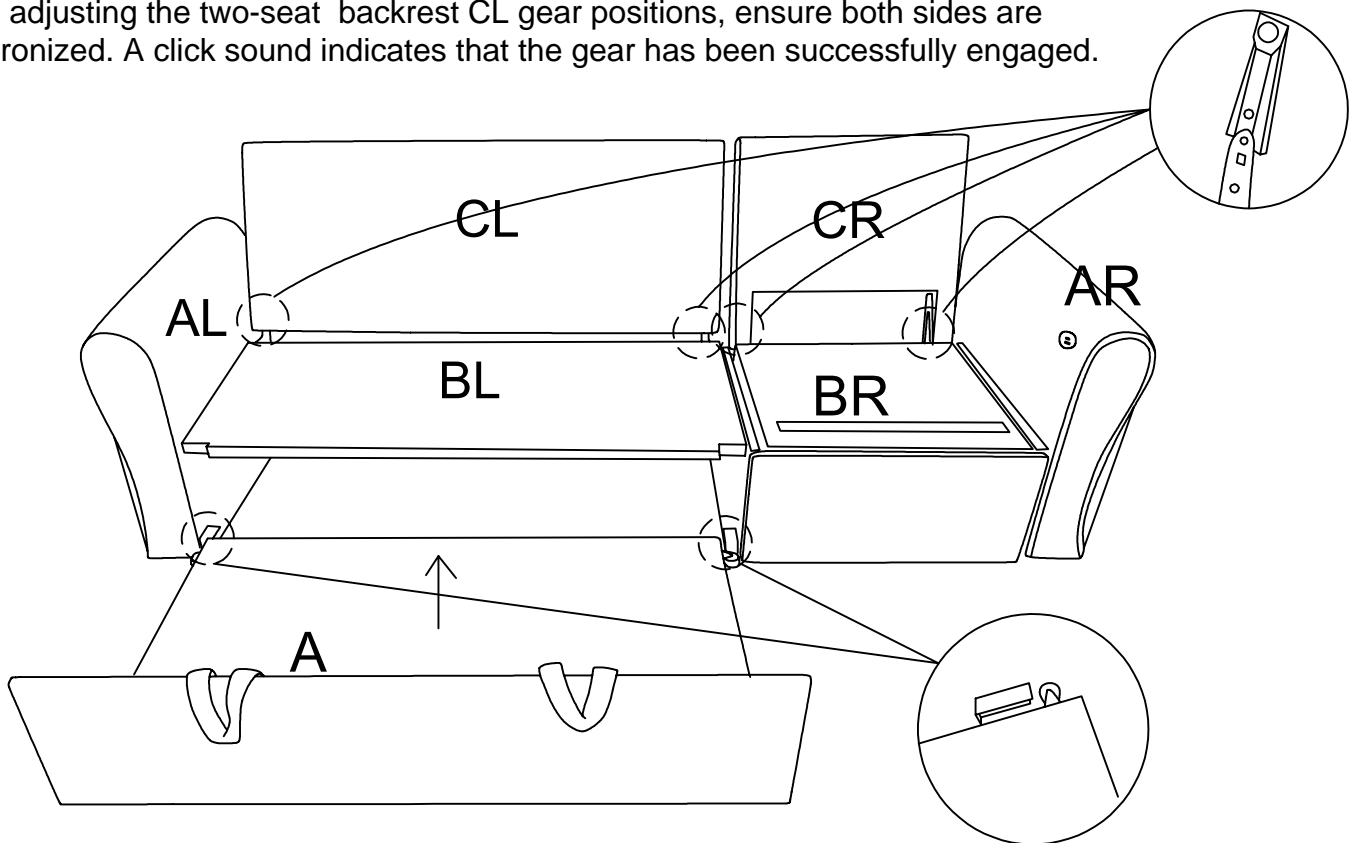

Helpful Hints

- Sofa bed can transform into a sleeper.
- Your furniture can be disassembled and reassembled to move.
- Clean the product with a soft damp cloth. DO NOT use harsh chemicals or abrasive cleaners.

COMPLETED

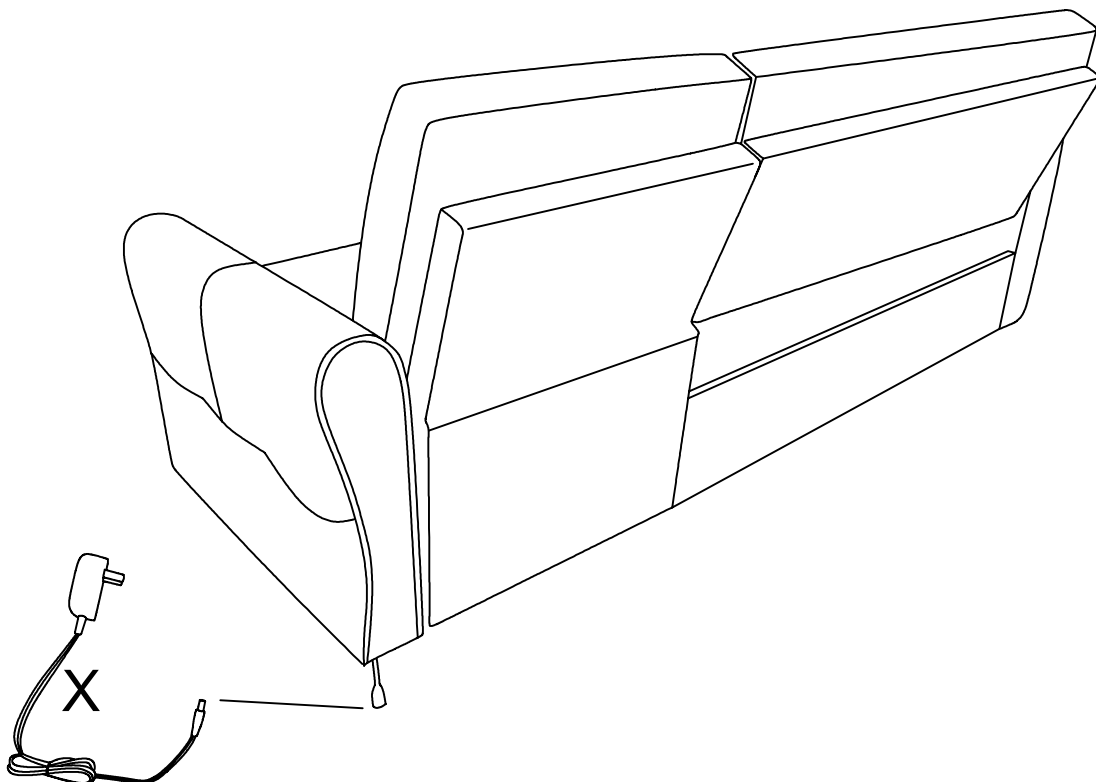
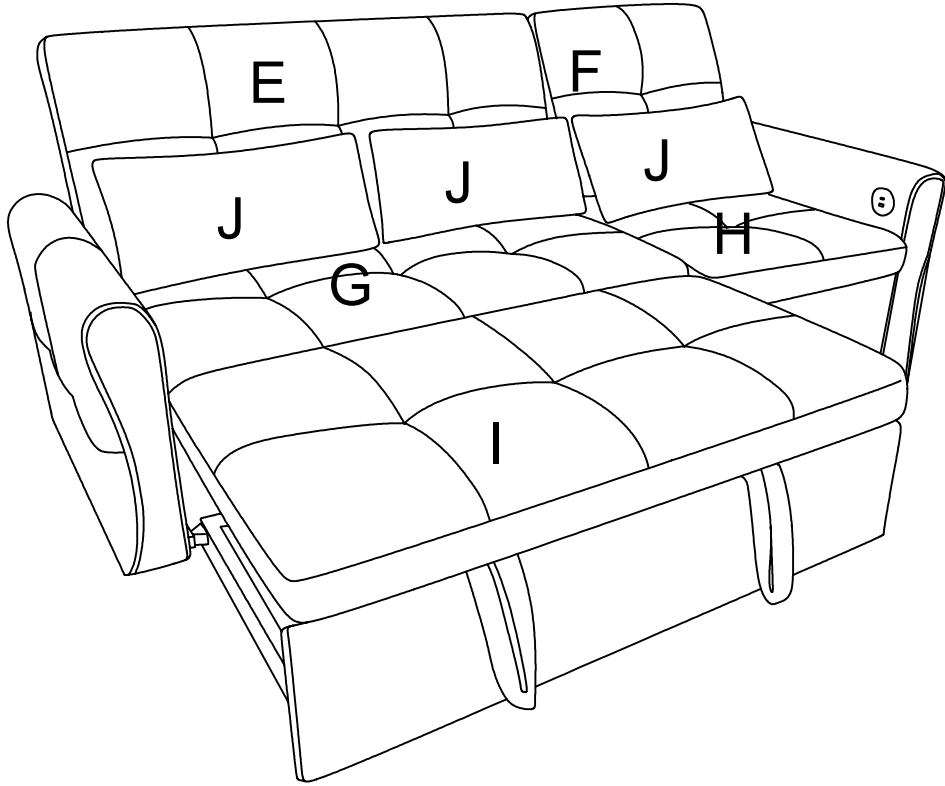

VERSION 1

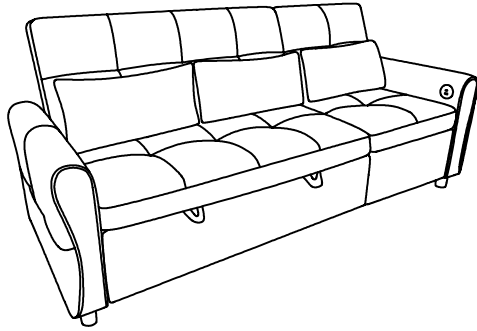

or

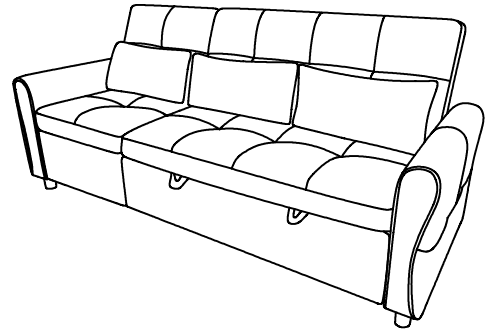

VERSION 2

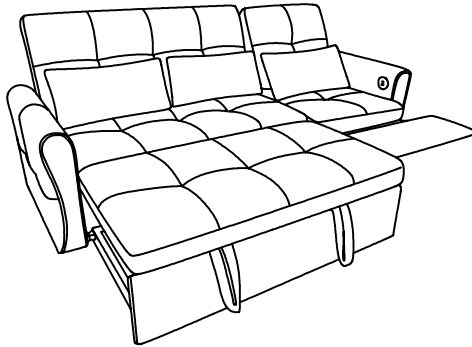

or

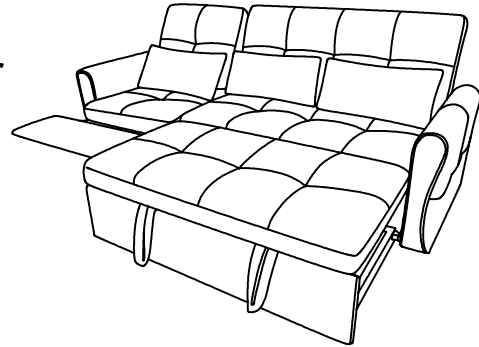

VERSION 3

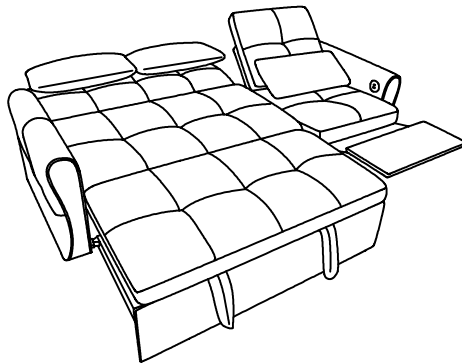

or

