

Installation Manual

TKCD01-B48

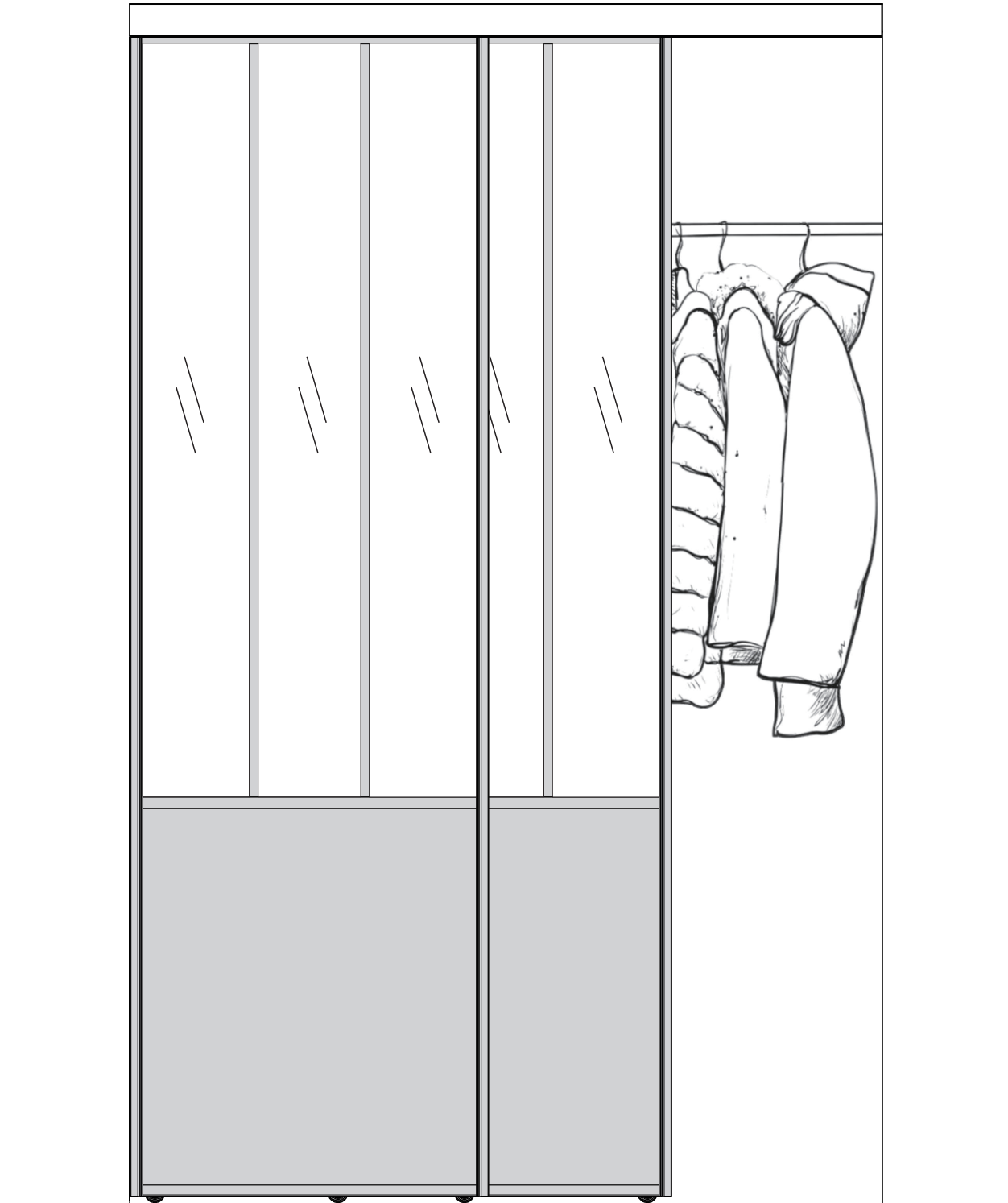

Components list

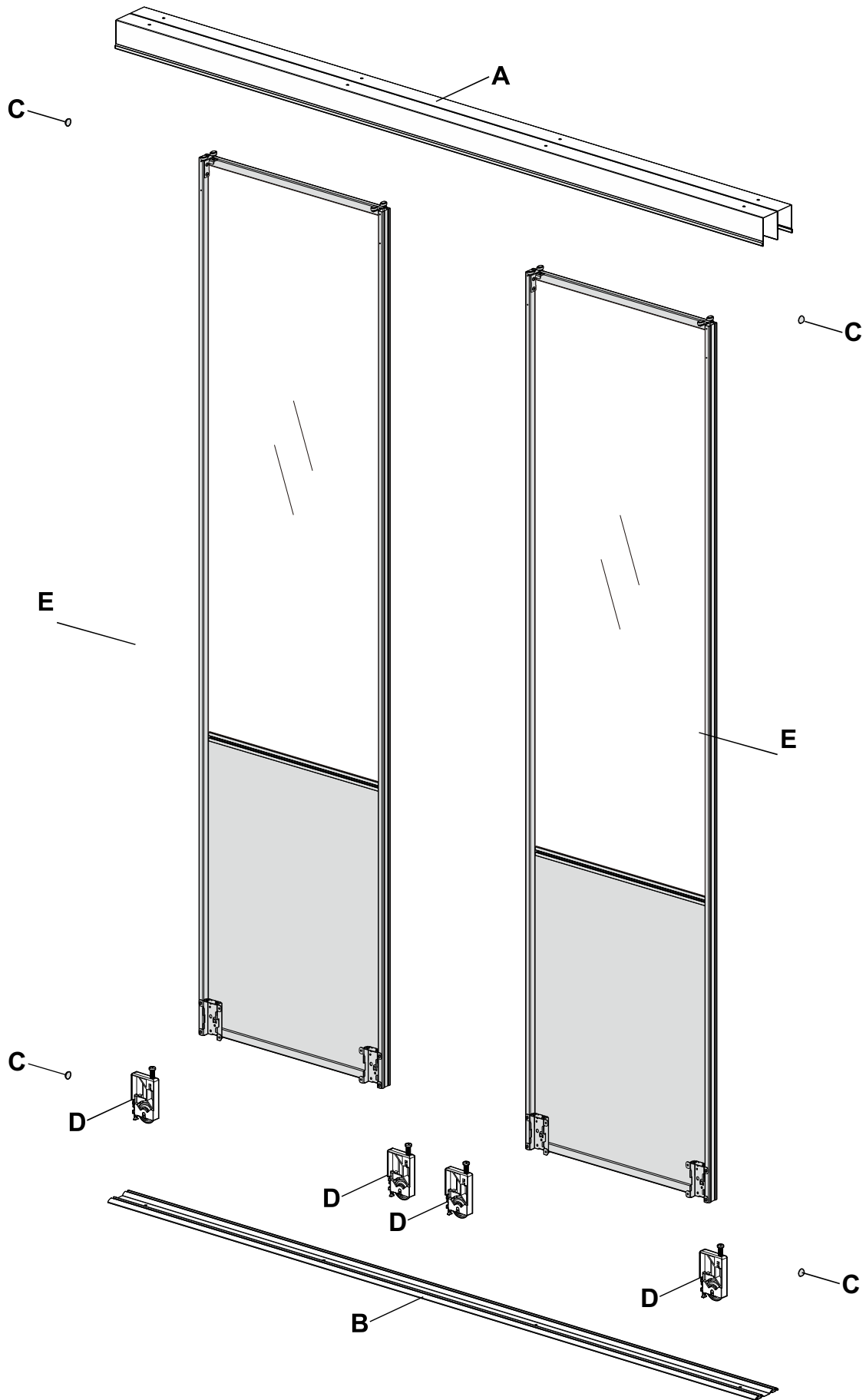



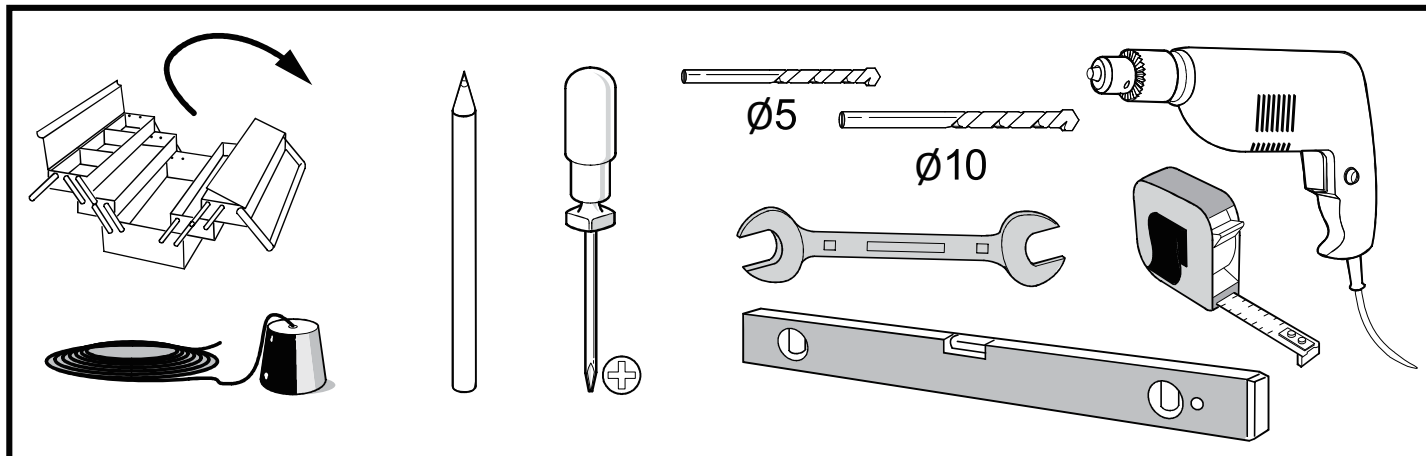

Pre-installation

TOOLS REQUIRED

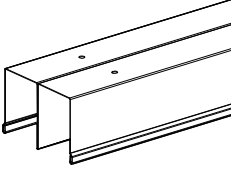

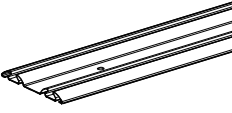
HARDWARE INCLUDED

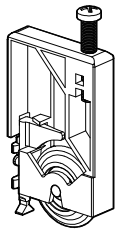
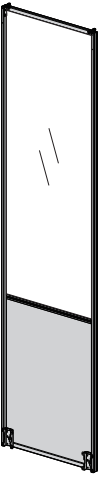
A  ST4.2x16(x8)  (x1)	B  ST4.2x38(x4)  (x1)	C  (x8)
D  (x4)	E  (x2)	

To provide feedback on a particular part, please mark it by circling in the instruction manual and kindly send us a photo.

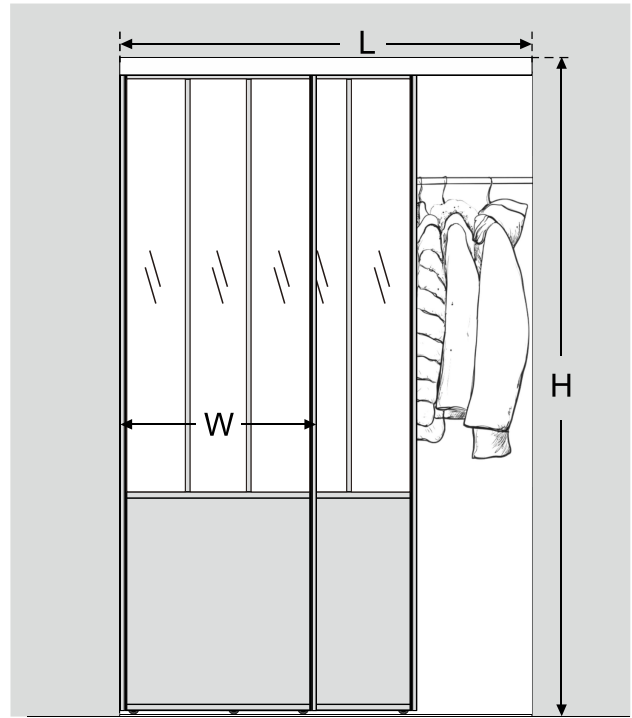
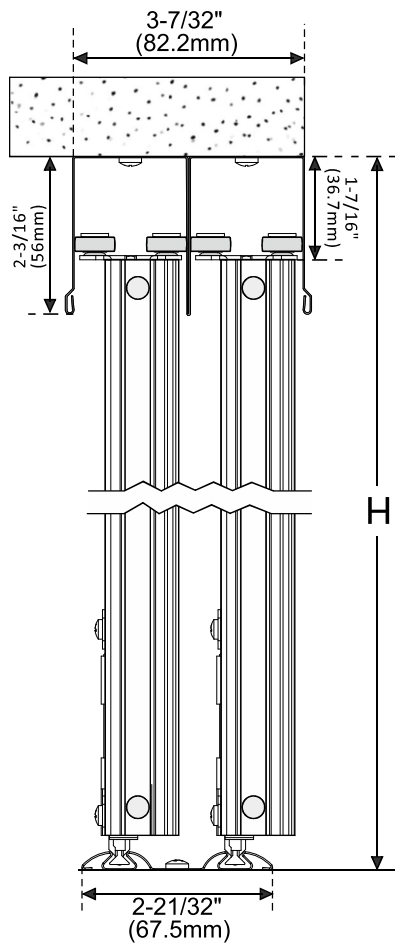

Installation

Step1: Removing the Existing Doors

Remove existing doors, brackets, top channel and bottom track.

Step2: Install Top Channel

- A. Measure the opening at the top of the closet from wall to wall.
- B. Cut the Top Channel to measured dimension. Use a Miter Box and Hacksaw for a straight cut. Cut one end only.

NOT : If your closet has wall jambs you may need to notch your Top Channel on each end.

- C. Locate Top Channel up to the top front of closet opening, making sure that the front of the Top Channel is flush with outside walls. Fasten Top Channel in place using ST4.2 x 16 screws.

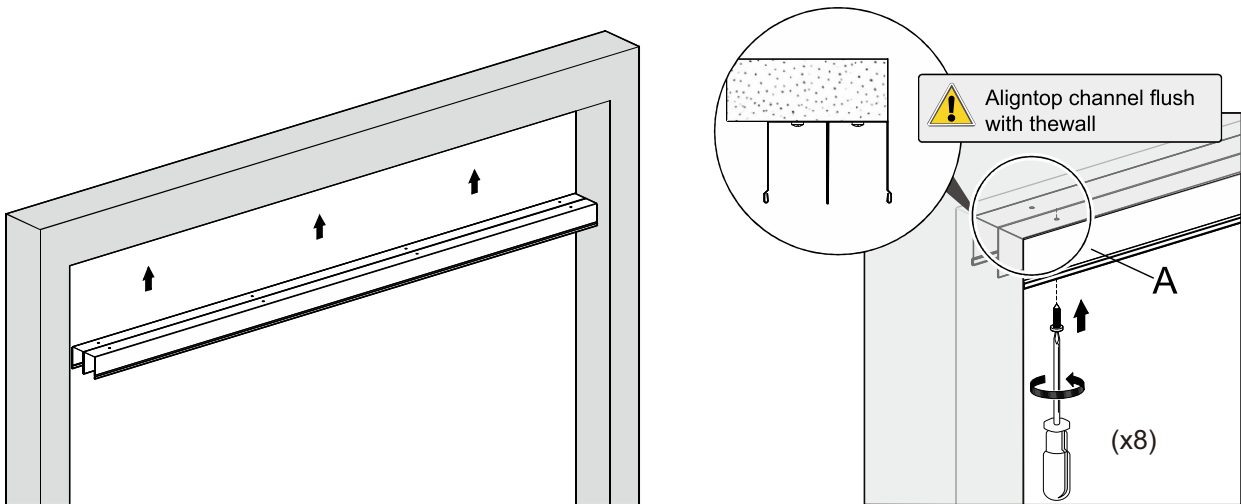

Step3: Install Bottom Track

Measure opening at the bottom of the closet from wall to wall. Cut the Bottom Track to desired dimension. Locate Bottom Track 0.45" (11.35mm) back from the front edge of jamb and attach with ST4.2 x 38 Screws.

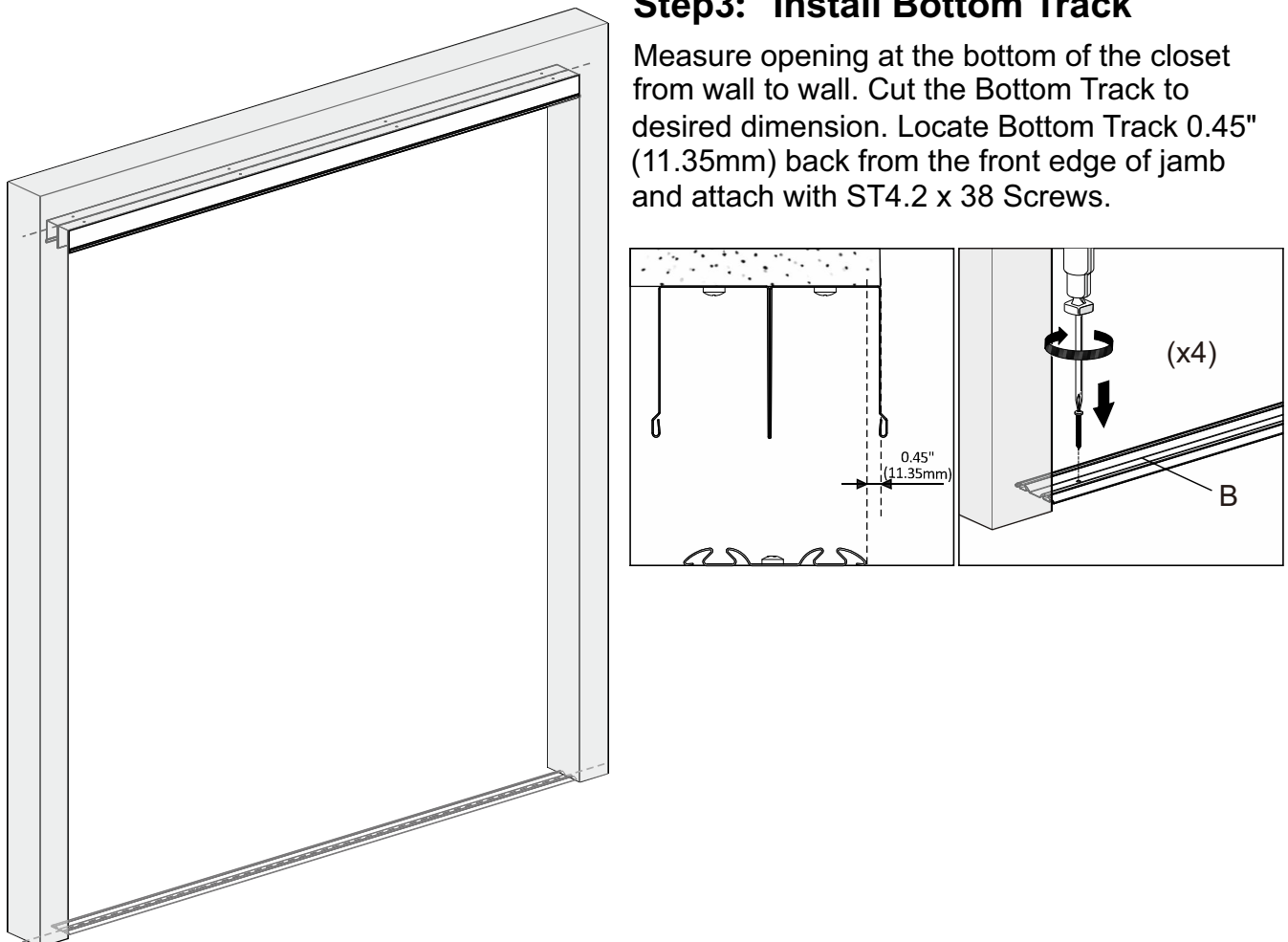

Step4: Install Door Panels

A. Locate the Steel Roller Assemblies on the bottom of Door Panel.

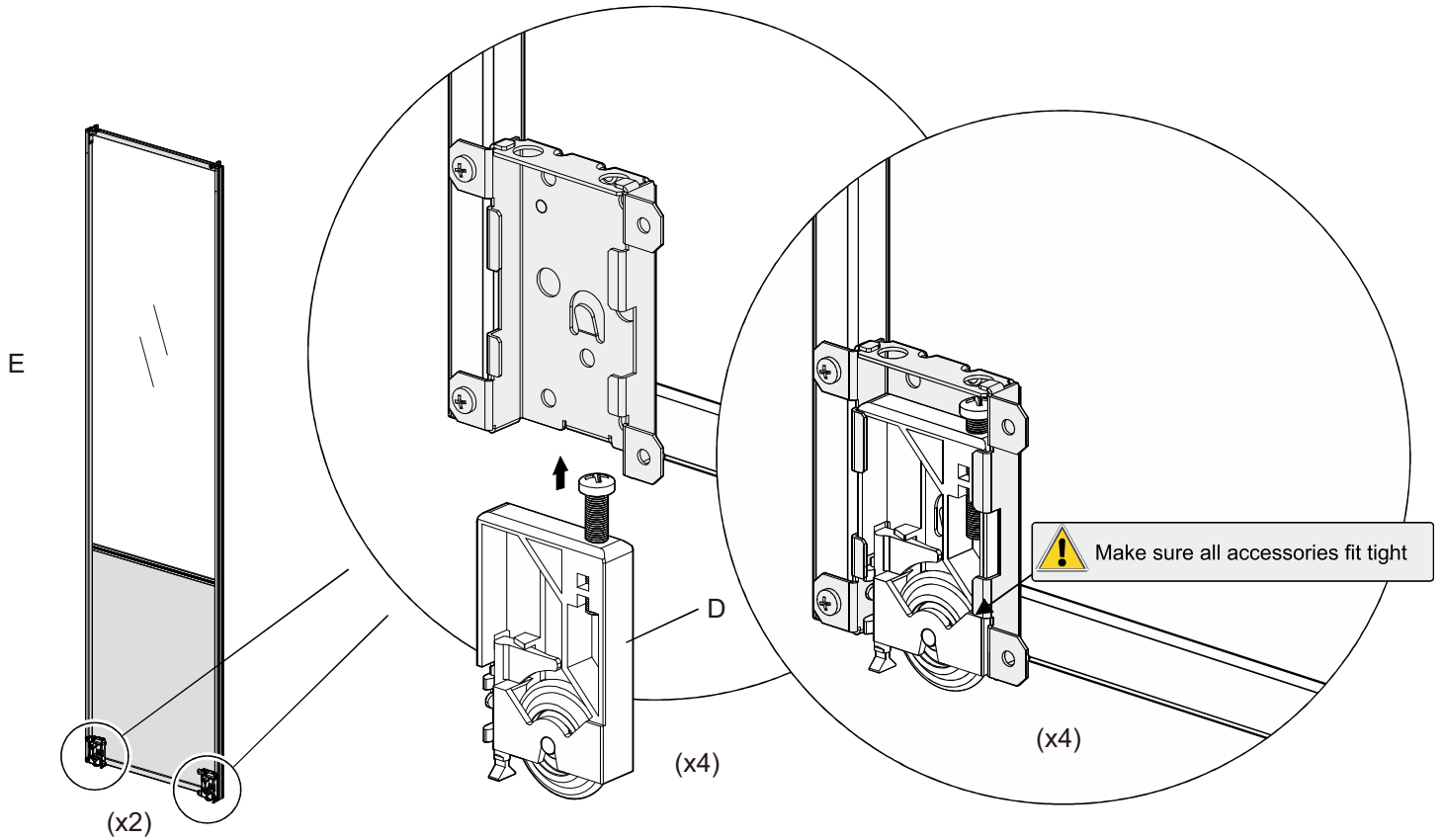

B. Install rear door first

Stand inside closet with the mirrored side facing outward. Tilt the top of the panel back and slip into the back track of the top channel. Swing door towards back of closet, set the bottom of the panel into the rear groove of the Bottom Track.

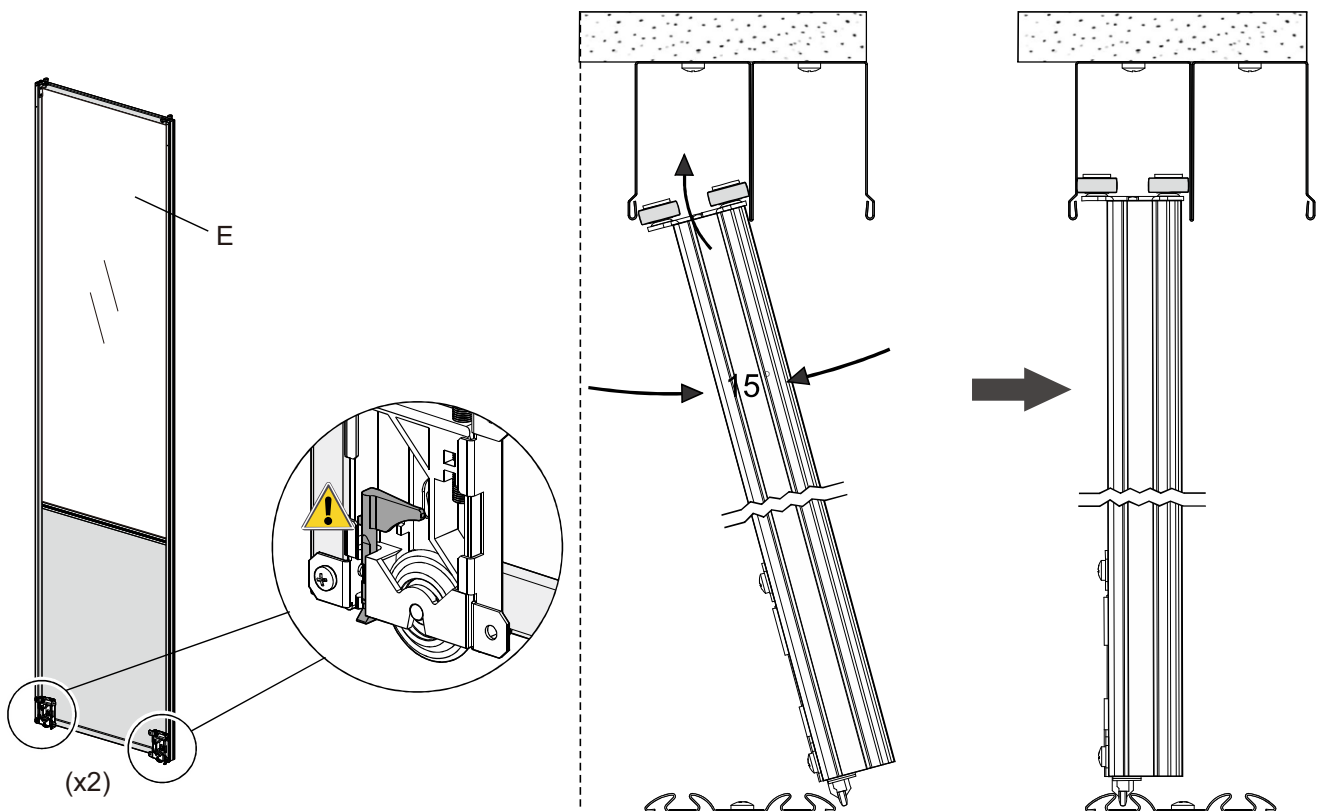

C. Install Front Door Panel

Install front door from outside of closet. For the front panel, repeat Step 4, but place the panel into the front track of the top channel and front groove of the bottom track.

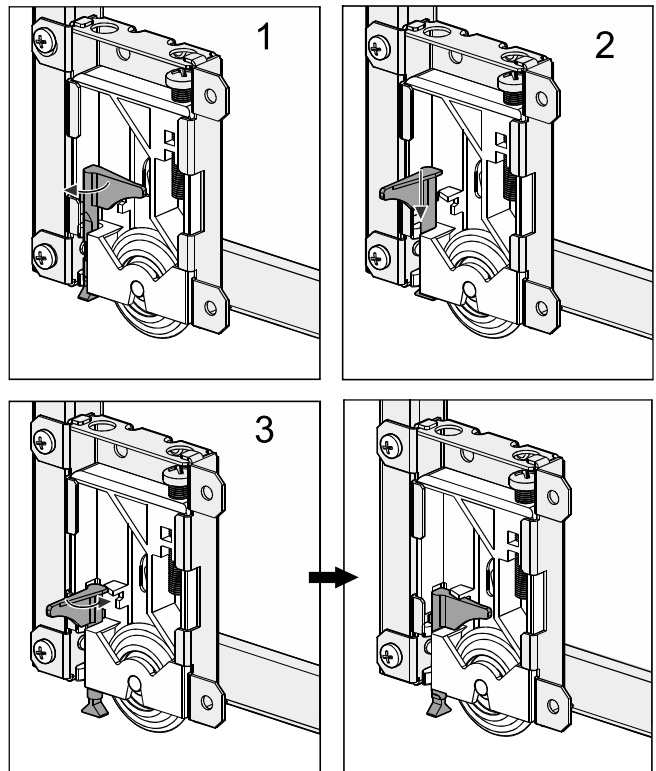
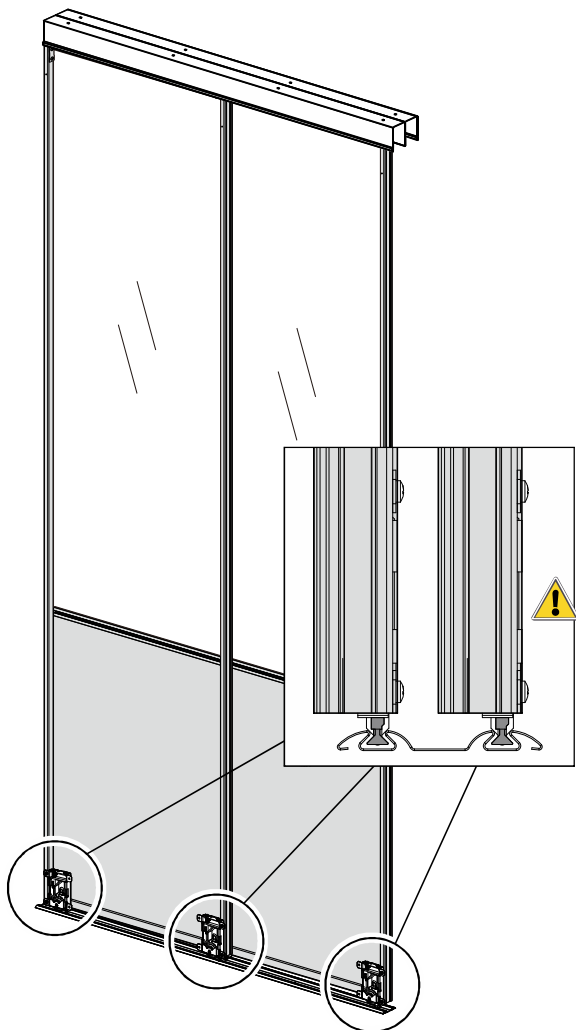
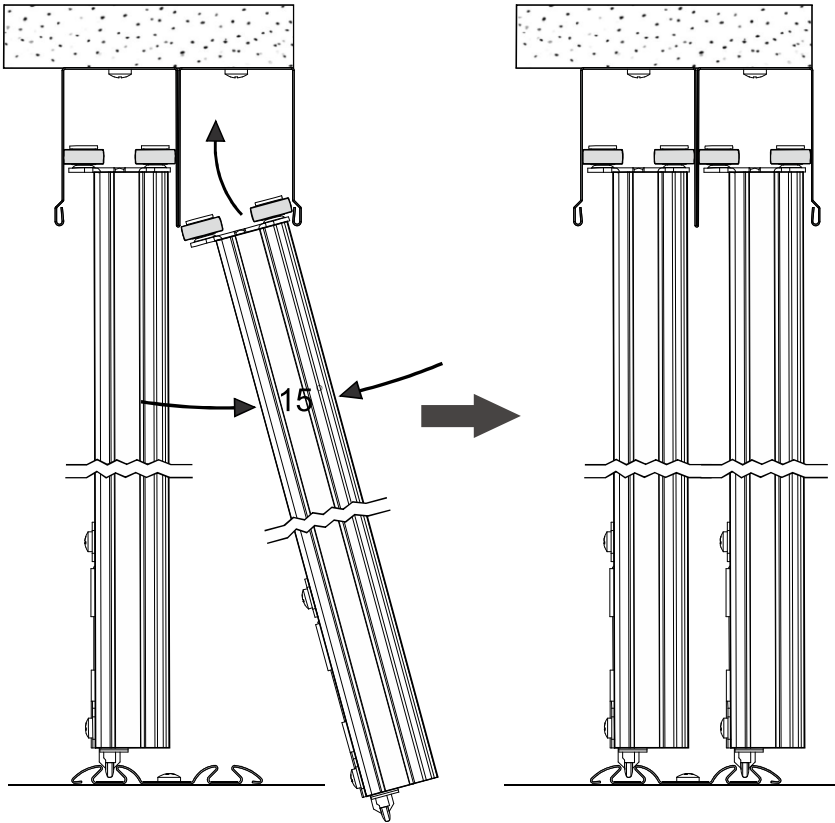

Step5: Install Bumpers

Attach bumpers on the edge of the panel at both top and bottom.

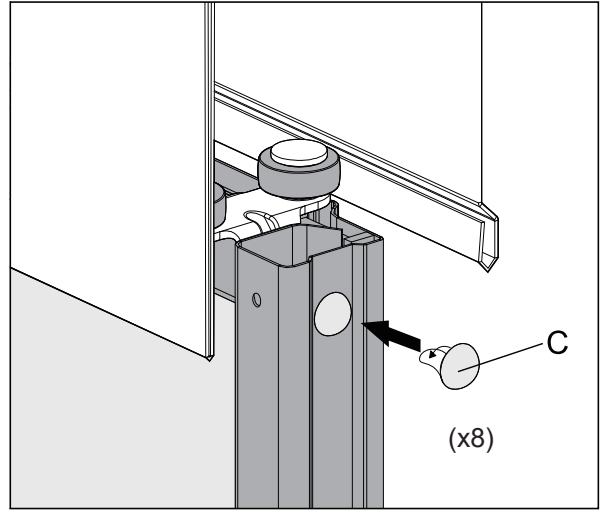
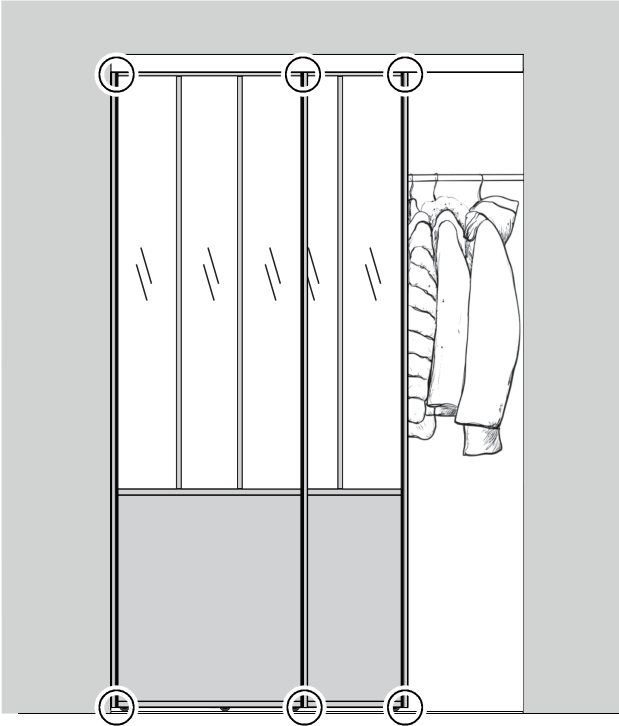

Step6: Adjust Door Panels

Use a phillips screwdriver at bottom roller bolts to adjust height of door. Turn bolt clockwise to raise door and counterclockwise to lower door.

