











# ASSEMBLY INSTRUCTION

ITEM NO.: AC310 / AC311 / AC312

HARDWARE LIST			
Item	Description	Drawing	Pcs
A	Bolt 5/16*45		6
B	Bolt 5/16*100		2
C	Spring washer 5/16"		8
D	Flat washer 5/16"		8
E	Allen key M4		1

PART LIST			
Item	Description	Drawing	Pcs
1	SEAT		1
2	SEAT CUSHION		1
3	BACK		1
4	BACK CUSHION		1
5	RIGHT LEG		1
6	LEFT LEG		1

## STEP : 1

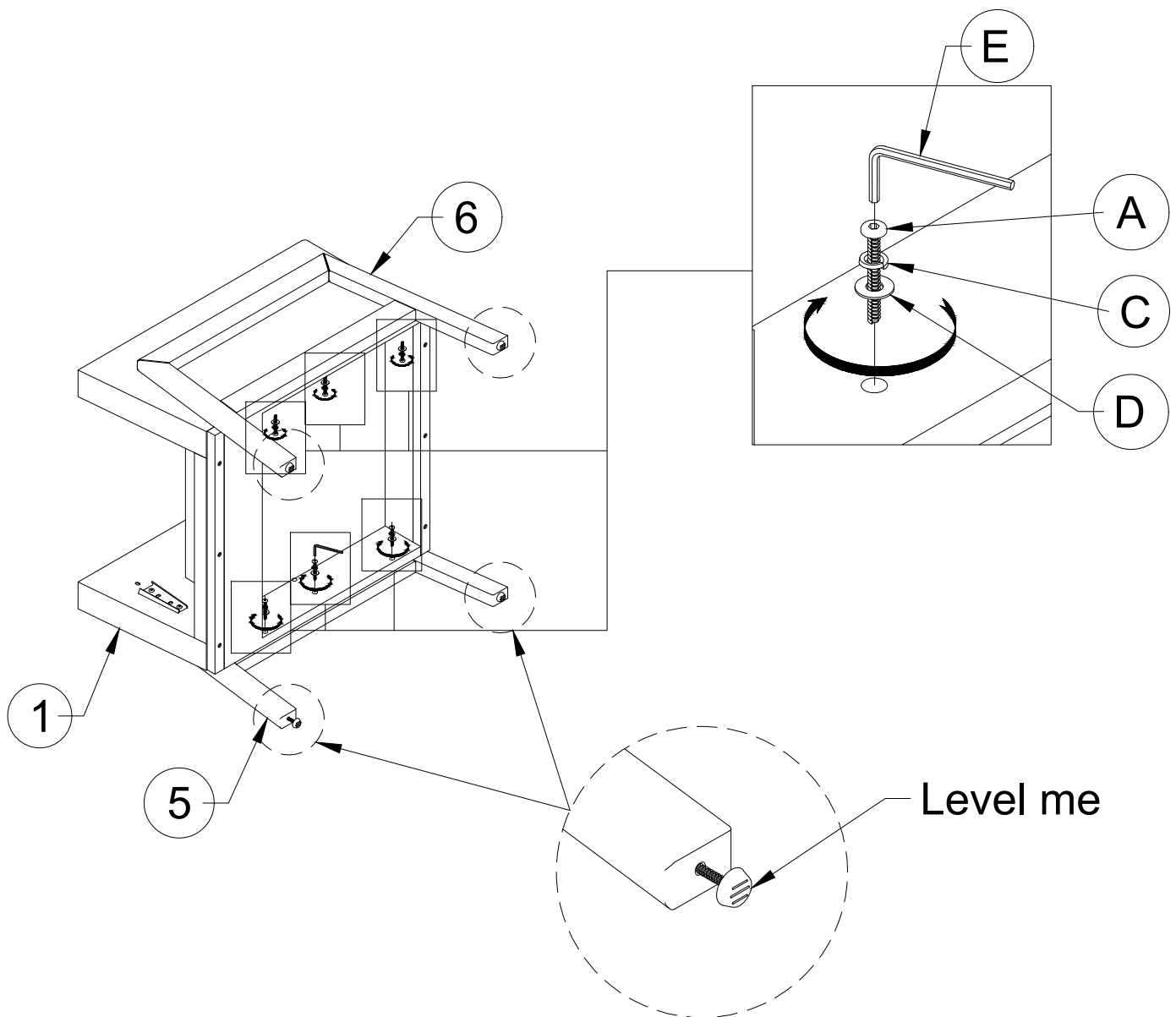

Do not tighten bolt until completely assembled

## STEP : 2

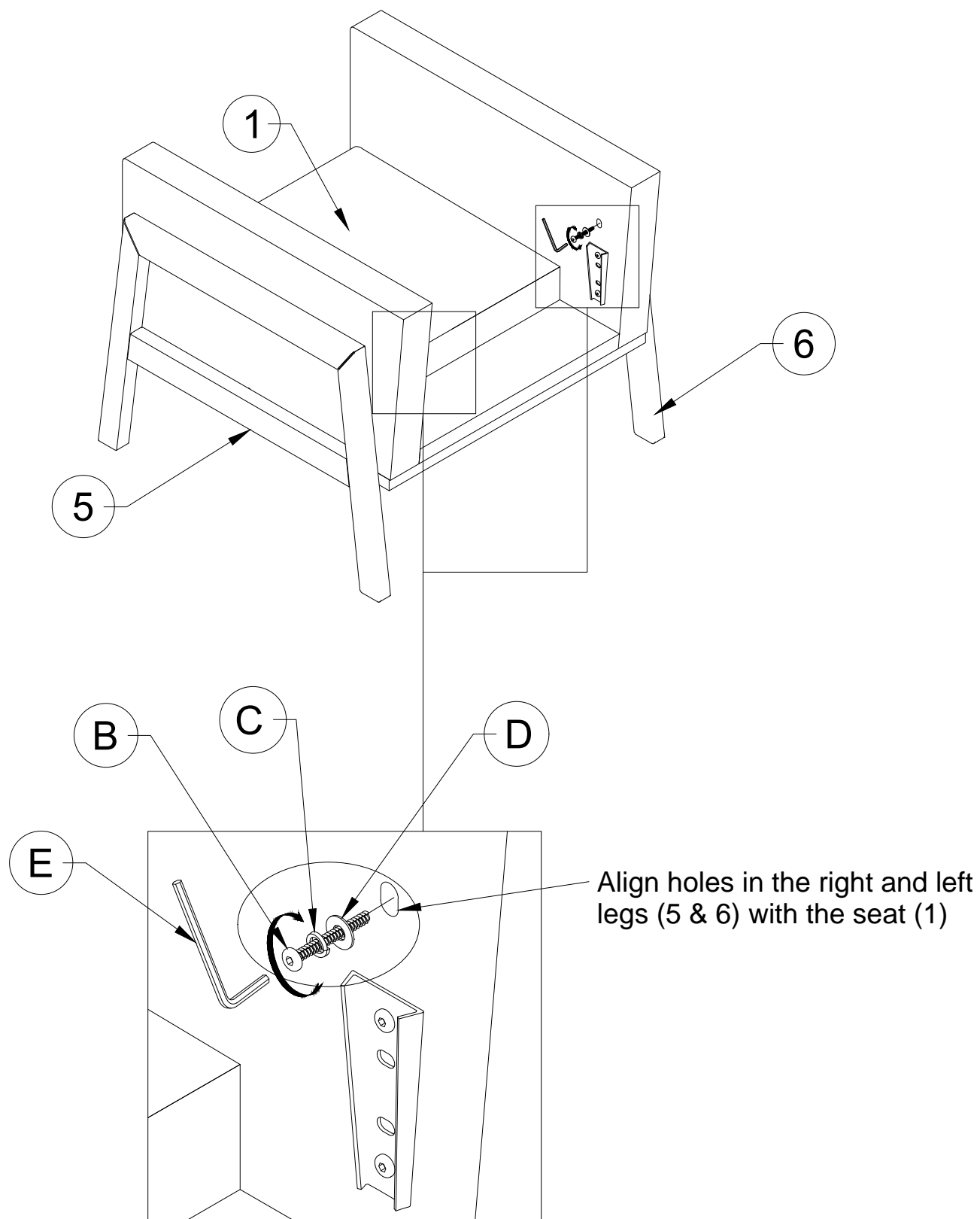

Do not tighten bolt until completely assembled

### STEP : 3

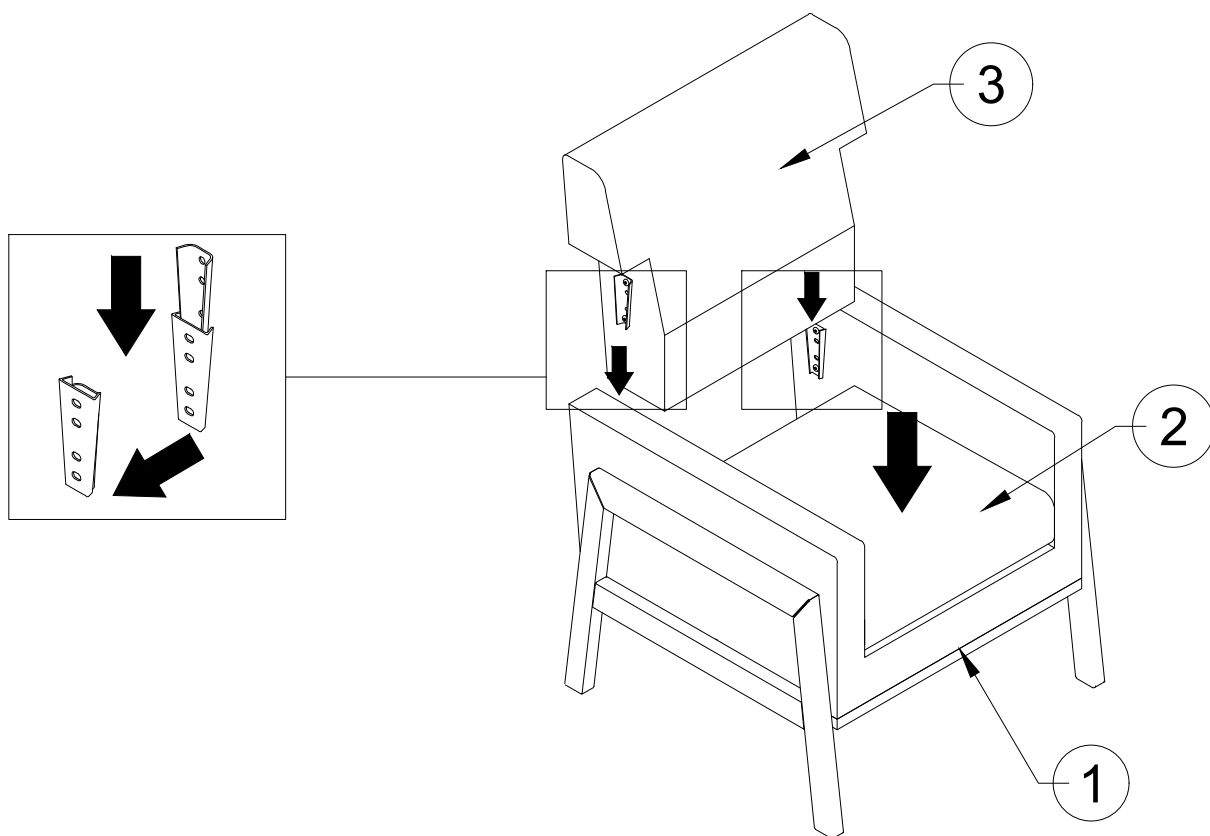

### STEP : 4

**COMPLETE**

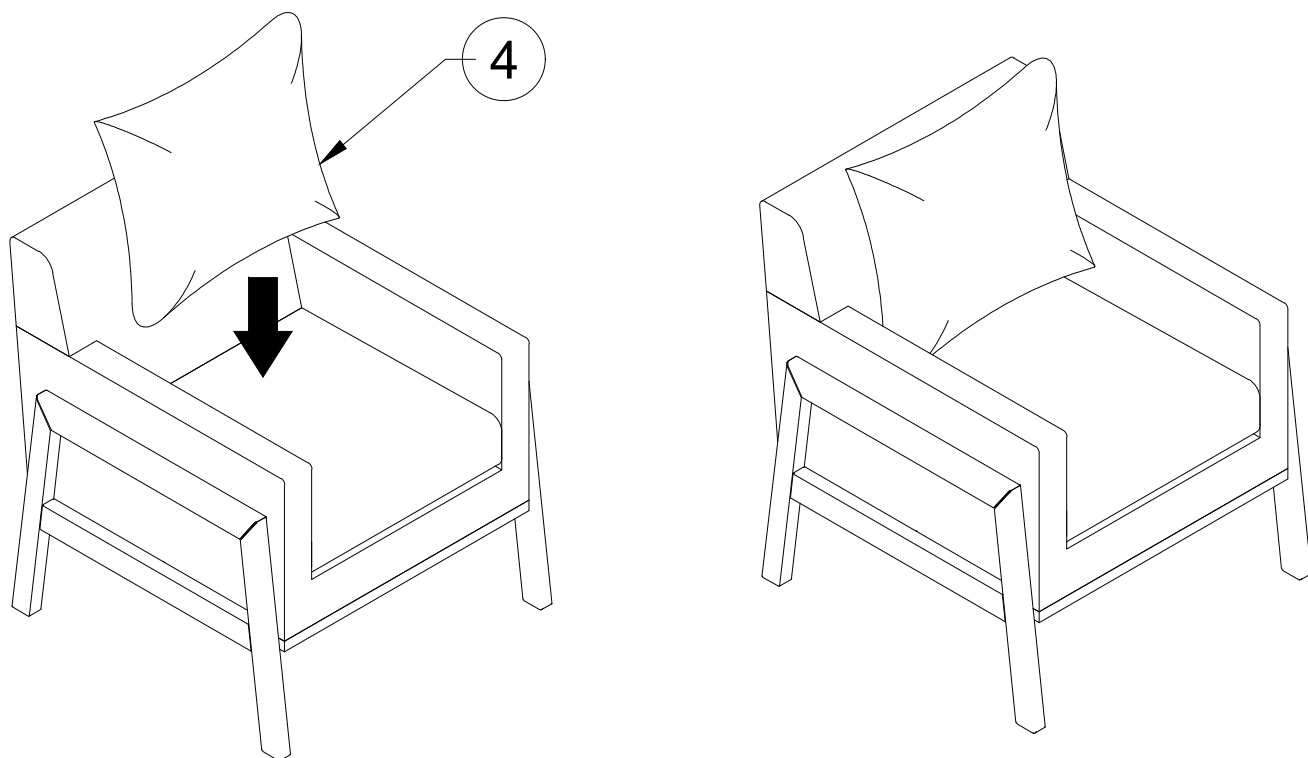

**Do not tighten bolt until completely assembled**