

# STANDARD HEADBOARD ASSEMBLY

## COMPONENTS

---

ITEM	DESCRIPTION	QTY
<b>A</b>	Headboard	1
<b>B</b>	Headboard Leg	2

*Please note: actual headboard may look different than illustration.*

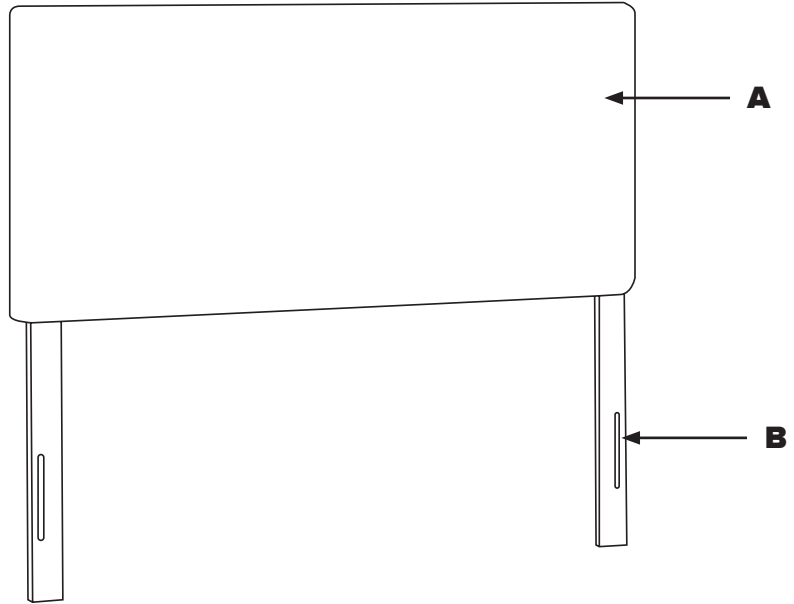

## HARDWARE

---



**(H1)** x 4  
5/8" x 5/16" bolt



**(H2)** x 12  
1 1/4" washer



**(H3)** x 4  
1 x 1/4" bolt



**(H4)** x 4  
1/4" nuts

*Please note: you will need a flat head screwdriver and a wrench to assemble your headboard.*

## LIMITED WARRANTY

---

We guarantee our upholstered furniture against defects in construction for a period of one (1) year. When a structural defect is brought to our attention, we will repair or replace it at our option at no charge to the customer (includes parts and labor, not transportation costs). Fabric wearability for upholstered furniture is not covered by the warranty. Vacuum for regular cleaning.

PLEASE DISPOSE OF PLASTIC BAG(S) AND CARTON(S) RESPONSIBLY.

# STANDARD HEADBOARD ASSEMBLY

## STEP 1 - ATTACHING THE HEADBOARD LEGS

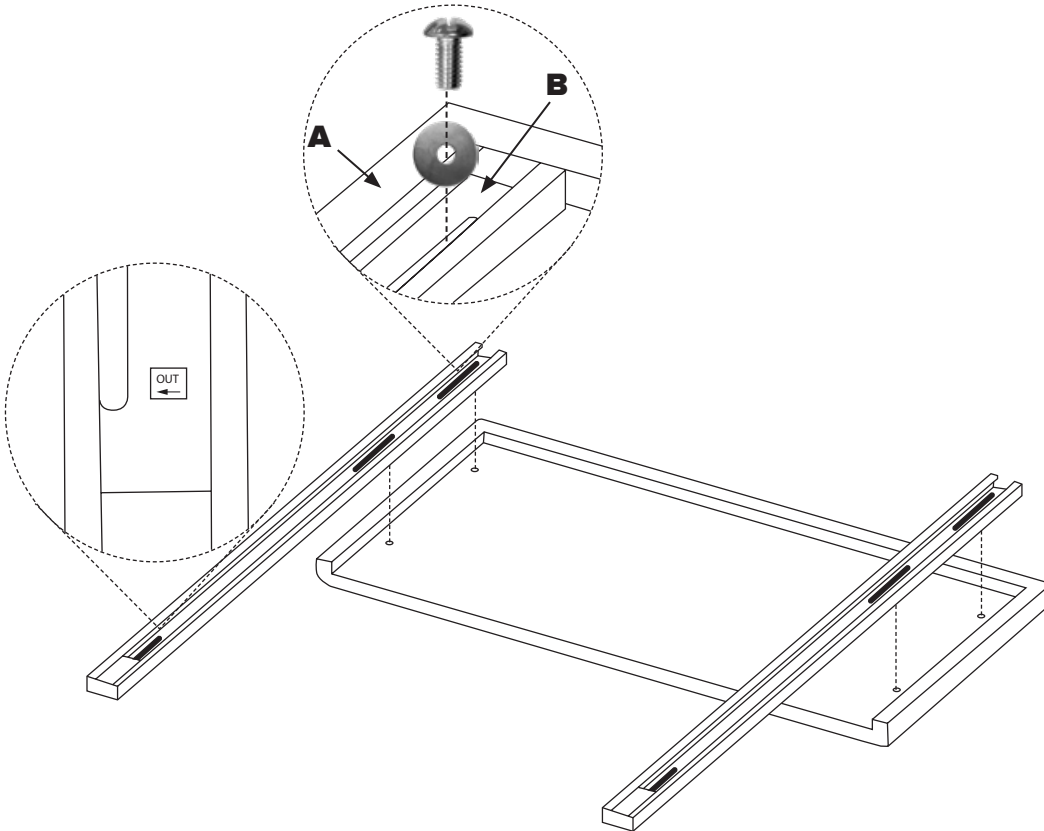

### 1.1

Place (A) headboard face down on a flat surface. Place (B) headboard legs on the back of (A) headboard, aligning the slots of the legs with the holes of the headboard.

*Please note: Make sure the “Out” sticker on each (B) headboard leg is facing the correct way.*

### 1.2

Attach (B) headboard legs to (A) headboard using (H1) bolts and (H2) washers. Tighten with a flat head screwdriver.

## STEP 2 - ATTACHING THE HEADBOARD TO YOUR BED FRAME

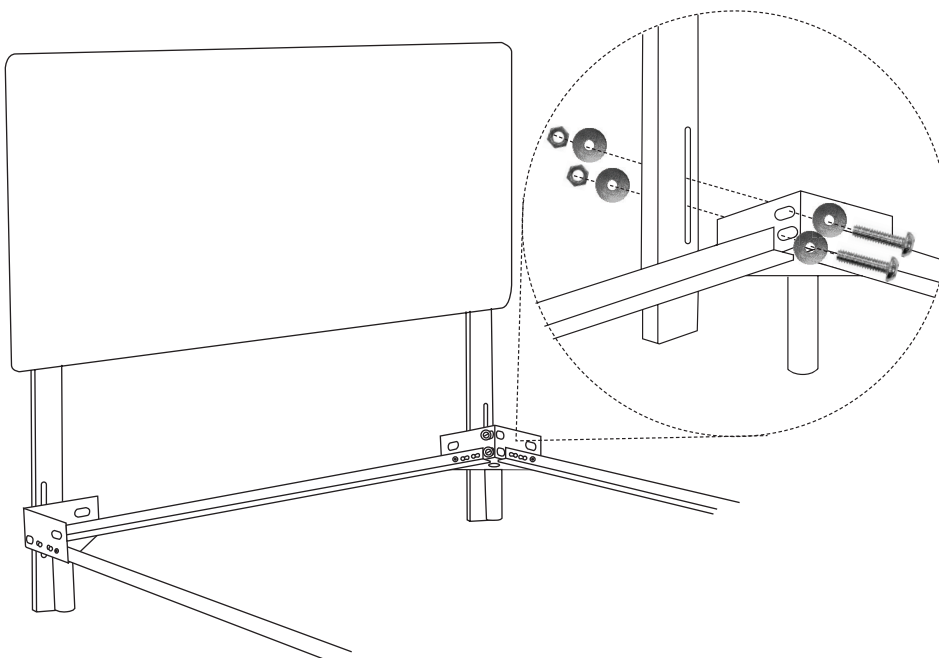

### 2.1

Attach the assembled headboard to your bedframe using (H3) bolts, (H2) washers and (H4) nuts. Tighten with a flat head screwdriver and wrench.

*Please note: The height of your headboard can be adjusted by loosening the (H1) bolts and shifting the (A) headboard up or down.*

