

Product manual  
Gebrauchsanweisung  
Manuel du produit  
Manual del producto  
Manuale del prodotto

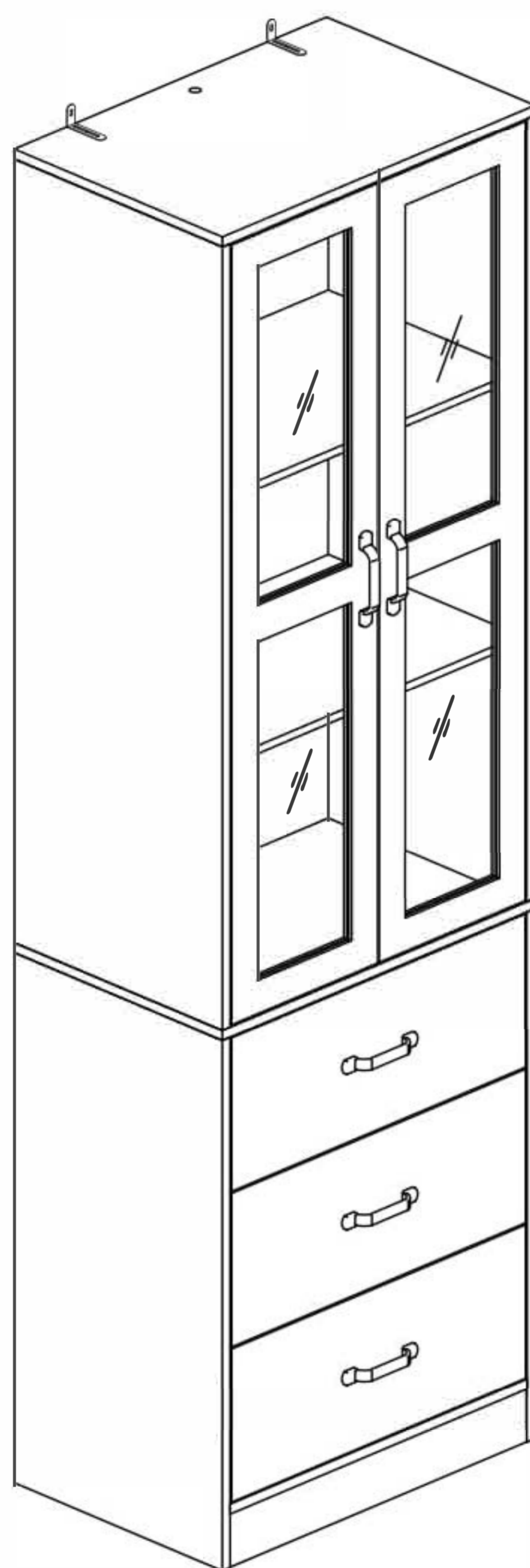

EN:Our product will be delivered to you in 2 packages.  
The delivery times of these 2 packages may differ, please  
be patient and thank you for your understanding

FR:Notre produit vous sera livré en 2 colis.Les délais de  
livraison de ces 2 colis peuvent différer,soyez  
patient et merci de votre compréhension.

DE:Unser Produkt wird Ihnen in 2 Paketen geliefert.Die  
Lieferzeiten dieser 2 Paket können abweichen,bitte haben Sie  
etwas Geduld und vielen Dank für Ihr Verständnis .

IT:I nostri prodotti vengono trasportati in due pacchetti. I tempi  
di consegna dei due pacchetti sono diversi: abbiate pazienza e  
vi ringrazio per la vostra comprensione.

ES:Nuestro producto se entrega en dos paquetes. El tiempo de  
entrega de estos dos paquetes es diferente. Por favor, sea  
paciente. Gracias por su comprensión.

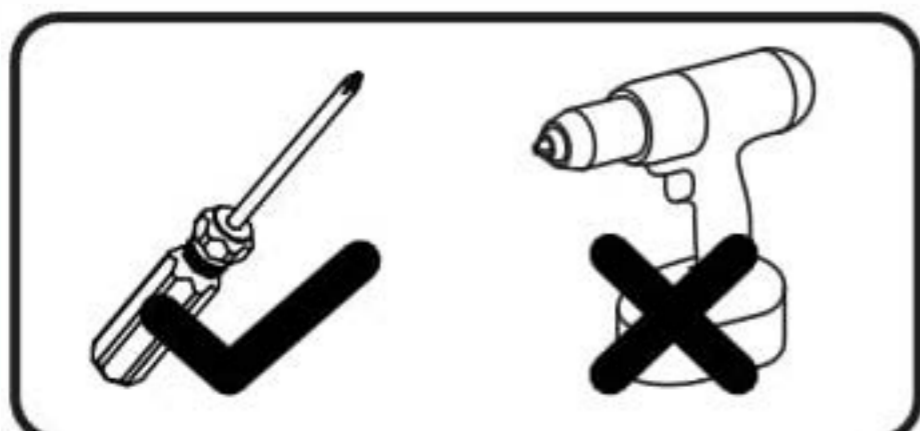
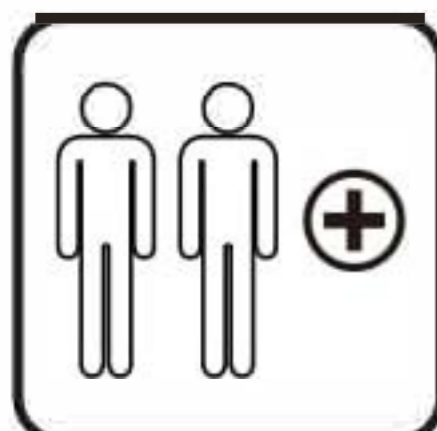



[DE]

**Warnung:** Lesen Sie diese Anleitung vor dem Zusammenbau bitte vollständig durch. Überprüfen Sie, ob Sie alle auf den Seiten aufgeführten Komponenten und Werkzeuge haben. Bewahren Sie die Anleitung zum späteren Nachschlagen auf. Teile des Zusammenbaus lassen sich mit 2 Personen leichter durchführen. Suchen Sie bei Bedarf professionelle Hilfe.

**Warnung:** Legen Sie alle Teile auf eine ebene Fläche. Legen Sie eine weiche Decke oder Ähnliches darunter, um sie vor Kratzern oder Flecken zu schützen. Vermeiden Sie es, Komponenten über den Boden zu ziehen oder zu schieben.

**Warnung:** Überprüfen Sie regelmäßig alle Beschläge und Befestigungen, um sicherzustellen, dass sie sicher sind und um Unfälle zu vermeiden. Wenn Teile fehlen, kaputt, beschädigt oder abgenutzt sind, verwenden Sie das Produkt nicht weiter, bis es mit vom Hersteller autorisierten Teilen repariert wurde.

**Warnung:** Lassen Sie Kinder nicht auf die Möbel klettern, da dies zum Umkippen und zu schweren Verletzungen führen kann. Bauen Sie die Möbel außerhalb der Reichweite von Kindern zusammen.

**Warnung:** Stellen Sie die Möbel nicht in die Nähe von Feuerquellen oder heißen Gegenständen, um Brandgefahr zu vermeiden.

**Warnung:** Reinigen Sie die Möbel mit einem feuchten Tuch oder Alkohol. Verwenden Sie keine Reinigungsmittel mit ätzenden Chemikalien.

**Warnung:** Dieses Produkt ist mit einer Kippschutzvorrichtung ausgestattet. Bitte installieren Sie diese Vorrichtung unbedingt, um unnötige Verletzungen durch Umkippen zu vermeiden.

[EN]

**Warning:** Please read these instructions fully before starting assembly. Check you have all the components and tools listed on pages. Keep the instructions for later reference. Parts of the assembly will be easier with 2 people. Seek professional assistance if necessary.

**Warning:** Please place all parts on a flat surface. Place a soft blanket or similar underneath to protect against scratches or stains. Avoid dragging or sliding components across the floor.

**Warning:** Regularly check all fittings and fastenings to ensure they are secure and to prevent accidents. If any parts are missing, broken, damaged, or worn, discontinue use of the product until repairs have been made using factory authorized parts.

**Warning:** Do not allow children to climb on the furniture as this may result in tipping and serious personal injury. Assemble the furniture away from the reach of children.

**Warning:** Do not place furniture close to fire sources or high-temperature objects to avoid the risk of fire. Do not place furniture in damp environments to prevent material damage.

**Warning:** Clean furniture with a damp cloth or alcohol, avoid using cleaning agents containing corrosive chemicals.

**Warning:** This product is equipped with an anti-tilt device. Please be sure to install this device to prevent unnecessary injuries caused by tipping.

[FR]

**Avertissement :** Veuillez lire attentivement ces instructions avant de commencer l'assemblage. Vérifiez que vous disposez de tous les composants et outils répertoriés sur les pages. Conservez les instructions pour référence ultérieure. Certaines parties de l'assemblage seront plus faciles à 2 personnes. Demandez l'aide d'un professionnel si nécessaire.

**Avertissement :** Veuillez placer toutes les pièces sur une surface plane. Placez une couverture douce ou similaire en dessous pour les protéger des rayures ou des taches. Évitez de faire glisser les composants sur le sol.

**Avertissement :** Vérifiez régulièrement tous les raccords et fixations pour vous assurer qu'ils sont bien fixés et pour éviter les accidents. Si des pièces manquent, sont cassées, endommagées ou usées, cessez d'utiliser le

produit jusqu'à ce que des réparations aient été effectuées à l'aide de pièces autorisées par l'usine.

**Avertissement** : Ne laissez pas les enfants grimper sur les meubles car cela pourrait entraîner un basculement et des blessures graves. Assemblez les meubles hors de portée des enfants.

**Avertissement** : Ne placez pas les meubles à proximité de sources de feu ou d'objets à haute température pour éviter tout risque d'incendie.

**Avertissement** : Nettoyez les meubles avec un chiffon humide ou de l'alcool, évitez d'utiliser des produits de nettoyage contenant des produits chimiques corrosifs.

**Avertissement** : Ce produit est équipé d'un dispositif anti-basculement. Assurez-vous d'installer ce dispositif pour éviter les blessures inutiles causées par un basculement.

[IT]

**Attenzione**: leggere attentamente queste istruzioni prima di iniziare il montaggio. Verificare di avere tutti i componenti e gli strumenti elencati nelle pagine. Conservare le istruzioni per riferimento futuro. Alcune parti del montaggio saranno più facili con 2 persone. Se necessario, chiedere assistenza professionale.

**Attenzione**: posizionare tutte le parti su una superficie piana. Posizionare una coperta morbida o simile sotto per proteggere da graffi o macchie. Evitare di trascinare o far scivolare i componenti sul pavimento.

**Attenzione**: controllare regolarmente tutti i raccordi e i dispositivi di fissaggio per assicurarsi che siano sicuri e per prevenire incidenti. Se alcune parti sono mancanti, rotte, danneggiate o usurate, interrompere l'uso del prodotto fino a quando non siano state eseguite le riparazioni utilizzando parti autorizzate dalla fabbrica.

**Attenzione**: non consentire ai bambini di arrampicarsi sui mobili poiché ciò potrebbe causare ribaltamenti e gravi lesioni personali. Montare i mobili lontano dalla portata dei bambini.

**Attenzione**: non posizionare i mobili vicino a fonti di fuoco o oggetti ad alta temperatura per evitare il rischio di incendio

**Attenzione**: pulire i mobili con un panno umido o alcol, evitare di utilizzare detergenti contenenti sostanze chimiche corrosive.

**Attenzione**: questo prodotto è dotato di un dispositivo antiribaltamento. Assicurarsi di installare questo dispositivo per prevenire lesioni inutili causate dal ribaltamento.

[ES]

**Advertencia**: Lea estas instrucciones completamente antes de comenzar el montaje. Compruebe que tiene todos los componentes y herramientas que se enumeran en las páginas. Conserve las instrucciones para consultarlas más adelante. El montaje de algunas partes será más sencillo con 2 personas. Busque ayuda profesional si es necesario.

**Advertencia**: Coloque todas las piezas sobre una superficie plana. Coloque una manta suave o algo similar debajo para protegerlas de rayones o manchas. Evite arrastrar o deslizar los componentes por el piso.

**Advertencia**: Verifique regularmente todos los accesorios y fijaciones para asegurarse de que estén seguros y evitar accidentes. Si falta alguna pieza, está rota, dañada o desgastada, deje de usar el producto hasta que se hayan realizado las reparaciones con piezas autorizadas de fábrica.

**Advertencia**: No permita que los niños se suban a los muebles, ya que esto puede provocar que se vuelquen y lesiones personales graves. Monte los muebles fuera del alcance de los niños.

**Advertencia**: No coloque los muebles cerca de fuentes de fuego u objetos de alta temperatura para evitar el riesgo de incendio.

**Advertencia**: Limpie los muebles con un paño húmedo o alcohol, evite usar agentes de limpieza que contengan químicos corrosivos.

**Advertencia**: Este producto está equipado con un dispositivo antivuelco. Asegúrese de instalar este dispositivo para evitar lesiones innecesarias causadas por vuelcos.

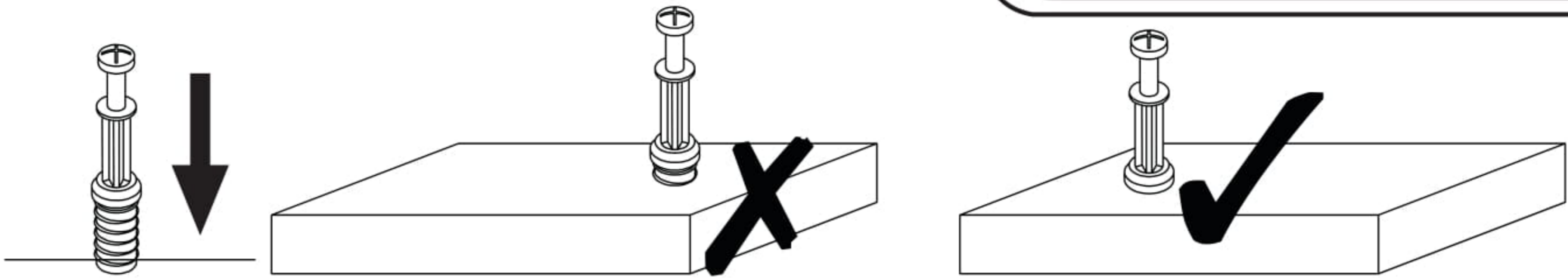

**EN\_QUICKFIT:** Tighten quickfit until shoulder is flush with panel. Do not overtighten or undertighten.

**FR\_RACCORD RAPIDE:** Faites serrer le raccord rapide jusqu'à ce que l'épaulement soit parfaitement encastré dans le panneau. Il ne faut ni trop serrer ni insuffisamment serrer.

**ES\_QUICKFIT:** Apriete quickfit hasta que el hombro se descargue con el panel. NO lo sobreapriete ni lo apriete poco.

**DE\_QUICKFIT:** Ziehen Sie den Quickfit fest, bis die Schulter mit der Platte bündig ist. Bitte nicht zu fest oder zu schwach anziehen.

**IT\_MONTAGGIO RAPIDO:** Stringere il montaggio rapido fino a quando la spalla è a filo con il pannello, non stringere troppo o troppo poco.

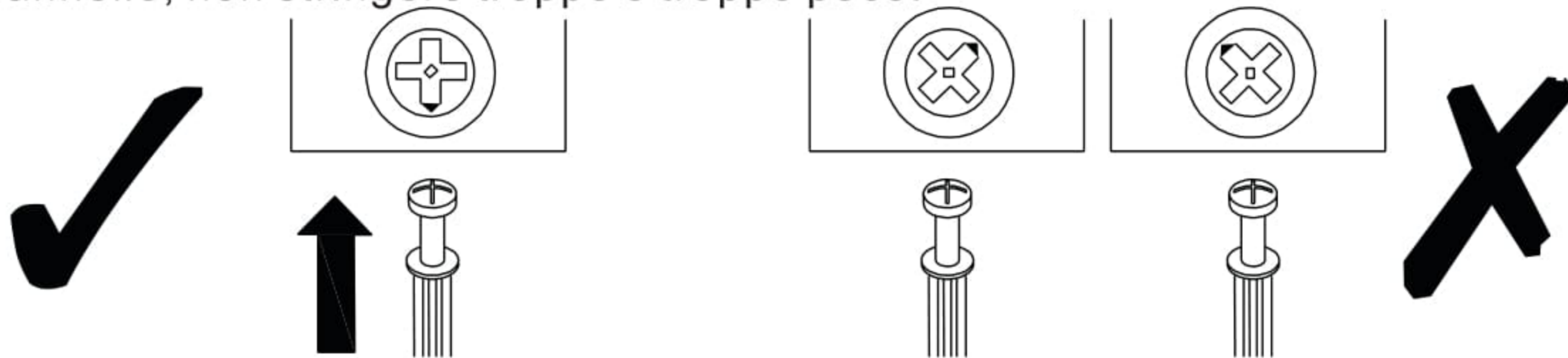

**EN\_CAM LOCK:** When fitting cam lock, ensure starting position is correct before you insert connecting quickfit.

**FR\_SERRURE BATTEUSE:** Avant d'insérer la serrure batteuse, veillez à la bonne orientation avant d'insérer le raccord rapide.

**ES\_CIERRE DE LA CÁMARA:** Cuando instale el cierre de la cámara, asegúrese de que la posición de inicio es correcta antes de que inserte el quickfit conector.

**DE\_CAM-LOCK:** Achten Sie bei der Montage des Cam-Locks auf die richtige Ausgangsposition, bevor Sie den Quickfit einsetzen.

**IT\_BLOCCAGGIO A CAMMA:** Quando si monta il bloccaggio a camma, assicurarsi che la posizione iniziale sia corretta prima di inserire il montaggio rapido di collegamento.

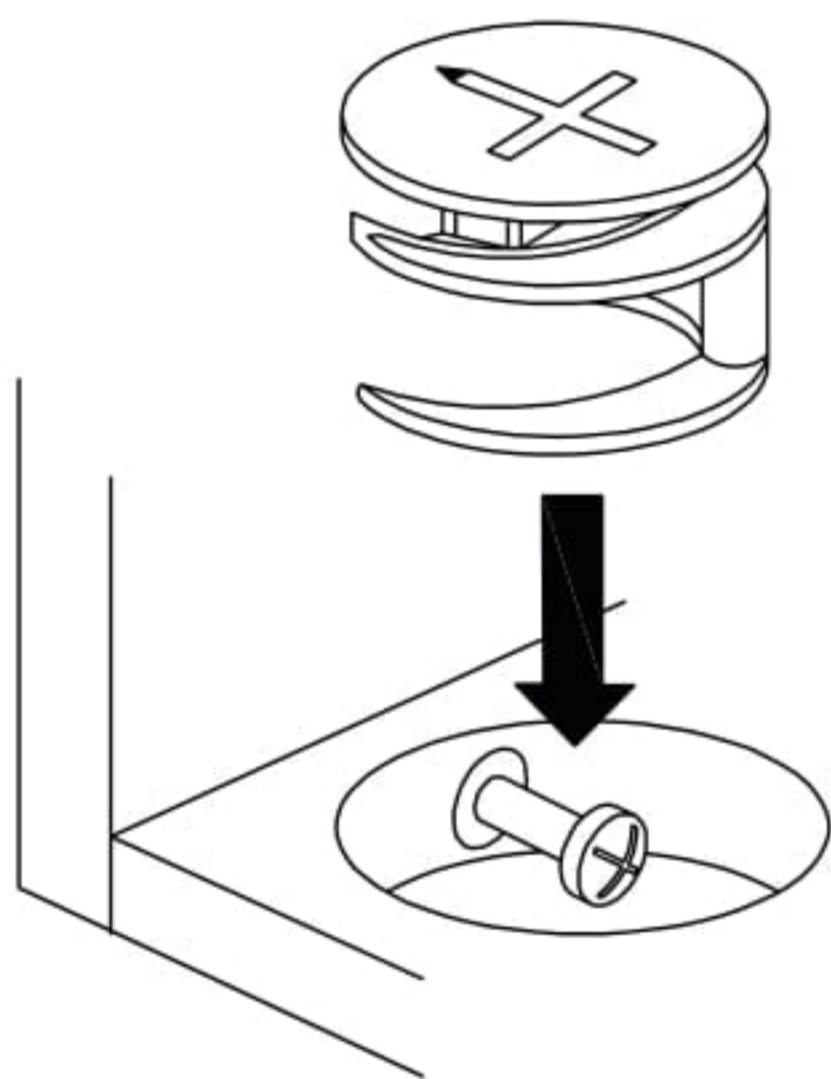

**EN\_Quickfit head** should be in the centre of the cam lock when the two panels are joined.

Cam lock should be inserted before quickfit.

**FR\_**Lorsque les deux panneaux sont assemblés, la tête du raccord rapide doit reposer au centre de la serrure batteuse. Il faut insérer la serrure batteuse avant le raccord rapide.

**ES\_**El cabezal del quickfit debe estar en el centro del cierre de la cámara cuando se unan los dos paneles.

Se debe insertar el cierre de la cámara antes que el quickfit.

**DE\_**Der Quickfit-Kopf sollte sich in der Mitte des Cam-Locks befinden, wenn die beiden Platten zusammengefügt sind.

Der Cam-Lock sollte vor dem Quickfit eingesetzt werden.

**IT\_**La testa del montaggio rapido deve trovarsi al centro del bloccaggio a camma quando i due pannelli sono uniti.

Il Bloccaggio a Camma deve essere inserito prima del montaggio rapido.

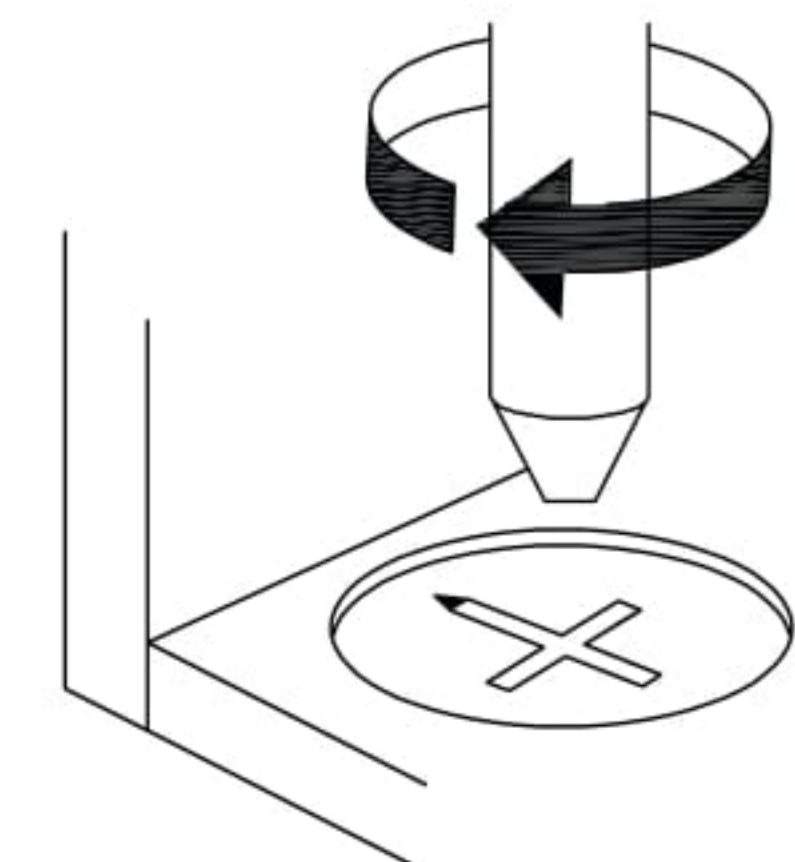

**EN\_**Turn cam lock clockwise to tighten.

**FR\_**Faites tourner la serrure batteuse dans le sens des aiguilles d'une montre pour la resserrer.

**ES\_**Gire el cierre de la cámara en sentido horario para apretarlo.

**DE\_**Drehen Sie den Cam-Lock im Uhrzeigersinn, um ihn festzuziehen.

**IT\_**Ruotare il bloccaggio a camma in senso orario per stringere.

**EN** It may be necessary to adjust the hinges so that the doors align. Use the instructions below as a guide.

**FR** Il est parfois nécessaire d'ajuster les charnières pour un meilleur alignement des portes. Servez-vous des instructions ci-dessous comme guide.

**ES** Puede que sea necesario ajustar los quicios de forma que se alineen las puertas. Use las instrucciones que aparecen debajo como guía.

**DE** Möglicherweise müssen Sie die Scharniere so einstellen, dass die Türen ausgerichtet sind. Verwenden Sie die nachstehenden Anweisungen als Leitfaden.

**IT** Potrebbe essere necessario regolare le cerniere in modo che le porte siano allineate. Per fare ciò attenersi alle istruzioni sottostanti.

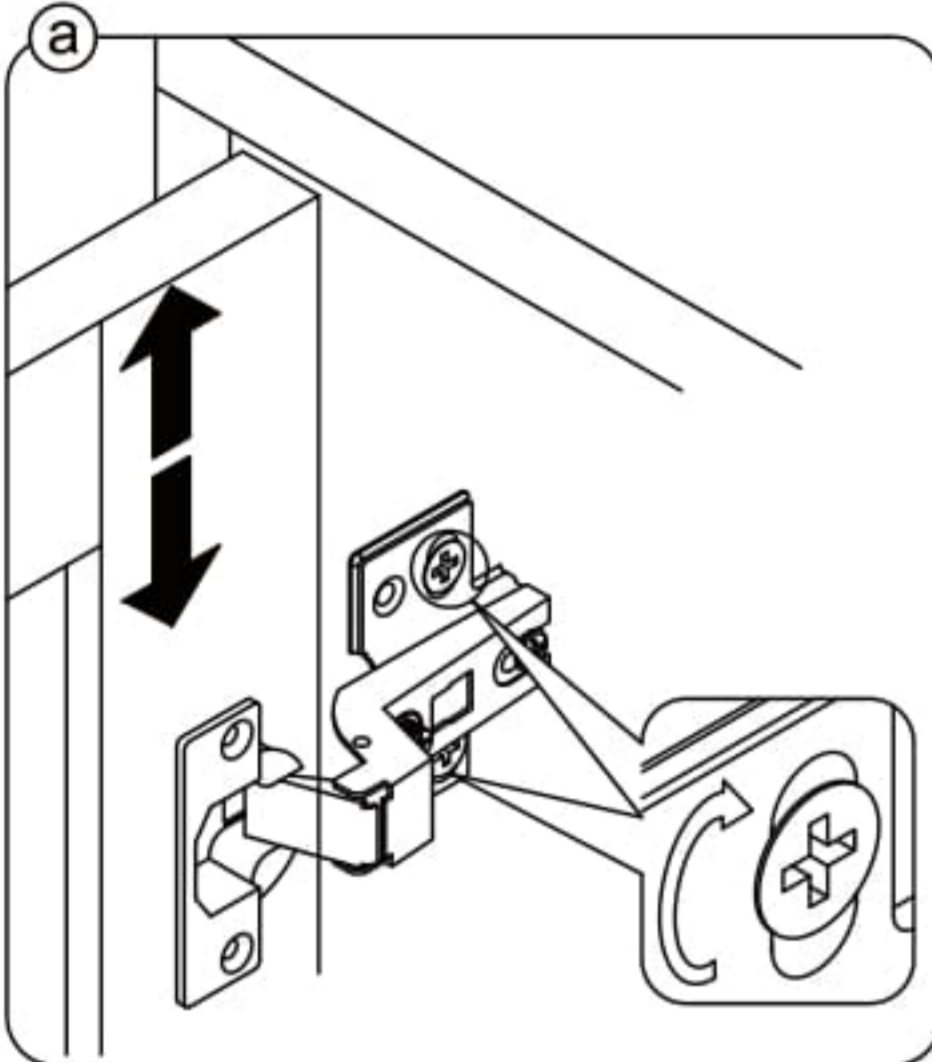

**EN** To adjust the door vertically loosen the screw as shown and move up and down as needed.

**FR** Si vous souhaitez régler la porte **verticalement**, desserrez la vis comme indiqué et déplacez la porte de haut en bas selon les besoins.

**ES** Para ajustar la puerta **verticalmente** afloje el tornillo tal y como se muestra y muévalo hacia arriba o hacia abajo según sea necesario.

**DE** Um die Tür **vertikal** auszurichten, lösen Sie die Schraube wie abgebildet und bewegen Sie sie nach Bedarf nach oben oder nach unten.

**IT** Per allineare la porta **verticalmente** allentare la vite come mostrato e spostarla in alto o in basso secondo necessità.

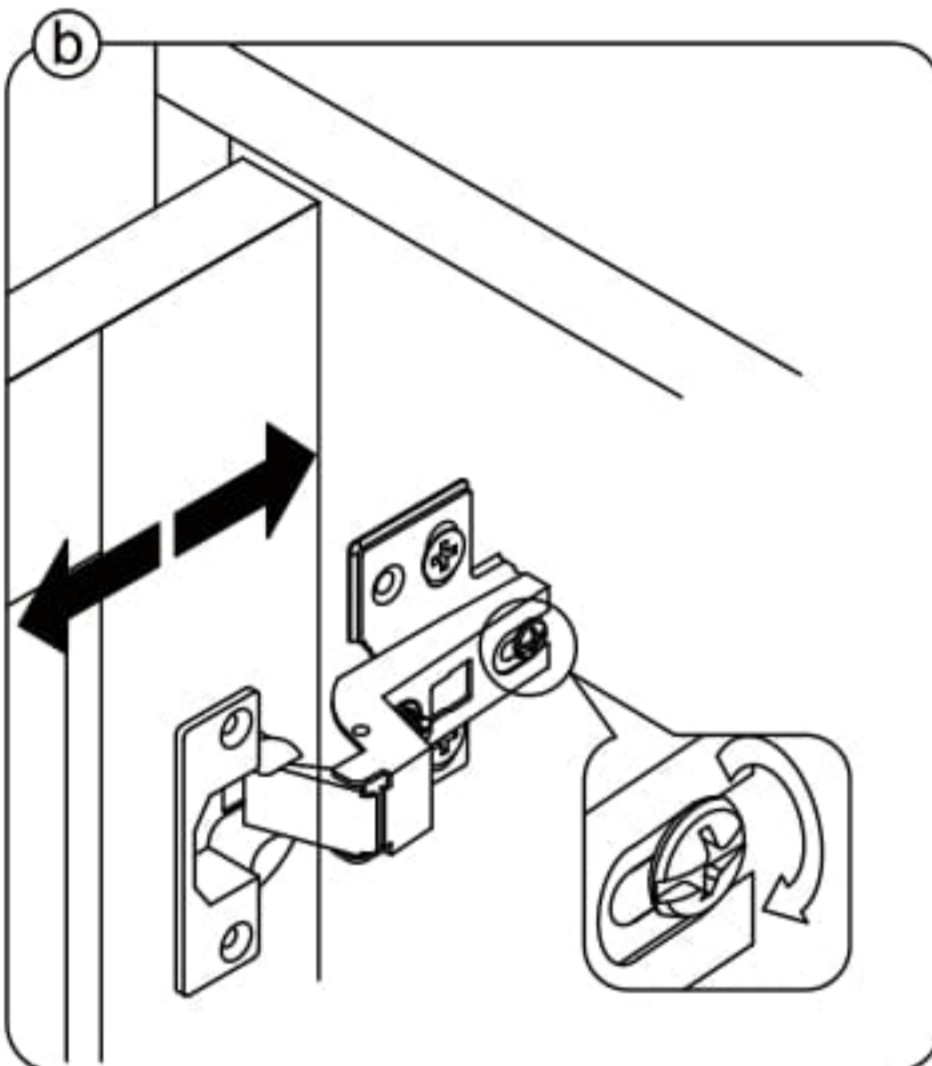

**EN** To adjust the gap from the door to the main frame turn the screw clockwise or anti-clockwise as needed.

**FR** Si vous souhaitez ajuster **l'écart** entre la porte et le cadre principal, tournez la vis dans le sens des aiguilles d'une montre ou dans le sens inverse, si nécessaire.

**ES** Para ajustar el **espacio** desde la puerta al marco principal, gire el tornillo en sentido horario o antihorario, según se necesite.

**DE** Um den **Abstand** von der Tür zum Hauptrahmen auszurichten, drehen Sie die Schraube je nach Bedarf im oder gegen den Uhrzeigersinn.

**IT** Per regolare lo **spazio** tra la porta e il telaio principale, avvitare o svitare la vite secondo necessità.

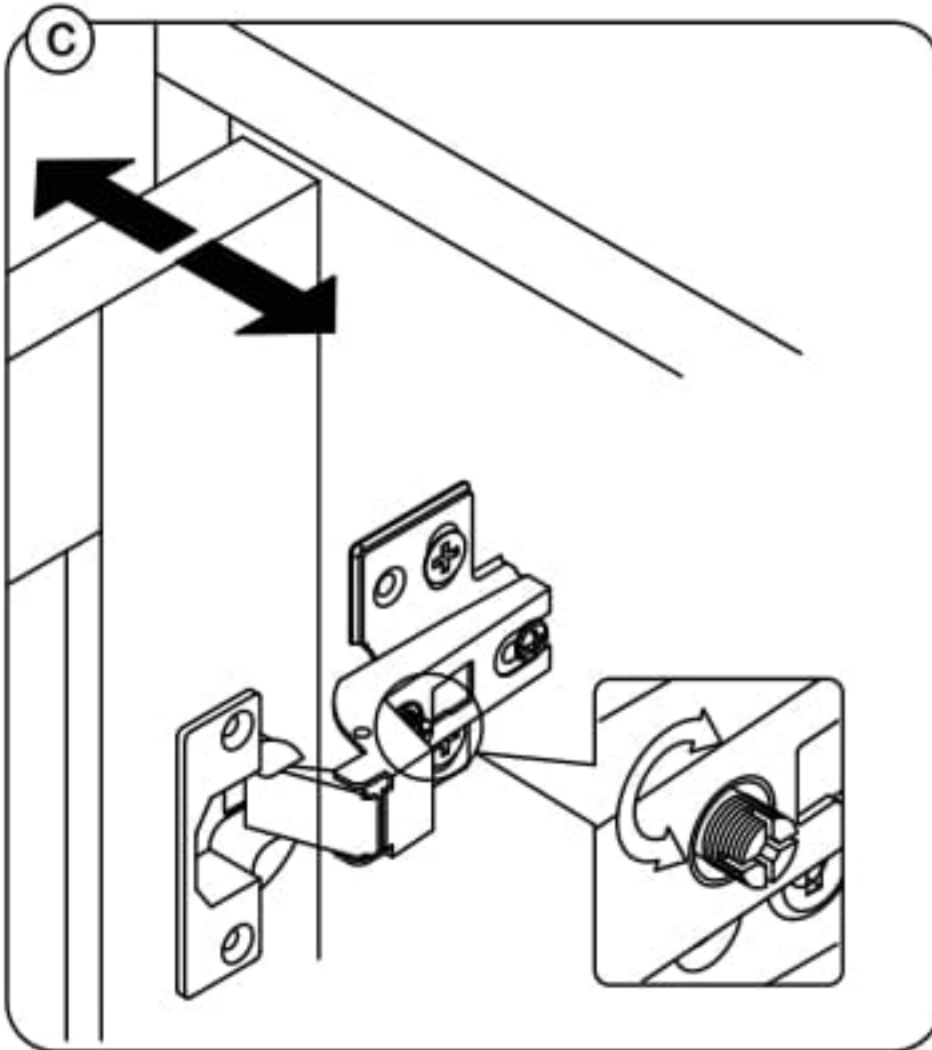

**EN** To adjust the door laterally adjust the screw as shown by turning clockwise or anti-clockwise.

**FR** Si vous souhaitez ajuster la porte **latéralement**, ajustez la vis comme indiqué en tournant dans le sens des aiguilles d'une montre ou dans le sens inverse des aiguilles d'une montre.

**ES** Para ajustar la puerta **lateralmente** ajuste el tornillo tal y como se muestra girándolo en sentido horario y antihorario.

**DE** Um die Tür **seitlich** auszurichten, stellen Sie bitte die Schraube wie abgebildet durch Drehen im oder gegen den Uhrzeigersinn ein.

**IT** Per allineare la porta **lateralmente** regolare la vite come mostrato, avvitandola o svitandola.

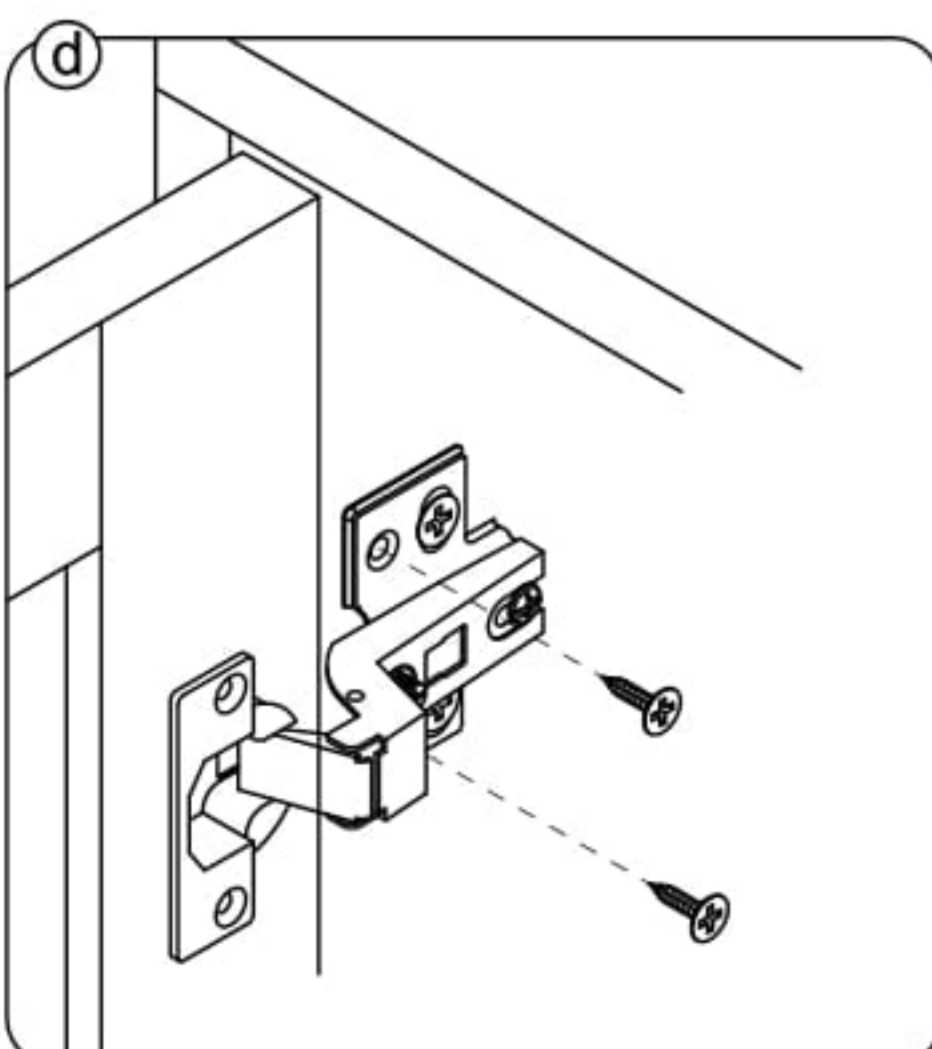

**EN** Please fix other screws

**FR** Merci de serrer les autres vis.

**ES** Fije los demás tornillos

**DE** Befestigen Sie bitte die anderen Schrauben

**IT** Fissare le altre viti

**BOX-1/2**

**BOX-2/2**

**PACKING DETAILS: TOTAL 2 BOXES**

| NO. | PARTS | QTY |
|-----|-------|-----|
| ②   |       | 1   |
| ③   |       | 1   |
| ⑥   |       | 1   |
| ⑦   |       | 1   |
| ⑬   |       | 1   |
| ⑭   |       | 1   |
| ⑮   |       | 1   |
| ⑰   |       | 1   |
| ⑱   |       | 1   |
| ⑲   |       | 1   |
| ⑳   |       | 1   |
| ㉑   |       | 1   |
| ㉒   |       | 1   |
| ㉓   |       | 1   |
| ㉔   |       | 1   |
| ㉕   |       | 1   |
| ㉖   |       | 1   |
| ㉗   |       | 1   |
| ㉘   |       | 1   |
| ㉙   |       | 1   |
| ㉚   |       | 1   |
| ㉛   |       | 1   |
| ㉜   |       | 1   |
| ㉝   |       | 1   |
| ㉞   |       | 1   |
| ㉟   |       | 1   |
| ㊱   |       | 1   |
| ㊲   |       | 1   |
| ㊳   |       | 1   |
| ㊴   |       | 1   |
| ㊵   |       | 1   |
| ㊶   |       | 1   |
| ㊷   |       | 1   |
| ㊸   |       | 1   |
| ㊹   |       | 1   |
| ㊺   |       | 1   |
| ㊻   |       | 1   |
| ㊼   |       | 1   |
| ㊽   |       | 1   |
| ㊾   |       | 1   |
| ㊿   |       | 1   |
| 1   |       | 1   |
| 2   |       | 1   |
| 3   |       | 1   |
| 4   |       | 1   |
| 5   |       | 1   |
| 6   |       | 1   |
| 7   |       | 1   |
| 8   |       | 1   |
| 9   |       | 1   |
| 10  |       | 1   |
| 11  |       | 1   |
| 12  |       | 1   |
| 13  |       | 1   |
| 14  |       | 1   |
| 15  |       | 1   |
| 16  |       | 1   |
| 17  |       | 1   |
| 18  |       | 1   |
| 19  |       | 1   |
| 20  |       | 1   |
| 21  |       | 1   |
| 22  |       | 1   |
| 23  |       | 1   |
| 24  |       | 1   |
| 25  |       | 1   |
| 26  |       | 1   |
| 27  |       | 1   |
| 28  |       | 1   |
| 29  |       | 1   |
| 30  |       | 1   |
| 31  |       | 1   |
| 32  |       | 1   |
| 33  |       | 1   |
| 34  |       | 1   |
| 35  |       | 1   |
| 36  |       | 1   |
| 37  |       | 1   |
| 38  |       | 1   |
| 39  |       | 1   |
| 40  |       | 1   |
| 41  |       | 1   |
| 42  |       | 1   |
| 43  |       | 1   |
| 44  |       | 1   |
| 45  |       | 1   |
| 46  |       | 1   |
| 47  |       | 1   |
| 48  |       | 1   |
| 49  |       | 1   |
| 50  |       | 1   |

| NO. | PARTS | QTY |
|-----|-------|-----|
| ①   |       | 1   |
| ④   |       | 2   |
| ⑤   |       | 1   |
| ⑧   |       | 2   |
| ⑨   |       | 1   |
| ⑩   |       | 1   |
| ⑪   |       | 1   |
| ⑫   |       | 1   |
| ⑱   |       | 3   |
| ㉙   |       | 3   |



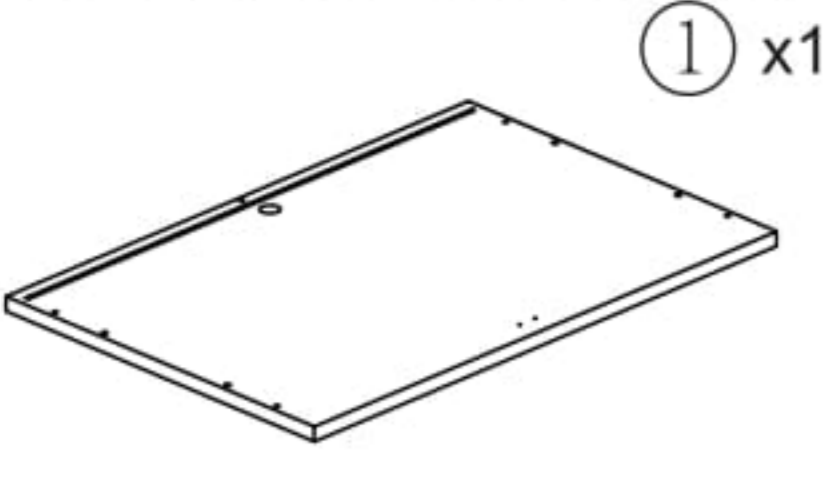
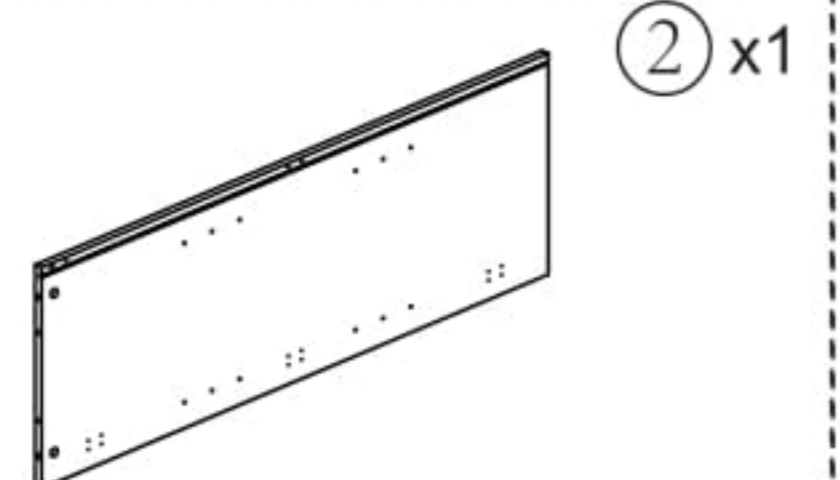
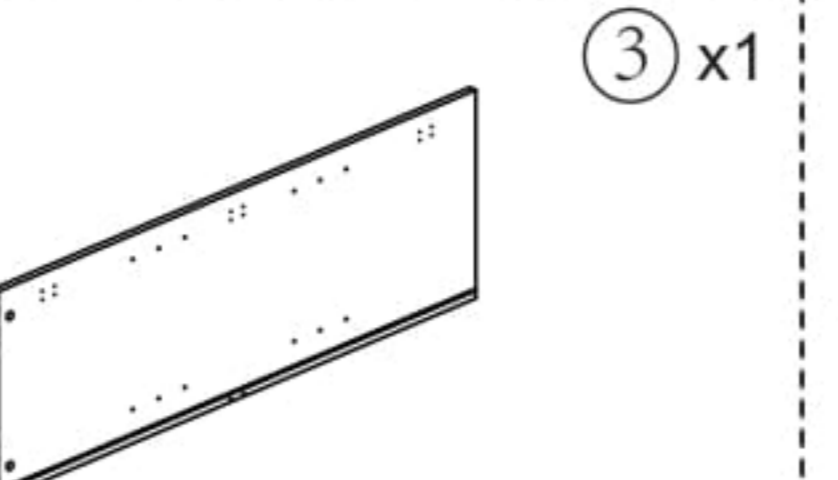
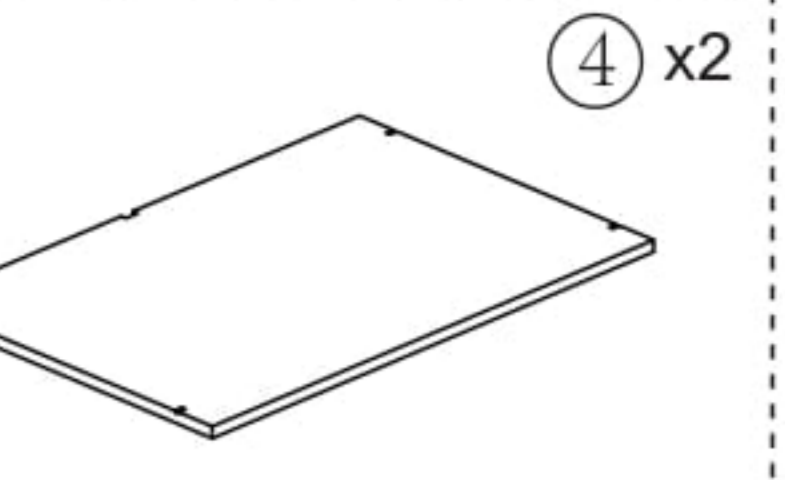
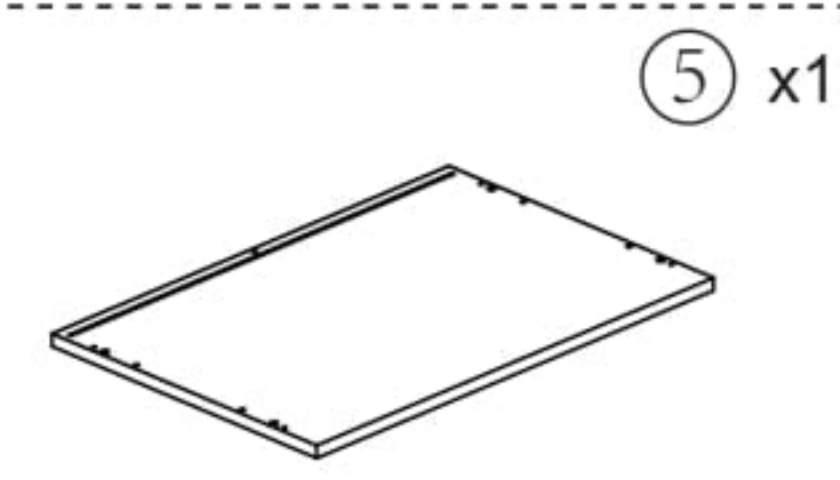
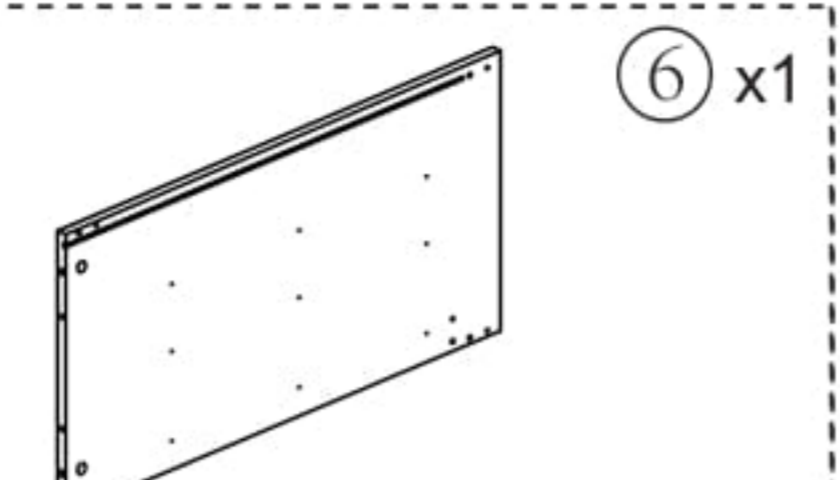
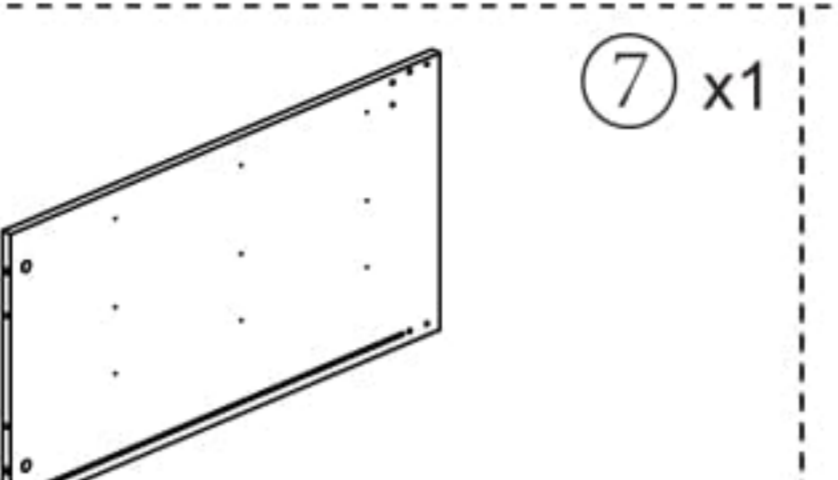
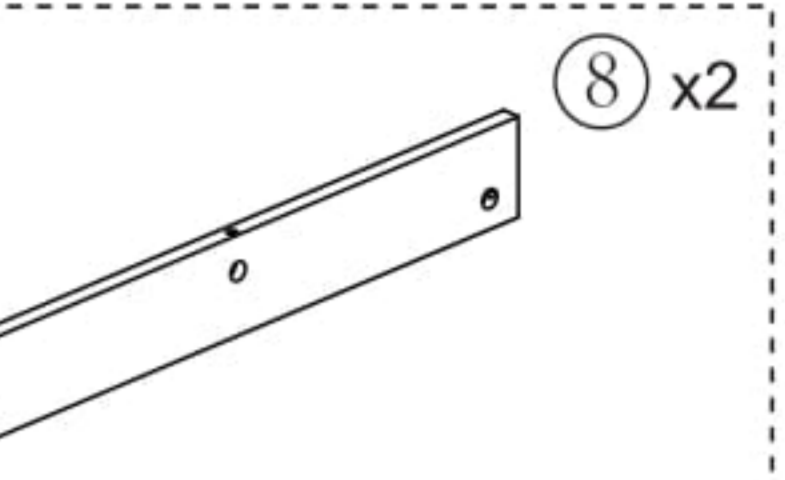
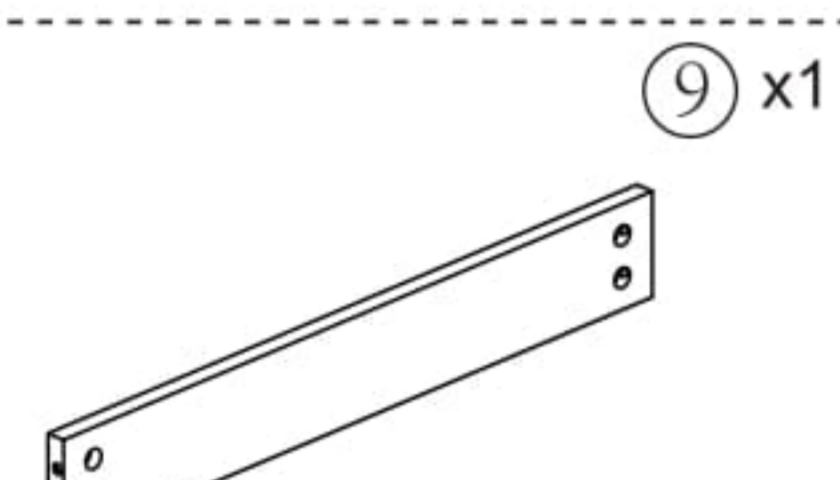
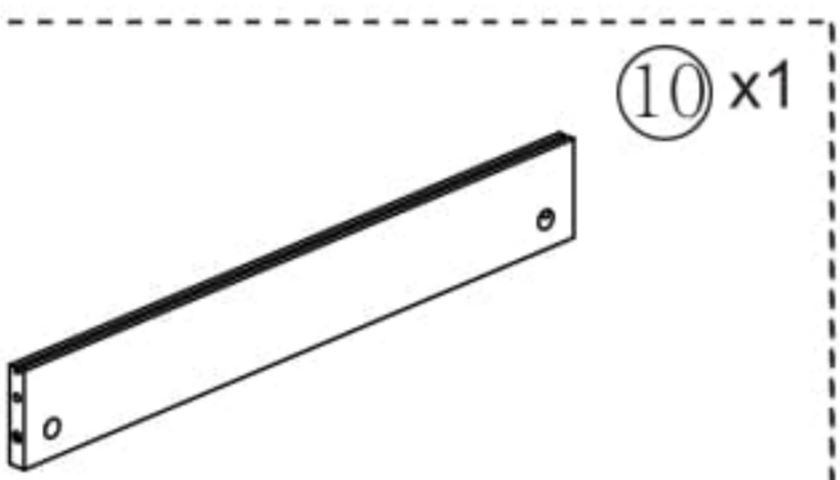
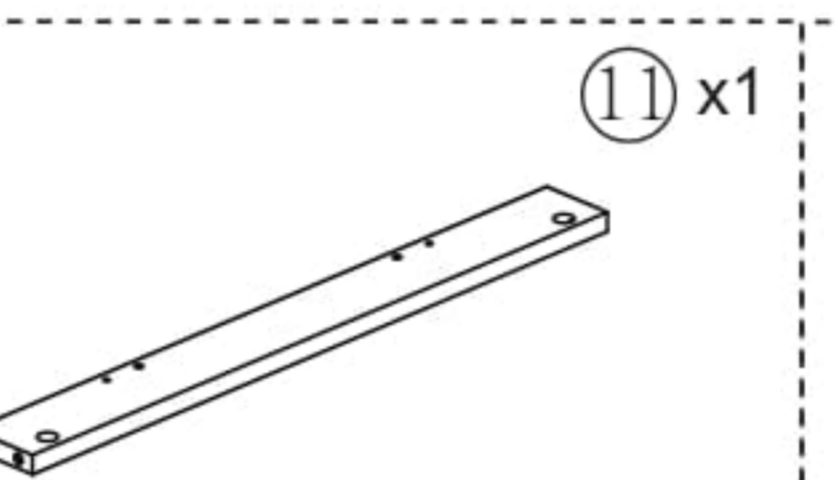
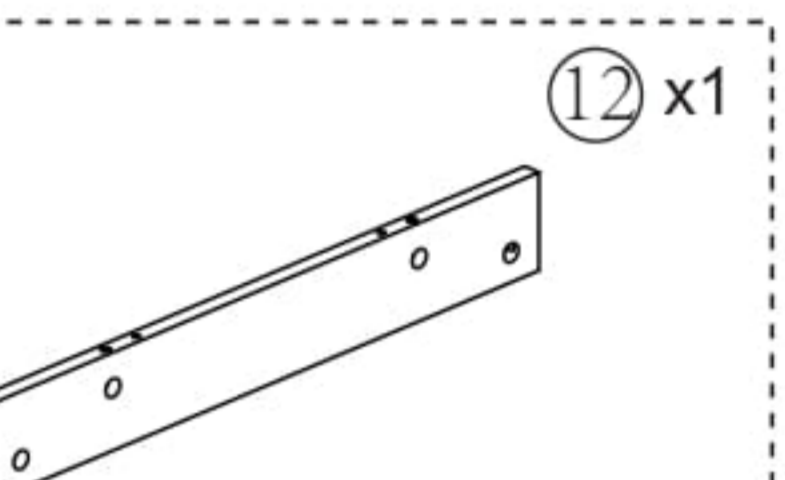
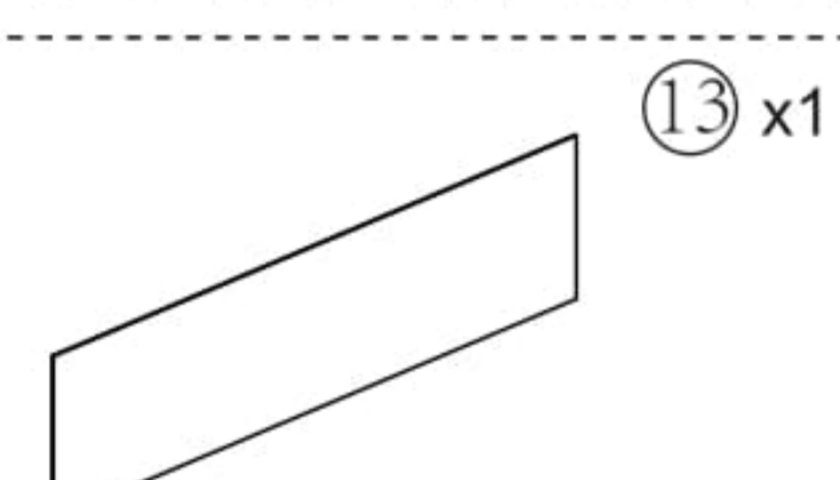
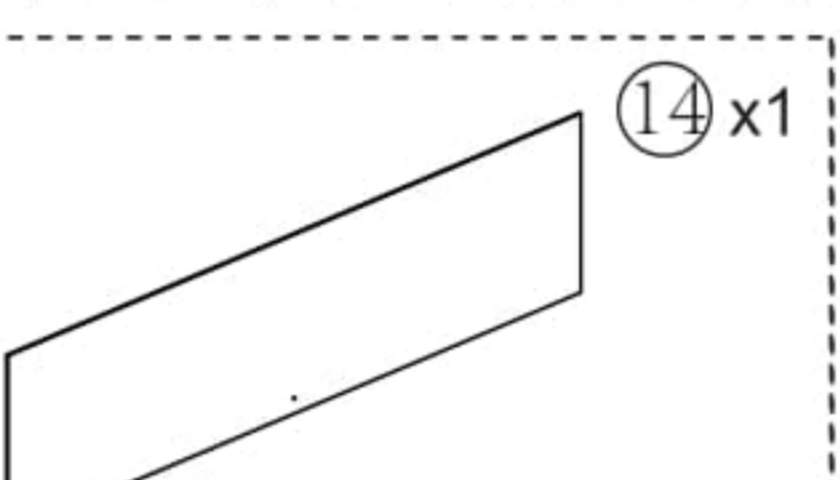
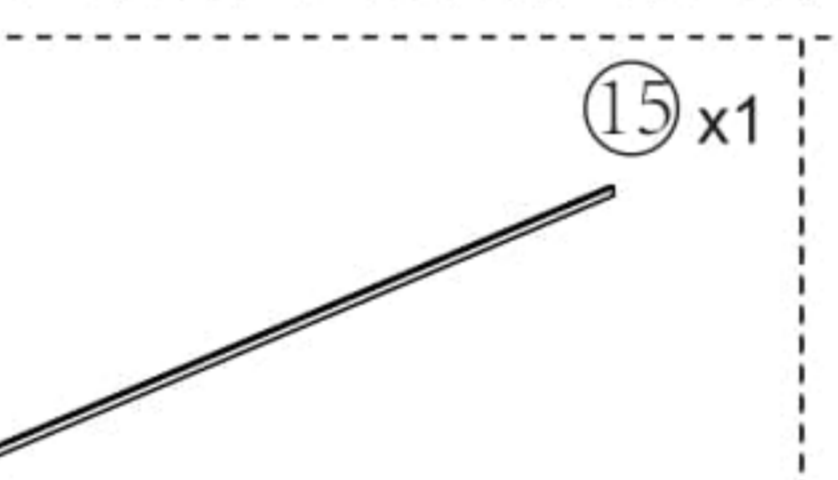
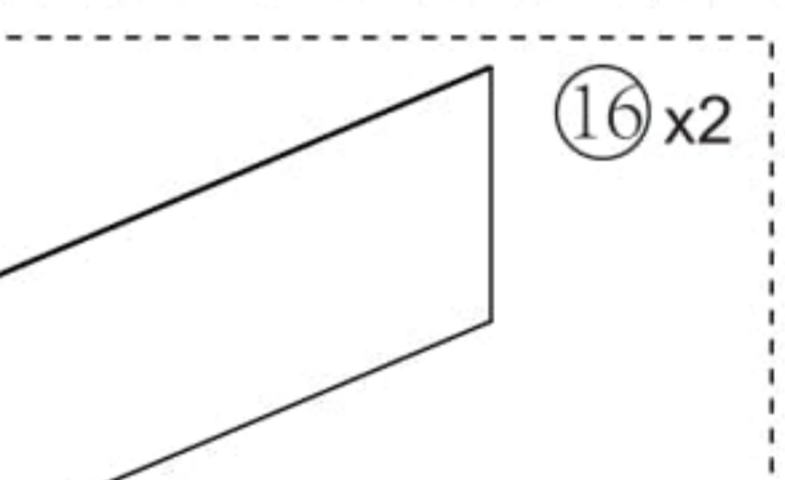
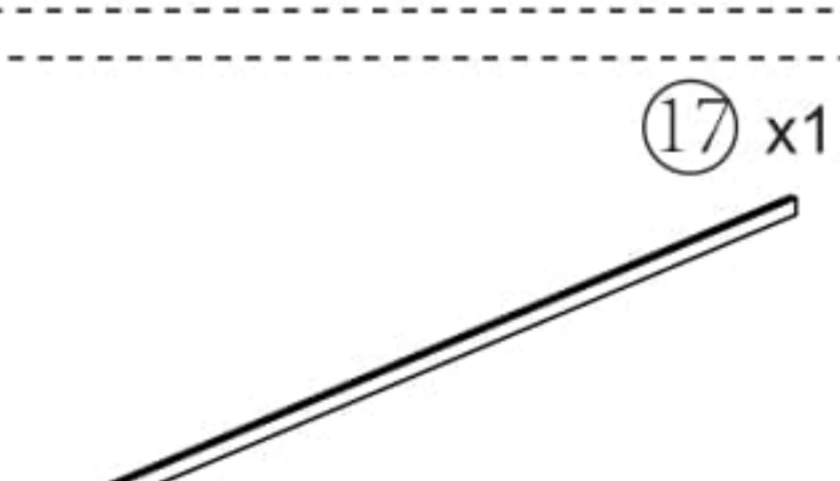
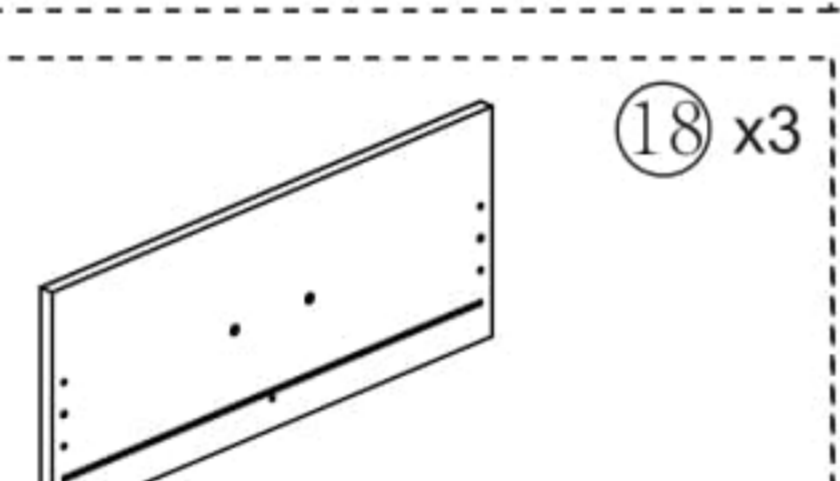
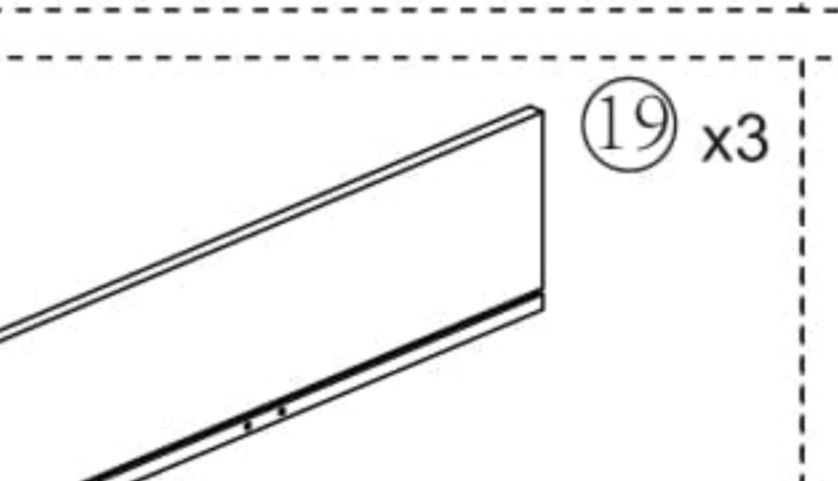
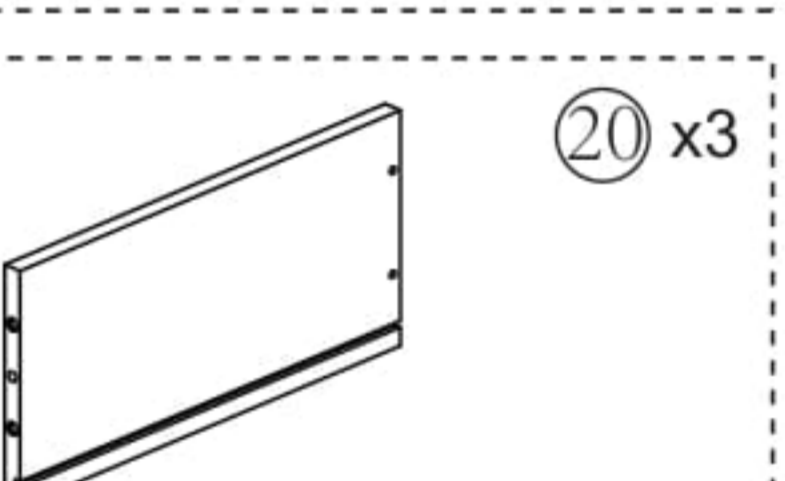
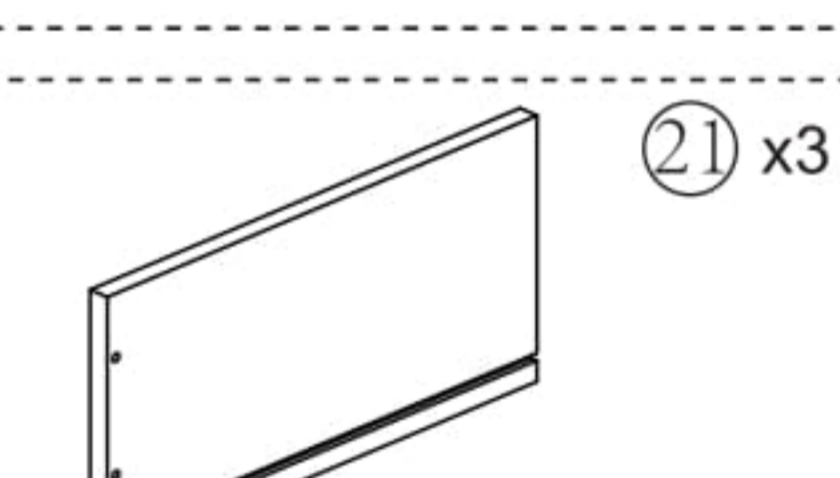
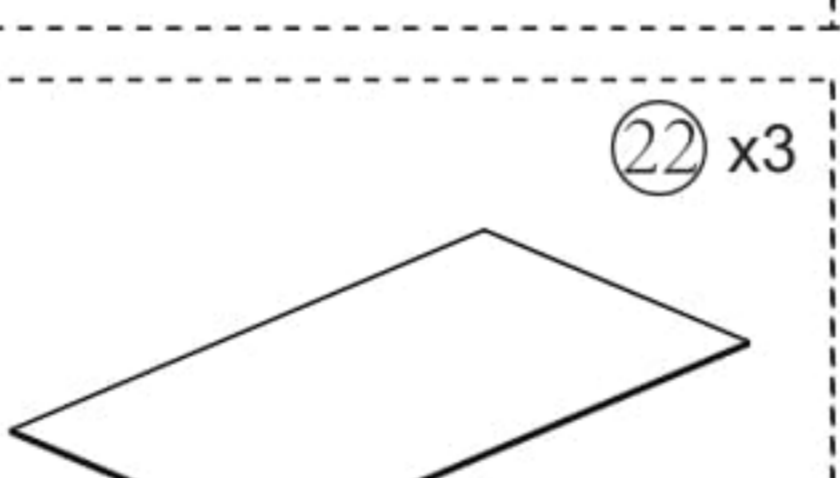
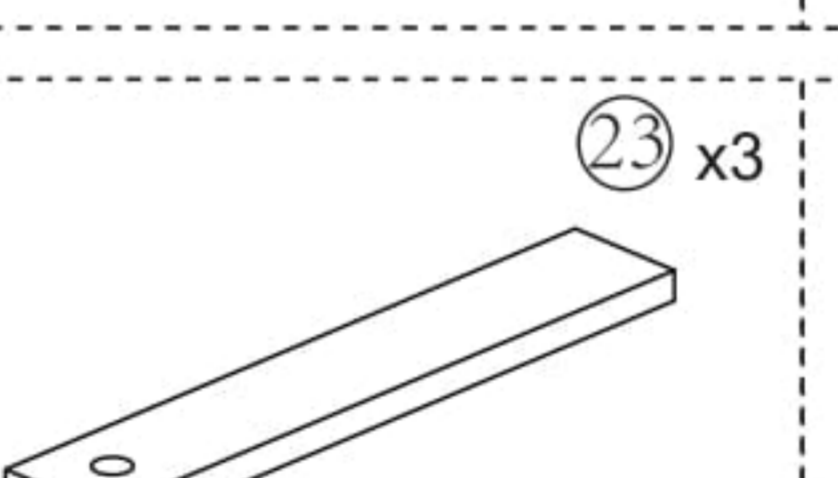
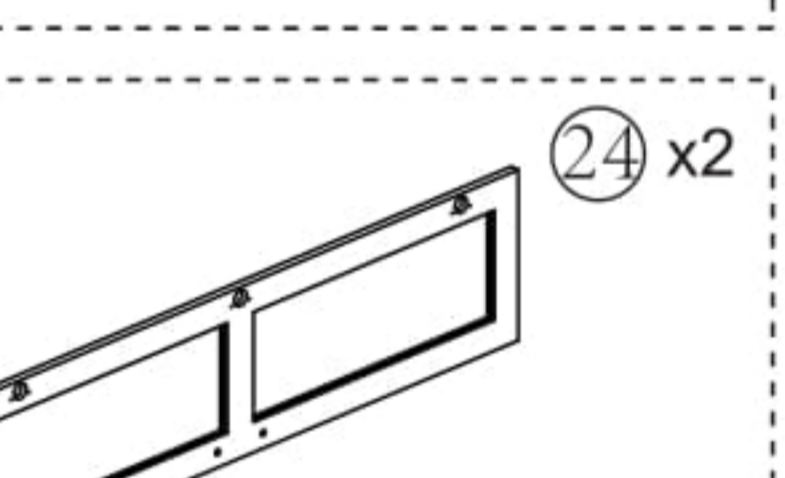

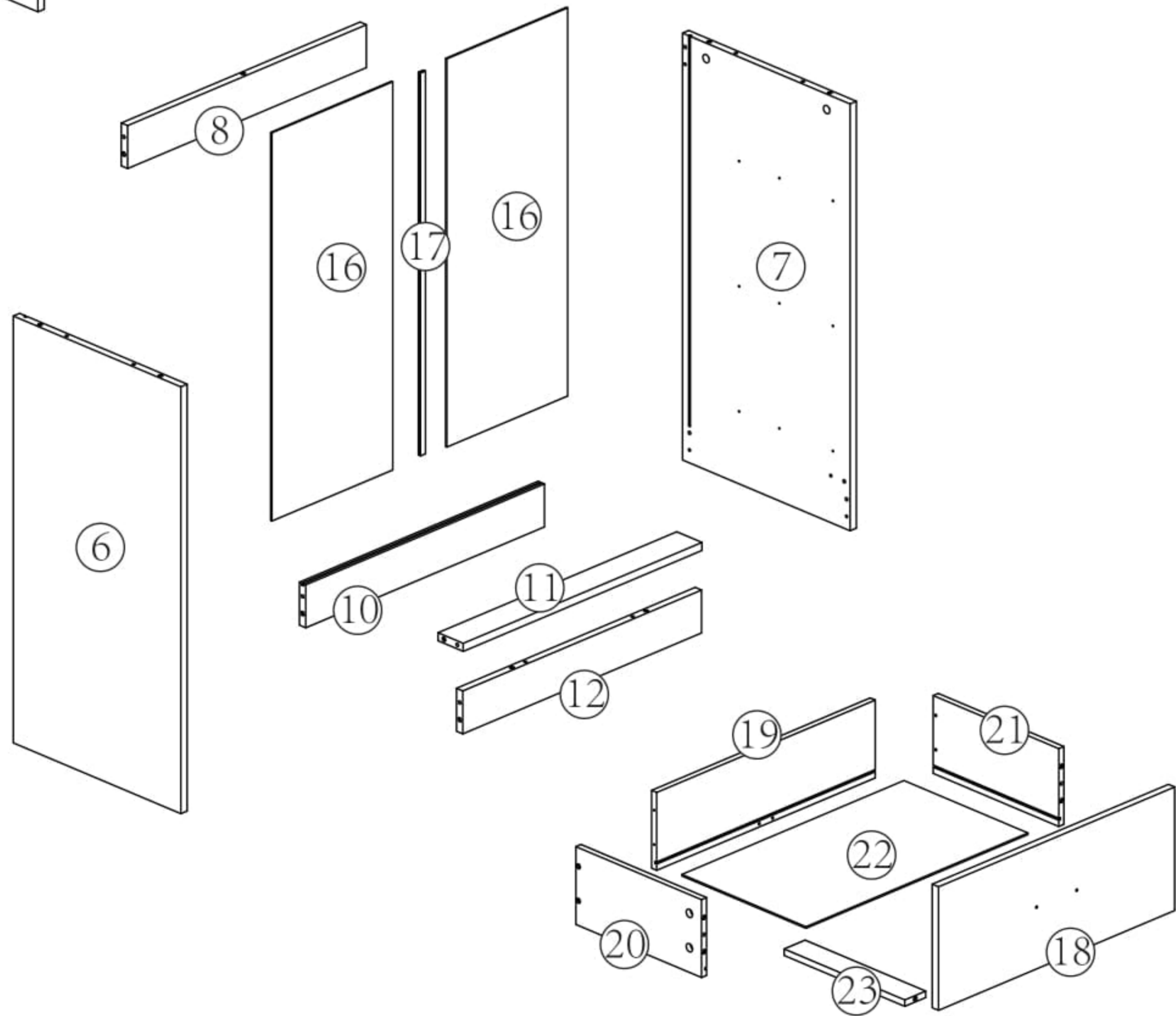
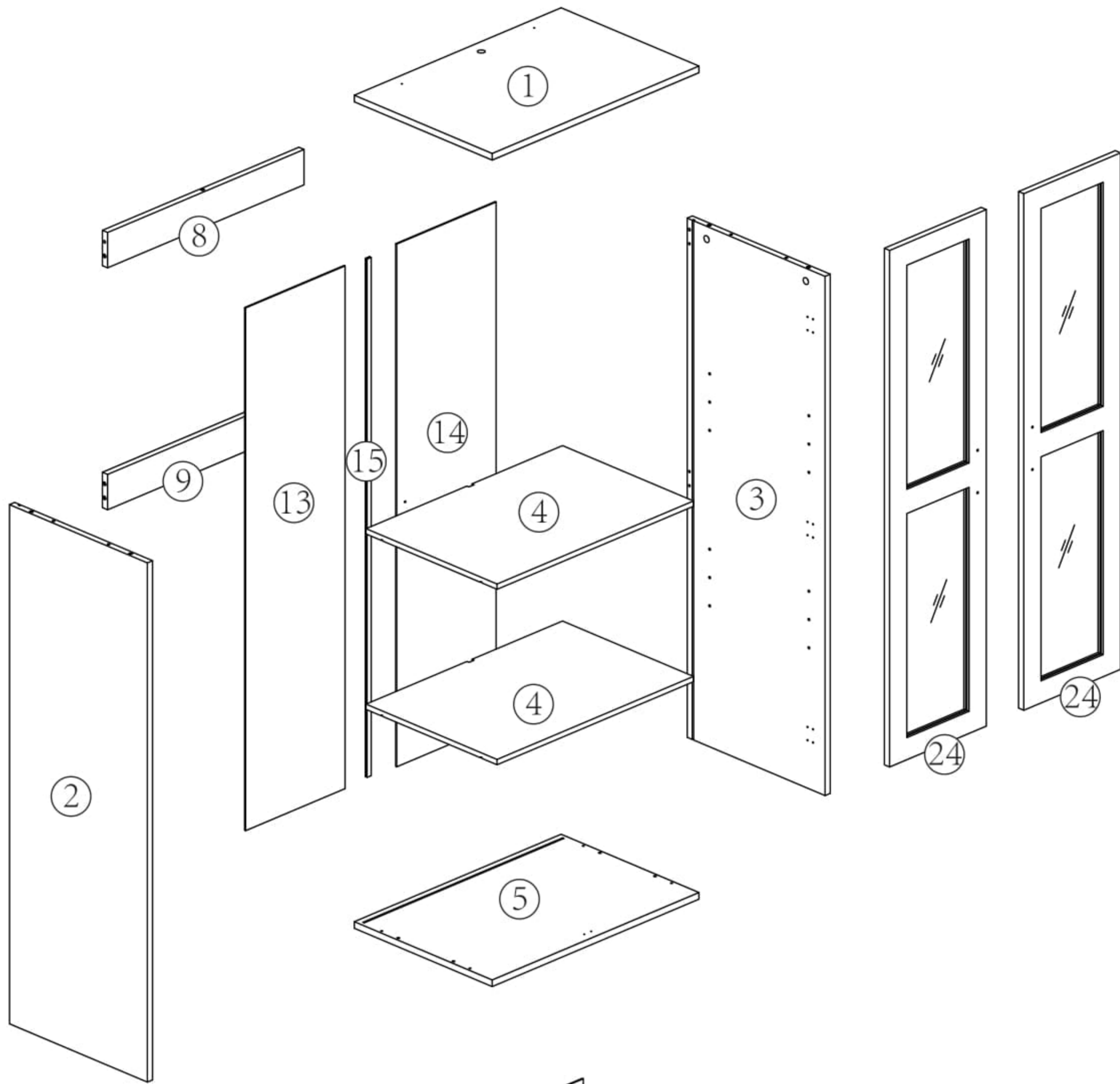





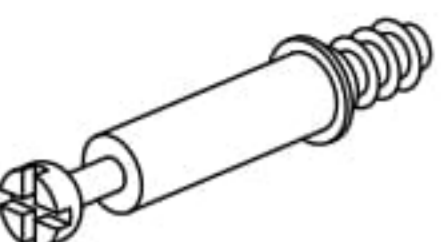

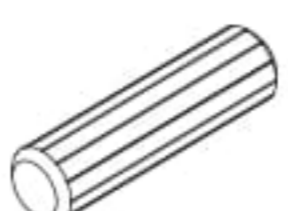
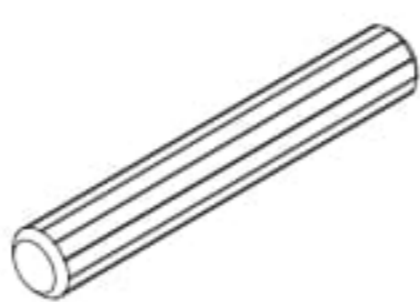
| NO. | PARTS | QTY |
|-----|-------|-----|
| ⑳   |       | 3   |
| ㉑   |       | 3   |
| ㉓   |       | 3   |
|     |       |     |

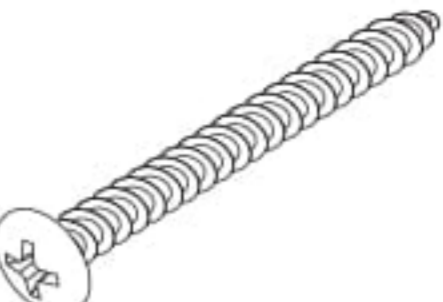
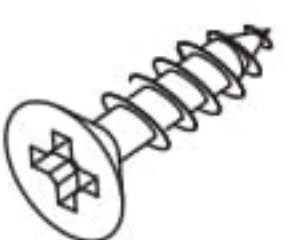
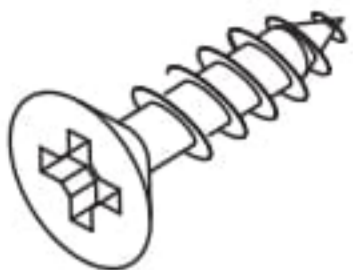
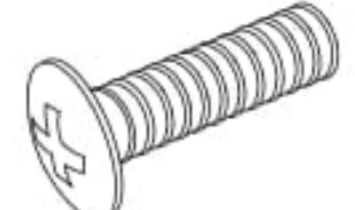
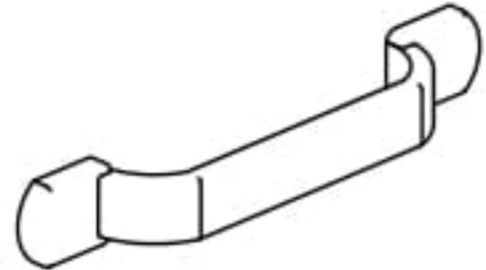
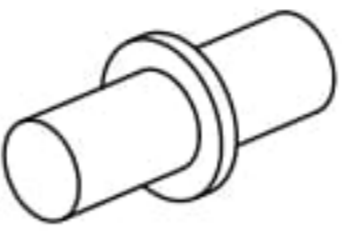
|  |   |  |   |
|--|---|--|---|
|  <p>① x1<br/>599x398x15mm</p>   |  <p>② x1<br/>1175x397x15mm</p>  |  <p>③ x1<br/>1175x397x15mm</p>  |  <p>④ x2<br/>565x355x12mm</p>    |
|  <p>⑤ x1<br/>599x398x15mm</p>   |  <p>⑥ x1<br/>795x397x15mm</p>   |  <p>⑦ x1<br/>795x397x15mm</p>   |  <p>⑧ x2<br/>568x80x15mm</p>     |
|  <p>⑨ x1<br/>568x80x15mm</p>   |  <p>⑩ x1<br/>568x80x15mm</p>   |  <p>⑪ x1<br/>568x60x15mm</p>   |  <p>⑫ x1<br/>568x80x15mm</p>    |
|  <p>⑬ x1<br/>1183x283x3mm</p> |  <p>⑭ x1<br/>1183x283x3mm</p> |  <p>⑮ x1<br/>1173x12x6mm</p>  |  <p>⑯ x2<br/>723x288x3mm</p>   |
|  <p>⑰ x1<br/>713x12x6mm</p>   |  <p>⑱ x3<br/>561x228x12mm</p> |  <p>⑲ x3<br/>519x145x12mm</p> |  <p>⑳ x3<br/>300x145x12mm</p>  |
|  <p>㉑ x3<br/>300x145x12mm</p> |  <p>㉒ x3<br/>527x295x3mm</p>  |  <p>㉓ x3<br/>287x50x12mm</p>  |  <p>㉔ x2<br/>1169x280x15mm</p> |

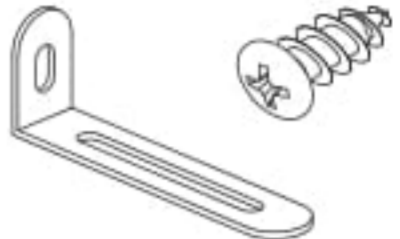
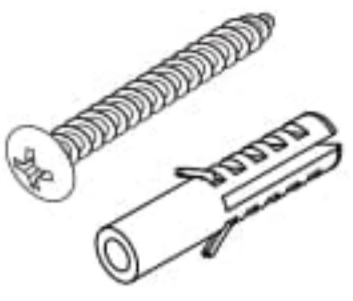
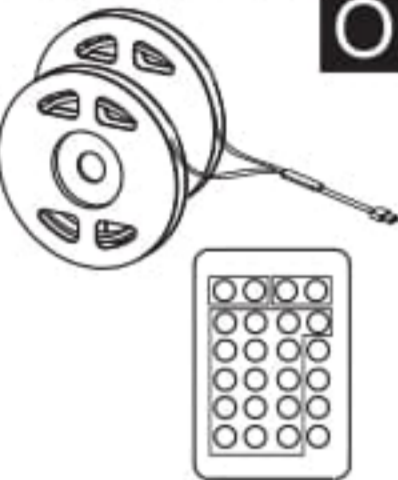

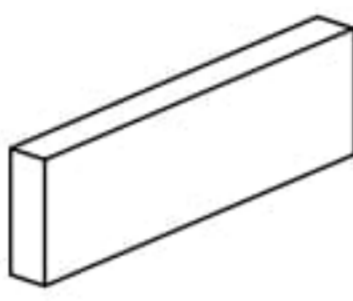
x3

# HARDWARE

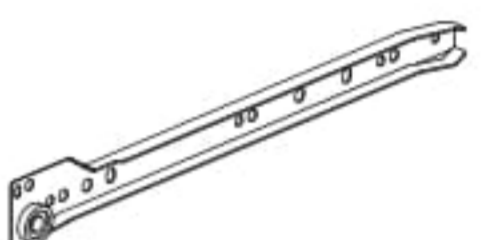
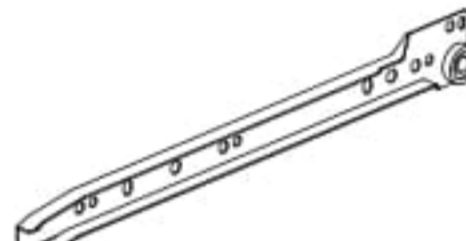
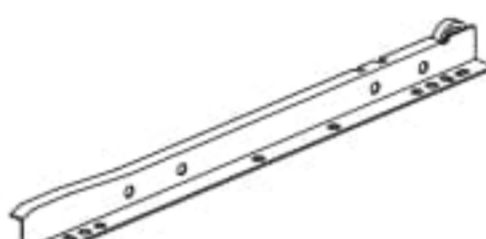
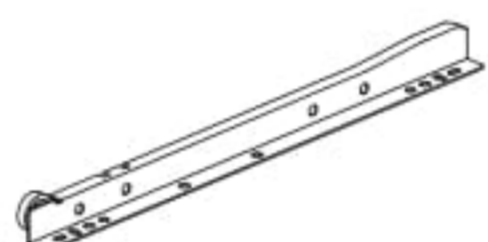
|  |  |  |  |  |  |  |
|--|--|--|--|--|--|--|
| <p><b>A x41</b></p>               | <p><b>B x41</b></p>               | <p><b>C x20</b><br/>6x30mm</p>    | <p><b>D x4</b><br/>6x50mm</p>  | <p><b>E x18</b><br/>4x35mm</p>  | <p><b>F x 4</b><br/>4x40mm</p>  | <p><b>G x36</b><br/>3x12mm</p>  |
| <p><b>H x36</b><br/>4x12mm</p>    | <p><b>I x10</b><br/>4x16mm</p>    | <p><b>J x5</b></p>                | <p><b>K x8</b></p>            | <p><b>L x10</b></p>             | <p><b>M x 2</b></p>             | <p><b>N x2</b></p>              |
| <p><b>O x1</b></p>                | <p><b>P x2</b></p>                | <p><b>Q x 8</b></p>               | <p><b>R x 1</b></p>            | <p><b>S x6</b></p>              | <p><b>T x16</b></p>             | <p><b>CL x3</b><br/>300mm</p>   |
| <p><b>CR x 3</b><br/>300mm</p>  | <p><b>DL x 3</b><br/>300mm</p>  | <p><b>DR x 3</b><br/>300mm</p>  |  |  |  |  |

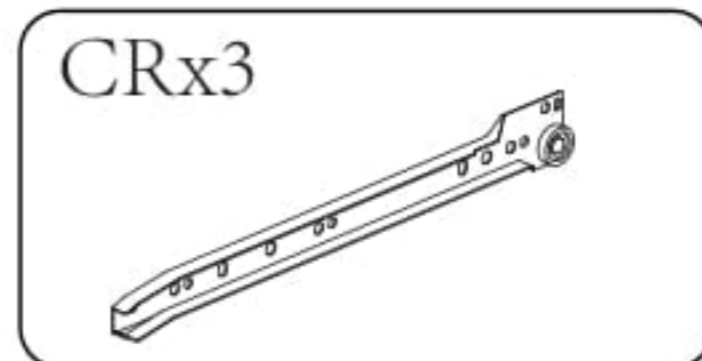
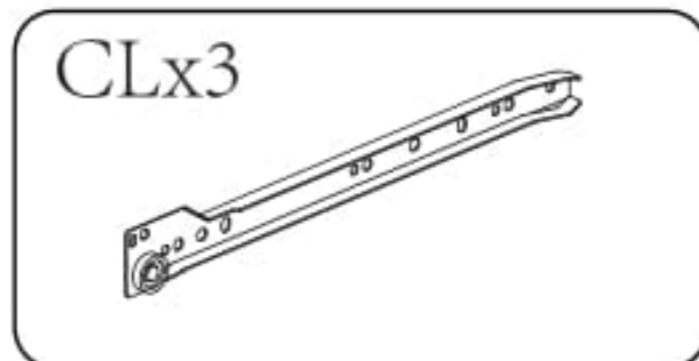
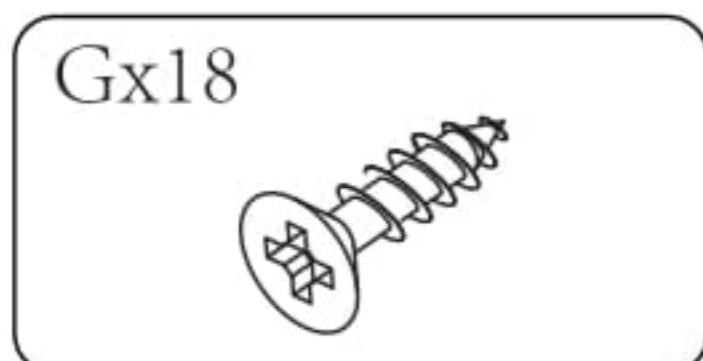
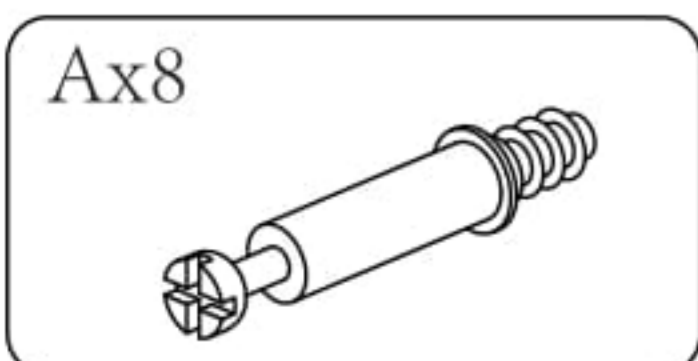
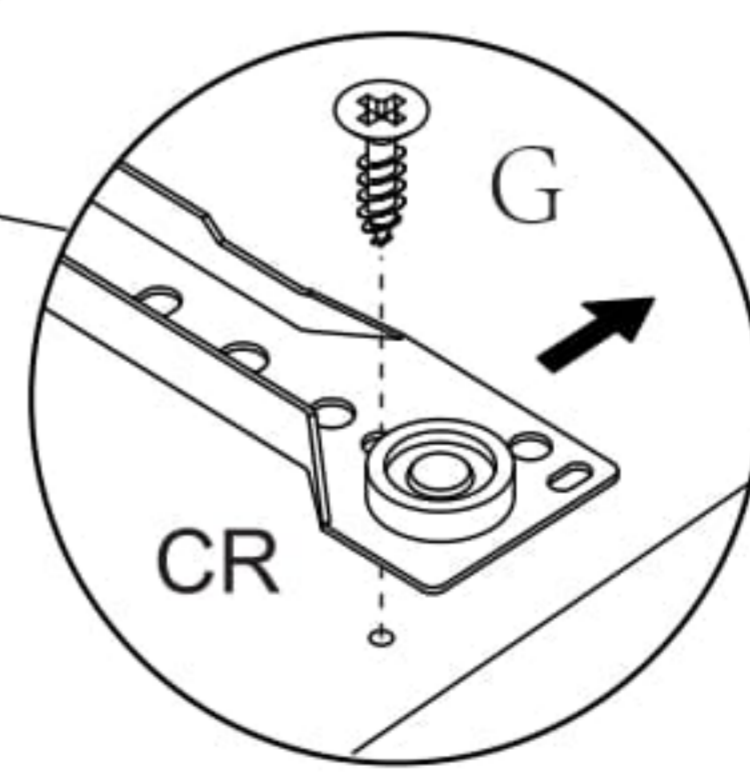
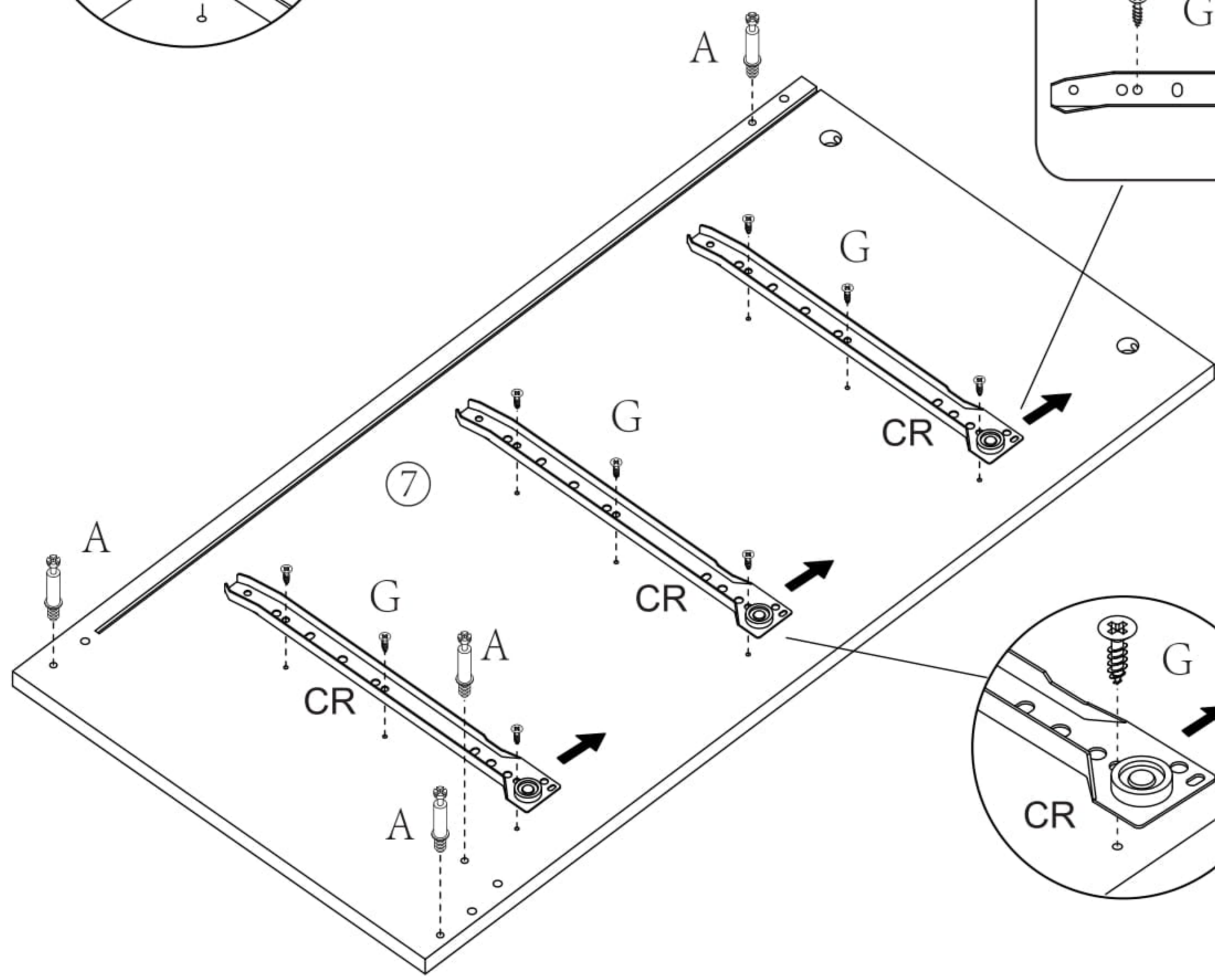
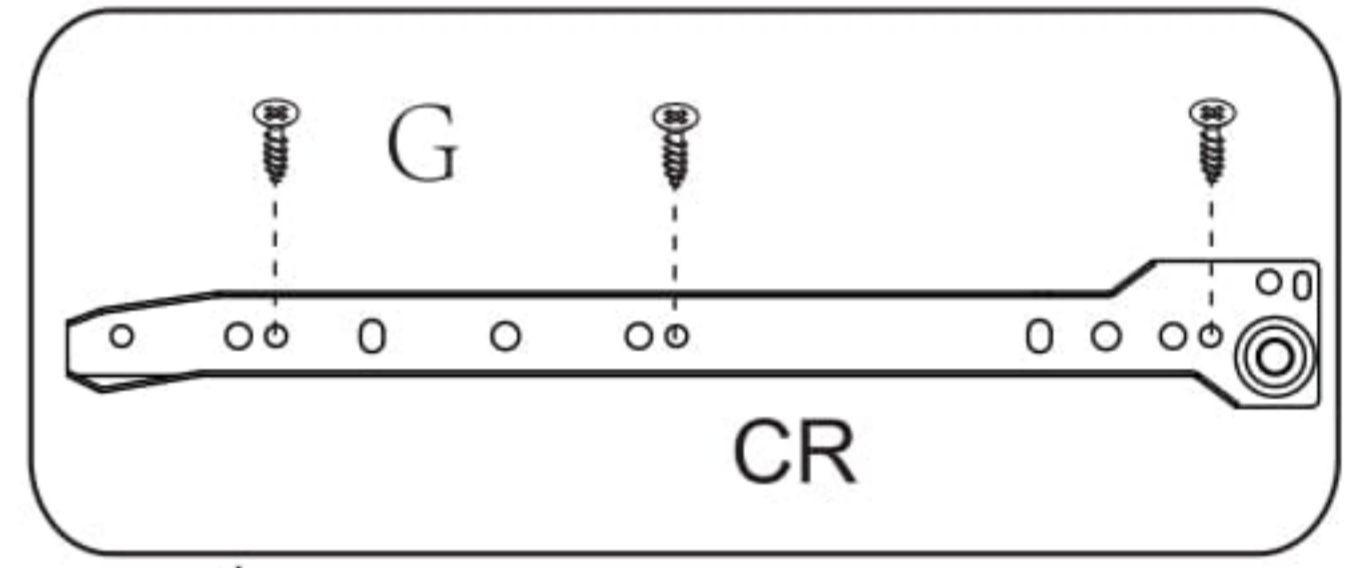
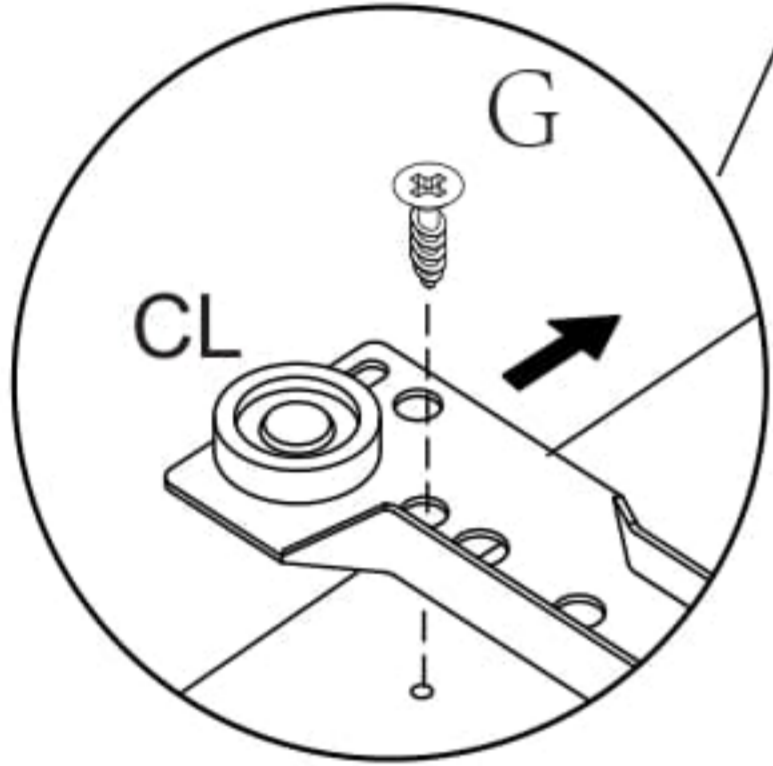
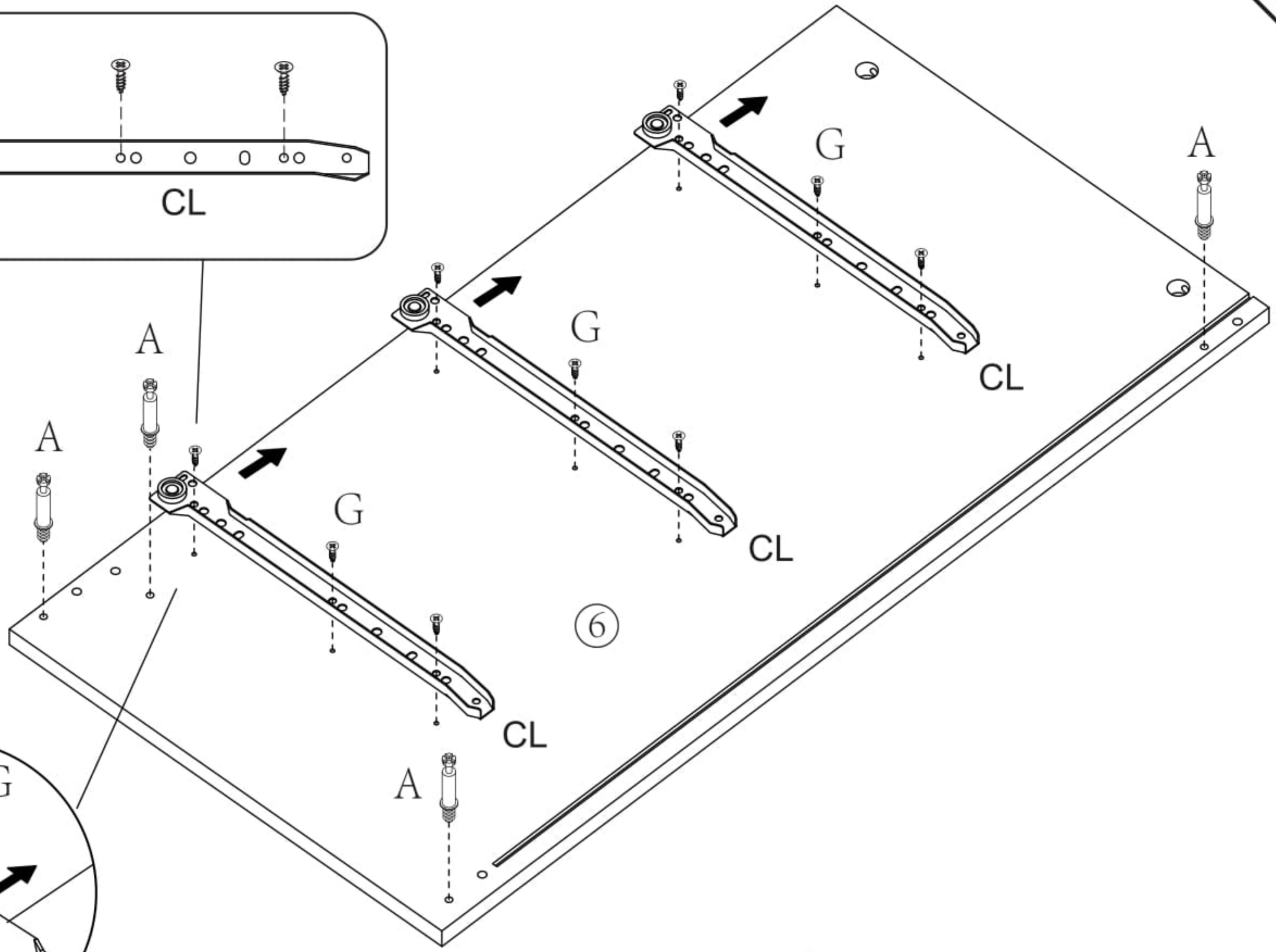
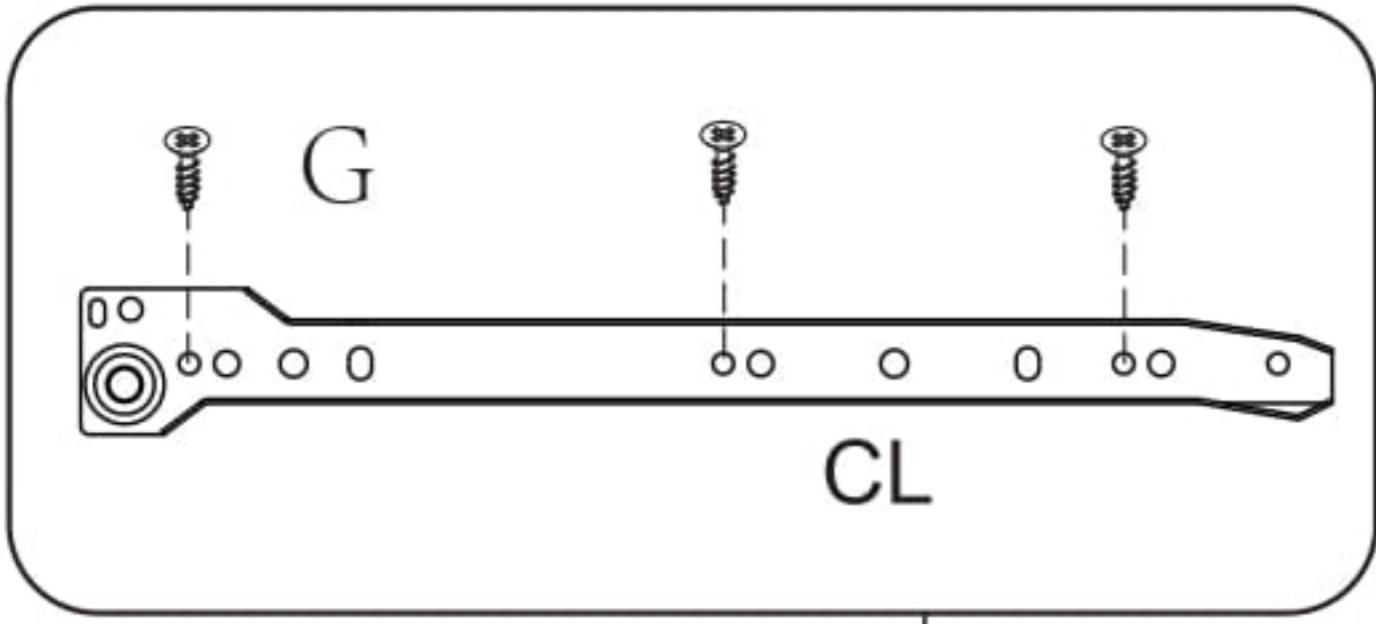

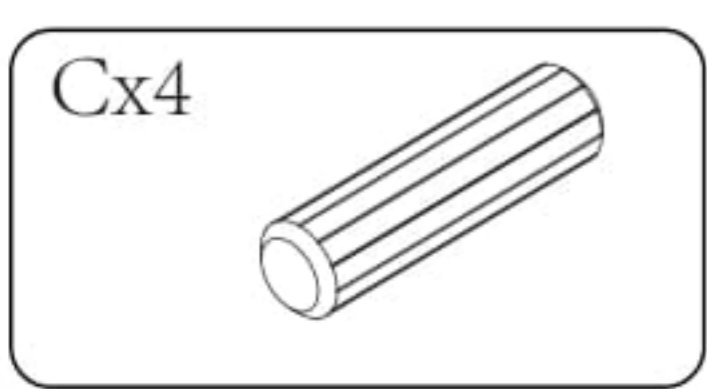
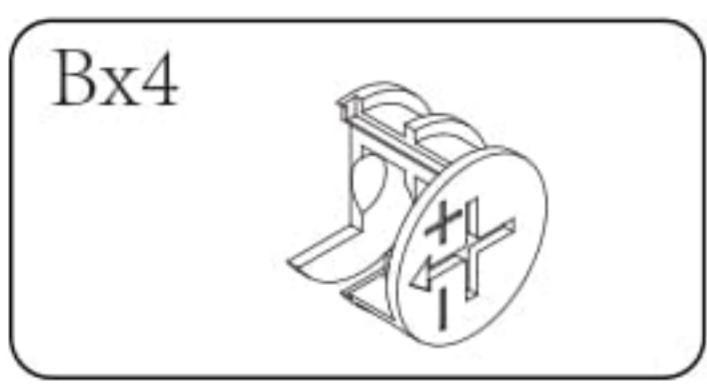
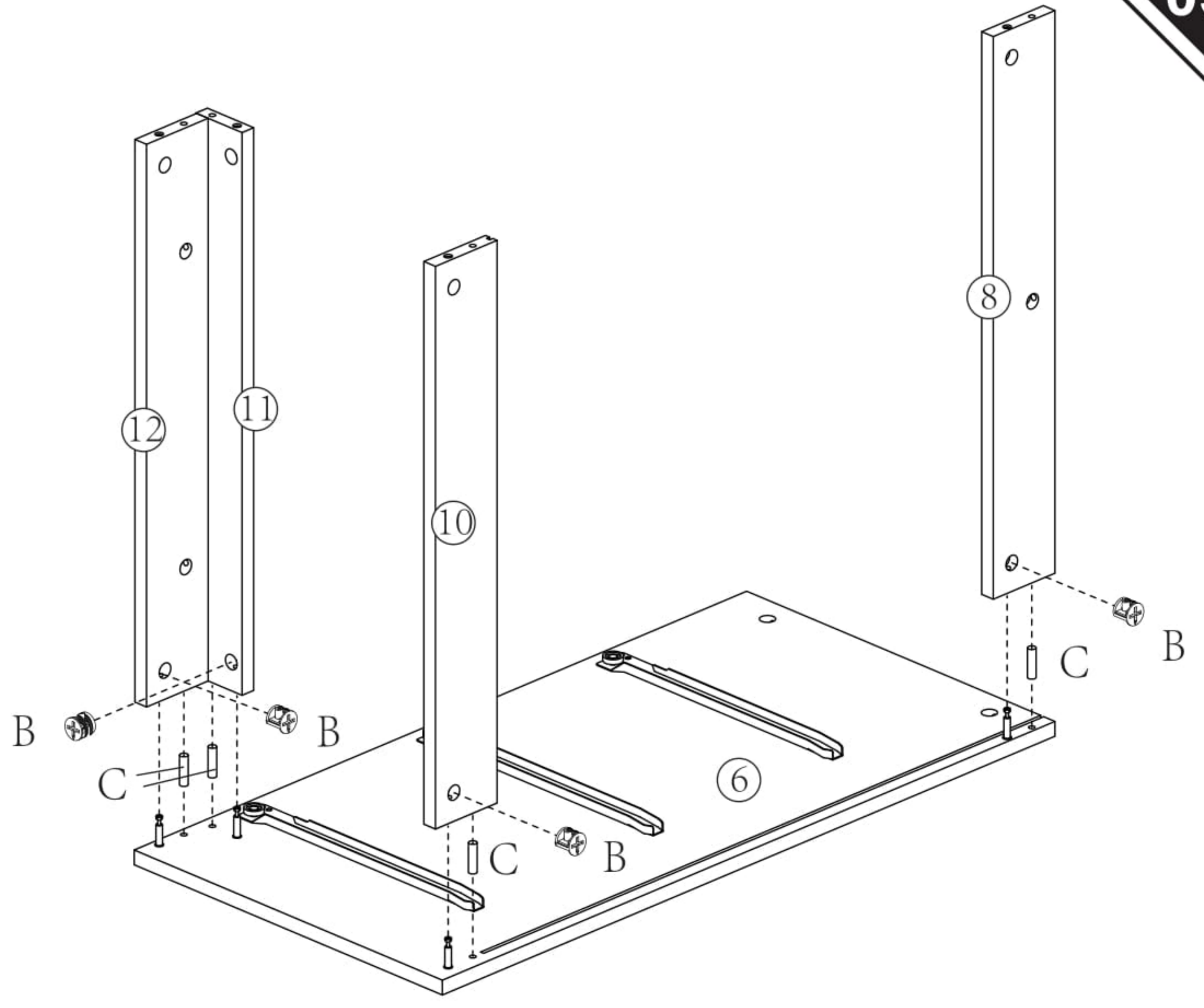
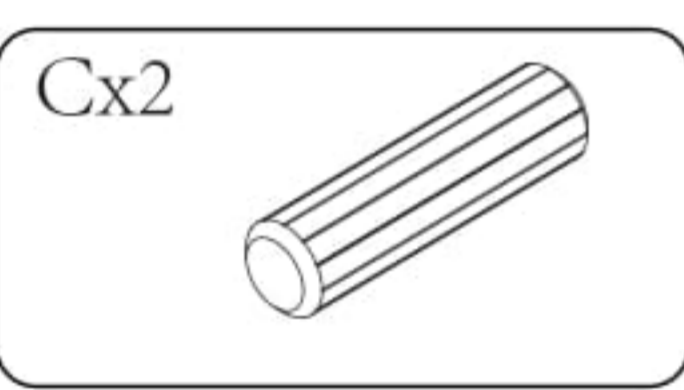
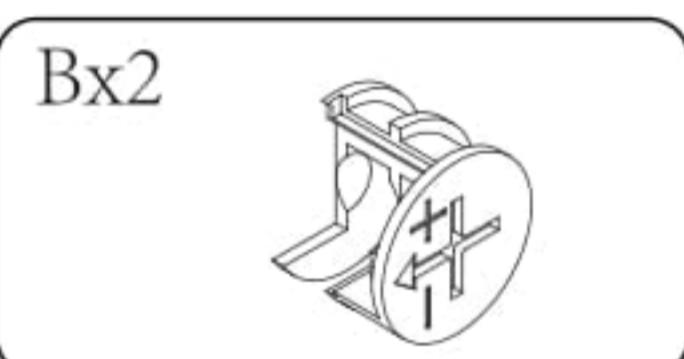
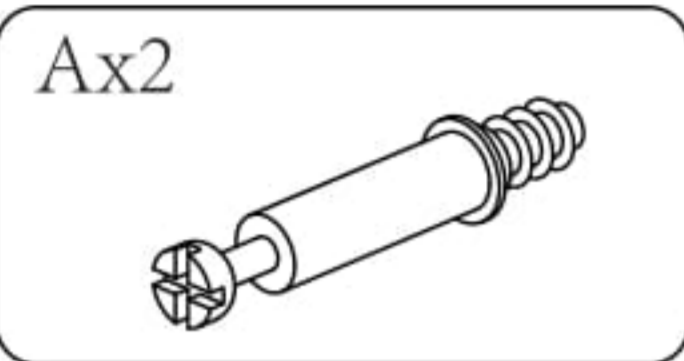
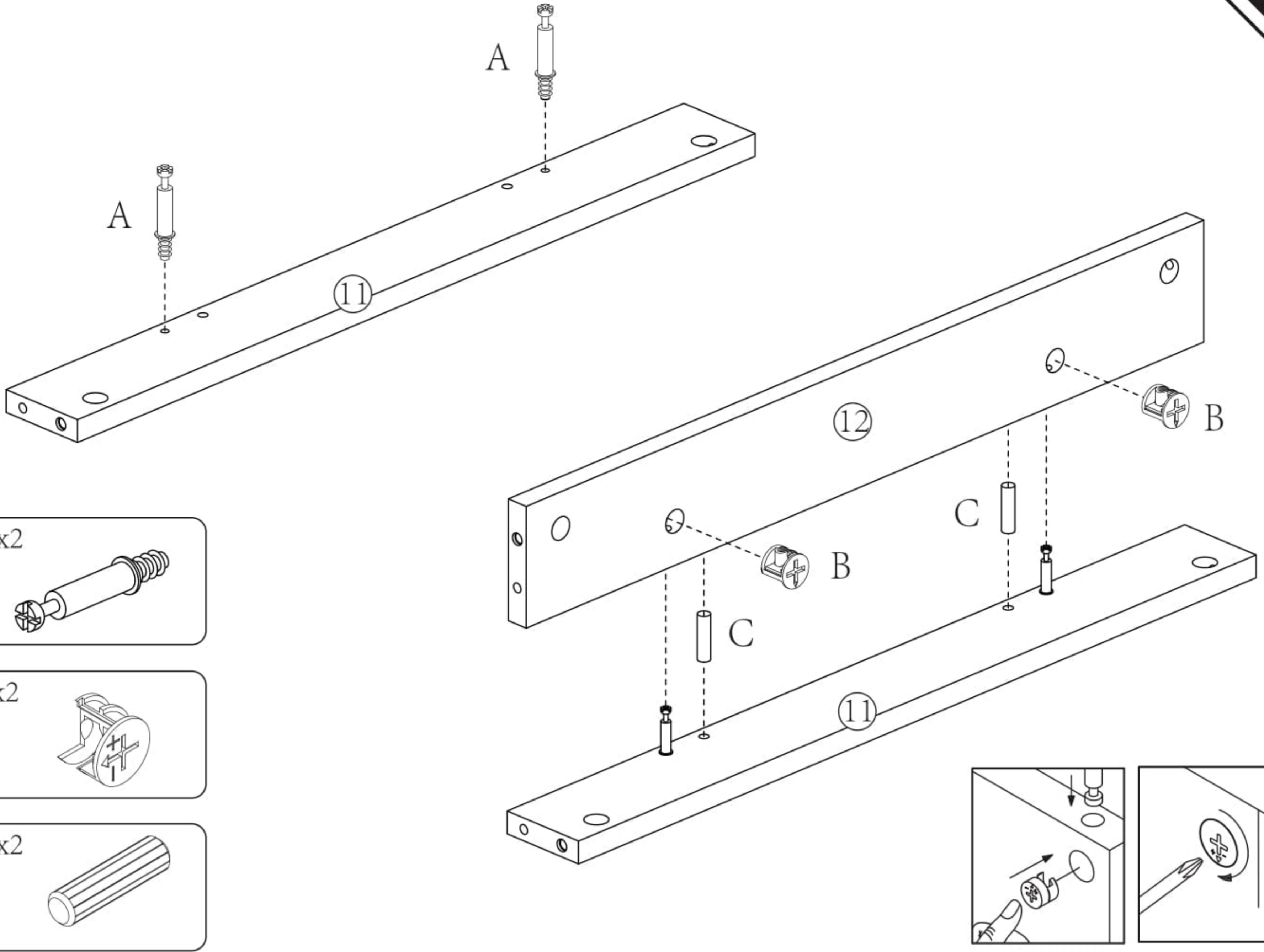

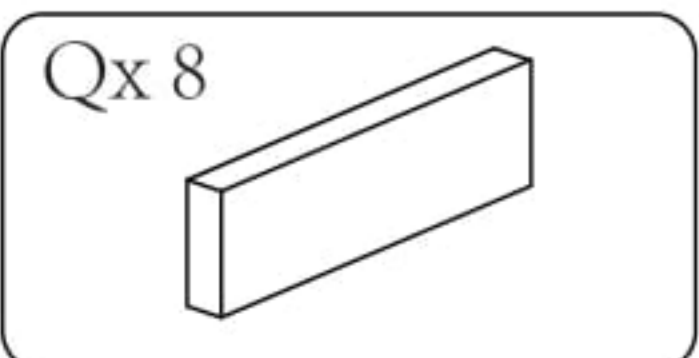
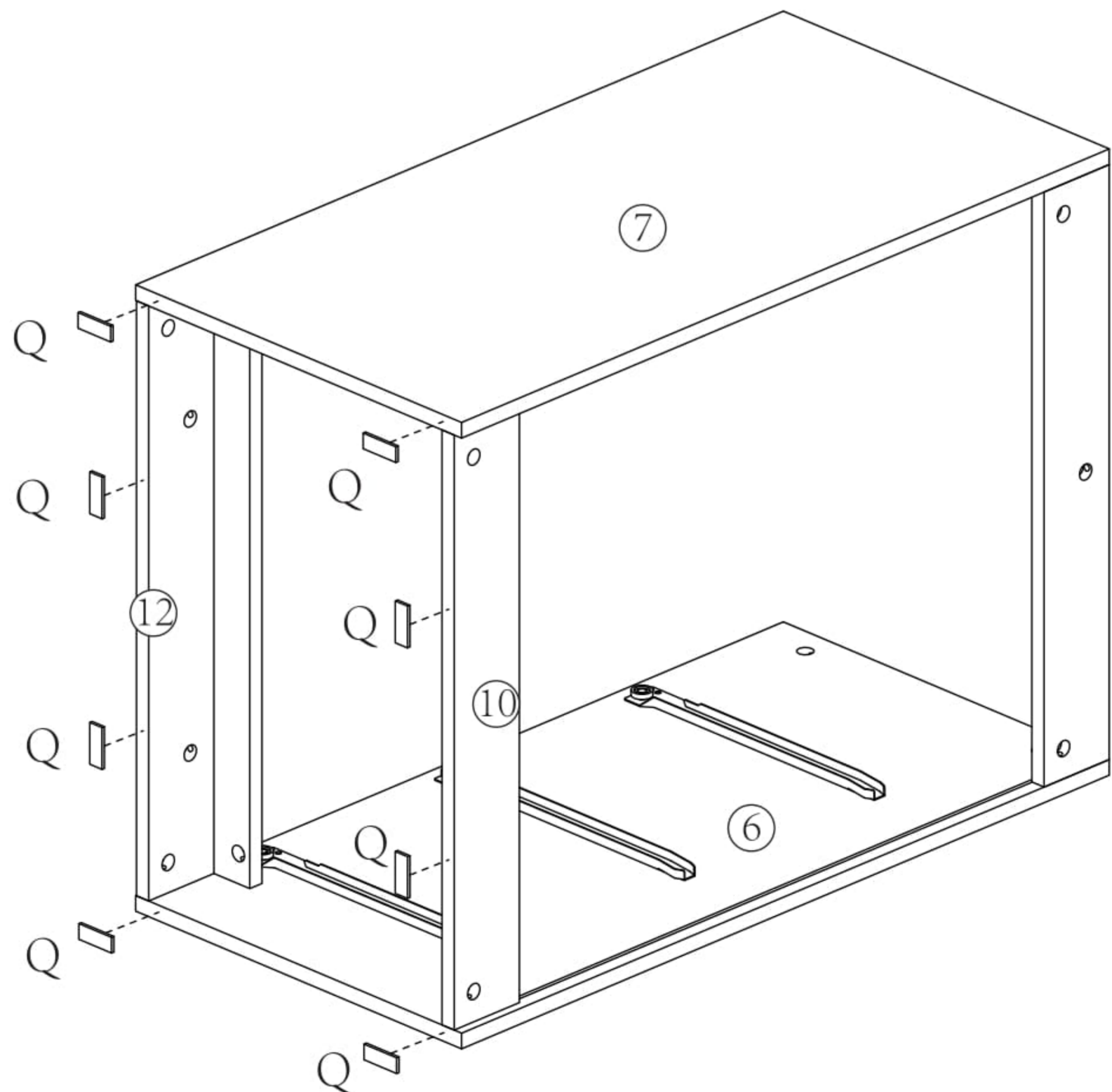
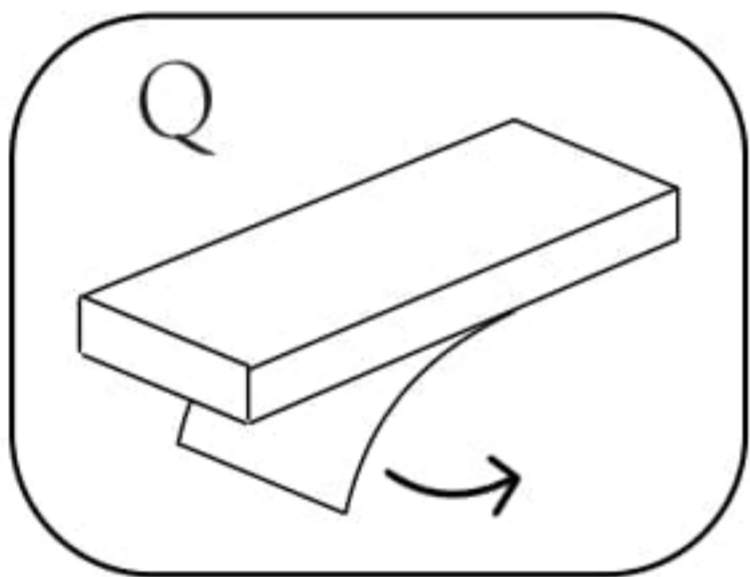
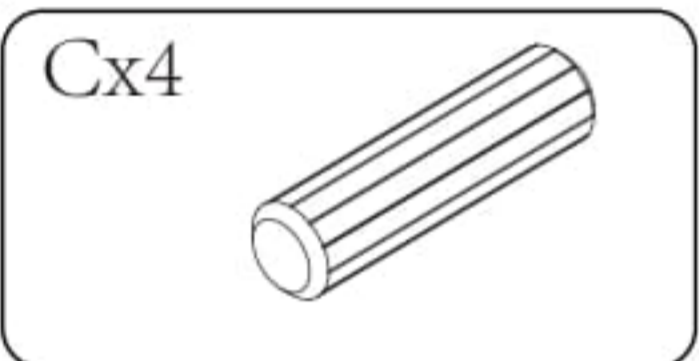
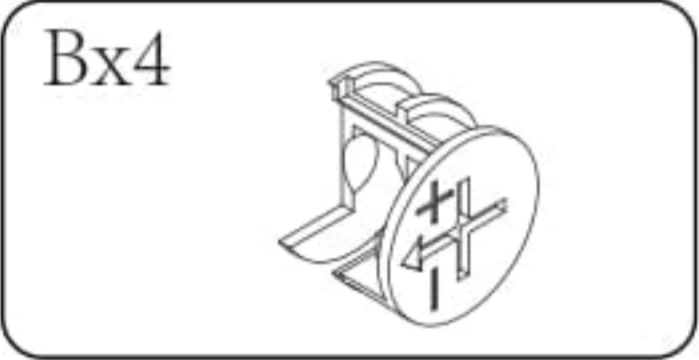
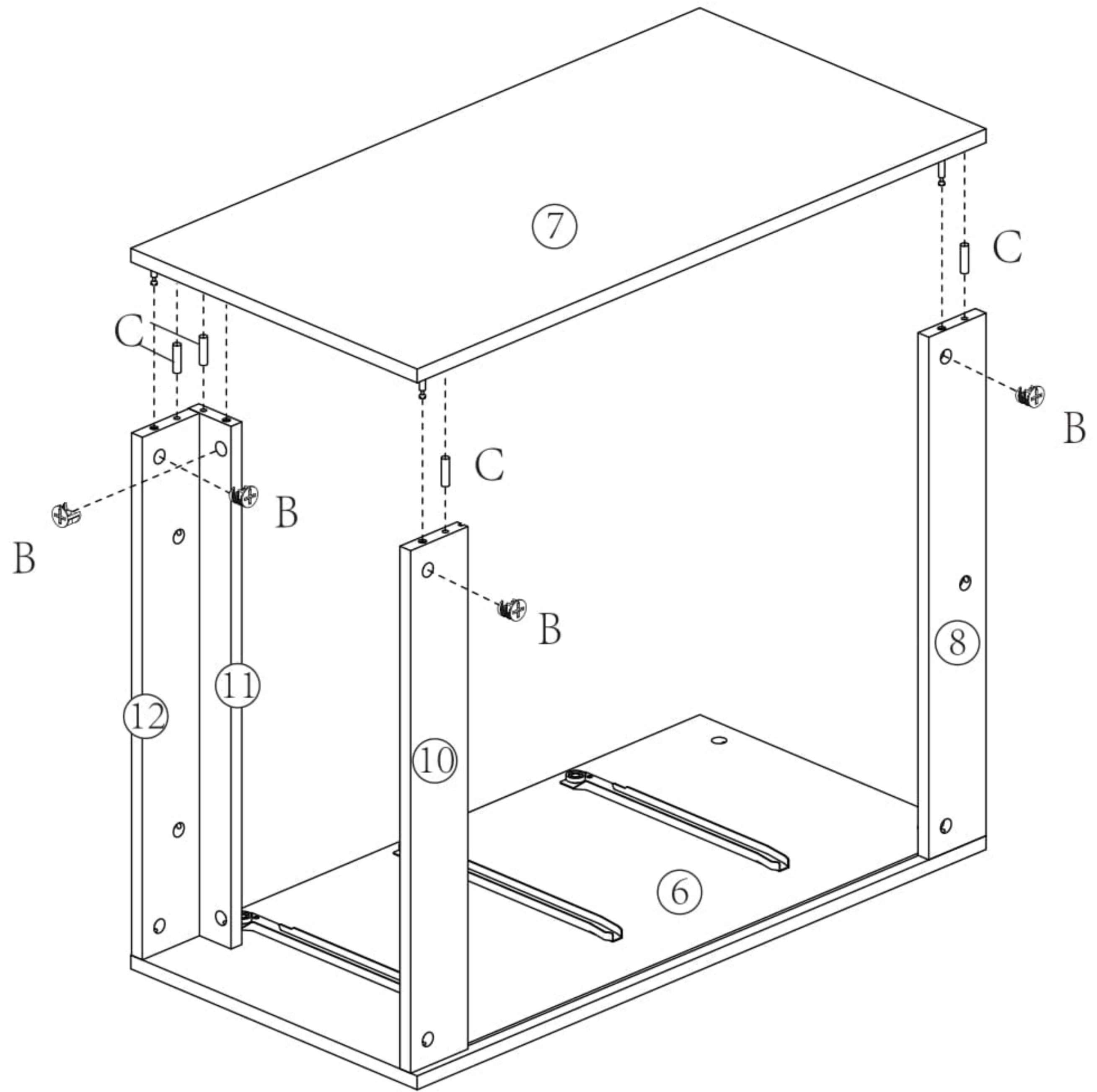

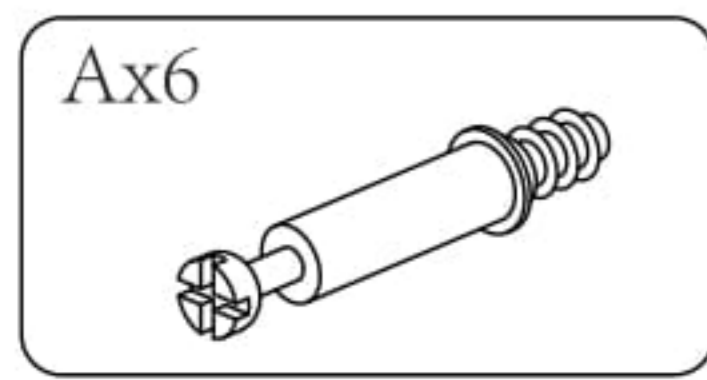
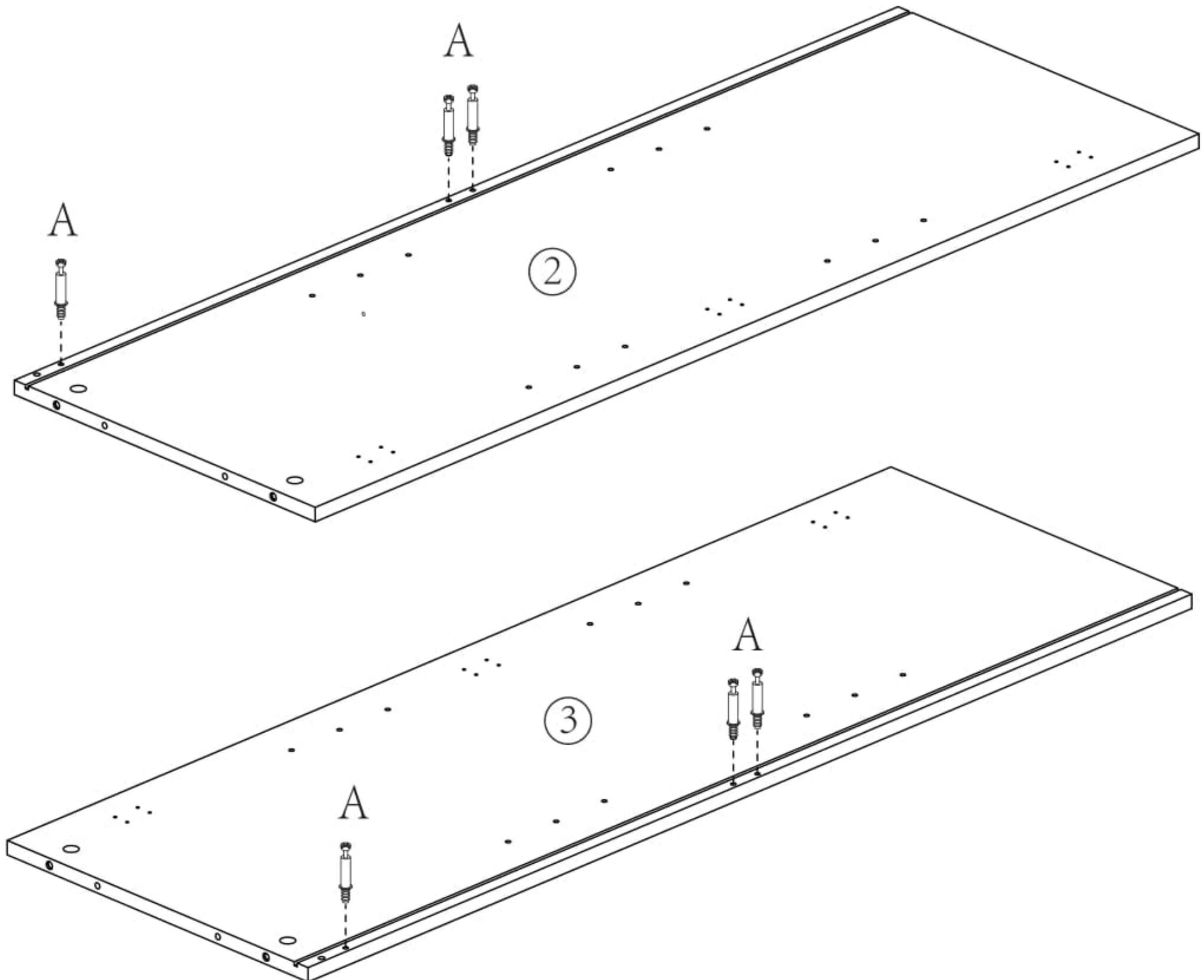
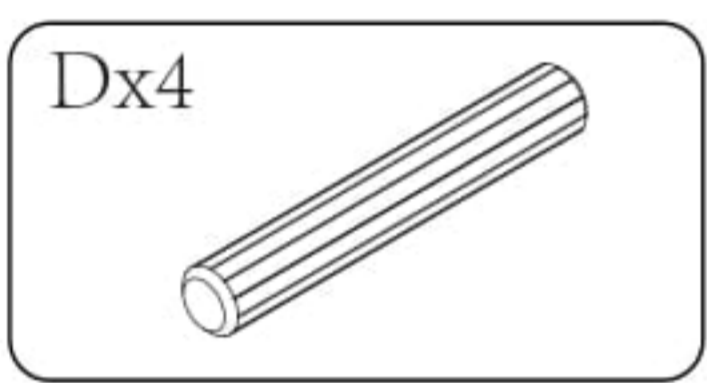
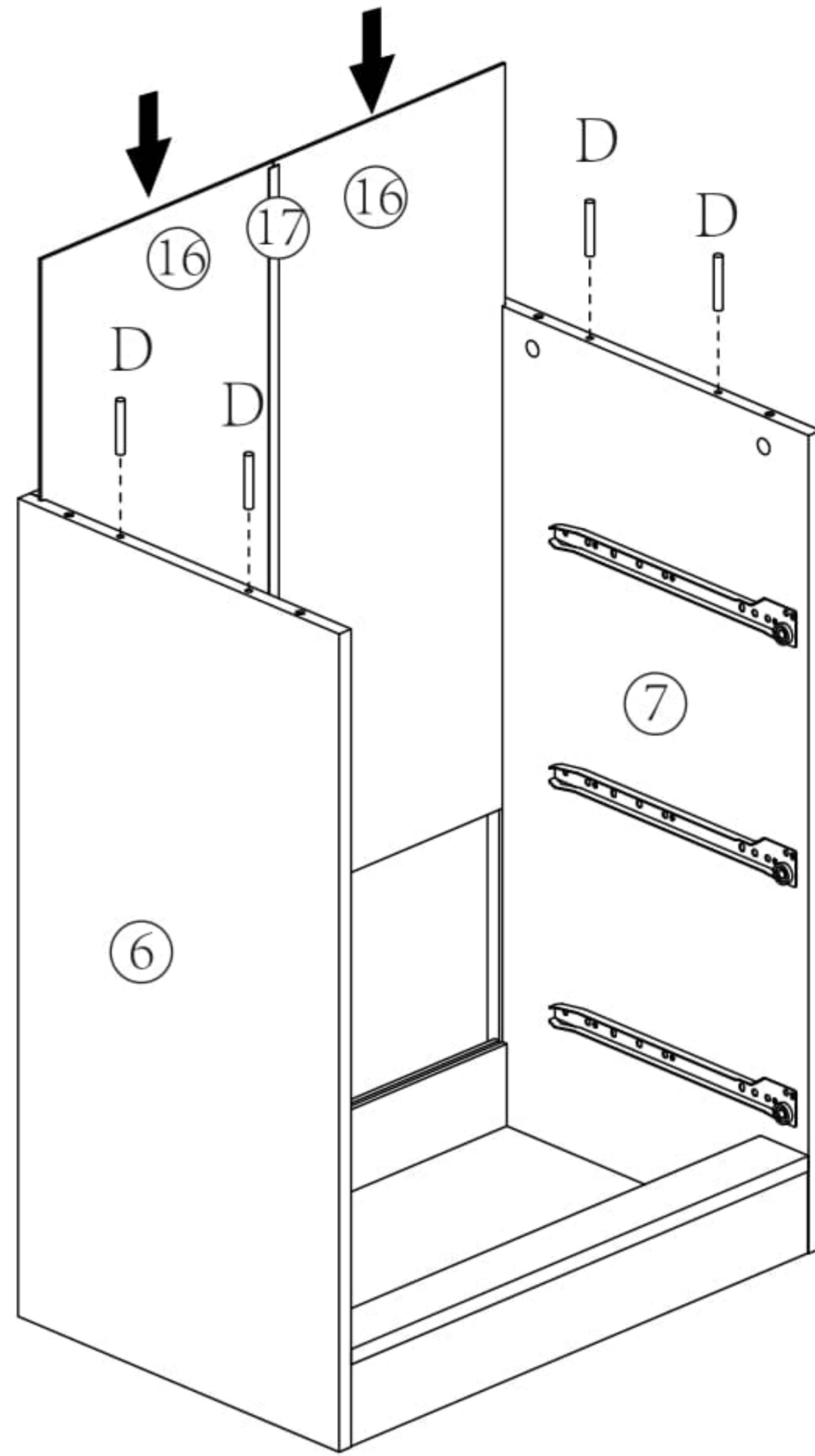
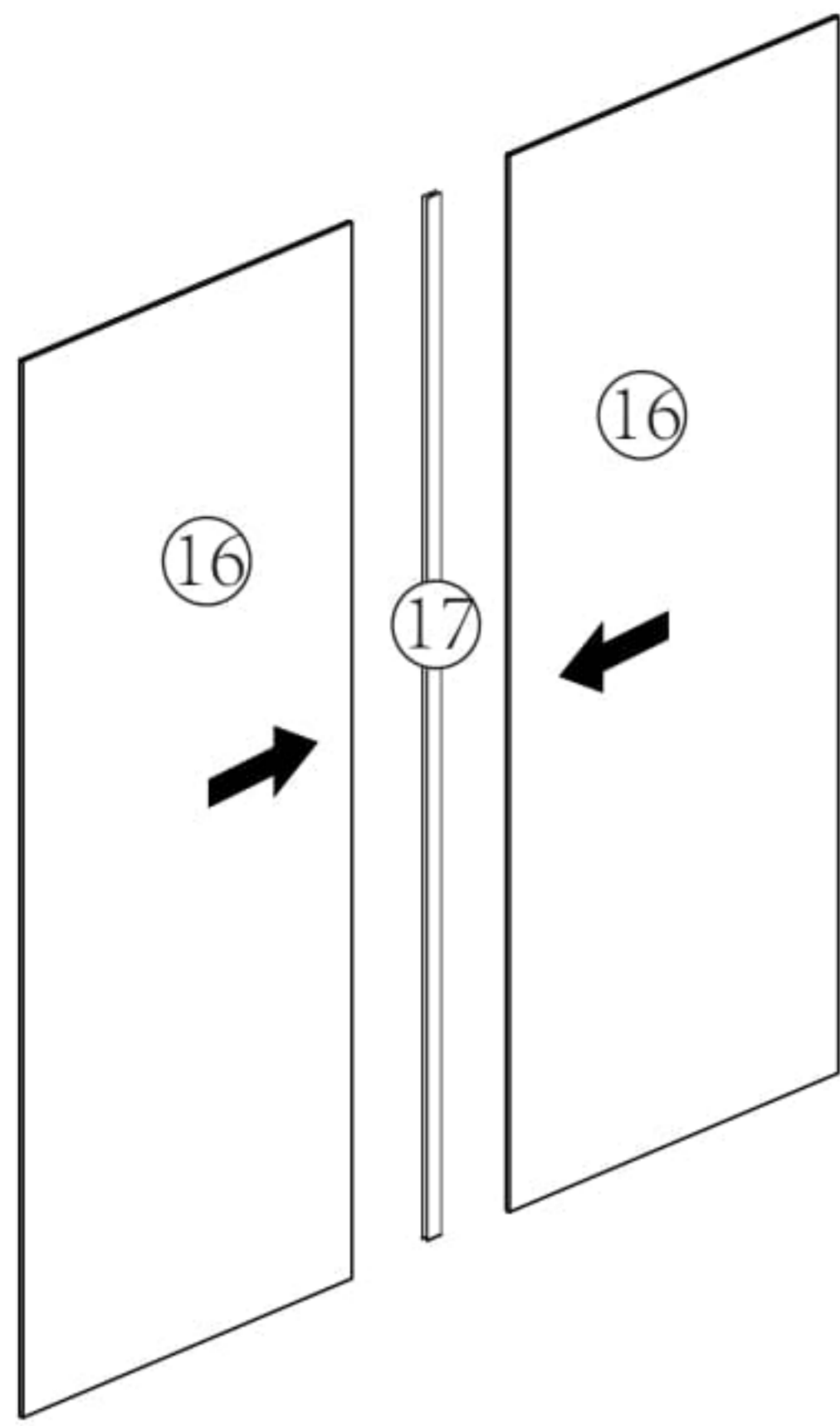

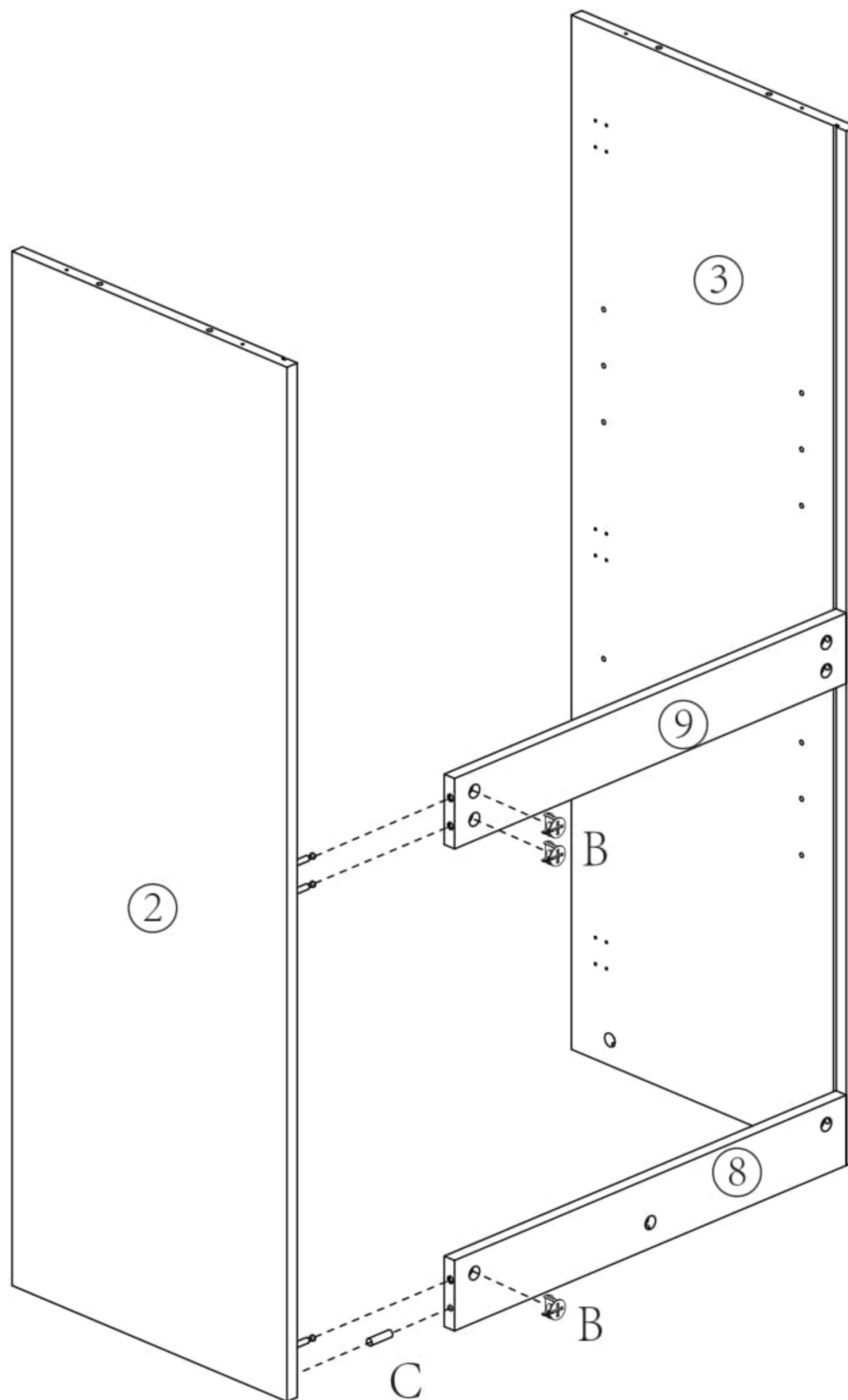
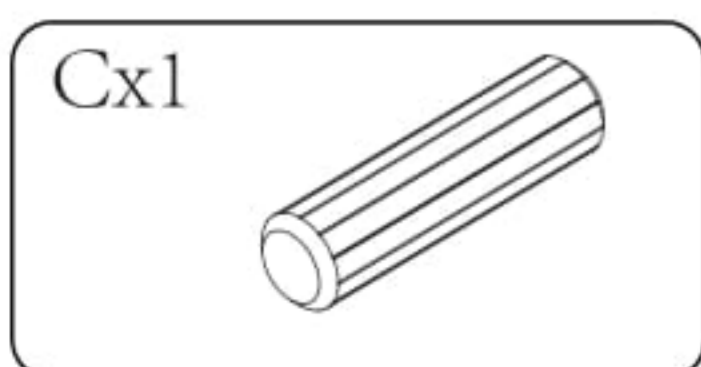
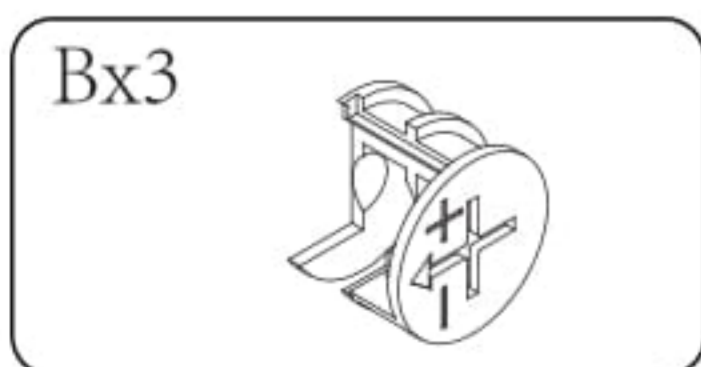
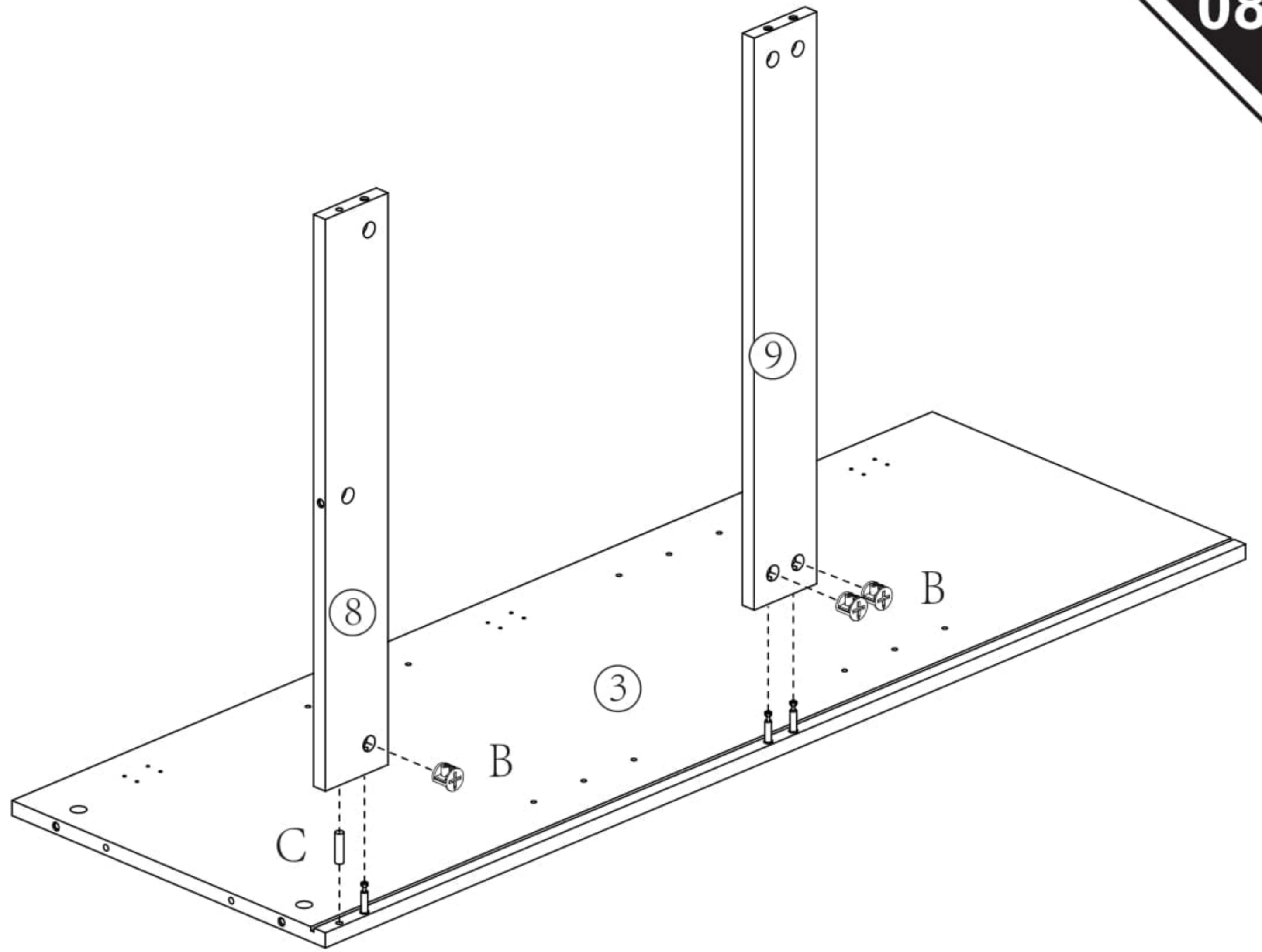
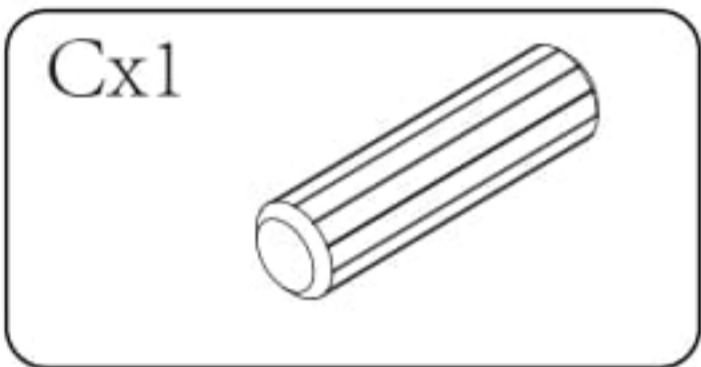
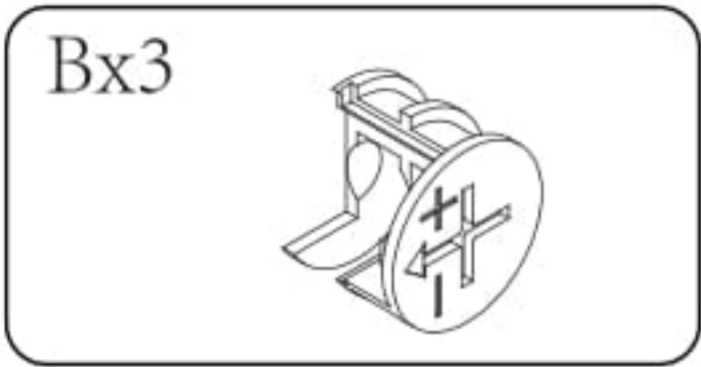

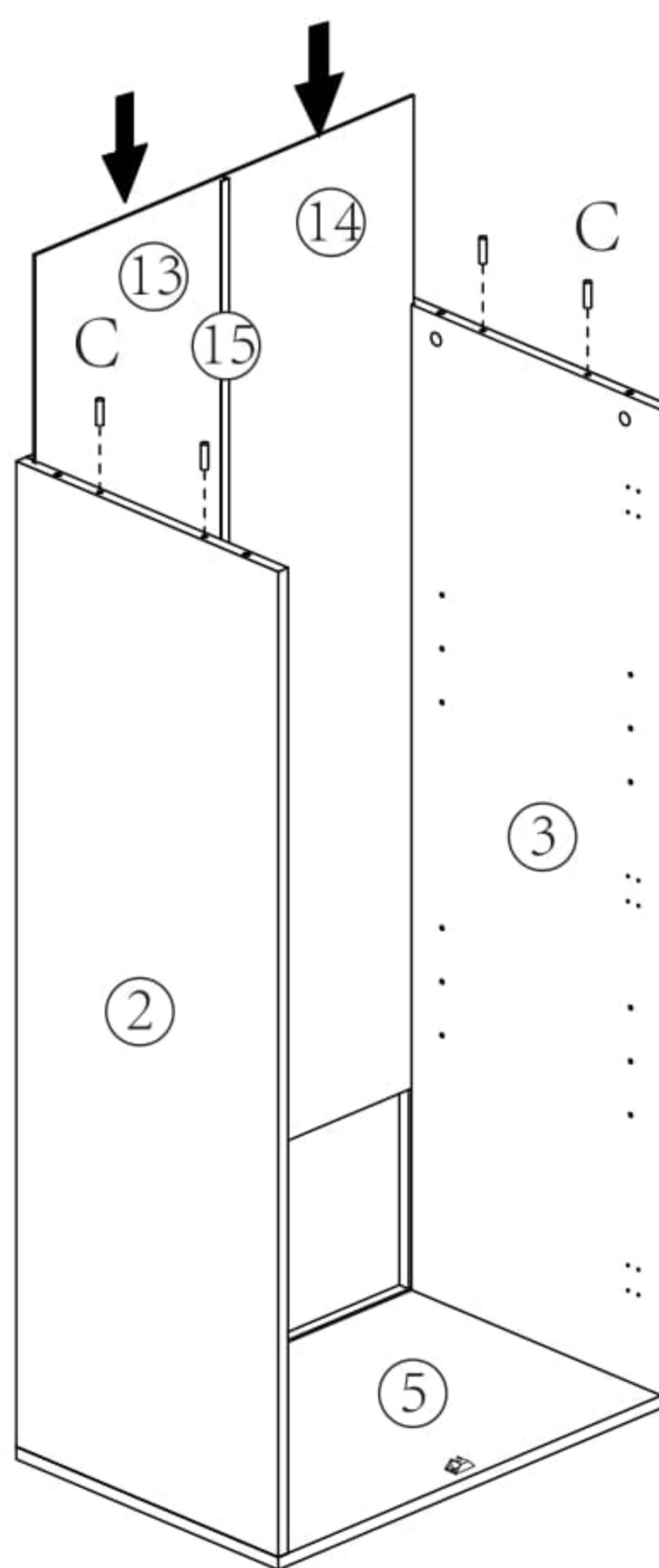
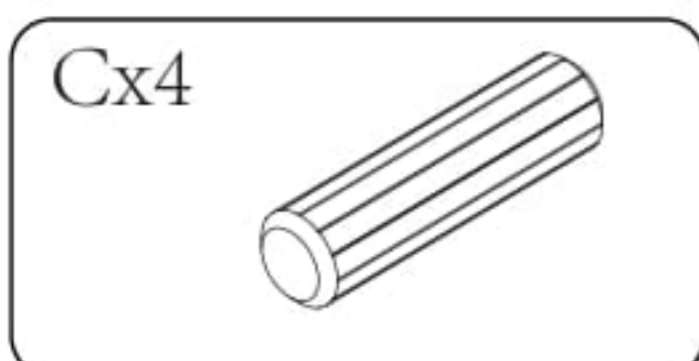
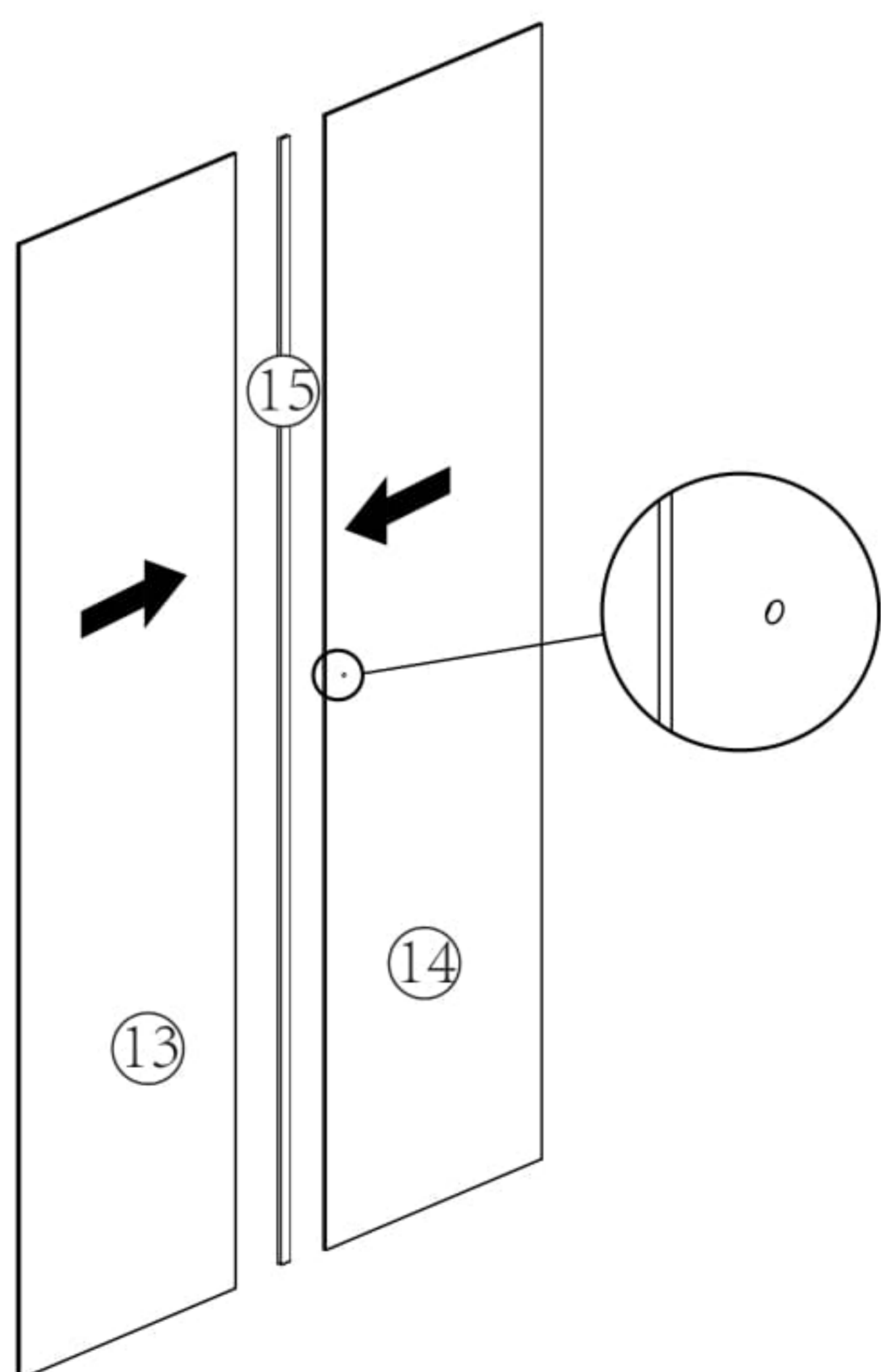
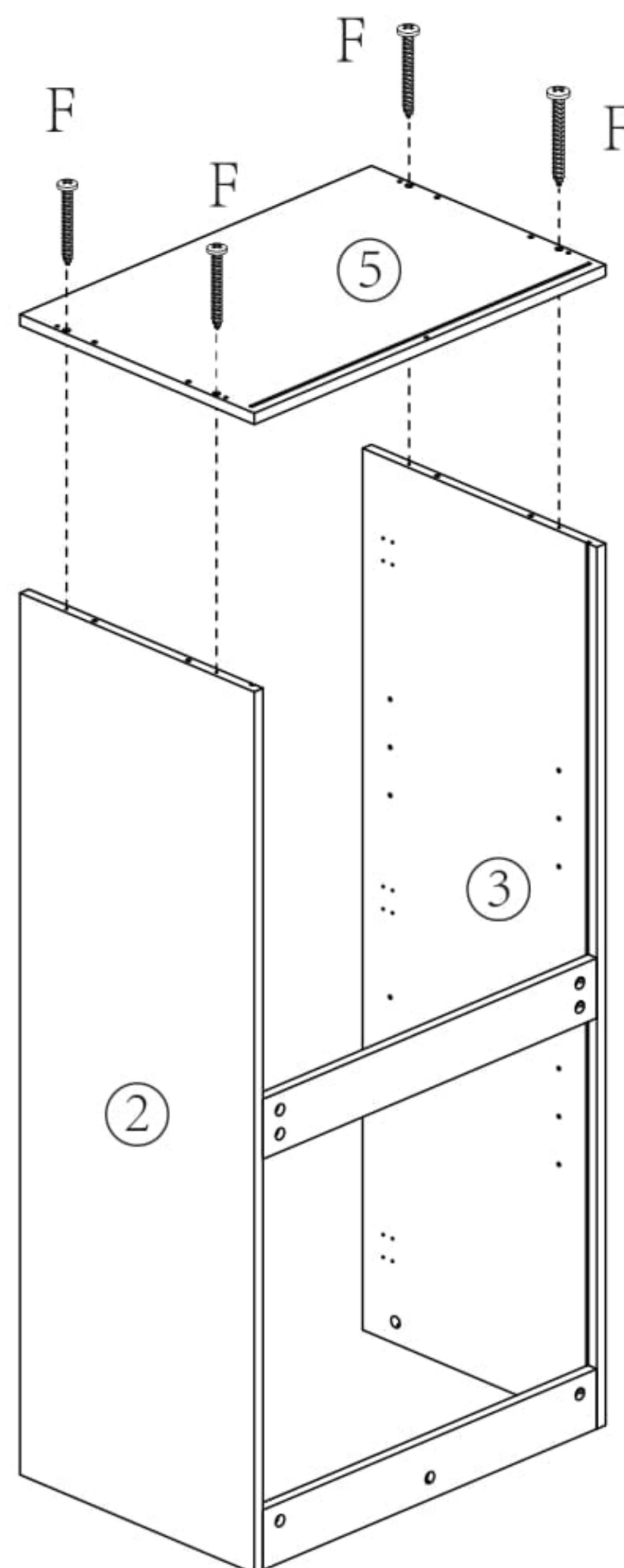
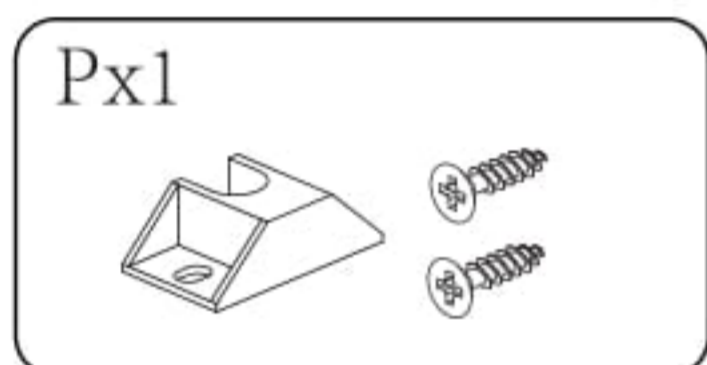
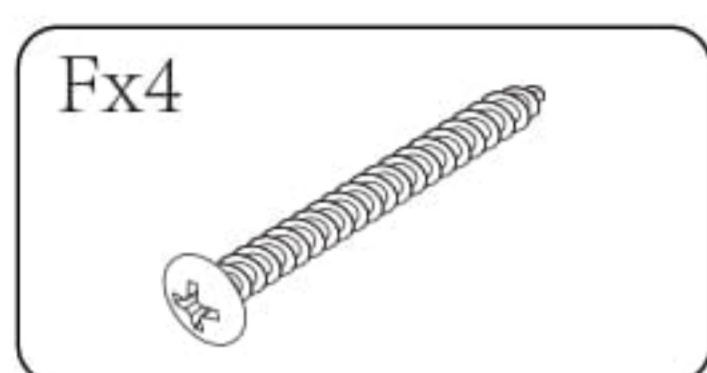
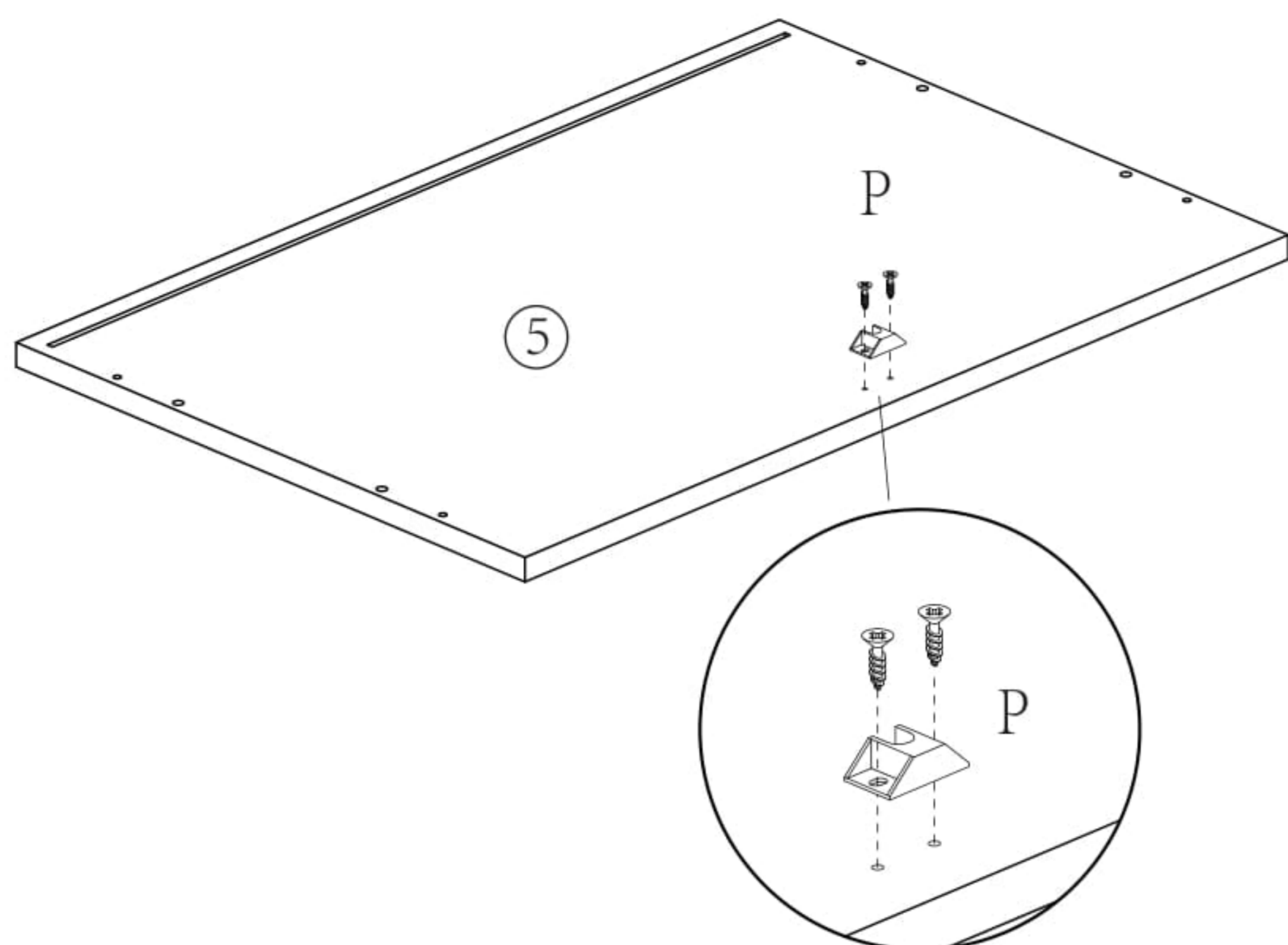

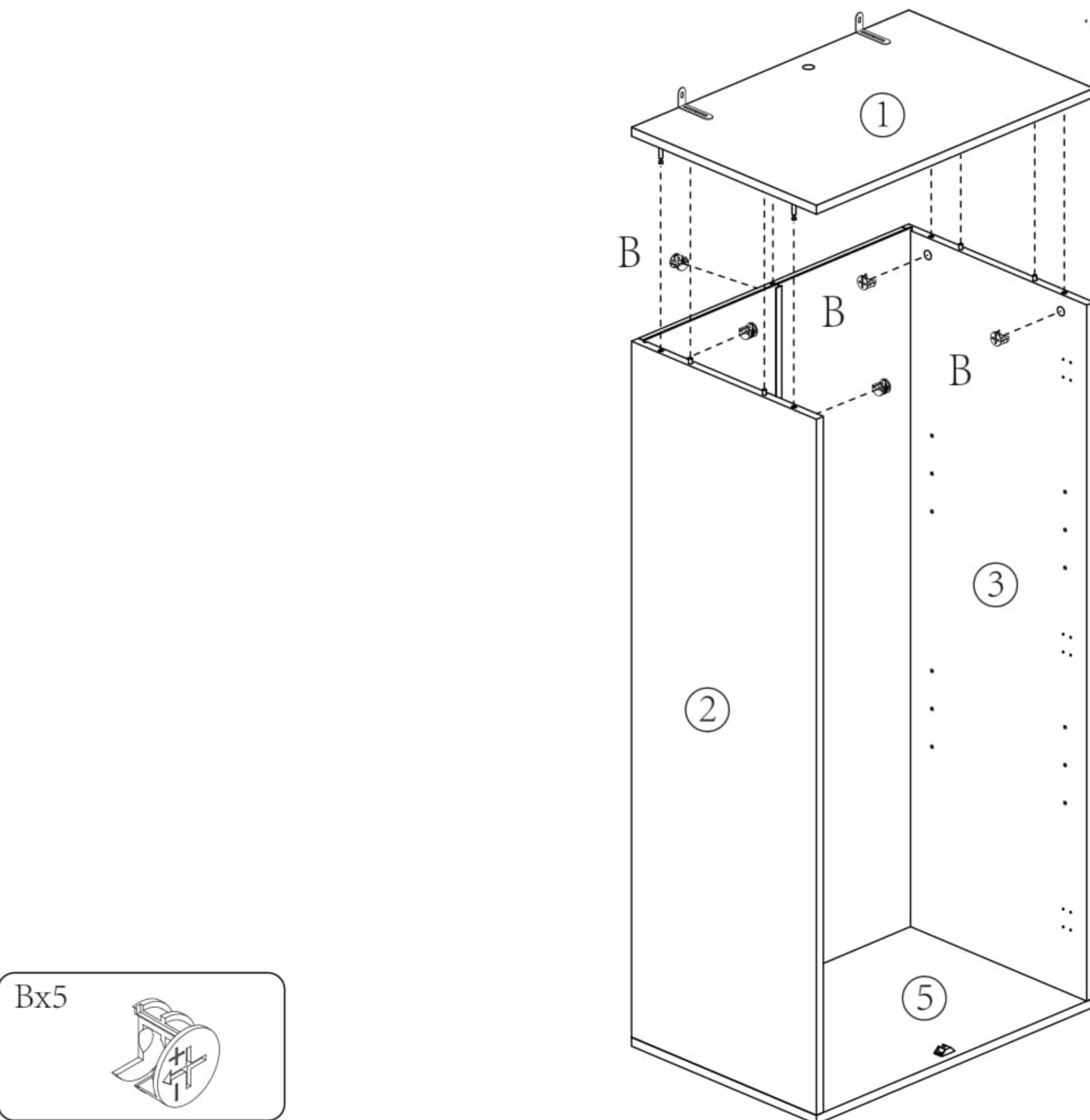
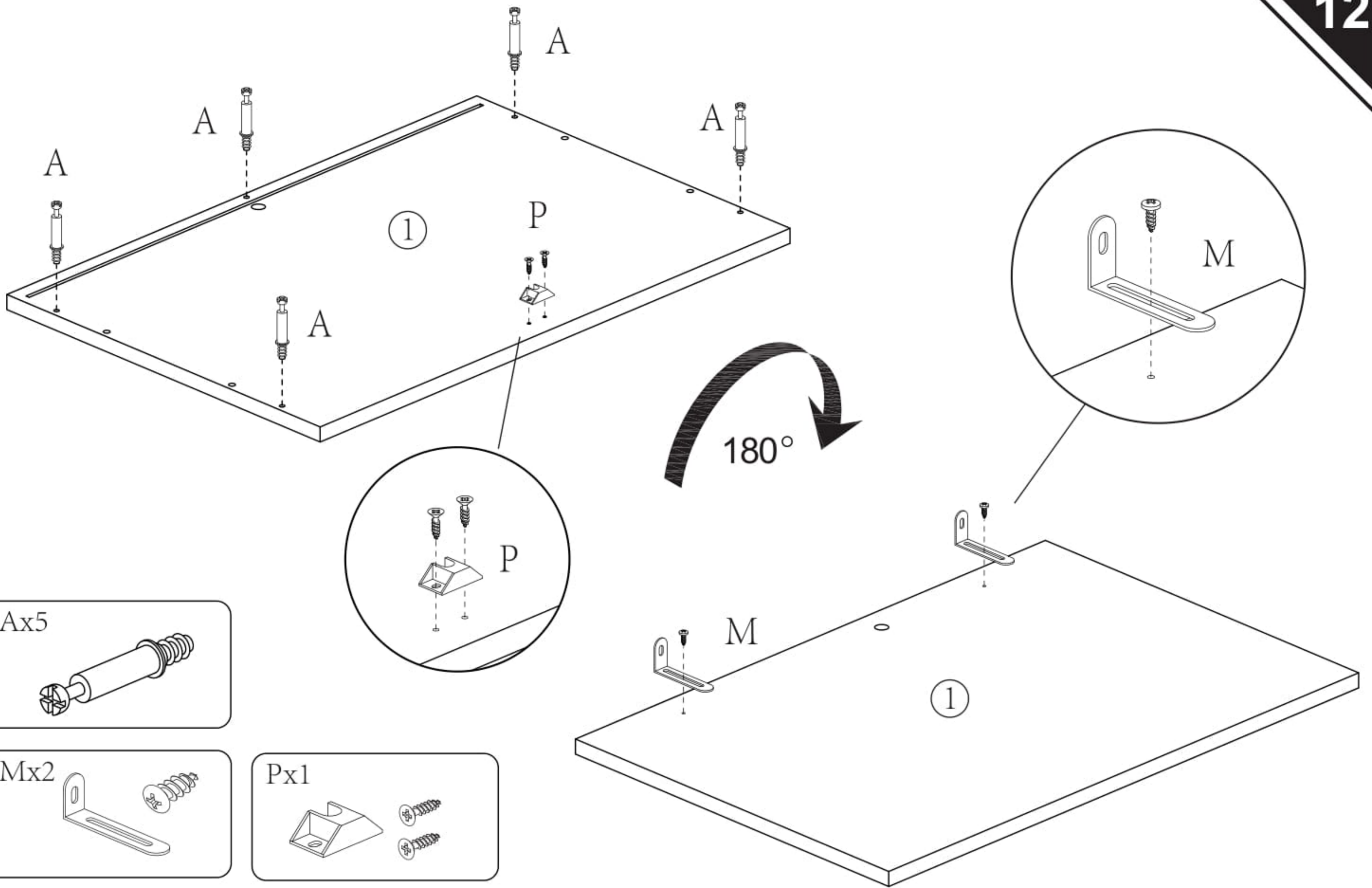

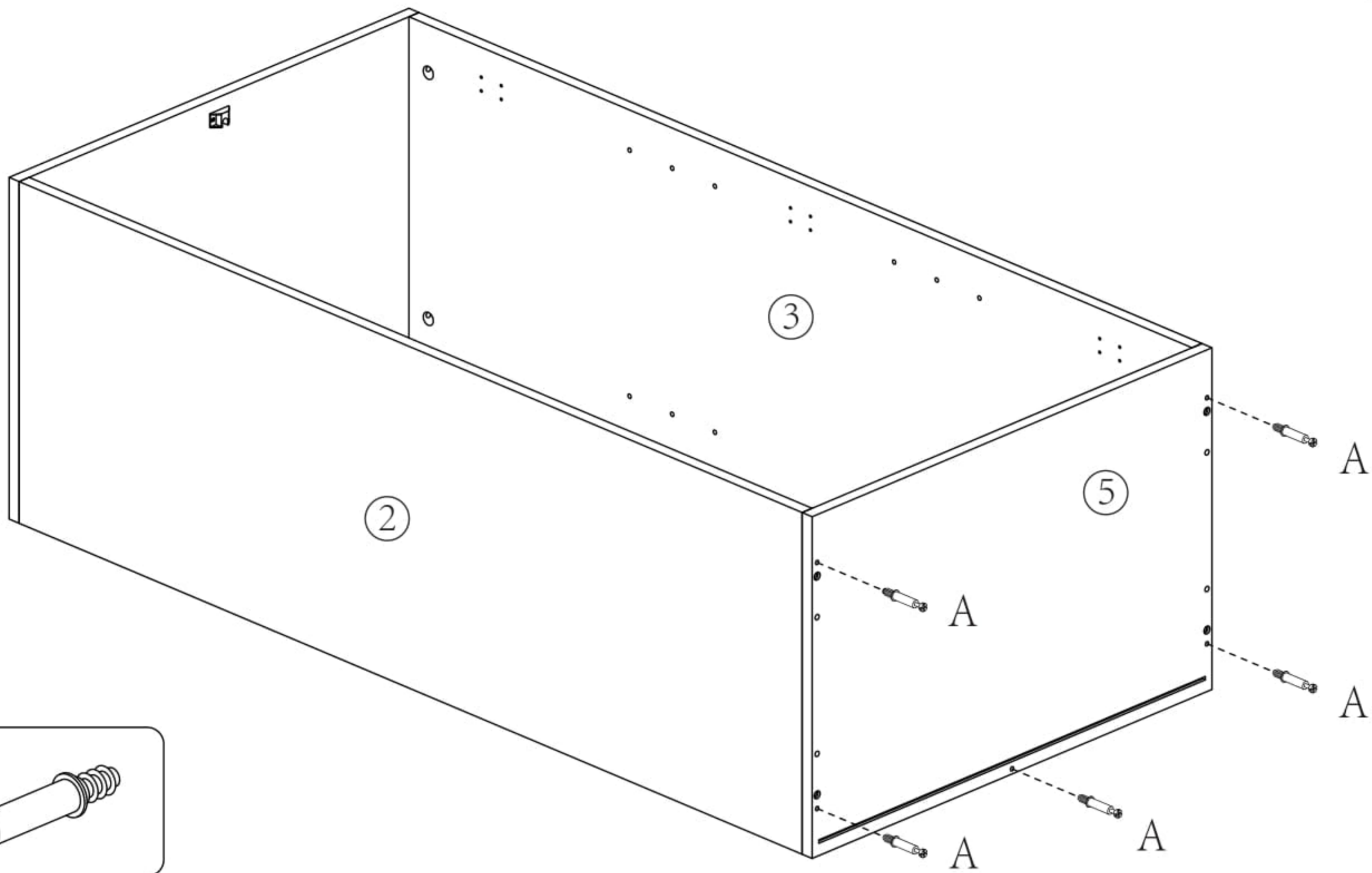

Ax5

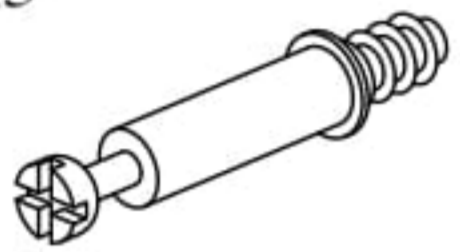

DE

Bitte stellen Sie die beiden Schrankteile aufrecht auf, um sie zusammenzubauen, und vermeiden Sie, dass die Rückwand nicht ausgerichtet werden kann.

EN

Please stand the two cabinet parts upright for assembly to avoid misalignment of the back panel.

FR

Veillez placer les deux parties du meuble en position verticale pour l'assemblage afin d'éviter que le panneau arrière ne puisse pas être aligné.

ES

Por favor, coloque las dos partes del armario en posición vertical para el ensamblaje, evitando que el panel trasero no pueda alinearse.

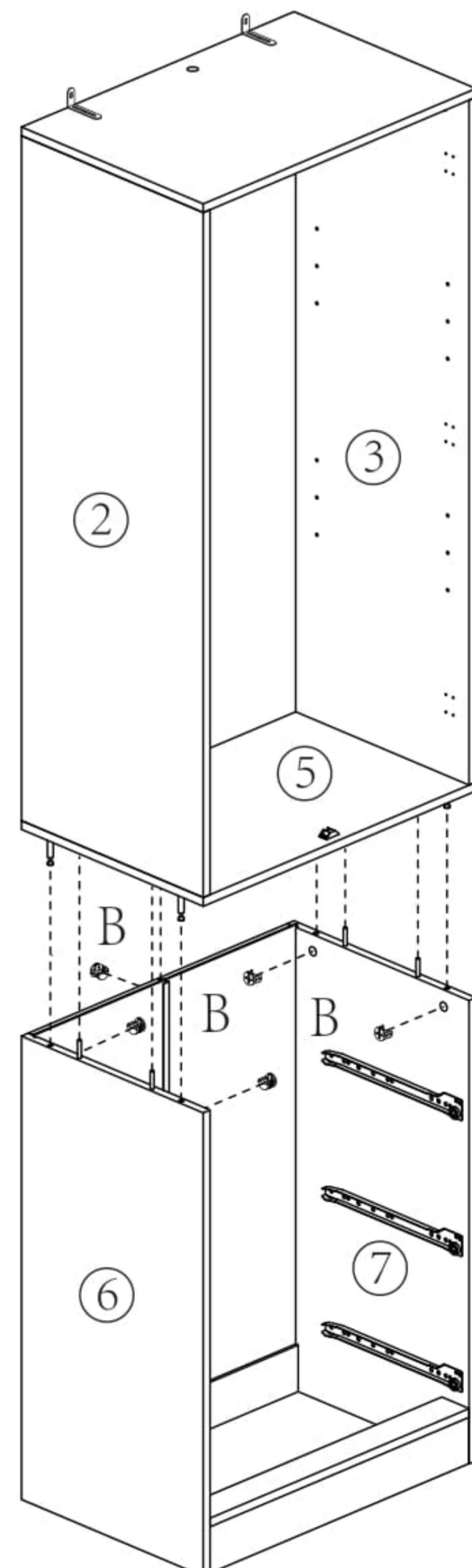

Bx5



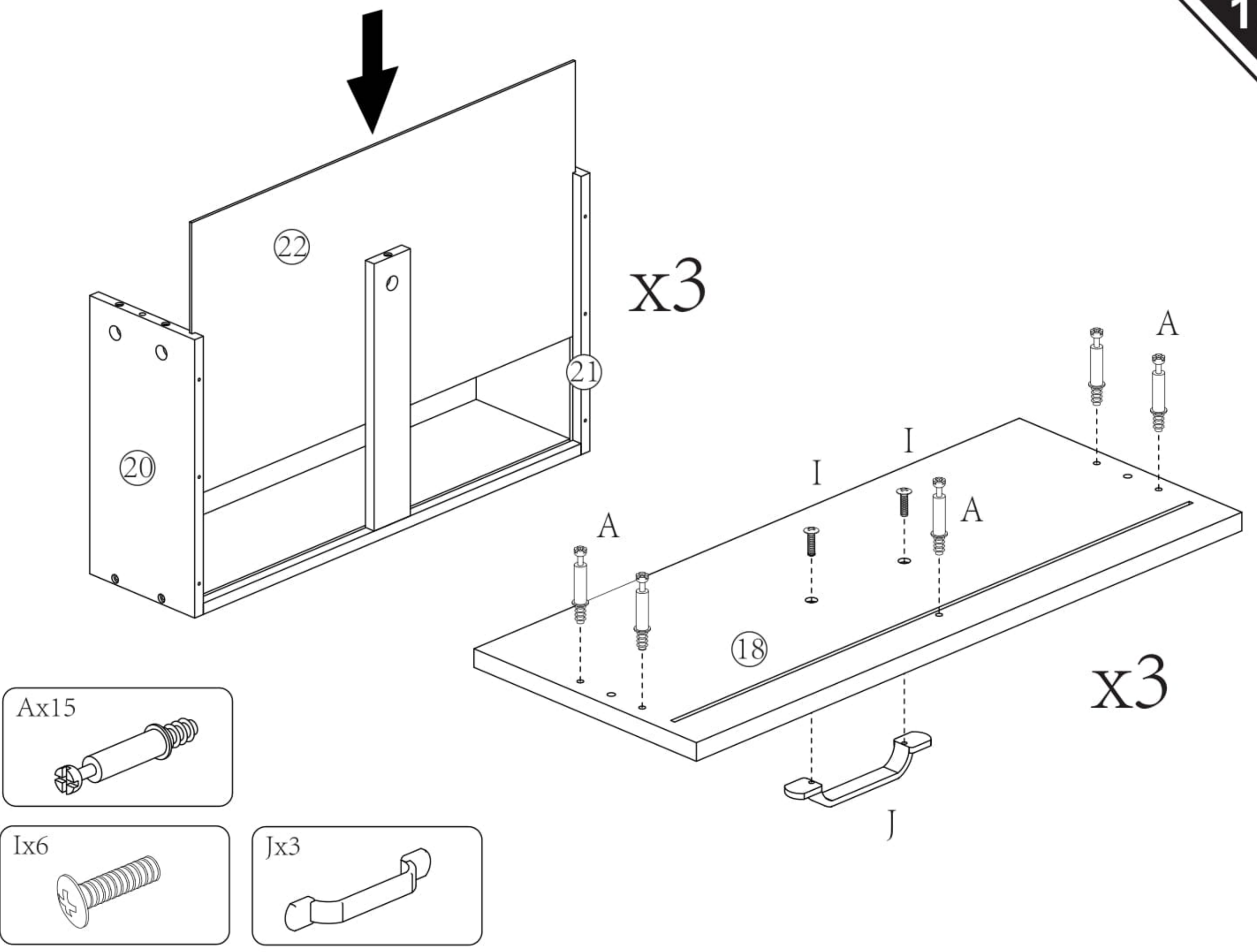
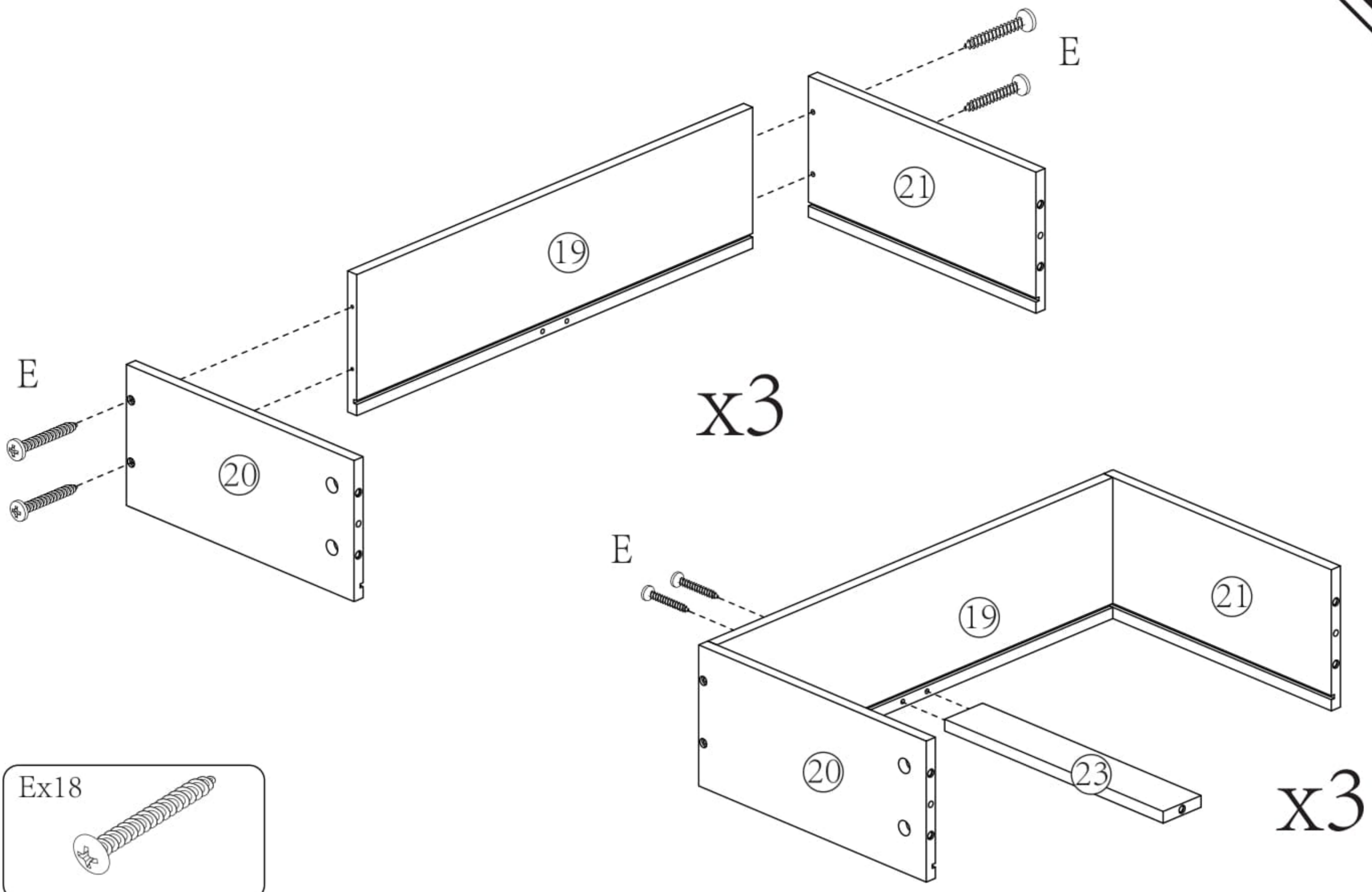

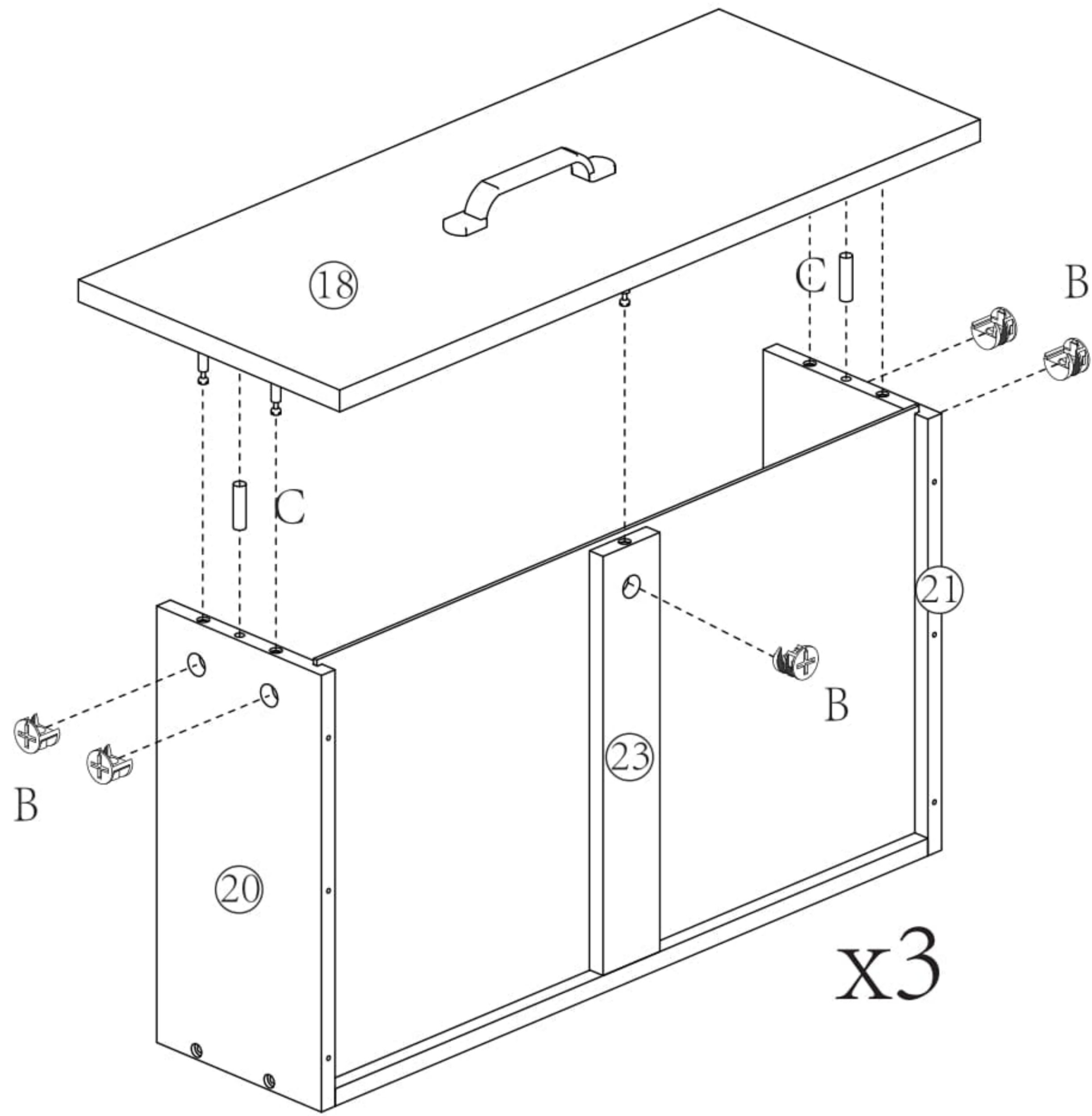

Bx15



Cx6

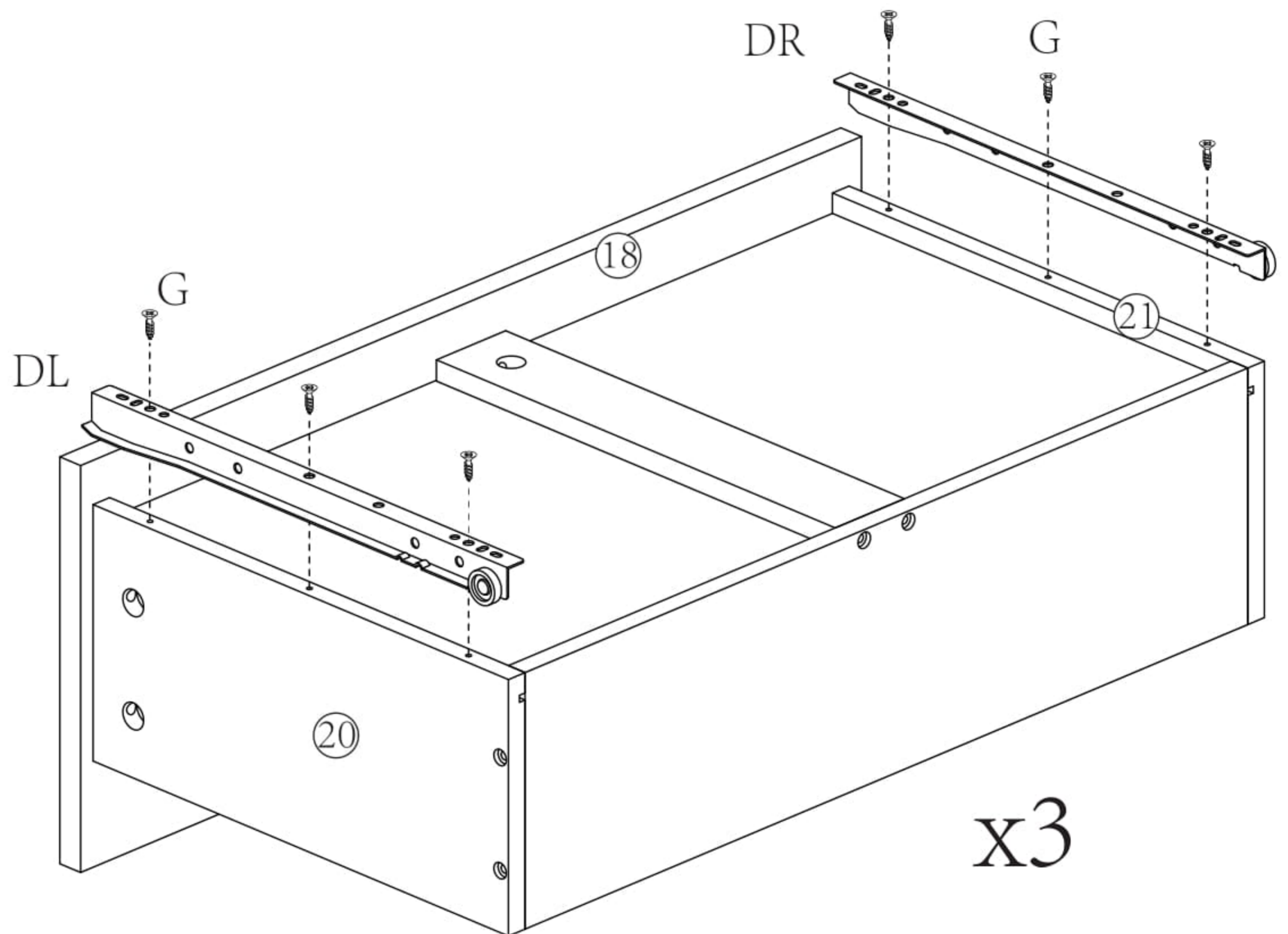
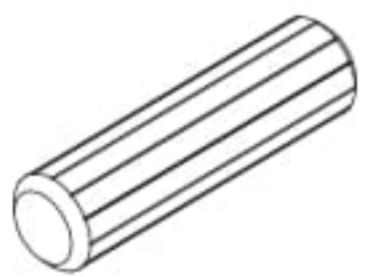

Gx18

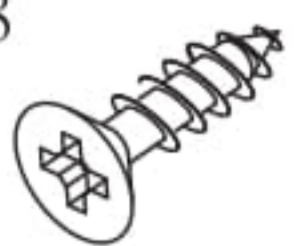

DLx3

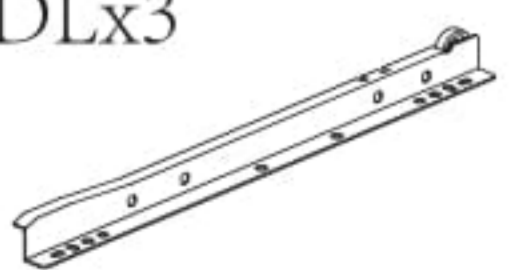

DRx3

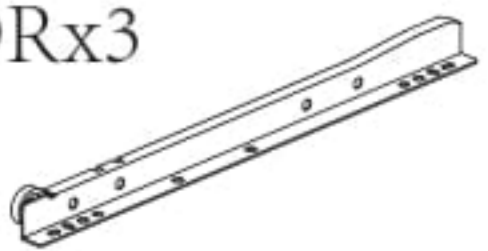

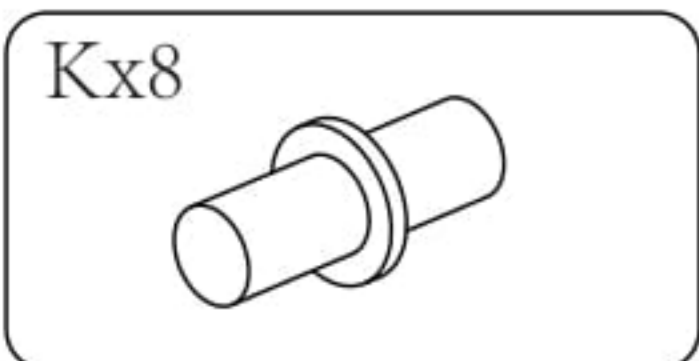
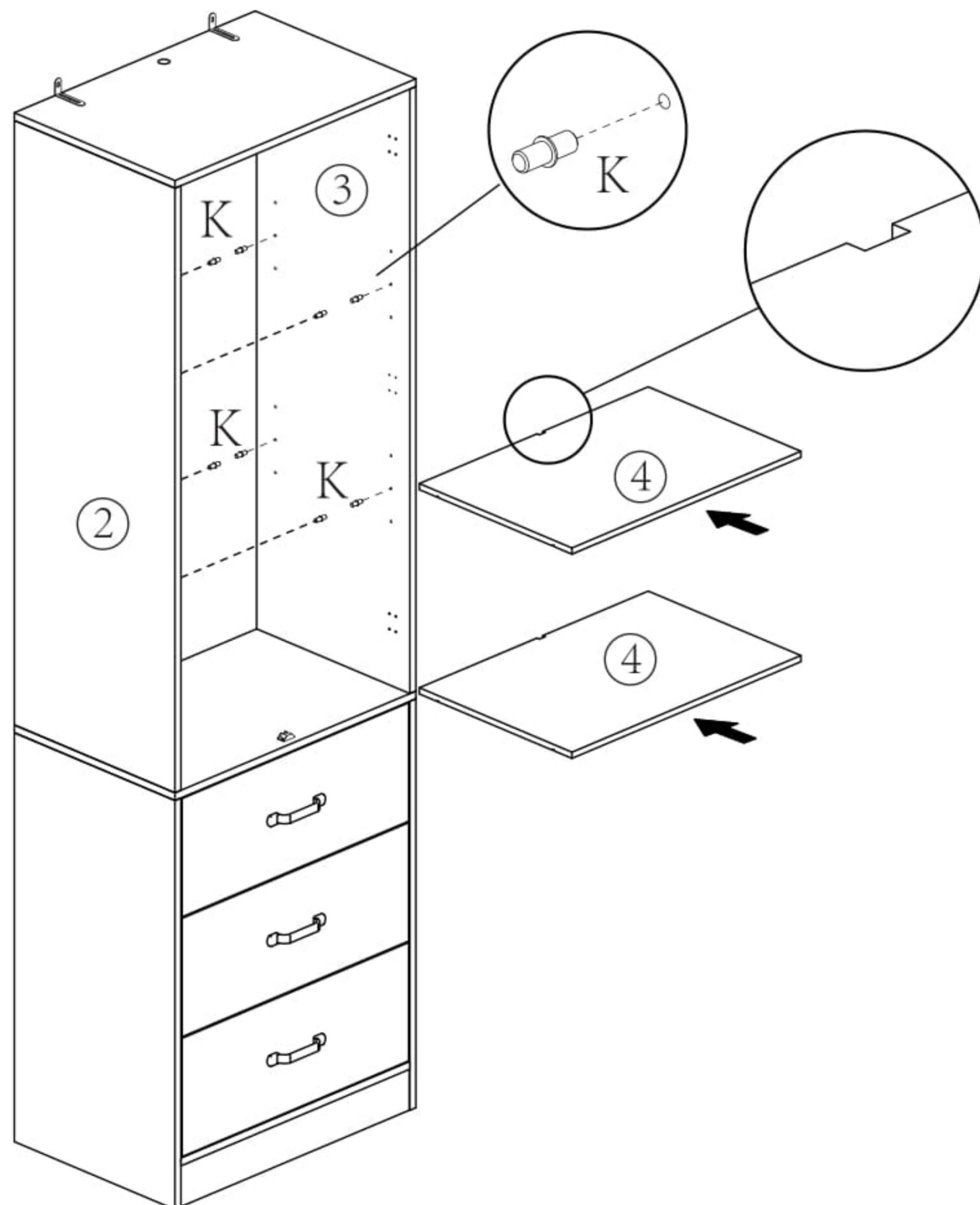
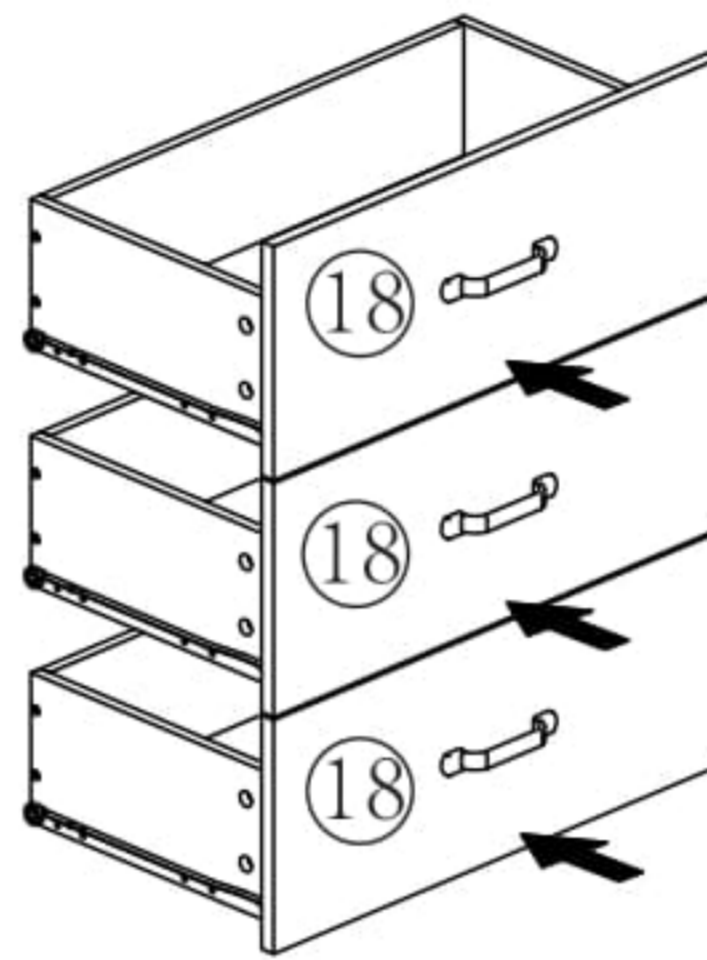
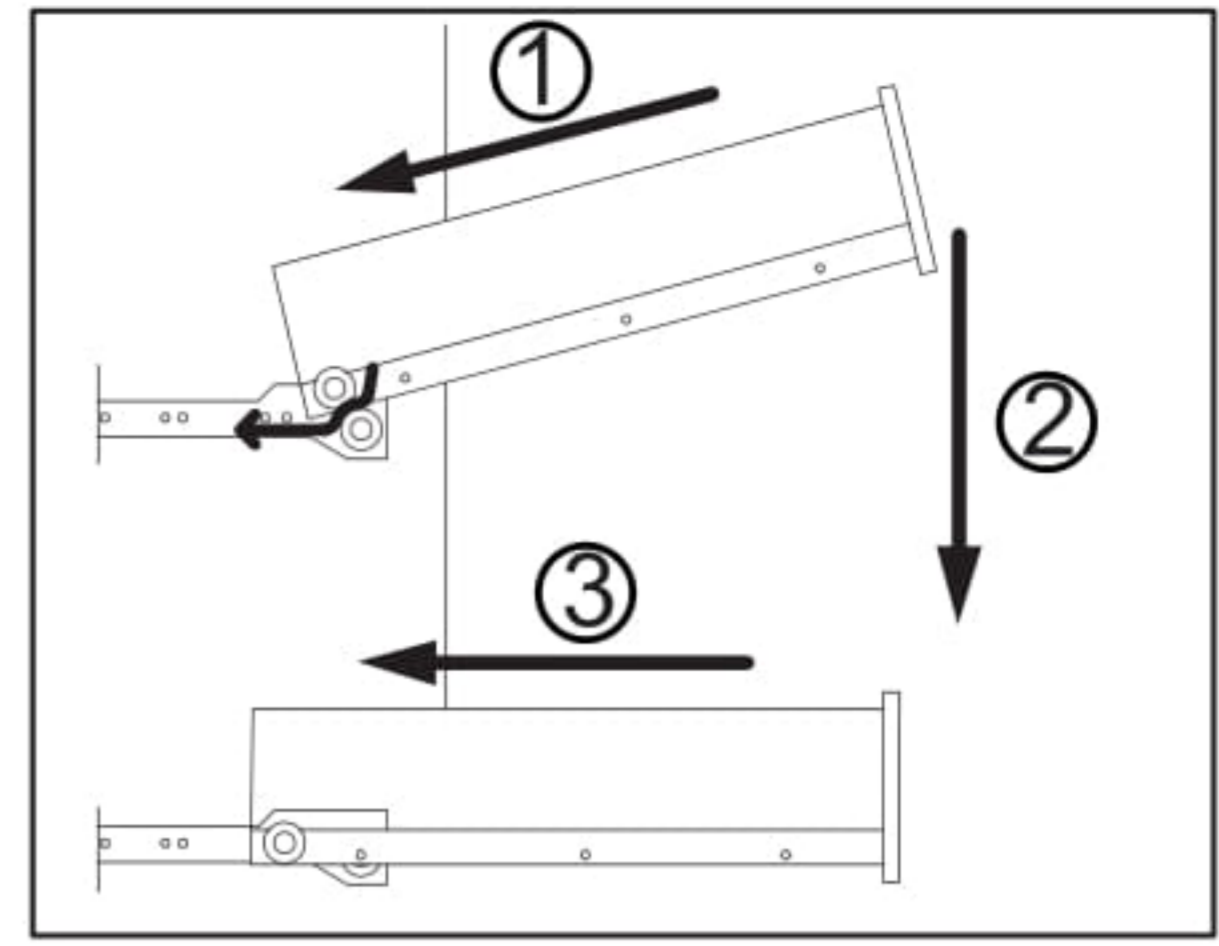
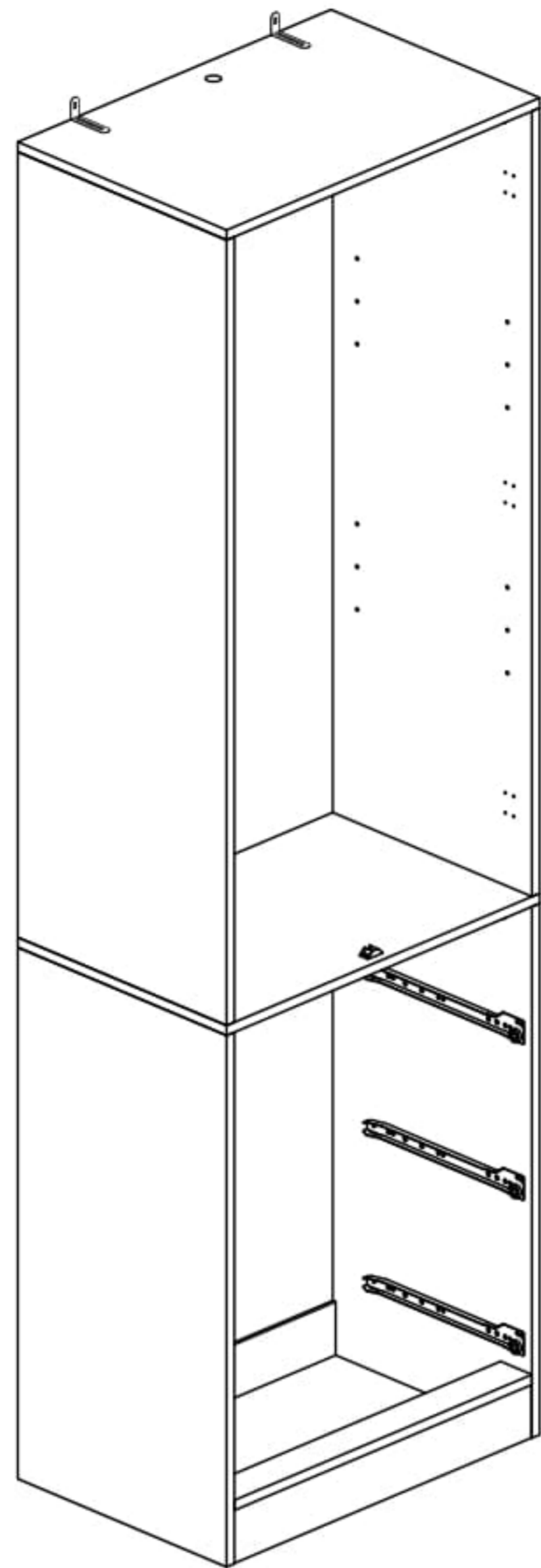

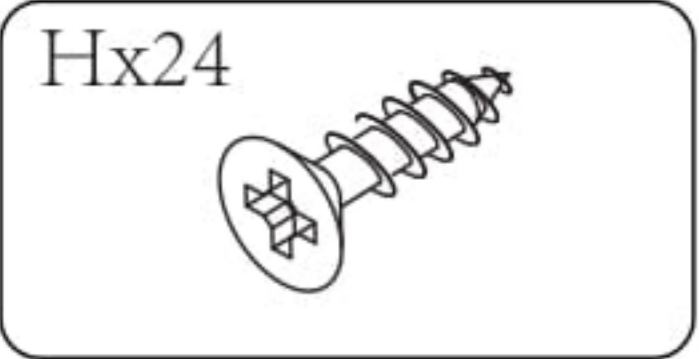
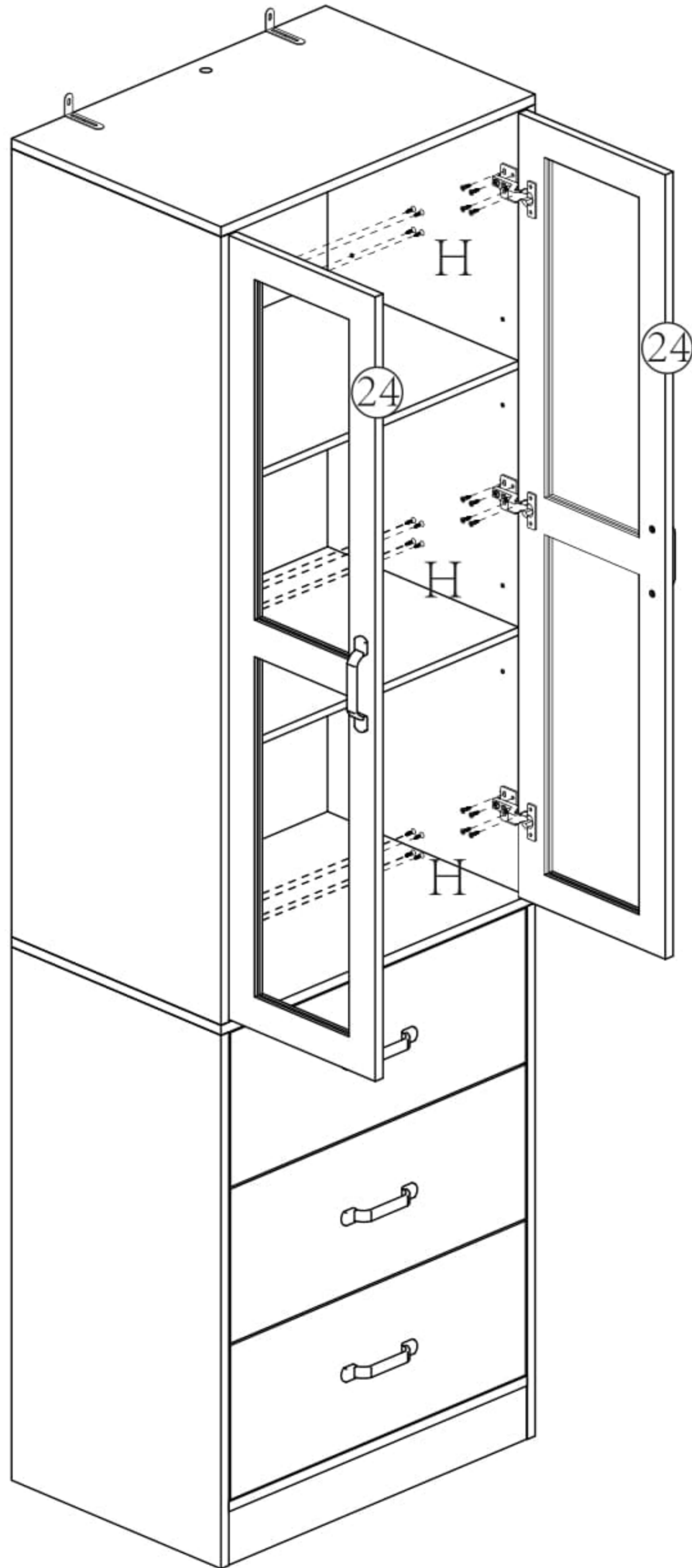
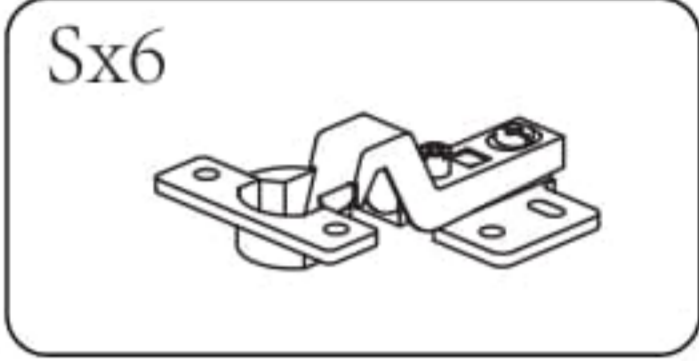
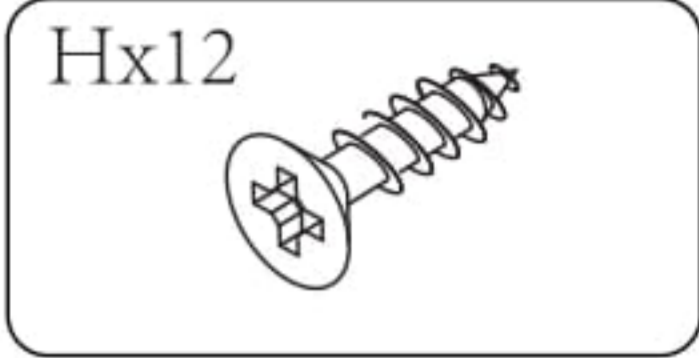
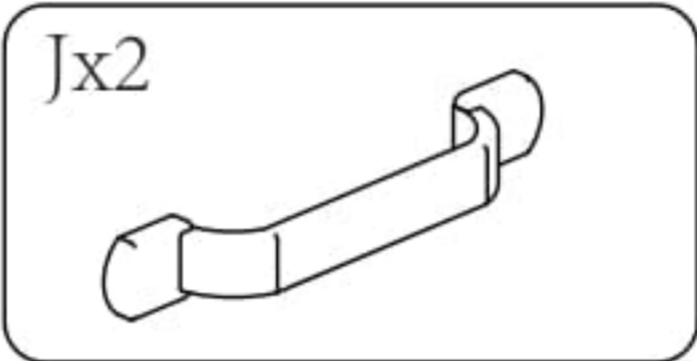
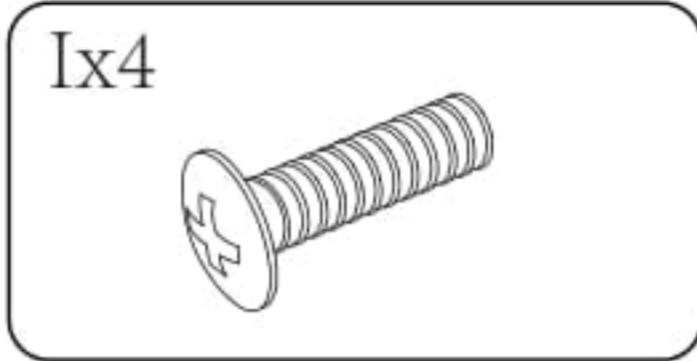
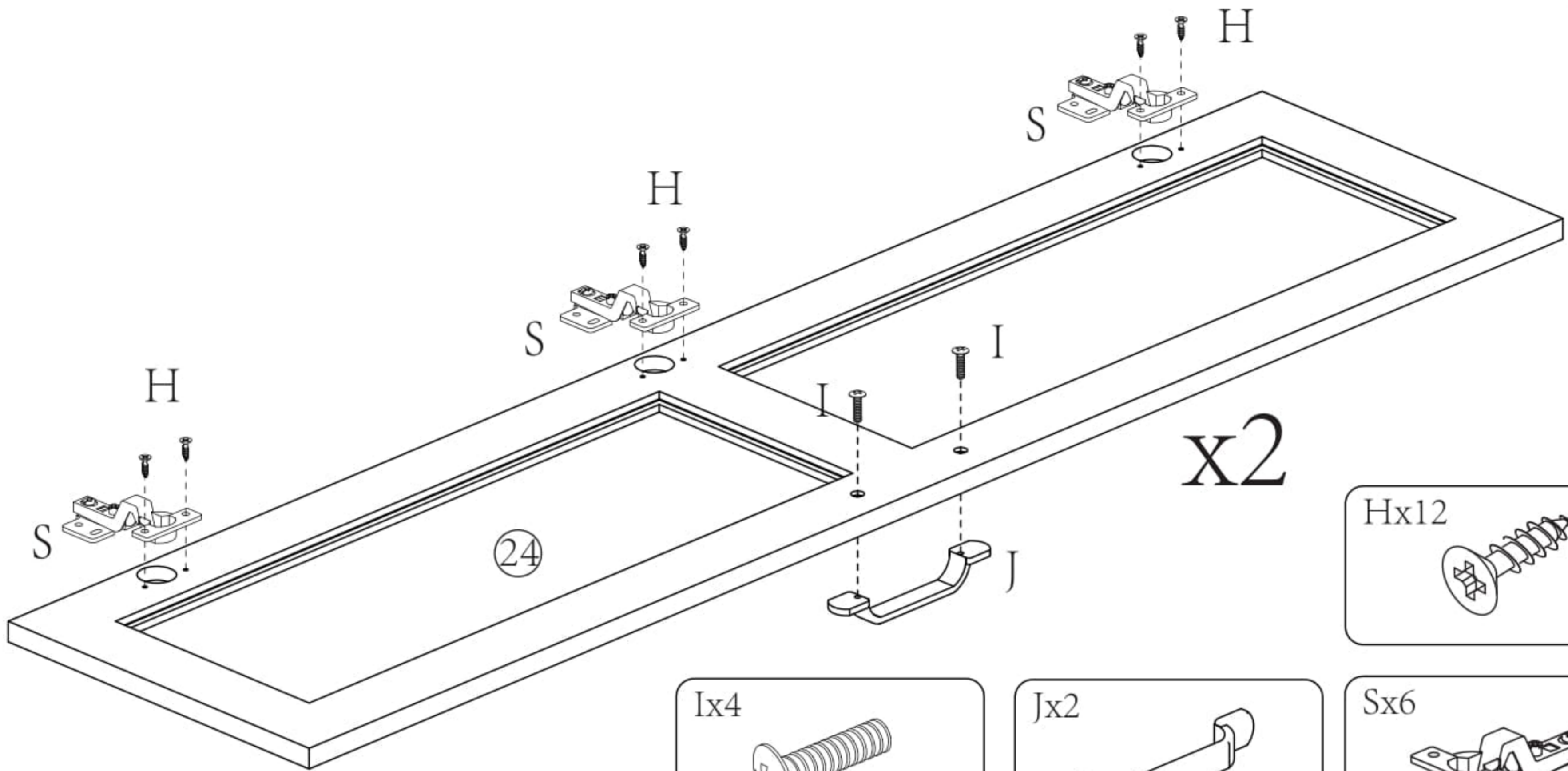

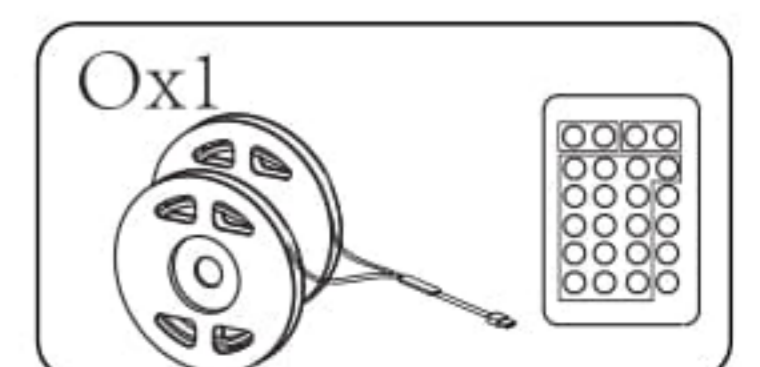
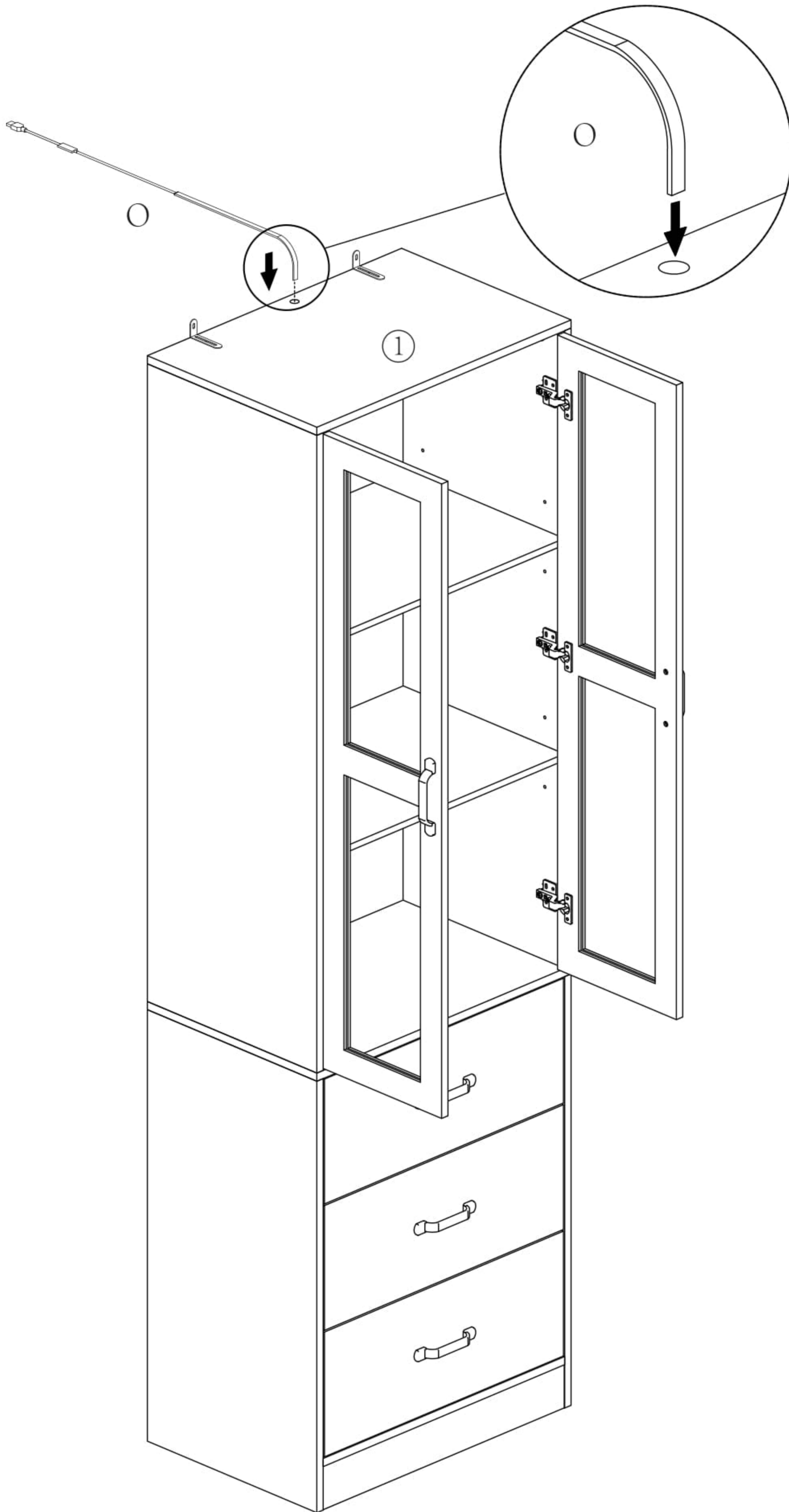

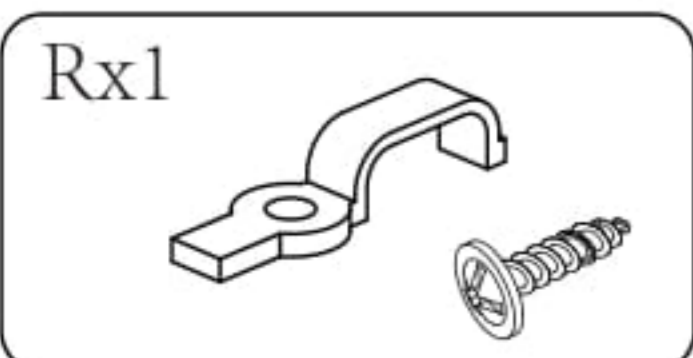
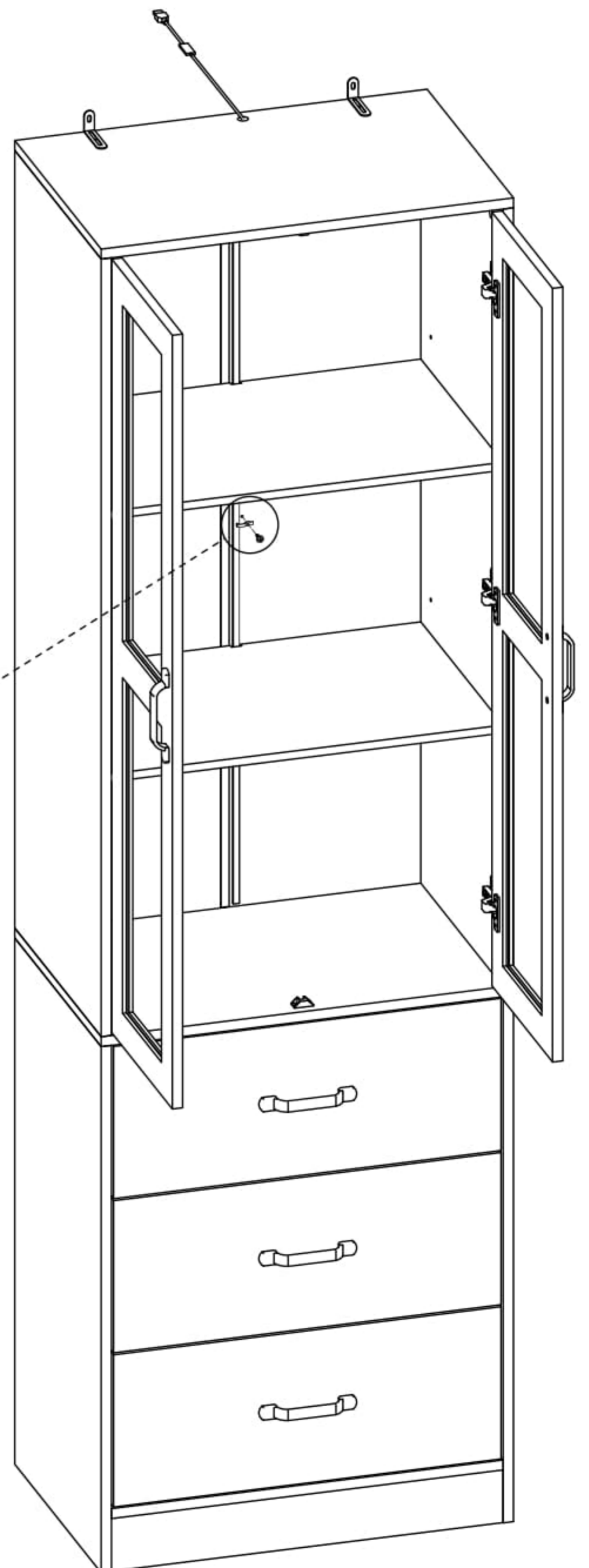
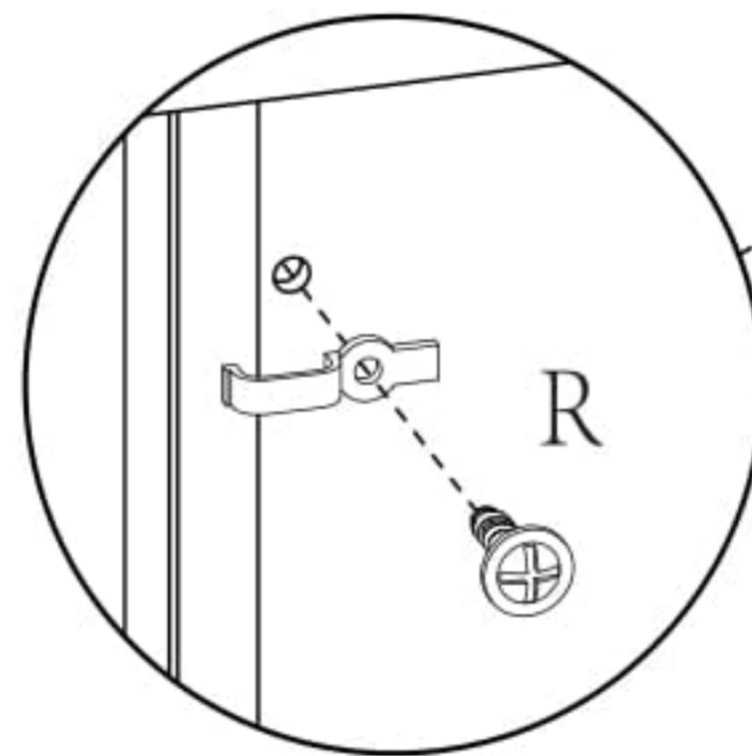
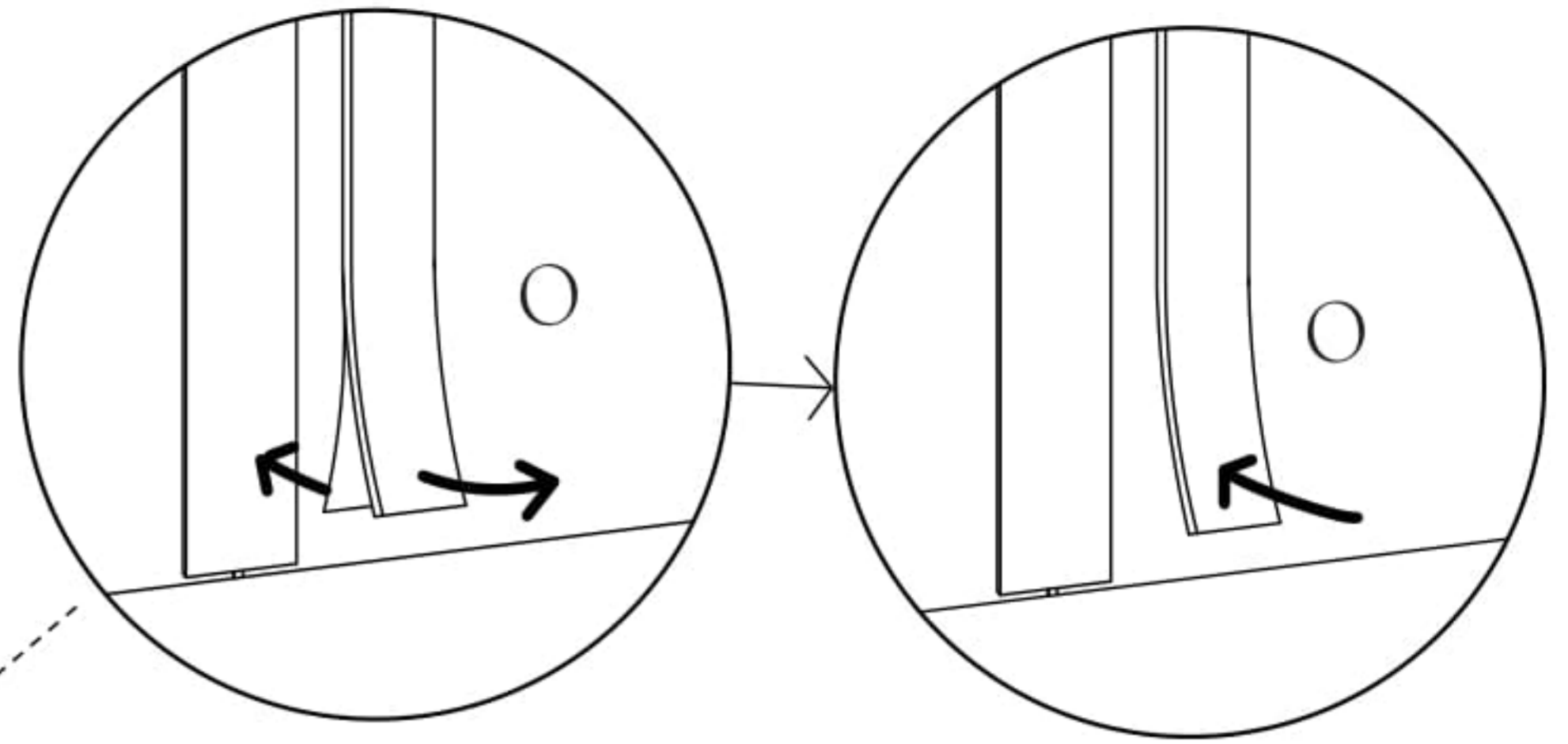
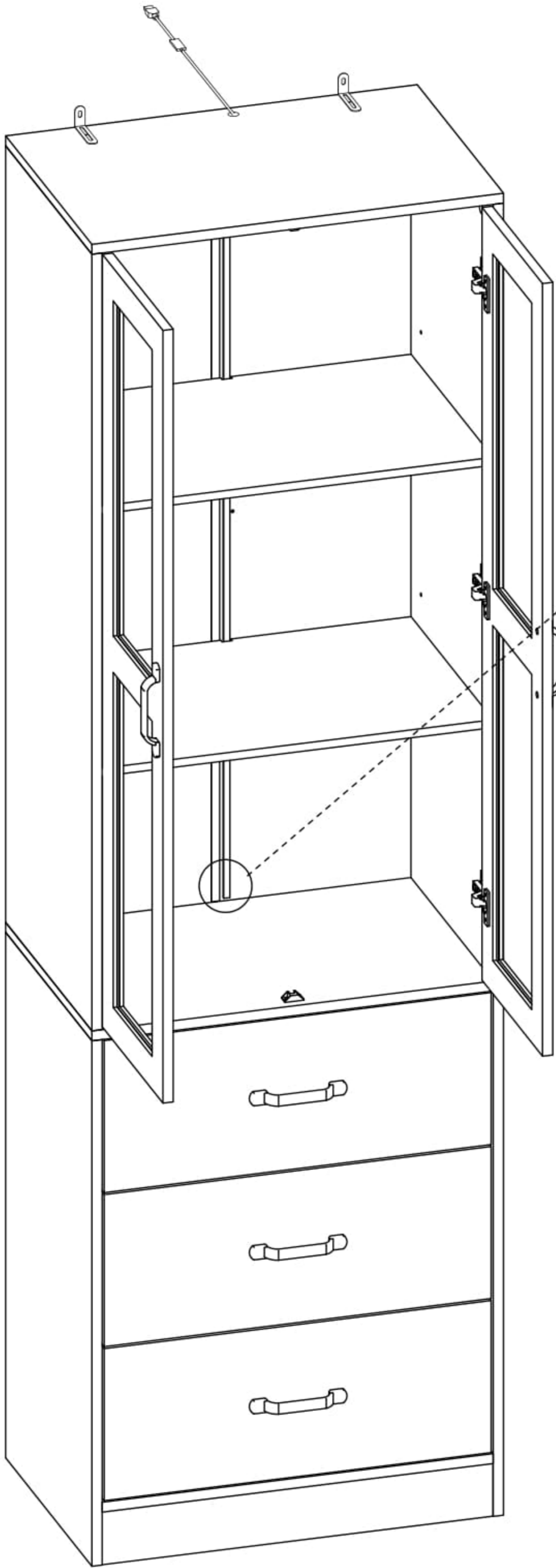

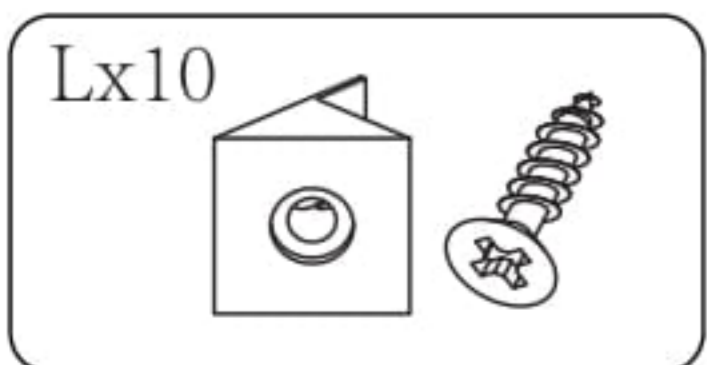
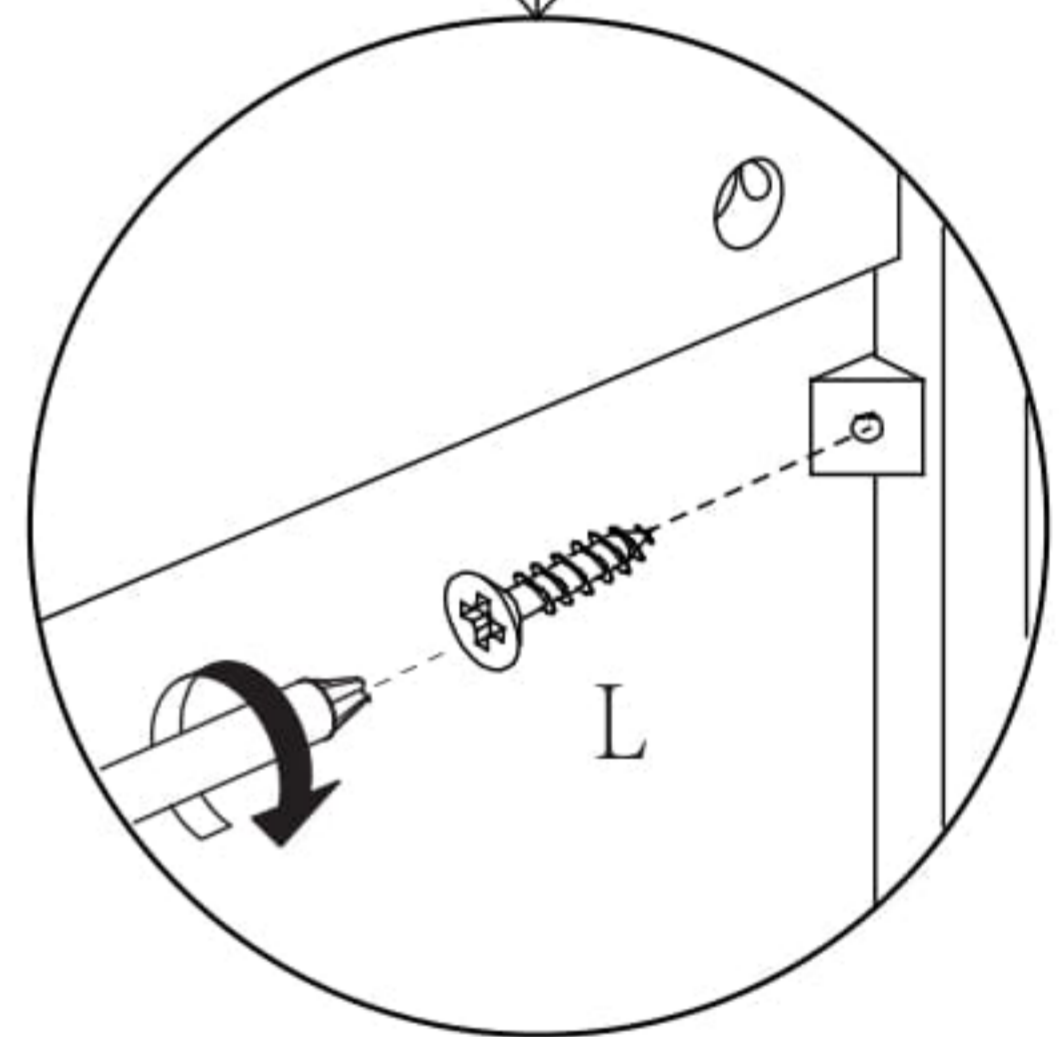
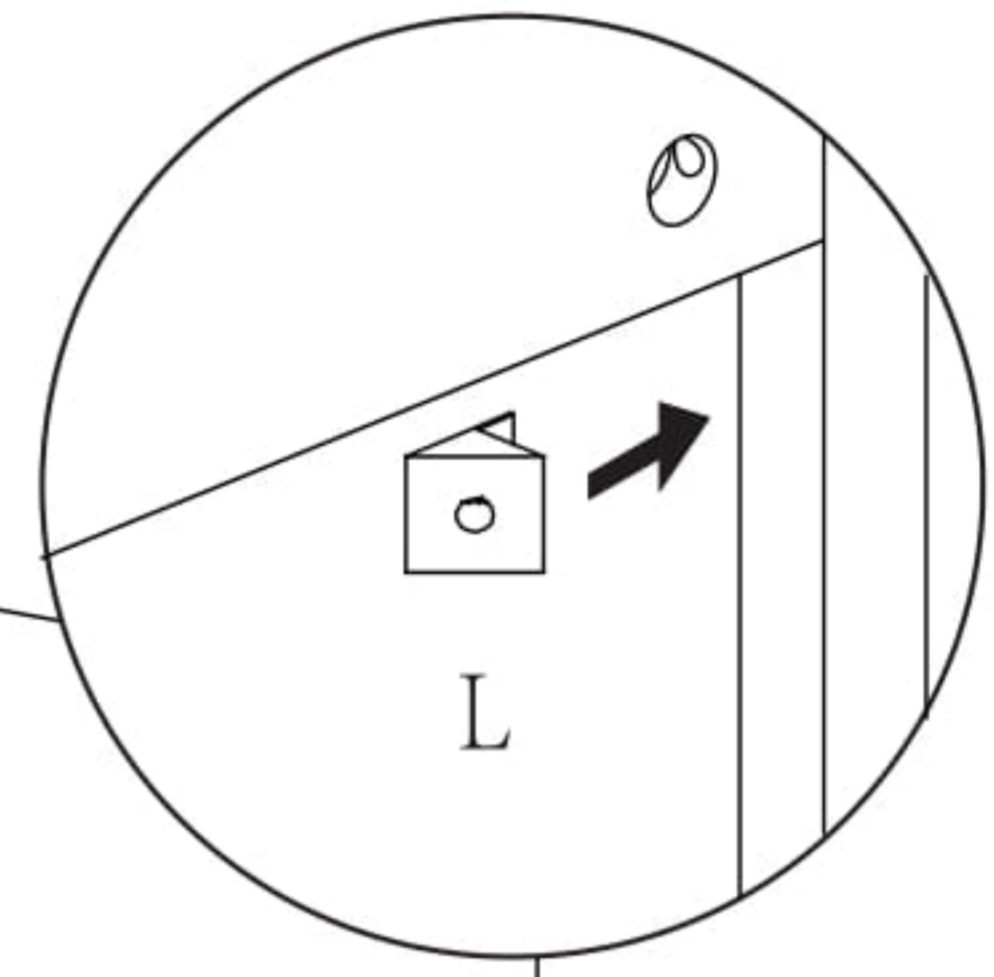
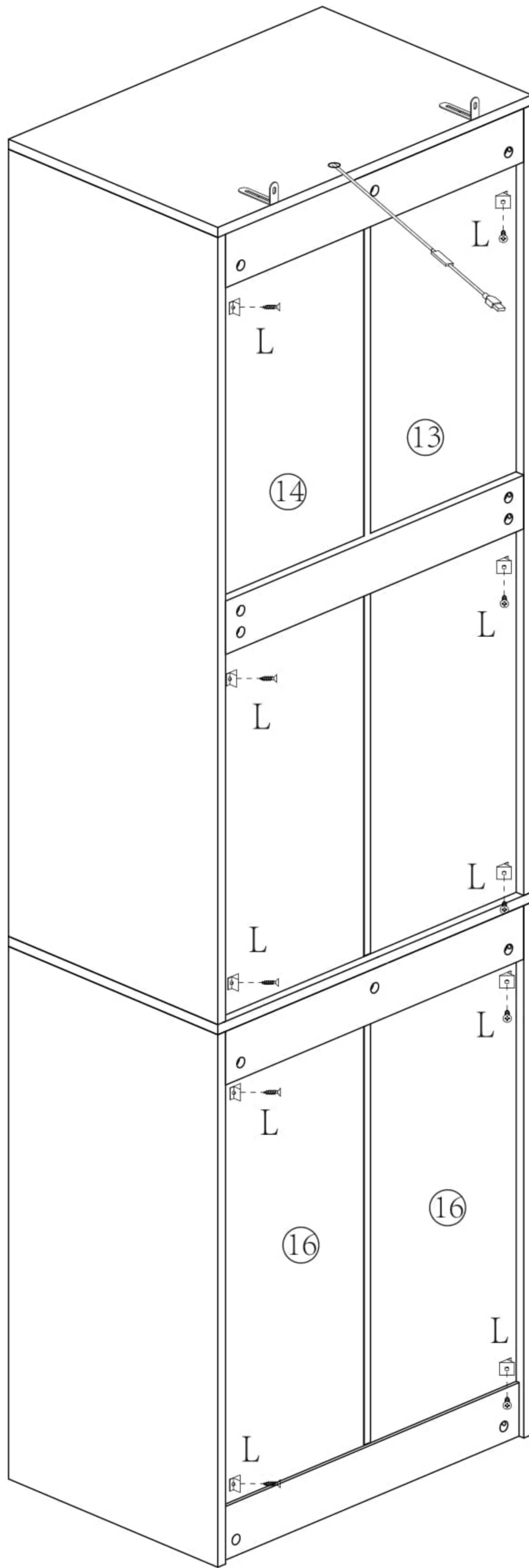

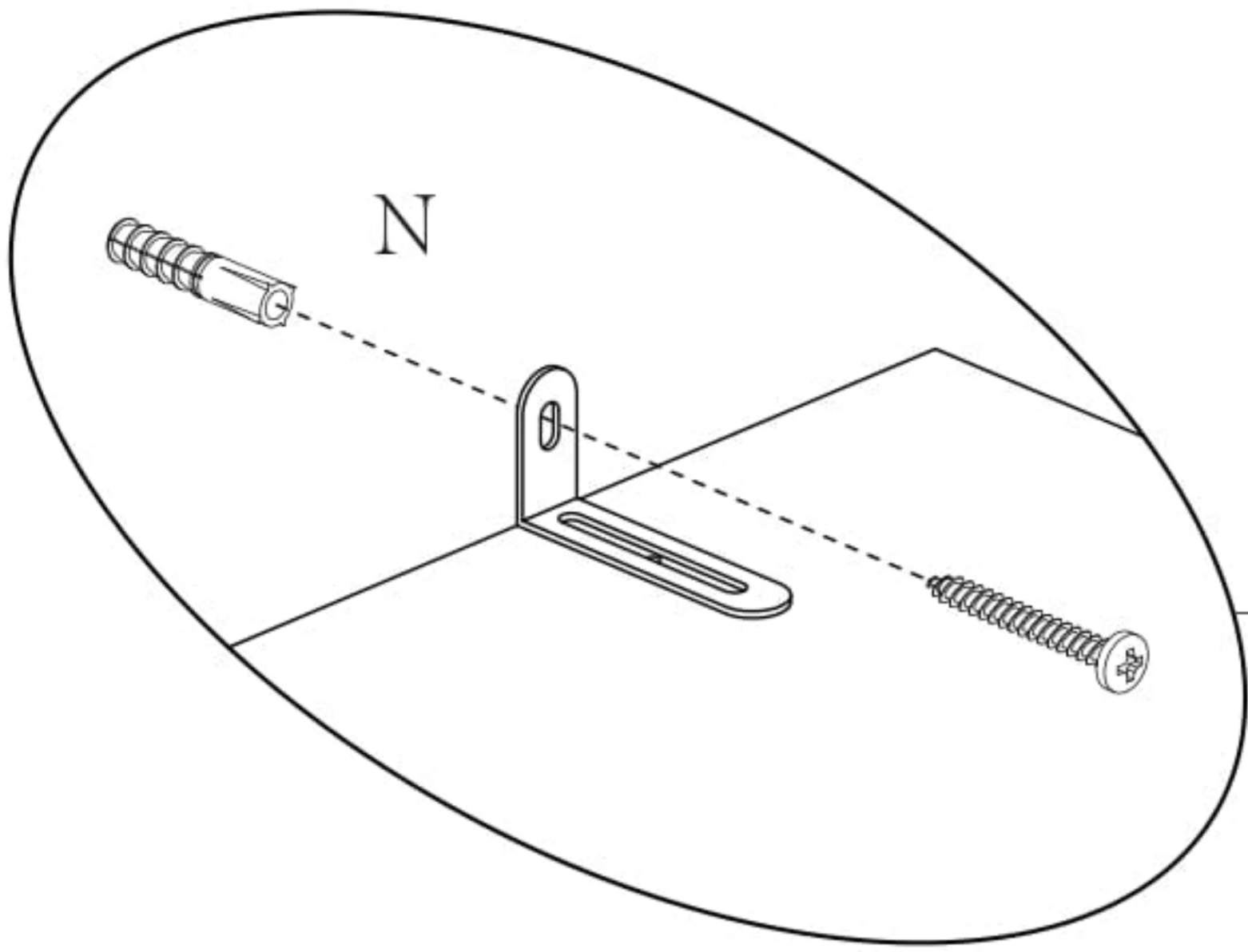

Wand  
Wall  
Muro  
Mur  
Pared

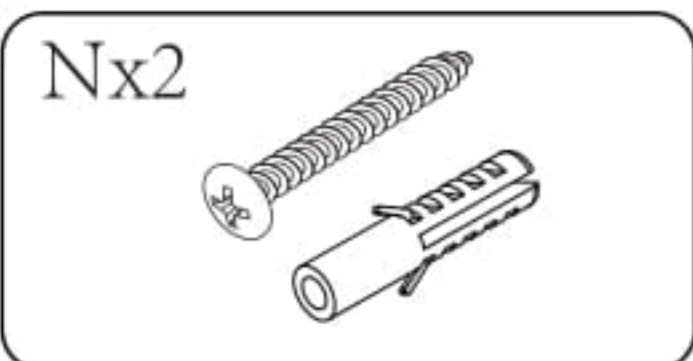

DE

Wenn es sich um eine Massivwand handelt, verwenden Sie bitte Dehnungs- und selbstschneidende Schrauben; wenn es sich um eine Holzwand handelt, verwenden Sie nur selbstschneidende Schrauben. Bitte ziehen Sie die Schrauben nicht zu fest an.

EN

If it is a solid wall, please use expansion and self-tapping screws; if it is a wooden wall, only use self-tapping screws. Please do not over-tighten the screws.

IT

Se è un muro solido, si prega di utilizzare viti ad espansione e autoperforanti; se è un muro di legno, utilizzare solo viti autoperforanti. Si prega di non stringere eccessivamente le viti.

FR

Si le mur est massif, veuillez utiliser des chevilles à expansion et des vis autotarau-deuses ; s'il s'agit d'un mur en bois, utilisez uniquement des vis autotarau-deuses. Veuillez ne pas trop serrer les vis.

ES

Si es una pared sólida, utilice tornillos de expansión y autorroscantes; si es una pared de madera, utilice solo tornillos autorroscantes. No apriete demasiado los tornillos.

28

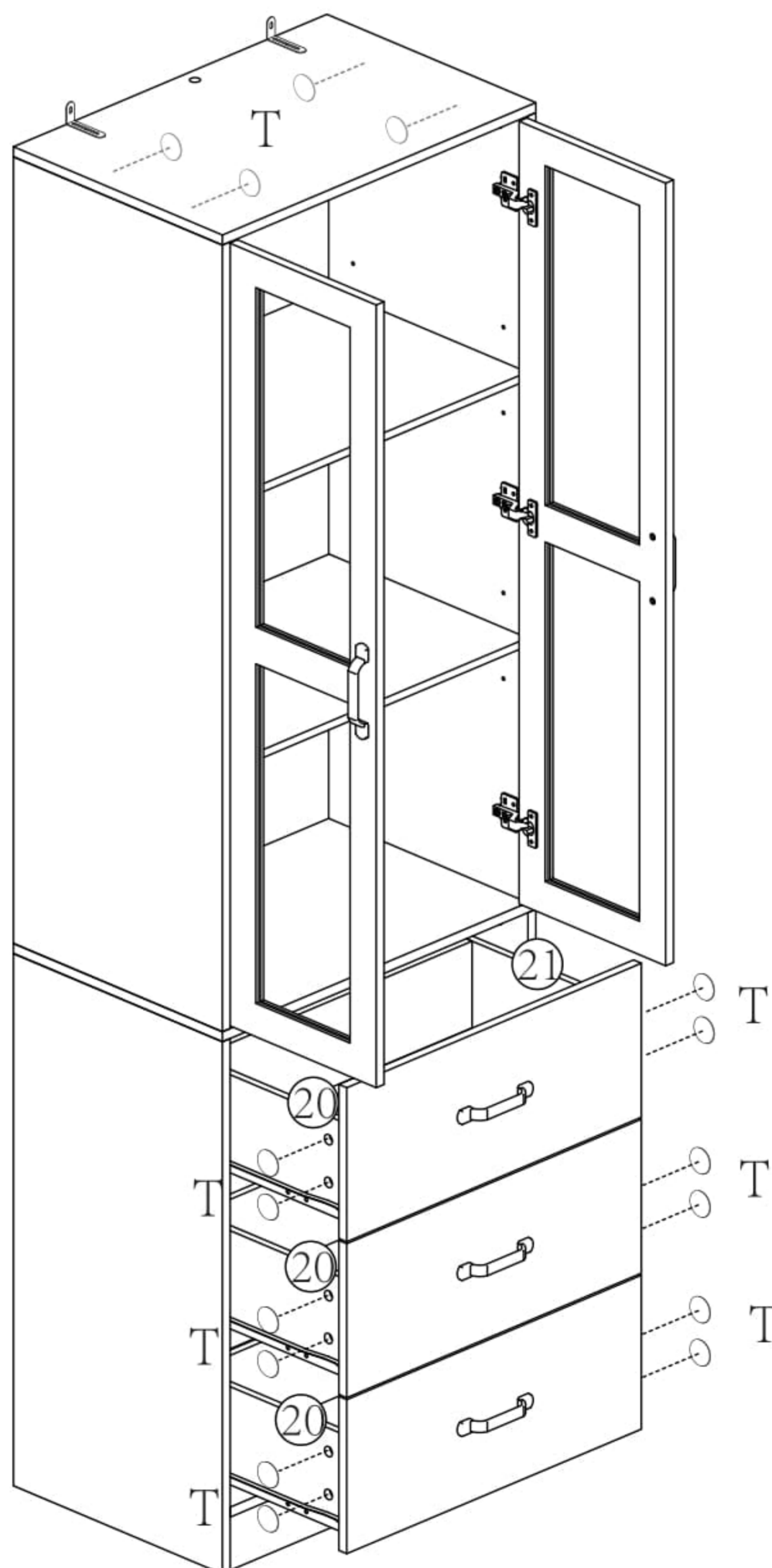
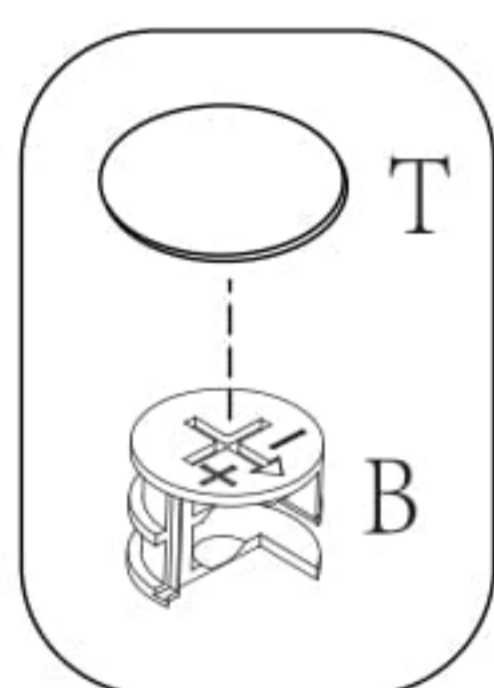

Tx16



[DE]  
HINWEIS: Der Akku in der Fernbedienung erfordert, dass Sie Sie selbst kaufen und installieren.

[EN]  
NOTE: The battery in the remote control requires you to purchase and install it yourself.

[FR]  
REMARQUE : La pile de la télécommande est requise, que vous les achetez et les installez vous-même.

[IT]  
NOTA: la batteria del telecomando richiede, che li acquisti e li installi tu stesso.

[ES]  
NOTA: La batería del control remoto requiere, que los compre e instale usted mismo.

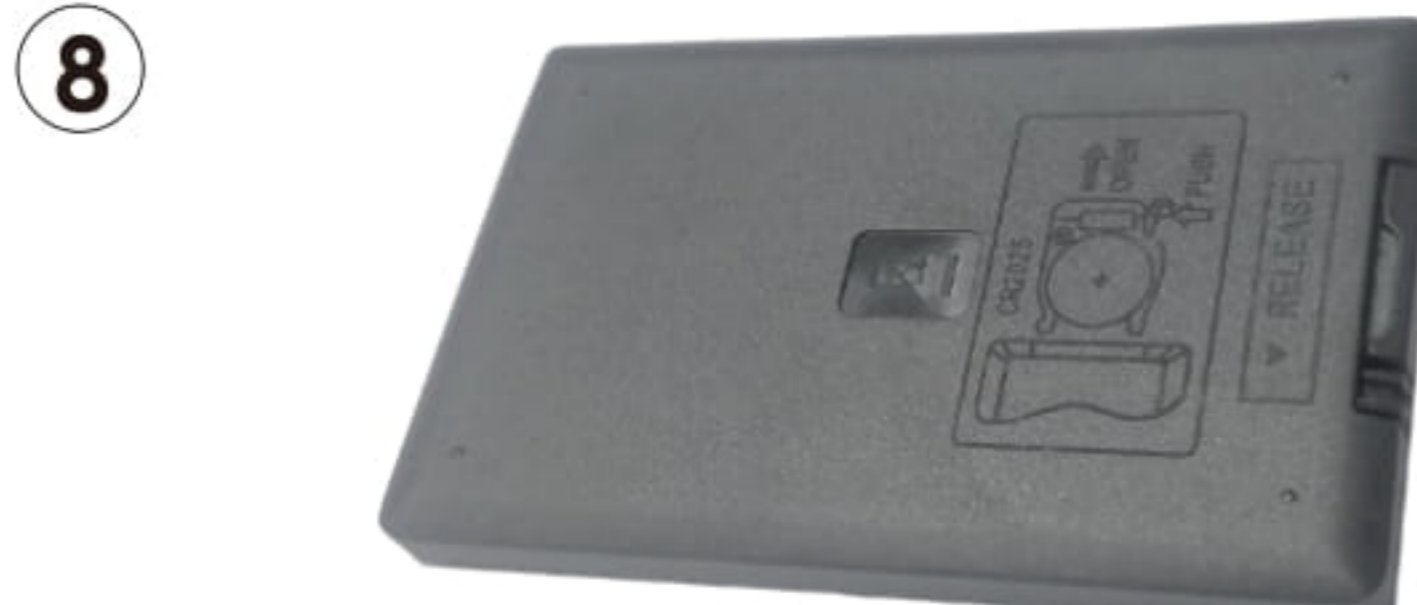
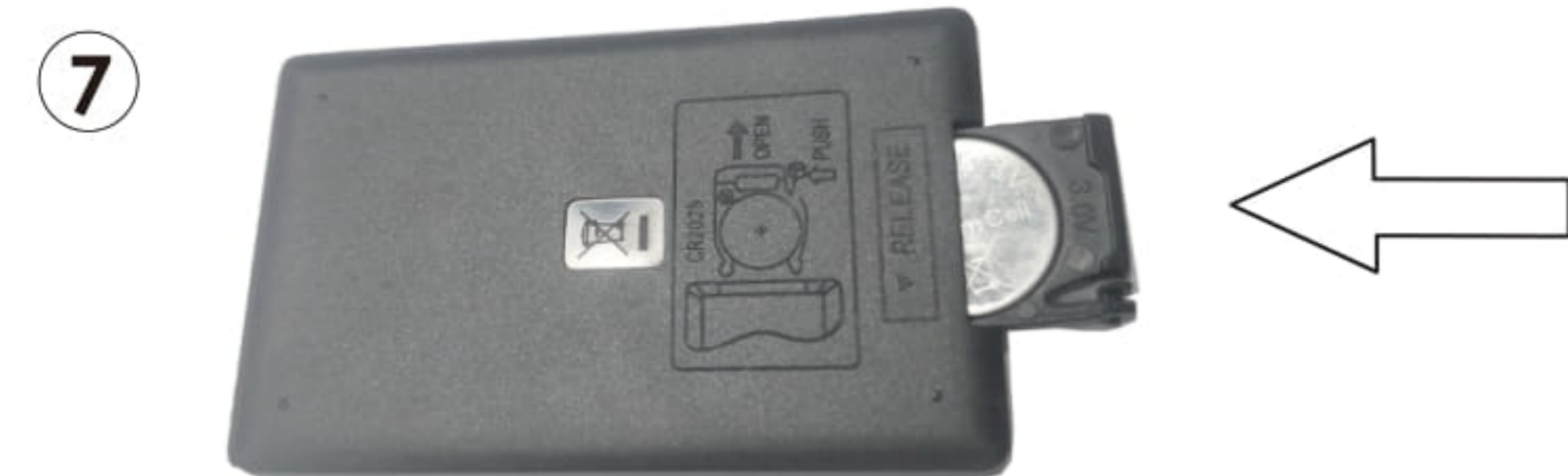
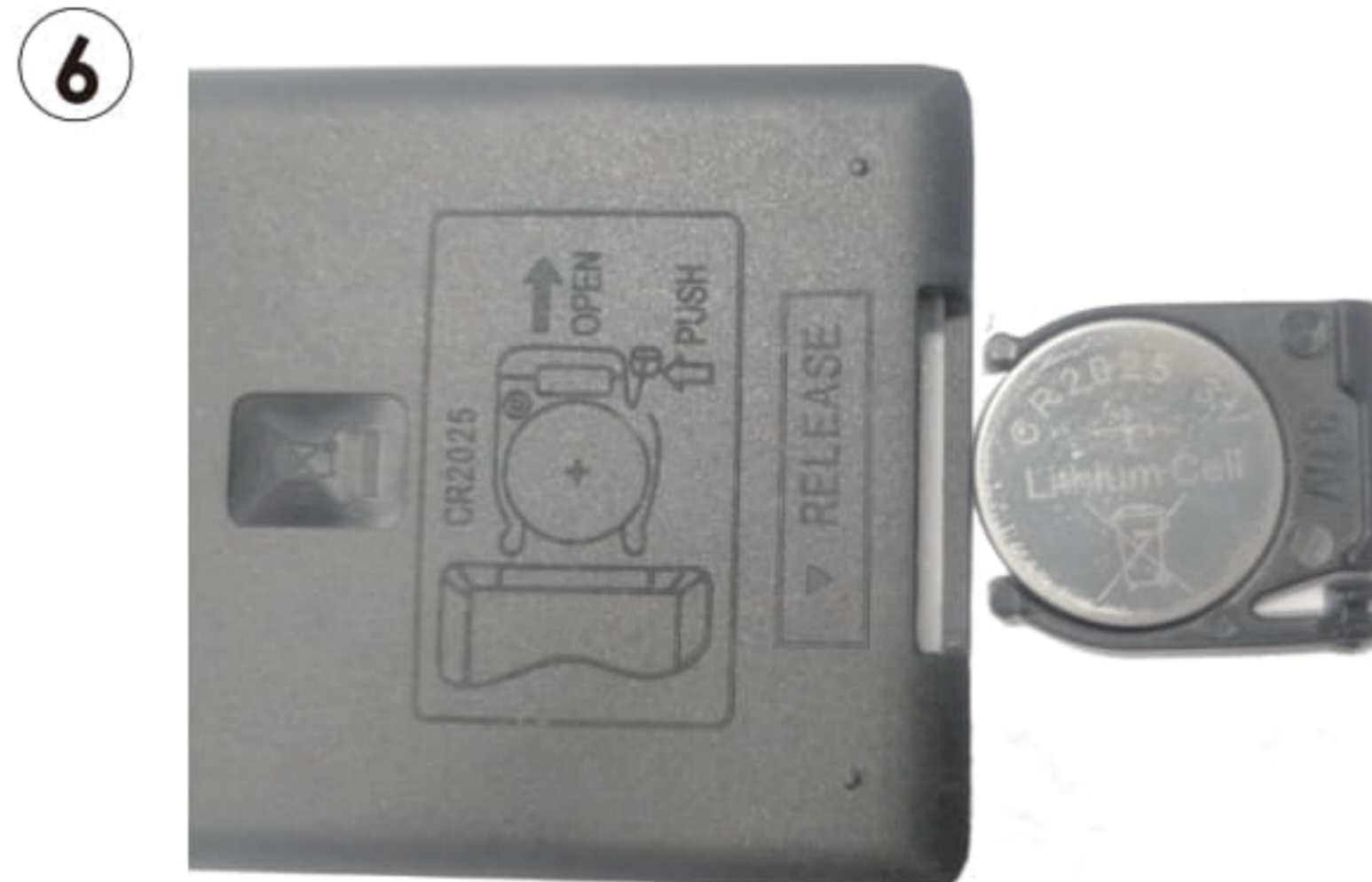
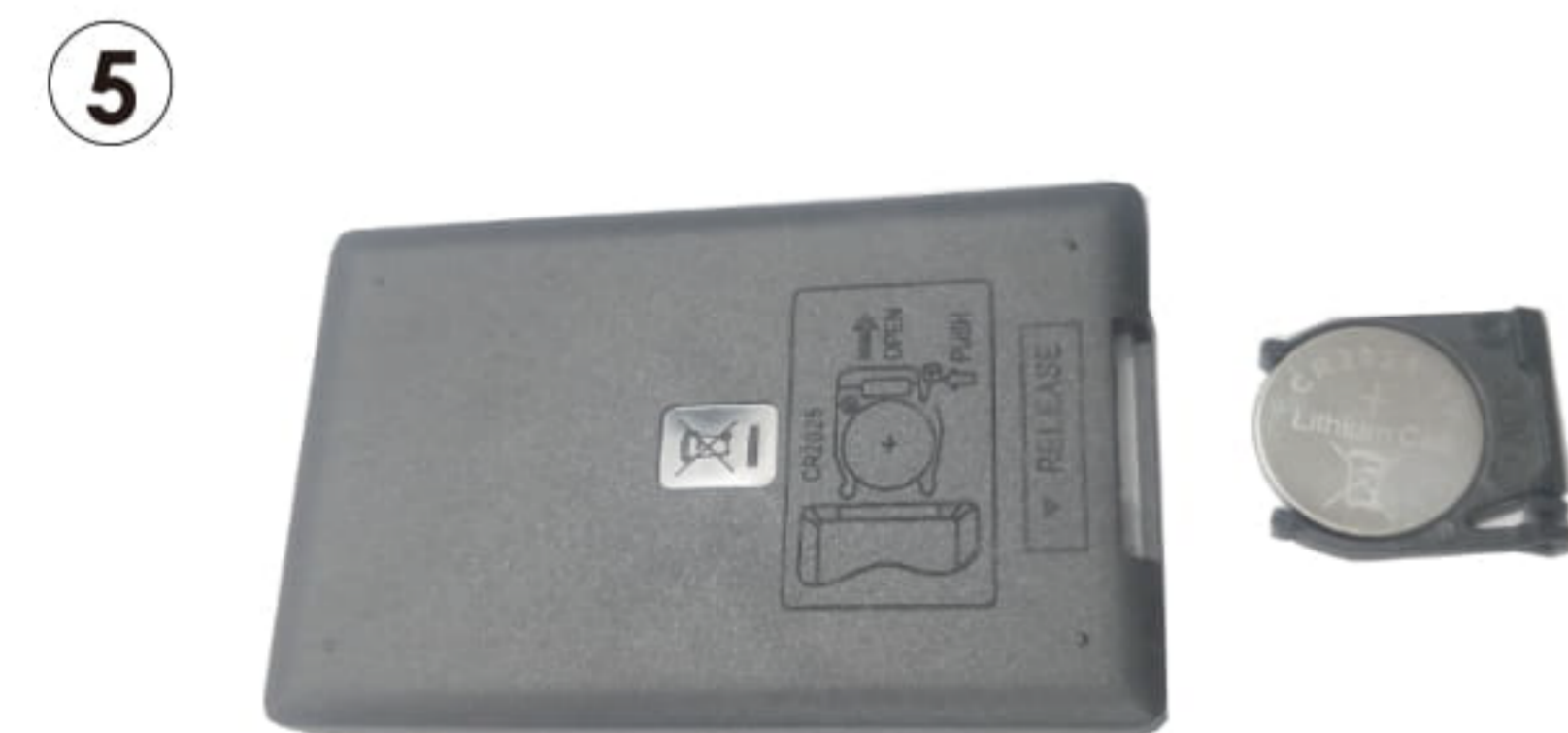
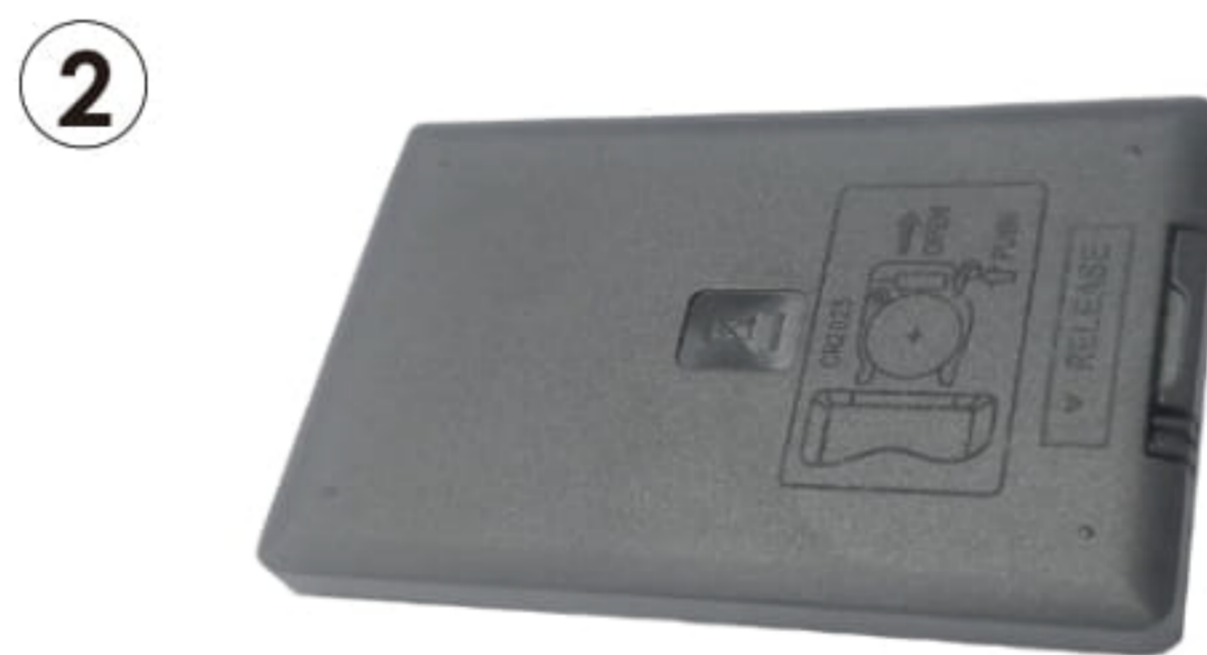



## VERIFICATION OF CONFORMITY

EU - The Radio Equipment Directive (RED) -  
No. : CTB231227005REX-ZS

**Applicant** : Dongguan Huima Synthetic Electronics Co.,Ltd  
**Address** : 3rd Floor, Bingding A, No.1 Jiangxing Road, Huangjiang Village, Huangjiang Town, Dongguan City, Guangdong Province, China  
**Manufacturer** : Dongguan Huima Synthetic Electronics Co.,Ltd  
**Address** : 3rd Floor, Bingding A, No.1 Jiangxing Road, Huangjiang Village, Huangjiang Town, Dongguan City, Guangdong Province, China  
**Product** : Baolian Lamp 2.4G Bluetooth LED Controller  
**Trade Name** : N/A  
**Model(s)** : HM-LY-2.4G, HM-LY-3K008, HM-LY-3K009, HM-LY-2.4G001, HM-LY-2.4G002, HM-LY-2.4G003

The tests that base on the above designated product Complies with the essential requirements of Directive 2014/53/EU relating to Electrical Equipment designed for use within Radio and telecommunications terminal equipment.

The test results apply only to the particular sample tested and the applicative tests carried out. The CE markings as shown below can be affixed on product after manufacturer carry out all stipulation activities integrally of above mentioned Regulation (Directive) and preparation of necessary technical documentation as well as the conformity declaration.

This statement is based on a single evaluation of sample of above mentioned product. It does not imply an assessment of the whole production process.

Other relevant Regulation (Directive) requirement have to be observed.



Bin Mei (Director)

Jan. 19, 2024



Shenzhen CTB Testing Technology Co., Ltd

Add: 1&2/F., Building A, No.28, Xinhe Road, Xinqiao, Xinqiao Street, Bao'an District, Shenzhen, Guangdong, China.

Web: [www.ctb-lab.net](http://www.ctb-lab.net)

Tel: 4008-707-283

Email: [ctb@ctb-lab.net](mailto:ctb@ctb-lab.net)



## VERIFICATION OF CONFORMITY

EU - The Radio Equipment Directive (RED) -

No. : CTB231227005REX-ZS

| Category                            | Test Standards   | Test Report No. |
|-------------------------------------|--|-----------------|
| Health and Safety<br>(Article 3.1a) | EN 61347-2-11:2001+A1:2019 used in conjunction with<br>EN 61347-1:2015+A1:2021 | CTB231227086RSX |
|                                     | EN 62479:2010<br>EN 50663:2017   | CTB231227006RHX |
| EMC<br>(Article 3.1b)               | ETSI EN 301 489-1 V2.2.3 (2019-11)   | CTB231227005REX |
|                                     | Draft ETSI EN 301 489-17 V3.2.6 (2023-06)                                      |                 |
| Radio Aspects<br>(Article 3.2)      | ETSI EN 300 328 V2.2.2 (2019-07)   | CTB231227004RFX |

The tests that base on the above designated product Complies with the essential requirements of Directive 2014/53/EU relating to Electrical Equipment designed for use within Radio and telecommunications terminal equipment.

The test results apply only to the particular sample tested and the applicative tests carried out. The CE markings as shown below can be affixed on product after manufacturer carry out all stipulation activities integrally of above mentioned Regulation (Directive) and preparation of necessary technical documentation as well as the conformity declaration.

This statement is based on a single evaluation of sample of above mentioned product. It does not imply an assessment of the whole production process.

Other relevant Regulation (Directive) requirement have to be observed.



Bin Mei (Director)

Jan. 19, 2024



**Shenzhen CTB Testing Technology Co., Ltd**

Add: 1&2/F., Building A, No.26, Xinhe Road, Xinqiao, Xinqiao Street, Bao'an District, Shenzhen, Guangdong, China.

Web: [www.ctb-lab.net](http://www.ctb-lab.net)

Tel: 4008-707-283

Email: [ctb@ctb-lab.net](mailto:ctb@ctb-lab.net)