

VIVOHOME

**THANK
YOU!**

NOTE:

To continuously improve its products, VIVOHOME reserves the right to modify this information without prior notification.

For any questions regarding assembly, please watch the video on the product page or contact our customer service. Our customer service will gladly assist you with any additional questions, comments, or concerns.

Thank you for using VIVOHOME products in your home!

Thank You for Purchasing from

VIVOHOME

Made in China

VIVOHOME

HOW-TO

USER MANUAL

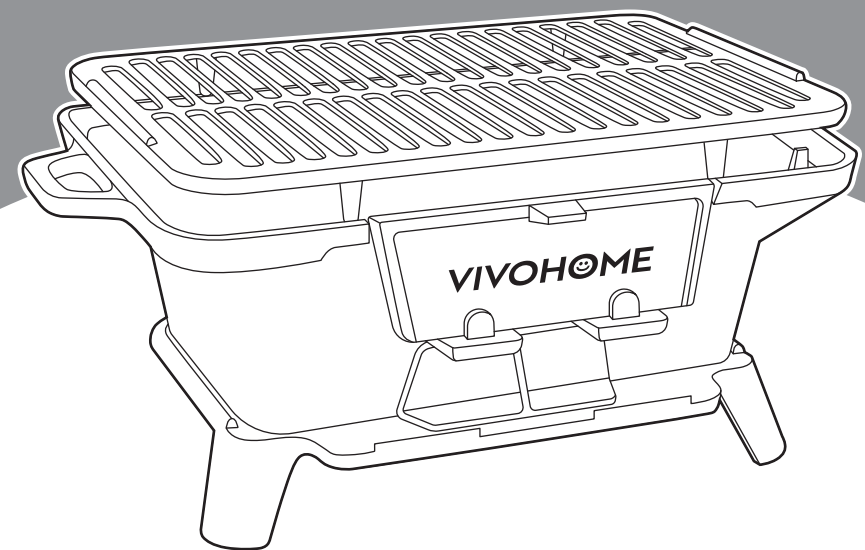

Rectangle Cast Iron Grill

Assembly is EASY!

**WE WANT
YOU TO
ENJOY LIFE
AT HOME**



GO TO THE PRODUCT LISTING PAGE
FOR AN INSTRUCTIONAL VIDEO!

CONTENTS

Parts List and Diagram.....	1
Assembly Steps.....	2
Grill Cleaning.....	5
Grill Maintenance and Storage.....	5
Warranty.....	6

Parts List and Diagram

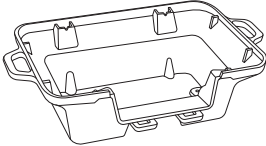
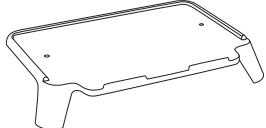
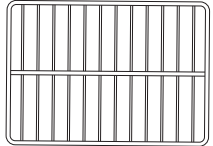
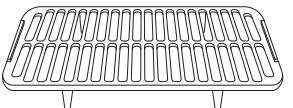
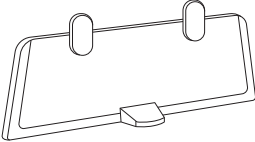
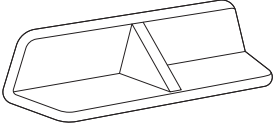

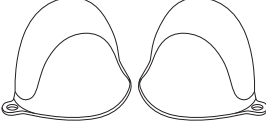
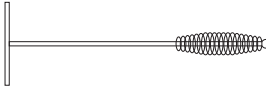
Item No.	Reference Image	Qty.	Item No.	Reference Image	Qty.
1	 Main Body	x1	2	 Base	x1
3	 Ash Screen	x1	4	 Double-Sided Grill Net	x1
5	 Front Fire Gate	x1	6	 Air-Regulating Door	x1
7	 Screw	x2	8	 Butterfly Nut	x2
9	 Silicone Gloves	x1	10	 Ash Poker	x1

Assembly Steps

STEP 1 1 x 1 pc. 2 x 1 pc. 7 x 2 pcs. 8 x 2 pcs.

Stand the base (2) upright and align the holes to attach the body (1). Assemble them using screws (7) and butterfly nuts (8).

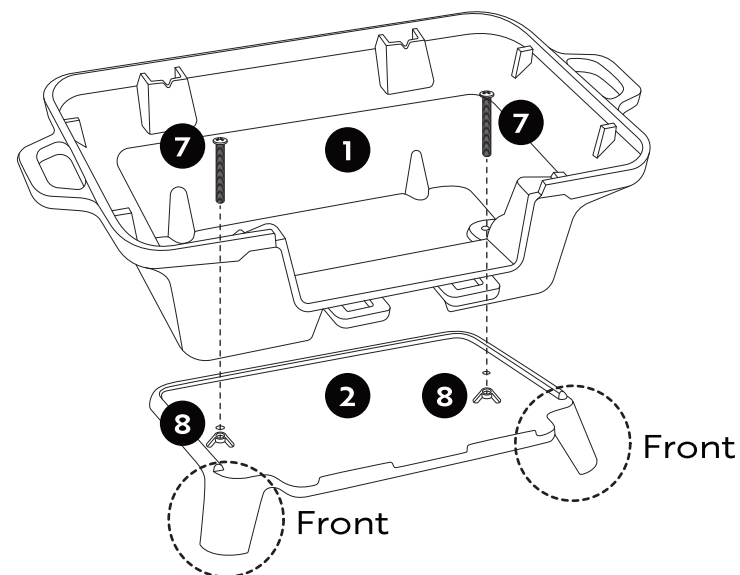

STEP 2 3 x 1 pc.

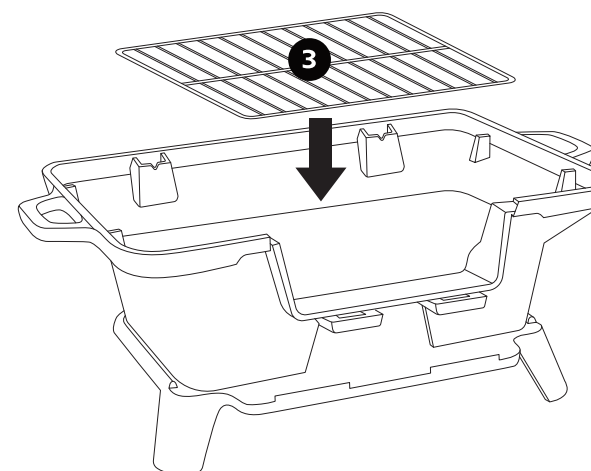
Insert the ash screen (3).



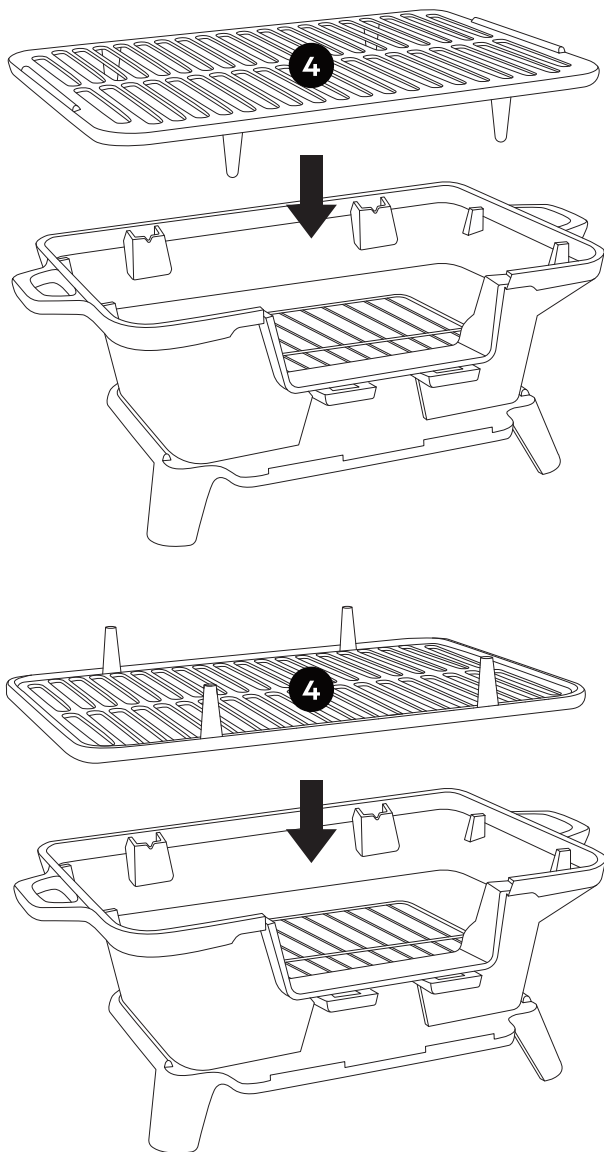

STEP 3 4 x 1 pc.

Stand the grill net (4) upright or upside down to adjust the grilling height.

STEP 4 5 x 1 pc. 6 x 1 pc.

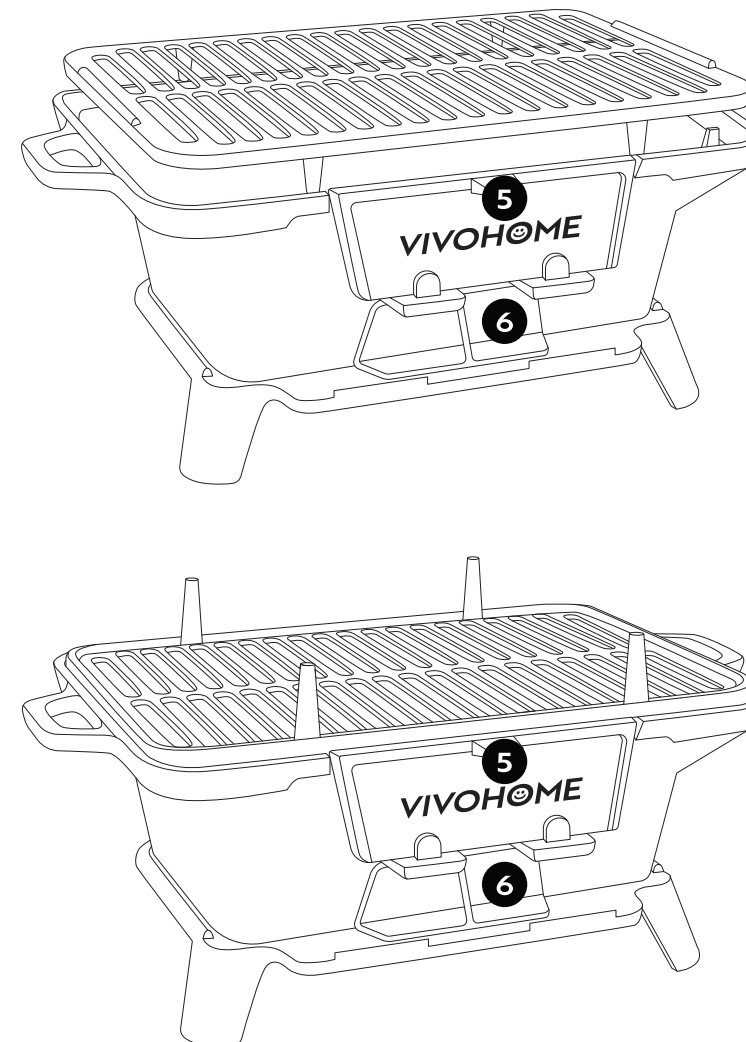
Attach the front fire gate (5) and the air-regulating door (6).





Upon receiving the product, be sure to clean and season it with oil for maintenance.

1. Clean the grill thoroughly and dry the surface completely. You can either wipe off any moisture or heat the grill to ensure it is completely dry.
2. Pour a small amount of cooking oil into a cup or bowl. Use chopsticks or tongs to pick up a paper towel and dip it into the oil, then evenly coat the interior of the stove, making sure to cover every corner. Repeat this process 3-5 times, and your stove will be ready for use.



1. When not in use, clean and dry the grill thoroughly, apply oil immediately, and store it in a well-ventilated, cool, and dry place.
2. After each use and cleaning, dry the surface completely by wiping or heating. Apply a thin layer of cooking oil to help extend the lifespan of the cast iron grill.
3. If rust occurs due to improper use or maintenance, remove the rust and follow steps 1 and 2 for proper care.

Take care to prevent burns when using silicone gloves.



The VIVOHOME warranty program is our commitment to you. We are committed to providing you with a high-quality product that meets your needs and expectations. To demonstrate our confidence in the durability and performance of our products, we offer the following warranty.

WARRANTY COVERAGE

This warranty applies to all orders, purchases, or use of products sold only by VIVOHOME and is valid for 1 year from the purchase date. Please note, this warranty only covers the original order. If a replacement is provided within the warranty period, it does not extend the warranty.

WARRANTY EXCLUSIONS

This warranty does not cover damages caused by misuse, accidents, unauthorized modifications, or any factors unrelated to product manufacturing and design, including but not limited to:

- Loss of parts during use.
- Normal wear and tear of products or parts.
- Incorrect installation (e.g., using the wrong voltage) or improper assembly.
- Overloading the product's bearing capacity.
- Usage in extremely harsh conditions.
- Improper cleaning or lack of maintenance.
- Damage resulting from unintended use of the product.
- Damage resulting from unauthorized modifications or service.
- Indirect losses or damages related to the product.



HOW TO MAKE A WARRANTY CLAIM

If you encounter any defects affecting the product's functionality or if the product fails and cannot be repaired during the warranty period, please reach out to our customer service team via email, Amazon, or our app's messaging service at your earliest convenience. To expedite your claim, kindly include:

- Order number
- Photos and/or videos illustrating the issue
- A detailed description of the problem

VIVOHOME will provide technical support, replacement, refund, or other solutions based on the issue's specifics. If you wish to return the original package for any reason, please contact us for confirmation before initiating the return. You can expect a response within 48 hours.

Thank you for choosing VIVOHOME. We are dedicated to ensuring your satisfaction and the quality of your purchase. If you have any questions or need further assistance, please don't hesitate to reach out to our customer service team.