

Inflatable Spa Assembly Guide

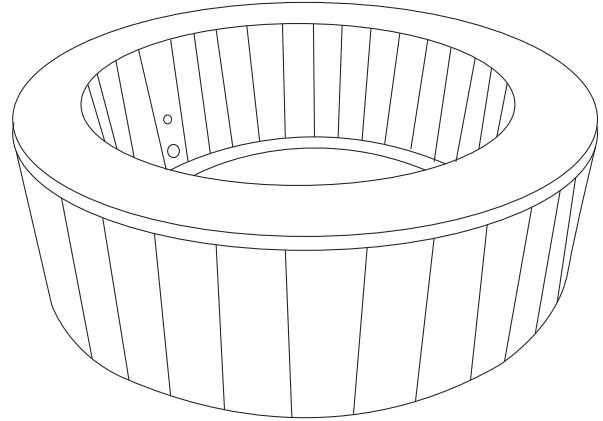
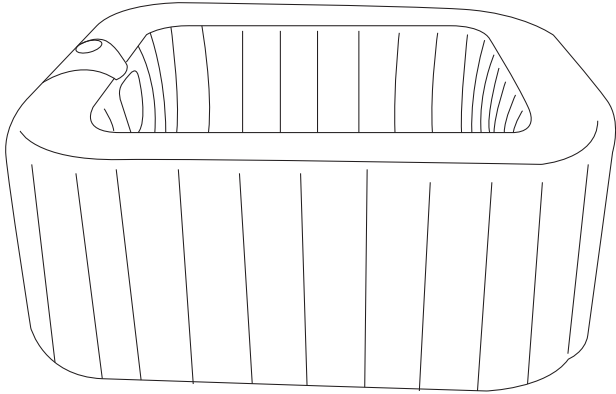

INTRODUCTION

**Thank you for purchasing this Inflatable Hot Tub!
We hope you will enjoy your Spa for many years to come!**

To ensure your personal safety during installation and to get the most out of your investment, please read this entire manual before beginning the installation process. If you feel that this process is too difficult to do on your own, we advise that you seek assistance from a local building or home improvement contractor.

WARNING:

Improper assembly and operation can result in severe personal injury as well as product failure not covered by warranty. Please follow all instructions carefully or contact technical support for assistance.

English CUSTOMER SUPPORT

Dear customer Thank you for your purchase.

This product is a non-permanent outdoor structure designed and manufactured for personal use rather than commercial use.

Please confirm whether the installation is permitted in your states firstly.

1. When you receive the product, please make sure that all the boxes have arrived, and all the parts are intact.

2. Please browse the entire installation manual before assembling, retain this instruction manual for future reference.

3. If any problem occurs unsatisfactorily as follows, please feel free to contact us for help firstly:

- Lack of boxes, or some boxes are not arrived.
- The outer box is damaged.
- The product is damaged / bent / cracked while you open the box.
- The parts / accessories / assembly tools are missing.
- The product is hard to assemble.
- The instructions are not clear, or hoping for assistance with installation.
- The product has functional problems.
- The product did not meet your expectations.
- Other aspects that you are not satisfied with.

If there is any damage, please send us clear photos. We will check and do our best to provide the best solution for you. The missing or damaged parts will be delivered to you within 5 days.

Français SERVICE CLIENT

Cher client merci pour votre achat.

Ce produit est une structure extérieure temporaire, conçue et fabriquée pour un usage personnel et non commercial.

Veuillez d'abord vérifier si son installation est autorisée dans votre pays.

1. À la réception du produit, assurez-vous que tous les cartons sont arrivés et que toutes les pièces sont intactes.

2. Veuillez lire attentivement l'intégralité du manuel d'installation avant le montage et conservez-le pour référence ultérieure.

3. Si vous rencontrez un problème, n'hésitez pas à nous contacter pour obtenir de l'aide :

- Cartons manquants ou incomplets.
- Carton extérieur endommagé.
- Produit endommagé, plié ou fissuré à l'ouverture.
- Pièces, accessoires ou outils de montage manquants.
- Produit difficile à assembler.
- Instructions peu claires ou besoin d'assistance pour l'installation.
- Le produit présente des problèmes de fonctionnement.
- Le produit ne répond pas à vos attentes.

En cas de dommage, veuillez nous envoyer des photos claires. Nous vérifierons la situation et ferons de notre mieux pour vous proposer la meilleure solution. Les pièces manquantes ou endommagées vous seront livrées sous 5 jours.

Deutsch KUNDENDIENST

Sehr geehrter Kunde vielen Dank für Ihren Einkauf.

Dieses Produkt ist eine nicht permanente Außenstruktur, die für den privaten und nicht für den gewerblichen Gebrauch konzipiert und hergestellt wurde. Bitte prüfen Sie zunächst, ob die Installation in Ihrem Bundesstaat zulässig ist.

1. Bitte stellen Sie beim Erhalt des Produkts sicher, dass alle Pakete angekommen sind und alle Teile unbeschädigt sind.

2. Bitte lesen Sie die gesamte Montageanleitung sorgfältig durch, bevor Sie mit dem Aufbau beginnen, und bewahren Sie die Anleitung für zukünftige Verwendung auf.

3. Falls eines der folgenden Probleme auftritt, wenden Sie sich bitte zunächst an uns:

- Fehlende Pakete oder nicht alle Pakete sind angekommen.
- Die Außenverpackung ist beschädigt.
- Das Produkt ist beim Öffnen der Verpackung beschädigt / verbogen / gerissen.
- Teile / Zubehör / Montagewerkzeuge fehlen.
- Das Produkt ist schwer zu montieren.
- Die Anleitung ist unklar oder Sie benötigen Hilfe bei der Montage.
- Das Produkt weist Funktionsprobleme auf.
- Das Produkt entspricht nicht Ihren Erwartungen.
- Andere Punkte, mit denen Sie unzufrieden sind.

Wenn Schäden vorliegen, senden Sie uns bitte klare Fotos. Wir werden den Fall prüfen und unser Bestes tun, um Ihnen die bestmögliche Lösung anzubieten. Fehlende oder beschädigte Teile werden Ihnen innerhalb von 5 Tagen geliefert.

Italiano SERVIZIO CLIENTI

Gentile cliente grazie per il suo acquisto.

Questo prodotto è una struttura temporanea da esterno, progettata e realizzata per un uso personale e non commerciale.

Verifichi innanzitutto se la sua installazione è autorizzata nel suo Paese.

1. Al momento della ricezione del prodotto, si assicuri che tutti i colli siano arrivati e che tutte le parti siano intatte.

2. Legga attentamente l'intero manuale di installazione prima del montaggio e lo conservi per future consultazioni.

3. In caso di problemi, non esiti a contattarci per ricevere assistenza:

- Colli mancanti o incompleti.
- Imballaggio esterno danneggiato.
- Prodotto danneggiato, piegato o incrinato all'apertura.
- Parti, accessori o attrezzi di montaggio mancanti.
- Prodotto difficile da assemblare.
- Istruzioni poco chiare o necessità di assistenza per l'installazione.
- Il prodotto presenta problemi di funzionamento.
- Il prodotto non soddisfa le sue aspettative.
- Qualsiasi altro aspetto che non la soddisfi.

In caso di danni, la preghiamo di inviarci foto nitide. Verificheremo la situazione e faremo del nostro meglio per proporle la soluzione migliore. Le parti mancanti o danneggiate le saranno consegnate entro 5 giorni.

Español SERVICIO AL CLIENTE

Estimado cliente gracias por su compra.

Este producto es una estructura temporal para exteriores, diseñada y fabricada para uso personal y no comercial.

Primero, verifique si su instalación está permitida en su país.

1. Al recibir el producto, asegúrese de que todas las cajas hayan llegado y de que todas las piezas estén intactas.
2. Lea atentamente todo el manual de instalación antes del montaje y consérvelo para futuras consultas.
3. Si tiene algún problema, no dude en contactarnos para obtener ayuda:

- Caja faltante o incompleta.
- Caja exterior dañada.
- Producto dañado, doblado o agrietado al abrirlo.
- Faltan piezas, accesorios o herramientas de montaje.
- Producto difícil de montar.
- Instrucciones poco claras o necesito ayuda con la instalación.
- Producto con problemas de funcionamiento.
- El producto no cumple con sus expectativas.
- Cualquier otro aspecto que no le satisfaga.

En caso de daños, envíenos fotos nítidas. Verificaremos la situación y haremos todo lo posible para ofrecerle la mejor solución. Las piezas faltantes o dañadas se entregarán en un plazo de 5 días.

Polski OBSŁUGA KLIENTA

Drogi Kliencie dziękujemy za zakup.

Produkt ten jest tymczasową konstrukcją zewnętrzną przeznaczoną do użytku prywatnego, a nie komercyjnego. Prosimy najpierw upewnić się, czy instalacja jest dozwolona w Twoim stanie.

1. Po otrzymaniu produktu upewnij się, że wszystkie paczki dotarły i że wszystkie części są nienaruszone.
2. Przed rozpoczęciem montażu zapoznaj się z całą instrukcją obsługi i zachowaj ją do przyszłego użytku.
3. W przypadku wystąpienia poniższych problemów prosimy w pierwszej kolejności o kontakt z nami:

- Brak paczek lub nie wszystkie paczki dotarły.
- Uszkodzone opakowanie zewnętrzne.
- Produkt jest uszkodzony / wygięty / pęknięty po otwarciu pudełka.
- Brak części / akcesoriów / narzędzi montażowych.
- Produkt jest trudny do złożenia.
- Instrukcja jest niejasna lub potrzebujesz pomocy przy montażu.
- Produkt ma problemy z funkcjonowaniem.
- Produkt nie spełnia Twoich oczekiwań.
- Inne aspekty, z których nie jesteś zadowolony.

W przypadku uszkodzeń prosimy o przesłanie wyraźnych zdjęć. Sprawdzimy to i dołożymy wszelkich starań, aby zaproponować najlepsze możliwe rozwiązanie. Brakujące lub uszkodzone części zostaną dostarczone w ciągu 5 dni.

Nederlands KLANTENSERVICE

Beste klant hartelijk dank voor uw aankoop.

Dit product is een niet-permanente buitensstructuur, ontworpen en vervaardigd voor persoonlijk gebruik en niet voor commercieel gebruik. Controleer eerst of installatie in uw staat is toegestaan.

1. Controleer bij ontvangst van het product of alle dozen zijn aangekomen en alle onderdelen intact zijn.
2. Lees de volledige installatiehandleiding door voordat u begint met de montage. Bewaar deze handleiding voor toekomstig gebruik.
3. Neem bij de volgende problemen eerst contact met ons op:

- Ontbrekende dozen, of sommige dozen zijn niet aangekomen.
- De buitenverpakking is beschadigd.
- Het product is beschadigd / verbogen / gebarsten bij het openen van de doos.
- Onderdelen / accessoires / montage materialen ontbreken.
- Het product is moeilijk te monteren.
- De handleiding is onduidelijk of u heeft hulp nodig bij de installatie.
- Het product heeft functionele problemen.
- Het product voldoet niet aan uw verwachtingen.

Als er schade is, stuur ons dan duidelijke foto's. Wij zullen het controleren en ons best doen om u de beste oplossing te bieden. Ontbrekende of beschadigde onderdelen worden binnen 5 dagen naar u verzonden.

IMPORTANT SAFETY INSTRUCTIONS

- WARNING1:** The appliance should be supplied power through a GFCI-equipped outlet with a rated tripping current not exceeding 30 mA.
- WARNING2:** Electric installations should fulfill the requirements of local standards. Grounded appliances must be permanently connected to fixed wiring.
- WARNING3:** If the power supply cord is damaged, it must be replaced by the manufacturer or its service agent or a similarly qualified person in order to avoid a hazard. Replace damaged cord immediately.
- WARNING4:** Parts containing live current, except parts supplied with extra-low safety voltage not exceeding 12 V, must be inaccessible to a person in the bath.
- WARNING5:** To reduce the risk of electric shock, do not use an extension cord to connect unit to electric supply; provide a properly located receptacle.
- WARNING6:** Parts incorporating electrical components, except for remote control devices, must be located or fixed so that they cannot fall into the bath.
- WARNING7:** To avoid electric shock, do not use the spa when it is raining.
- WARNING8:** Never operate the spa if the suction fittings are broken or missing. Never replace a suction fitting with one rated less than the flow rate marked on the original suction fitting.
- WARNING9:** To reduce the risk of injury, do not permit children to use this product unless they are closely supervised at all times.
- WARNING10:** Water attracts children. Always have the spa locked with its cover on after each use.
- WARNING11:** When the jet function is going to be used, make sure the cover of spa is opened first.
- WARNING12:** Do not switch on if there is any possibility that the water in the spa is frozen.
- WARNING13:** Risk of electric shock. Never operate any electrical appliance when in the spa or when your body is wet. Never place any electric appliance, such as a light, telephone, radio, or television, within 5 feet (1.5m) of a spa.
- WARNING14:** Pets should be kept away from spa to avoid damage and injury.
- WARNING15:** Risk of electric shock. Install spa at least 5 feet (1.5m) from all metal surfaces. As an alternative, a Spa may be installed within 5 feet of metal surfaces if each metal surface is permanently connected by a minimum 8-gauge solid copper conductor to the wire connector on the terminal box that is provided for this purpose.
- WARNING16:** Risk of accidental drowning. Extreme caution must be exercised to prevent unauthorized access by children. To avoid accidents, ensure that children cannot use this spa unless they are supervised at all times.
- WARNING17:** During pregnancy, soaking in hot water may cause damage to the unborn fetus. Limit use to 10 minutes at a time while pregnant.
- WARNING18:** The use of alcohol, drugs, or medication before or during the spa use may lead to unconsciousness with the possibility of drowning.
- WARNING19:** Obese persons and persons with a history of heart disease, low or high blood pressure, circulatory system problems, or diabetes should consult a physician before they use a spa.
- WARNING20:** Persons using medication should consult a physician before using a spa since some medication may induce drowsiness while other medication may affect heart rate, blood pressure, and circulation. The water in a spa should never exceed 40°C (104°F). Water temperature between 38°C (100°F) and 40°C (104°F). Are considered safe for a healthy adult. Lower water temperatures are recommended for young children and when spa use exceeds 10 minutes. Since high water temperature has a high potential for causing fatal damage during the early months of pregnancy, pregnant or possibly pregnant women should limit spa water temperature to 38°C (100°F).
- WARNING21:** To reduce the risk of injury, never fill spa with water hotter than 40°C (104°F).
- WARNING22:** The use of alcohol, drugs, or medication can greatly increase the risk of fatal hyperthermia. Hyperthermia occurs when the internal temperature of the body reaches a level several degrees above the normal body temperature of 37°C (98.6°F). The symptoms of hyperthermia include an increase in the internal temperature of the body, dizziness, lethargy, drowsiness, and fainting. The effects of hyperthermia include failure to perceive heat; failure to recognize the need to exit the spa; unawareness of impending hazard; fatal damage in pregnant women; physical inability to exit the spa; and unconsciousness resulting in the danger of drowning.
- WARNING23:** Prolonged immersion in a spa may be injurious to your health.







INFLATABLE SPA ASSEMBLY GUIDE

- CAUTION 1:** To avoid damage to the pump, the spa must never be operated unless the spa is filled with water.
- CAUTION 2:** Immediately leave spa if uncomfortable or sleepy.
- CAUTION 3:** Place only on surface that can withstand the floor loading requirement of your spa.
- CAUTION 4:** The spa should not be setup or left out in temperature lower than 4°C (40°F).
- CAUTION 5:** Never add water to chemicals. Always adding chemicals to water may result in a hazardous chemical spray.
- CAUTION 6:** In order to avoid a hazard due to inadvertent resetting of the thermal cutout, this appliance must not be supplied through an external switching device, such as a timer, or connected to a circuit that is regularly switched on and off by the utility.
- CAUTION 7:** This appliance can be used by children aged from 8 years and above and persons with reduced physical, sensory or mental capabilities or lack of experience and knowledge if they have been given supervision or instruction concerning use of the appliance in a safe way and understand the hazards involved. Children shall not play with the appliance. Cleaning and user maintenance shall not be made by children without supervision.
- CAUTION 8:** The spa should not be setup or left out in temperatures lower than 4°C (40°F).

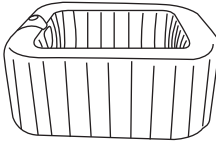
APPLICABLE MODELS

MODEL	4-6 places	4-6 Places
Type	square	round
Number Of Persons	4~6	4~6
Water Capacity	910 Liters	1000 Liters
Voltage/ Frequency	AC 220-240 / 50Hz	AC 220-240 / 50Hz
Rated Power	1800w	1800w
External Dimensions	73'' x73'' /185x185cm	82'' x82'' /208x208cm
Internal Dimensions	57'' x57'' /145x145cm	66'' x66'' /168x168cm
Height	25.6'' /65 cm	25.6'' /65 cm
Filterpump (AC 12V/50Hz)	1400 l/h	1400 l/h
Air Blower (AC 220-240V/50Hz)	600 w	600 w
Heater (AC 220-240V/50Hz)	1800w	1800w
PLUG	RCD	
Temperature Range	68-104 ℉/20-40 C	68-104 ℉/20-40 C
Temperature Rise (per hour)	1.8-2.7 F/1-1.5C	1.8-2.7 F/1-1.5C
Number of Air Jets	130	130
Weight Of Spa filled With Water (Without Persons)	2063 lb/936 kg	2259 lb/1025 kg

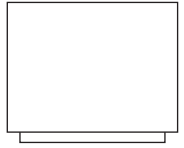
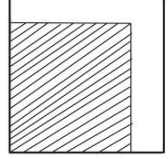
INFLATABLE SPA ASSEMBLY GUIDE

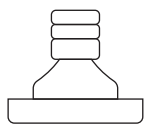
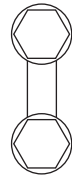
Parts List				
A	B	C	D	E
				
Spa pool	Clip-on Top Cover	Inflation hose	Filter cartridge	Filter cartridge cover
F	G	H	I	J
				
Ground mat	Repair kit	Child Safty Key	Drain connection	Wrench

WARNING:

Site Requirements:

- The floor has to be capable of supporting the expected load.
- An adequate drainage system has to be provided to deal with overflow water.

IMPORTANT:

Because of the combined weight of the spa, water, and users, it is extremely important that the base where the spa is installed is smooth, flat, level and capable of uniformly supporting this weight for the entire time the spa is installed. If the spa is placed on a surface which does not meet these requirements, any damage caused by improper support will void the warranty. It is the responsibility of the spa owner to maintain the integrity of the site at all times.

Indoor Installation

- There are a few special requirements if you plan to install the spa indoors.
 1. The floor must be able to withstand the weight of the spa at full capacity. The floor should be a non-slip, level surface.
 2. Proper drainage is essential for indoor spa installation. When building a new room for the spa it is recommended that a floor drain be installed.
 3. Humidity is a natural side effect of spa installation. Determine the effects of airborne moisture on exposed wood, paper, etc. in the proposed location.
- To minimize these effects it is best to provide plenty of ventilation to the selected area. An architect can help determine if more ventilation is needed.

NOTE: Do not install the spa on carpet or other material that can be damaged by moisture.

Outdoor Installation

- No matter where you install the spa, it is important you have a solid support foundation. If you are installing the spa outdoors, ensure there are no sharp objects that could damage it and that the location is level so the spa is stable and secure.
- During filling, emptying or when in use, water may spill out of the spa. The spa should be installed near a ground drain.
- Do not leave the spa's surface exposed to direct sunlight for long periods of time.

ASSEMBLY

Step1: Unfold the spa from the packaging. Spread the spa and cover. Make sure both are right side up (Fig. 1).

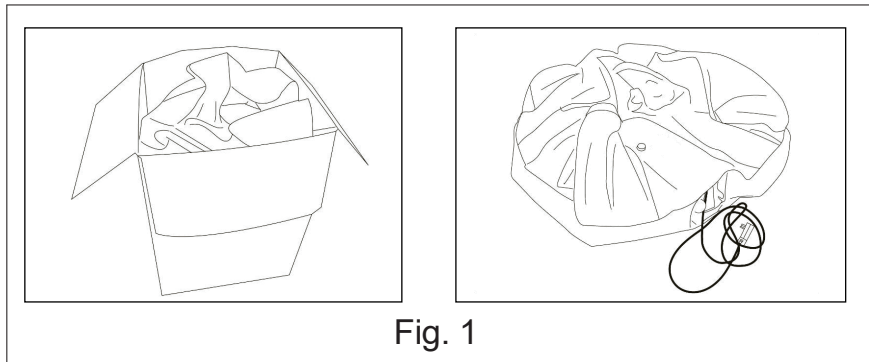

Step2: Fully unfold the ground mat and spread it out on the ground. (Fig. 2).

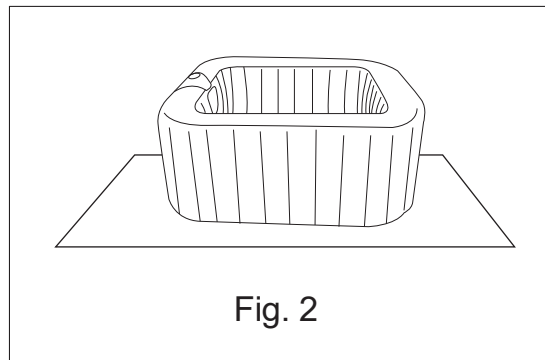

Step3: Open the air outlet on the spa. Screw one end of the inflation hose into it (Fig. 3).

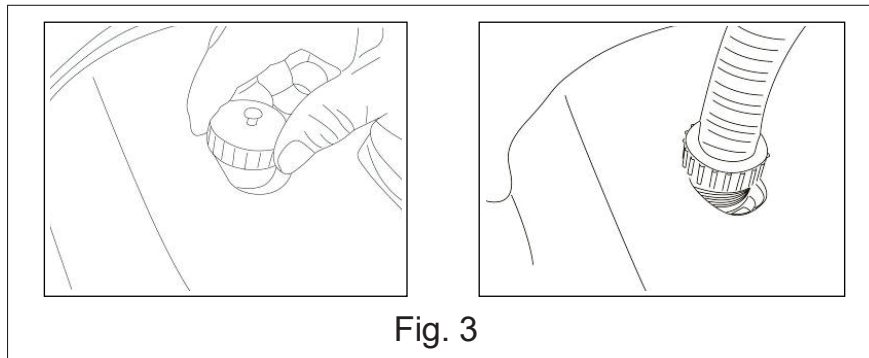

Step4: Open the air valve on the spa. Connect the other end of inflation hose into the valve (Fig. 4).

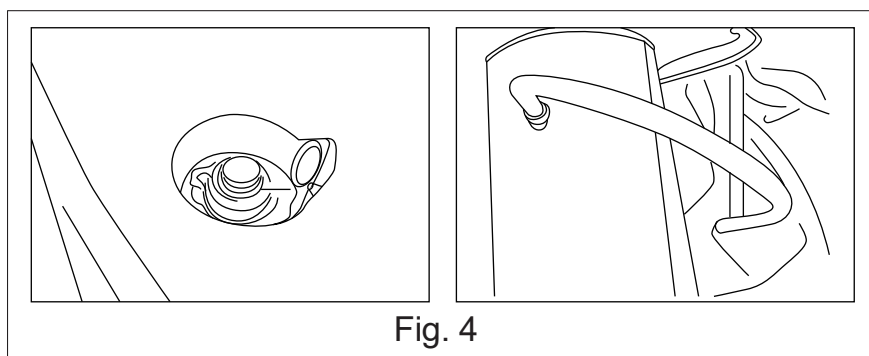

INFLATABLE SPA ASSEMBLY GUIDE

- Step5:** Inflate the spa tub by pressing the BUBBLE button. When the spa is properly inflated, press the BUBBLE button to shut off the bubbles.
Attention 1: Do not over inflate.
Attention 2: To inflate spa while filled with water, you must put on the Jets for 2-3 minutes by pressing the BUBBLE button first, and then operate according to step 2-6.

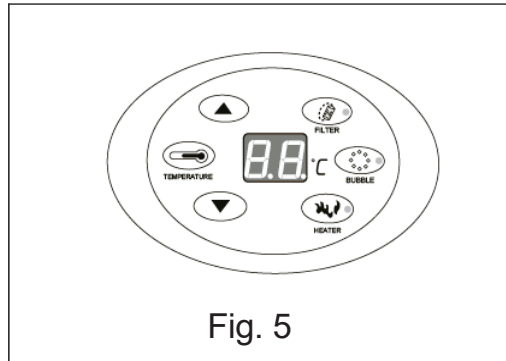

Fig. 5

- Step6:** Remove the inflation hose and screw the valve tight.
Step7: Remove the inflation hose from the air outlet and screw the valve cap tight.

- Step8:** Screw the filter cartridge onto the two water inlets (there are two inlets on the spa wall) on the spa wall by turning it clockwise (Fig. 8).

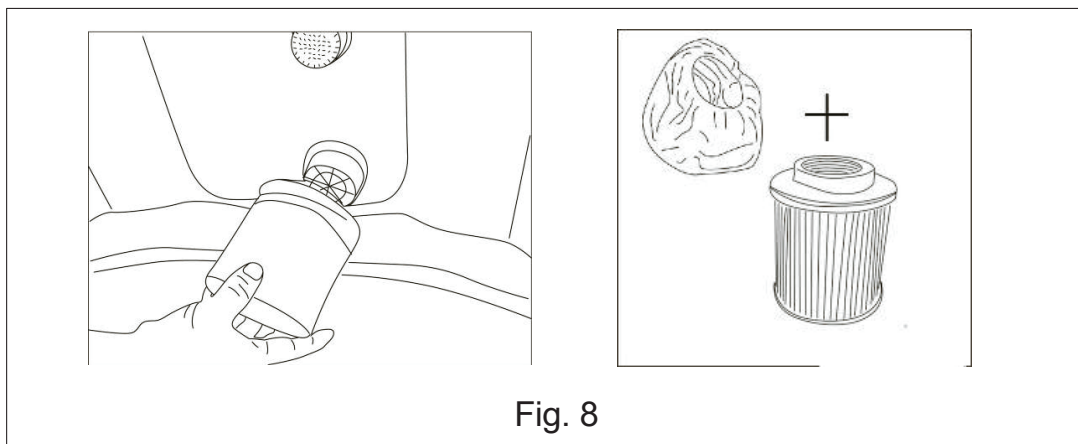

Fig. 8

- Step9:** Fill the spa using a garden hose to fill to the water level printed on the spa wall (Fig. 9).
Step10: Place the cover onto the spa, double lock with safety locking keys (Fig. 10).

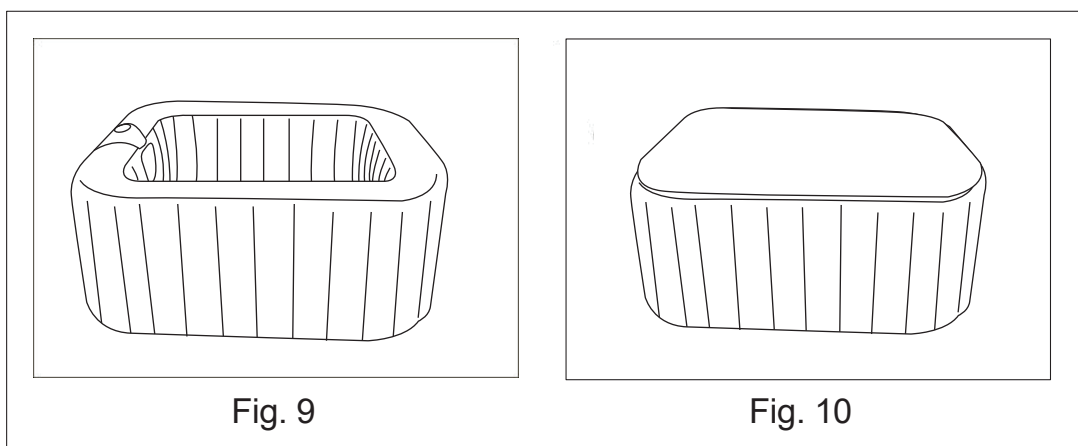

Fig. 9

Fig. 10

OPERATION

**Before using, ensure the water in the spa matches the water line printed on the spa wall.
Never dry-run the power pack as such type of operation will void the warranty.**

Control Panel

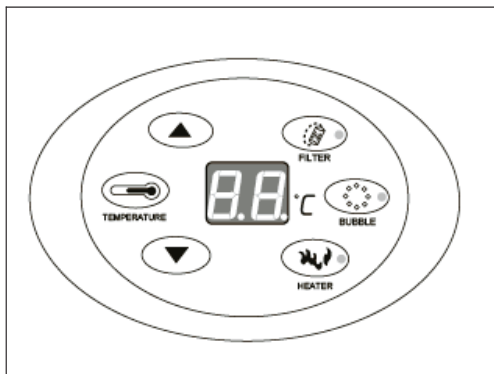

FILTER Key - On/Off key for the filtration system. Press this key, and the filter pump will start working and the red indicator lamp will be on. Press again and the pump will stop working and the lamp will be off.

When the FILTER PUMP has worked for 168 hours, the letters 'FC' will appear on the display screen, accompanied by a warning tone. At that time, the indicator lamp for the FILTER key will be on, but the filter pump will not be in operation. The indicator lamp for the HEATER key will be off, and the heating system will not work. Only by pressing the FILTER key again can its indicator lamp on the control panel (Left) be turned off. At that time, the letters 'FC' on the display screen will disappear and so will the warning tone. Actual water temperature will be displayed. All keys return to normal working status.

**'FC' and the warning tone are to remind the user to clean or replace the filter element.
Press the "FILTER" key after replacing a new filter element to restart the system.**

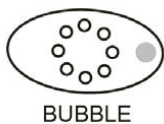

BUBBLE Key Press this key and the air pump will start working and the red indicator lamp will be on. The Bubble system will stop automatically after 20 minutes of continuous operation. To restart bubble, wait 10 minutes and then press the BUBBLE key again. Do not restart bubble before waiting 10 minutes. When the bubble have been on for 20 minutes and have stopped, the function cannot be started again within 10 minutes.



HEATER Key - On/Off key for the heating system. Press this key and the heating system will start working and the red indicator lamp will be on. Press again and the heating system will stop and the indicator will turn off. When the heating system is turned on, the red indicator lamp of the FILTER key will also be on and the filter pump will start working as well. This is a normal occurrence required by the design. When the preset temperature has been reached, the heating system will stop working, but the heating indicator light will not turn off. The filter pump will continue to operate, with the indicator light on. When the water falls 2°C below the preset temperature, the heating system will begin to automatically heat the water back up to selected temperature.



TEMPERATURE Key – Key for setting temperature. Press this key and the numbers on the display screen will start flashing, then the keys for increasing or decreasing temperature can be pressed to set the temperature. When desired settings are entered, press the TEMPERATURE Key again to confirm. Default temperature is 104°F, and temperature can be set in the range of 68-108°F.



UP Key - Increases spa temperature.



DOWN Key - Decreases spa temperature.

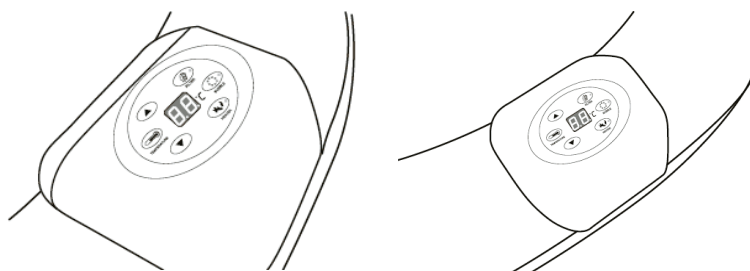

- Base of the controller is made of environmentally-friendly polyurethane material that is soft and comfortable.
- Surface of the base can be washed.
- The controller is chrome-plated, which meets ROHS standards.
- Surface films are glued to the controller with marine glue.

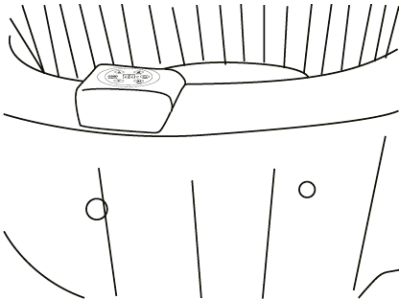

1. Filling Hot Tub with Water

- Water should be filled to a position between minimum and maximum water line. If lower, heating may not be fully effective. If higher, water may spill over the basin during use.

2. Water Treatment

- Water in the basin should be filtered at fixed times regularly. It is not suggested to filter the water at all times.

- Water in the basin should be treated with chemical agents periodically. However, chemical agents with calcium ions must not be used. If chemical agents with calcium ions are used for water treatment, it is very likely that calcium scale will form on the walls of water basin and inner heating pipes. Water scales will directly damage the inner electrical components inside the control cabinet and further affect the service life of control cabinet.
- If the filtration system has worked for 168 hours, the system will emit a warning tone to remind the user to clean or replace the filter element.

3. Hot Tub Care

- Drain off the water inside the water basin completely and wipe off droplets of water on the walls. After that, lay aside the spa for 24 hours, exhaust the air and fold. If it is Winter, please fold the spa indoors. The outside temperature in Winter is very low and materials may become hard, in that case, folding the materials may result in breakage. Put the spa inside the packing case after folding it well and then put the case in a shaded place to avoid direct sunlight.

MAINTENANCE

1. Maintaining Spa Water

- Clean your filter cartridge at least once every time it has worked continuously for 72- 120 hours. The filter cartridge should be replaced at least once a month depending on use.
- Change water every few days or use appropriate pool chemicals. All spas require the use of pool chemicals. Please consult your local pool supply retailer for more information about chemical maintenance. Pay close attention to the chemical manufacturer's instructions. Spa damage resulting from misuse of chemicals and mismanagement of spa water is not covered by the warranty.
 - Water balance; we recommend you maintain the spa water pH between 7.2 and 7.8, total alkalinity between 80 and 120ppm, and free chlorine between 3 to 5ppm.
 - Purchase a test kit to test your water chemistry before each use of the spa, no less than once per week. Low pH will damage to the spa and pump. Damage resulting from chemical imbalance is not covered by the warranty.
 - Water sanitation is the responsibility of the spa owner, achieved through the regular and periodic (daily, if necessary) addition of an approved sanitizer. The sanitizer will chemically control bacteria and viruses present in the fill water or introduced during use of the spa.

2. Cleaning the Filter Cartridge

Make sure to unplug the power pack from the electrical receptacle before the following actions.

- Unscrew the filter cartridge by turning counterclockwise (Fig 1).
- Remove the filter cartridge cover (Fig. 2).

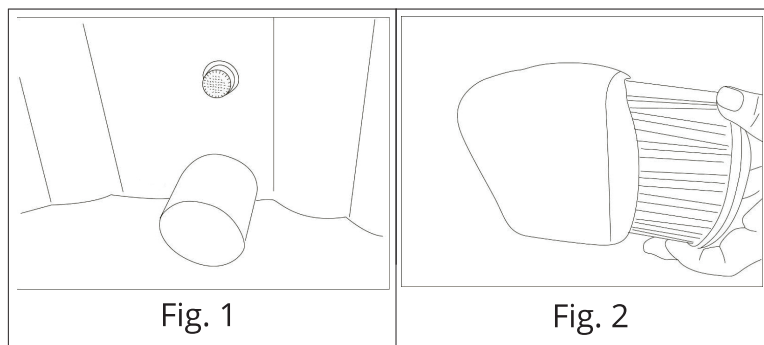

INFLATABLE SPA ASSEMBLY GUIDE

- The filter cartridge can be rinsed off with a garden hose and reused. However, if the filter cartridge remains soiled and discolored the filter cartridge should be replaced (Fig.3).
- Re-apply filter cartridge cover and attach the filter cartridge to the water inlet by turning clockwise (Fig.4).

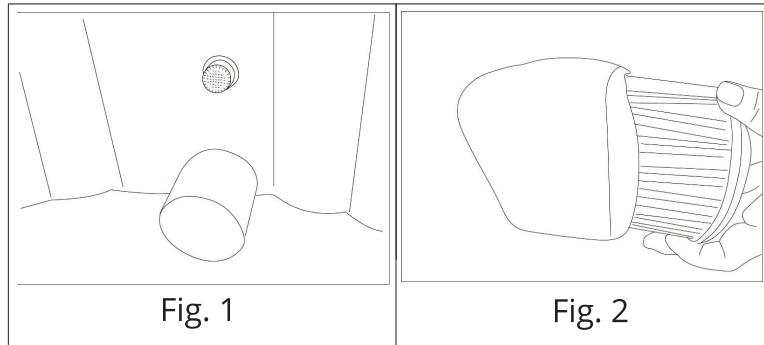

3. Drainage

- Make sure to unplug the power pack from the electrical receptacle.
- Put the plastic plug into the outlet in the inner wall of the spa.
- Open the outlet in the outer wall of the spa. Screw one end of inflation hose into it.
- Pull the plastic plug off from the outlet in the inner wall of the spa, then the water will flow out (Fig. 5).
- When there is no water in the spa, you must put on the jet function for at least 5 minutes by pressing the BUBBLE button to drain the water in the air pipeline.
- When drainage is finished, remove the inflation hose and screw the nut tight.

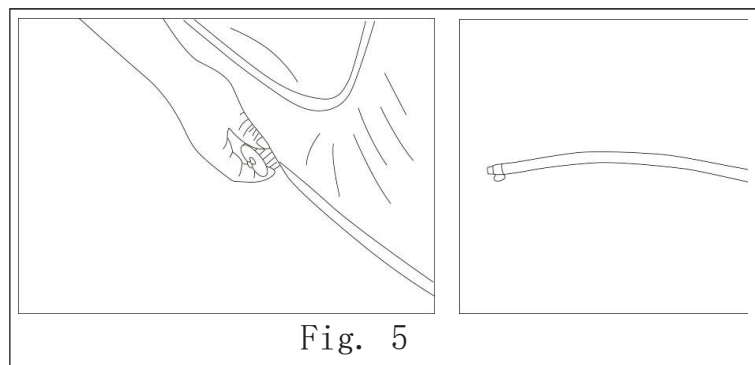

4. Cleaning the Spa

- Detergent residues and dissolved solids from bathing suits and chemicals will gradually accumulate in the spa's water.
- To clean the spa, use soap and water then rinse.

Note: do not use hard brushes or abrasive cleaners.

REPAIR AND STORAGE

1. Spa Repair

- If the spa is torn or punctured, use the provided repair patch.
 - Dry the area to be repaired.
 - Apply the glue in the accessory bag to the repair patch and then attach it onto the damaged area.
 - Smooth the surface to remove any air bubbles. A secure unnoticeable repair can usually be made.

2. Spa Storage

- Make sure all water is drained from the spa and control box. This is essential to extend the life of the spa. We recommend the use of a wet/dry vacuum to blow out or suck up water from the spa pipes and pump lines.
- Remove the filter cartridge.
- It is recommended you store the spa in its original package in a warm dry place.

Note: Plastic becomes brittle and susceptible to breakage when exposed to subzero temperatures. Freezing can severely damage the spa. Improper winterization of your spa may void your warranty.

TROUBLESHOOTING

Here are some helpful tips to help you to diagnose and rectify some common sources of trouble.

Problems	Probable Causes	Solutions
Jet system does not operate	---Air pump is too hot ---Something is wrong with the power box	---Unplug the air pump. After the air pump has cooled, insert the plug and press the Jet button to activate. --- Call for service if it does not reset.
Heating system does not operate	---Temperature set too low ---Dirty filter cartridge ---Improper water levels ---Heating element failed	---Set to a higher temperature (20-42°C). ---Clean/replace the filter cartridge in time. ---Add water to specified levels. --- Call for service.
Filtering system does not operate	---Dirty filter cartridge ---Something is wrong with the power box ---Voltage too low or incorrect frequency	---Clean/replace the filter cartridge in time. ---Call for service if it does not reset. ---Ask professional electrician to check whether the household input voltage or frequency is normal
Spa leakage	---Spa is torn or punctured	---Use provided repair patch
Water not clean	---Insufficient filtering time ---Dirty filter cartridge ---Improper water maintenance	---Increase filtration time. ---Clean/replace the filter cartridge. ---Refer to the chemical manufacturer's instructions.

ELECTRICAL PROTECTION LEVEL

Warning: Protection levels vary based on the Zone spa is placed in. See the below scheme:

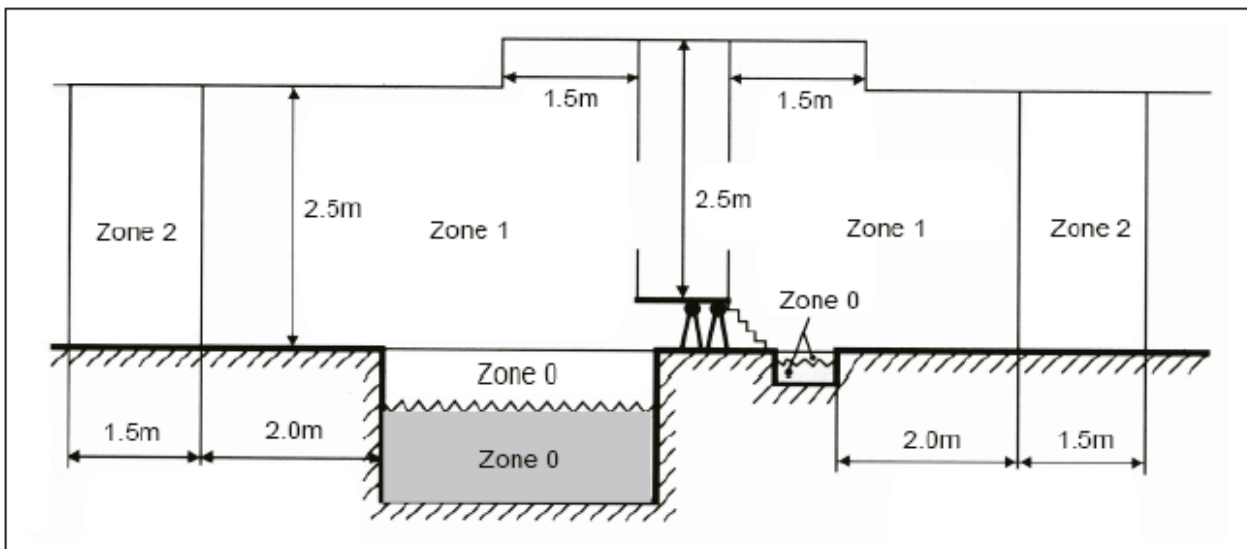

Above figure: Zone dimensions of swimming pools and paddling pools

Note: The measured zone dimensions are not limited by walls and fixed partitions.

- A permanent grounded bond consisting of a minimum 8-gauge solid copper conductive wire is required between spa control panel grounding terminal and any metal surface located in Zone 1.
- No metal surfaces or outside electrical devices may be present within Zone 0 for any reason.
- All bonded connections must be fully-conductive and grounded.
- Electrical equipment shall have at least the following degrees of protection:
 - Junction boxes shall not be installed in Zones 0 and 1.
 - In Zones 0 and 1, no switches, lights or any other electrical components shall be present.
 - The transformer must be located outside Zone 1.

TROUBLESHOOTING

We decline liability for any damage or accident derived from any use of this product which is not in conformity with the instructions contained in this booklet. Please consult a licensed electrician for further electrical installation guidelines, or in placement scenarios not specifically mentioned in this manual.

- A permanent grounded bond consisting of a minimum 8-gauge solid copper conductive wire is required between spa control panel grounding terminal and any metal surface located in Zone 1.
- No metal surfaces or outside electrical devices may be present within Zone 0 for any reason.
- All bonded connections must be fully-conductive and grounded.
- Electrical equipment shall have at least the following degrees of protection:

Problems	Cause	Solution
The display does not respond/does not switch on	The safety switch is deactivated	Perform a reset (in accordance with Installation)
	The water temperature is above 116.6°F(47°C)	Wait until the water temperature has dropped below 104°F(40°C) and press the "manual reset button"
Heater stop working	Temperature sets too low	Set a higher temperature 68°F- 104°F(20-40°C)
	The water temperature is still within the tolerance range of the temperature sensor <+/- 3.6 °F (2°C)>	Once the set water temperature reached, the heater will stop working until the water temperature drops 3.6(2 °C) below the set temperature. In this case just wait for a few minutes and the heater will start working automatically.
	Spa is not covered	Attach the cover
	The filter cartridge is dirty	Replace the filter cartridge
	Water level is too low	Top up the water between min and max line
	Problem with the filter/air and massage jets/heater unit	Disconnect the power supply, wait 10 minutes before switching the power back on
	Dirt deposits inside the motor block (Heating pipe with incrustant、 Filter pump blocked、 Plugged filter cartridges)	Remove the filter cartridge and flush the motor block using a water hose by placing the water hose at the water outlet and collecting particles of dirt at the filter connection using a cloth bag
Filter system stop working	The filter cartridge is dirty	Replace the filter cartridge
	Water level is too low	Top up the water between min and max line
	Problem with the filter/air and massage jets/heater unit	Disconnect the power supply, wait 10 minutes before switching the power back on
Filter pump running too loud	The filter cartridge is dirty	Replace the filter cartridge
	Water level too low	Top up the water between min and max line
	Dirty cover (on filter cartridge)	Clean the cover
Problem with the filter/air and massage jets/ heater unit	Power voltage too low or incorrect frequency	Contact a qualified electrician
	Fault in the filter/air and massage jets/heater unit	Disconnect the power supply, wait 10 minutes before switching the power back on
The tub has a strange shape	Additional air pressure due to strong sunlight	Check the air pressure (using barometer, the pointer points to the green range) and deflate to the normal shape

INFLATABLE SPA ASSEMBLY GUIDE

Problems	Cause	Solution
The SPA is losing air pressure	Air valve cap is too loose	Using soapy water, cover the air-valve to check if air is leaking, if so, use the provided wrench to fasten the Air valve following these steps: 1. Deflate the spa. 2. With one hand, hold the backside of the Air valve from the inner side of the spa wall and turn the wrench clockwise.
	Tear (seam) or spot damage	Perform a test to locate the affected area
	Ambient temperature drops drastically.	It is normal that the air sink in low temperature environment. Fill more air into the spa, refer to Inflation on page 12.
The SPA is losing water	The sealing plug of the water drain at the bottom of the SPA is loose	Press the drainage bung tightly.
	Spa is torn or punctured	Use provided repair patch. (Put liquid soap and water in a squirt bottle and spray on seams. If there is a leak it will bubble. After you find the leak, clean and dry the leaking area, then apply the repair patch that comes with your spa.)
The water is not clean	Insufficient filtering time	Increase the filtering time
	The filter cartridge is dirty	Replace the filter cartridge
	Poor or insufficient water treatment	Read the instructions of the chemicals manufacturer

CORRECT DISPOSAL OF THIS PRODUCT



This marking indicates that this product should not be disposed with other household wastes throughout the EU. To prevent possible harm to the environment or human health from uncontrolled waste disposal, recycle it responsibly to promote the sustainable reuse of material resources. To return your used device, please use the return and collection systems or contact the retailer where the product was purchased. They can take this product for environmental safe recycling.

(Read this entire manual before operation)

English

AFTER-SALES

AFTER-SALE SERVICE

- If you have any suggestions or encounter quality issues with our products, please contact us first.
- Our after-sales team will respond within 24 hours, and we will do our best to provide a solution until you are satisfied.

GUARANTEED CUSTOMER SERVICE

- Your shopping experience is very important to us!
- If you feel unsatisfied or have any questions, **just contact us!**
- If you want to share how wonderful our smart product makes your home, **just contact us** and share your pictures!
- For further information, **just contact us!**

Français

APRÈS-VENTE

SERVICE APRÈS-VENTE

- Pour toute suggestion ou tout problème de qualité concernant nos produits, veuillez nous contacter.
- Notre équipe après-vente vous répondra sous 24 heures et s'efforcera de trouver une solution satisfaisante.

SERVICE CLIENT GARANTI

- Votre expérience d'achat est notre priorité !
- En cas de toute insatisfaction ou question, **n'hésitez pas à nous contacter.**
- Si notre produit intelligent a eu un impact positif sur votre intérieur, nous serions ravis que vous partagiez vos photos avec nous !
- Pour plus d'informations, **contactez-nous sans hésiter !**

Deutsch

AFTER-SALES

KUNDENSERVICE NACH DEM

- Wenn Sie Vorschläge haben oder Qualitätsprobleme mit unseren Produkten feststellen, kontaktieren Sie uns bitte zunächst.
- Unser After-Sales-Team wird innerhalb von 24 Stunden antworten und wir werden unser Bestes tun, um eine Lösung zu finden, die Sie zufriedenstellt.

GARANTIERTER KUNDENSERVICE

- Ihre Einkaufserfahrung ist uns sehr wichtig!
- Wenn Sie unzufrieden sind oder Fragen haben, **kontaktieren Sie uns einfach!**
- Wenn Sie teilen möchten, wie unser intelligentes Produkt Ihr Zuhause bereichert, kontaktieren Sie uns und teilen Sie Ihre Bilder!
- Für weitere Informationen, **kontaktieren Sie uns einfach!**

Italiano

POST-VENDITA

ASSISTENZA POST-VENDITA

- Per qualsiasi suggerimento o problema di qualità relativo ai nostri prodotti, non esiti a contattarci.
- Il nostro team di assistenza post-vendita risponderà entro 24 ore e cercherà di trovare una soluzione soddisfacente.

ASSISTENZA CLIENTI GARANTITA

- La sua esperienza di acquisto è la nostra priorità!
- In caso di insoddisfazione o domanda, **non esiti a contattarci.**
- Se il nostro prodotto intelligente ha avuto un impatto positivo sul suo ambiente, saremo felici di ricevere le sue foto!
- Per ulteriori informazioni, **non esiti a contattarci !**

SERVICIO POSTVENTA

- Para cualquier sugerencia o problema de calidad relacionado con nuestros productos, no dude en ponerse en contacto con nosotros.
- Nuestro equipo de postventa le responderá en un plazo de 24 horas y se esforzará por encontrar una solución satisfactoria.

SERVICIO AL CLIENTE GARANTIZADO

- ¡Su experiencia de compra es nuestra prioridad!
- Si tiene alguna insatisfacción o pregunta, **no dude en ponerse en contacto con nosotros.**
- Si nuestro producto inteligente ha tenido un impacto positivo en su hogar, ¡nos encantaría que compartiera sus fotos con nosotros!
- Para obtener más información, **no dude en contactarnos !**

SERWIS POSPRZEDAŻOWY

- Jeśli masz jakiegokolwiek sugestie lub napotykasz problemy z jakością naszych produktów, prosimy o kontakt.
- Nasz zespół serwisu posprzedażowego odpowie w ciągu 24 godzin i dołoży wszelkich starań, aby znaleźć rozwiązanie, które Cię usatysfakcjonuje.

GWARANTOWANA OBSŁUGA KLIENTA

- woje doświadczenie zakupowe jest dla nas bardzo ważne!
- Jeśli czujesz się niezadowolony lub masz jakiegokolwiek pytania, **po prostu skontaktuj się z nami!**
- Jeśli chcesz podzielić się, jak nasze inteligentne produkty zmieniają Twoje wnętrze, skontaktuj się z nami i podziel się swoimi zdjęciami!
- Po więcej informacji, **po prostu skontaktuj się z nami !**

NA VERKOOP SERVICE

- Als u suggesties heeft of kwaliteitsproblemen ondervindt met onze producten, neem dan eerst contact met ons op.
- Ons aftersales-team zal binnen 24 uur reageren en we zullen ons best doen om een oplossing te bieden die u tevreden

GEGARANDEERDE KLANTENSERVICE

- Uw winkelervaring is voor ons erg belangrijk!
- Als u ontevreden bent of vragen heeft, **neem dan gerust contact met ons op.**
- Als u wilt delen hoe ons slimme product uw huis heeft verbeterd, neem dan contact met ons op en deel uw foto's!
- Voor meer informatie, **neem gerust contact met ons op!**