

Assembly Instructions



Console Table

Model No.
HOGA-RY0358

Contact Us

We're here to help you.



Your satisfaction is our top priority. If you encounter any issues with this product, such as missing or damaged parts, we're here to help. Please retain the original packaging and take photos of the packaging and the product, then contact us as soon as possible.

Warm Tips

1. Carefully read these instructions and keep them for future reference.
2. Check the parts list and confirm everything's there before starting assembly.
3. When assembling, put all parts on a soft, smooth surface like a carpet to avoid scratches.
4. Don't fully tighten screws until all parts are confirmed in place to avoid misalignment.

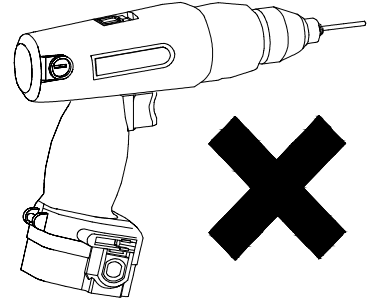
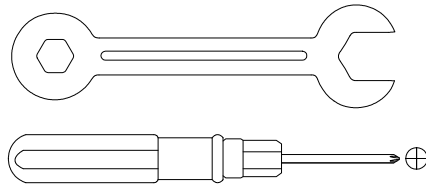
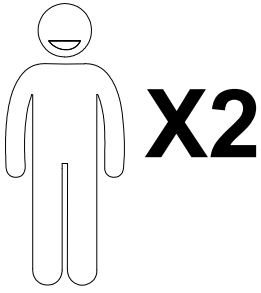

We recommend using hand tools for assembly.

If an electric screwdriver is used, reduce power and torque to avoid damage to the product.

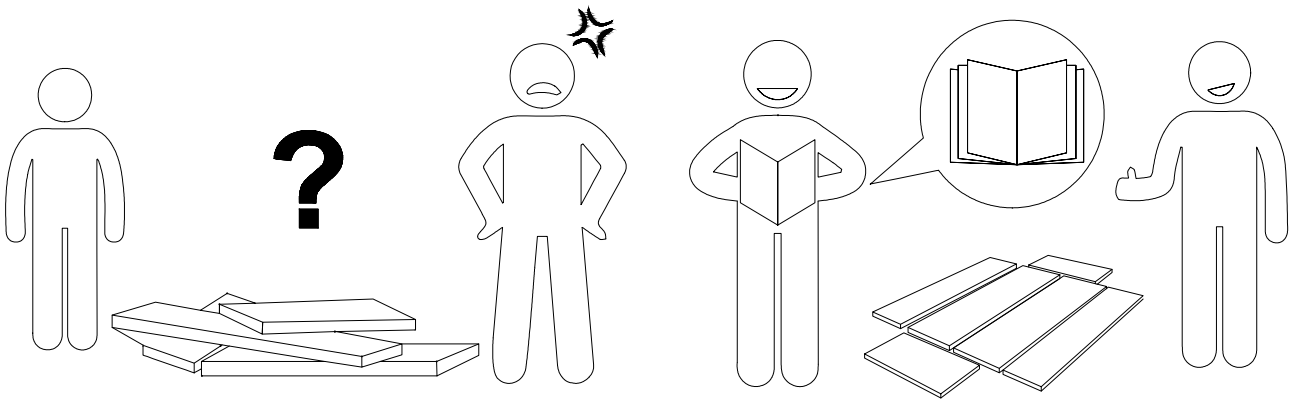

Install the Anti-Tip Straps

Using the anti-tip straps can reduce the risk of tipping over, but can not eliminate it.

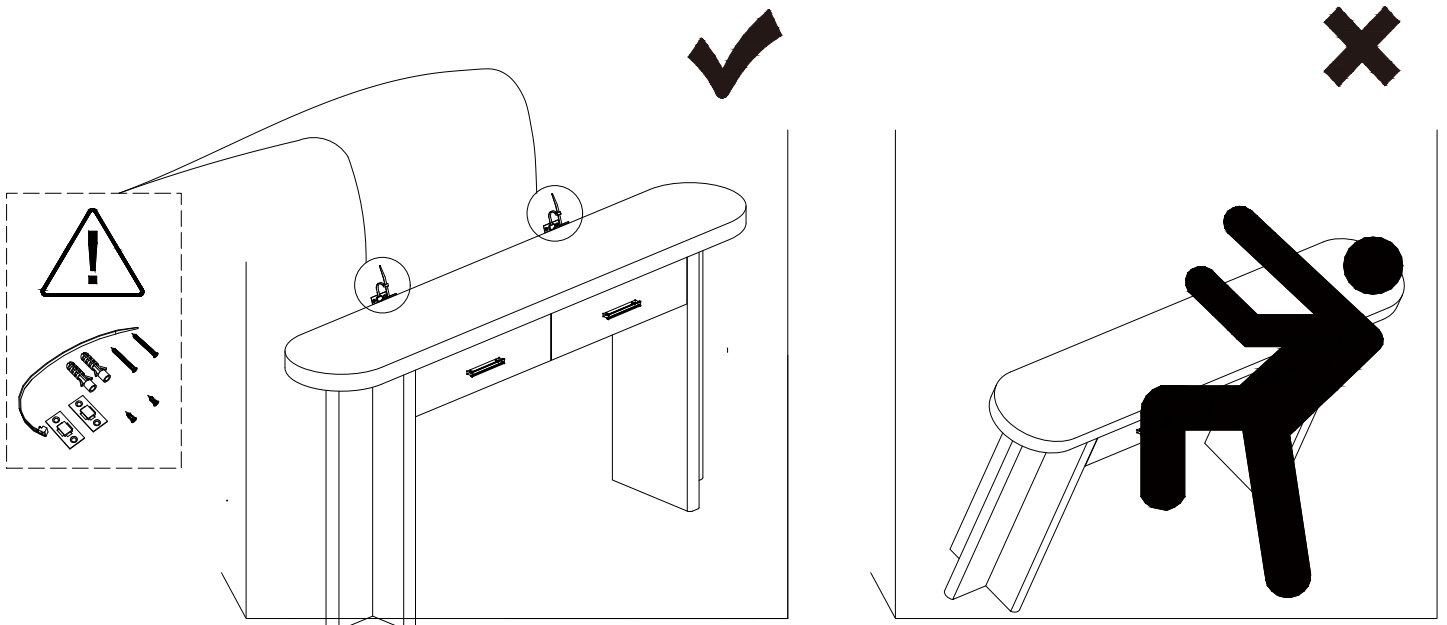

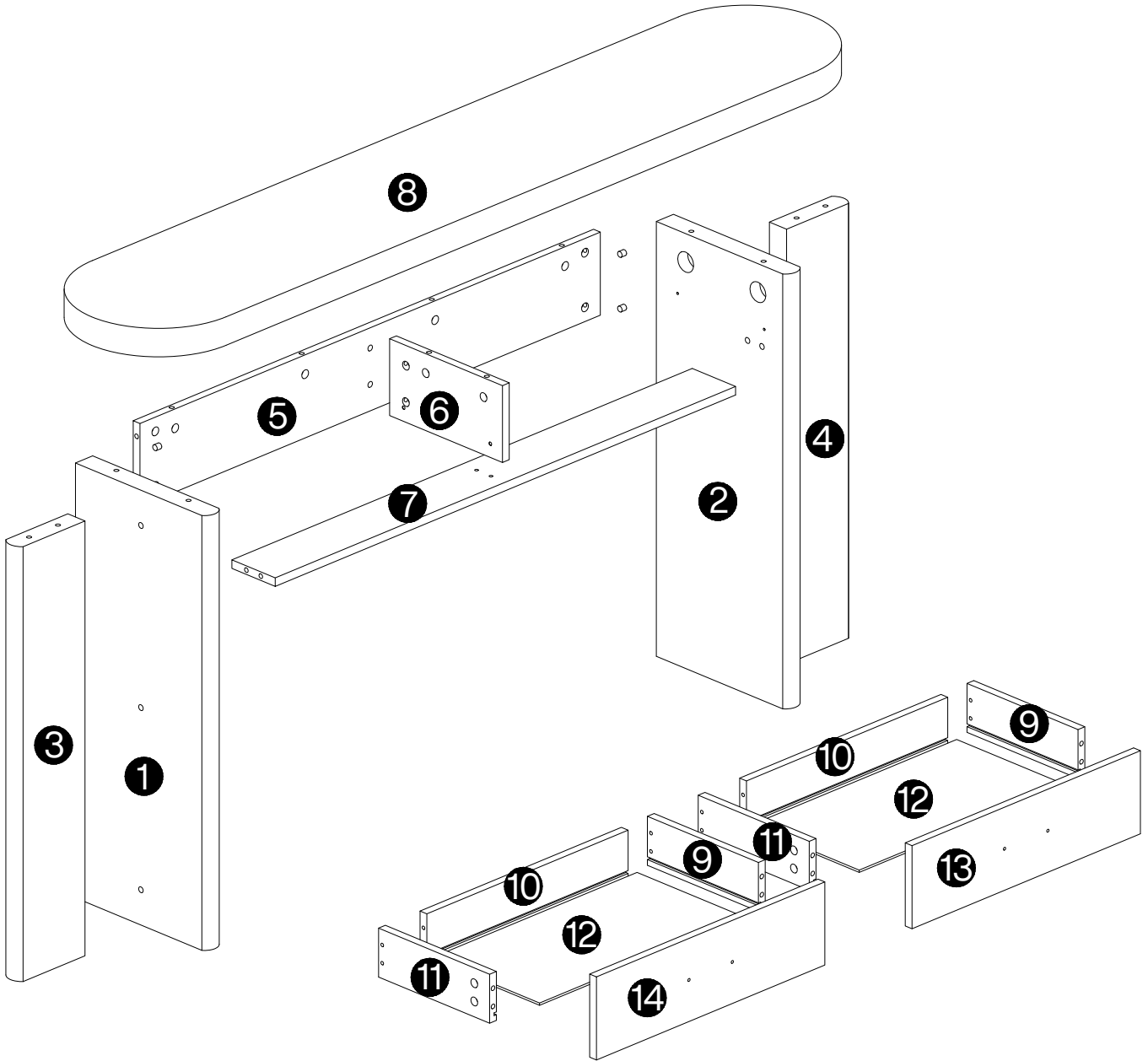

⚠ Caution

Make sure all parts are included. Most board parts are labeled or stamped on the raw edge. Contact us for a free replacement if you encounter any damaged or missing parts.

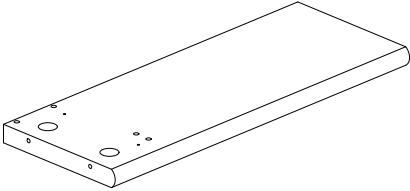
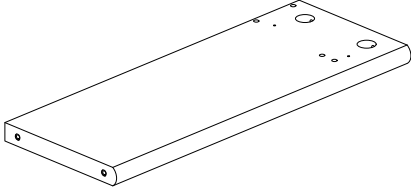
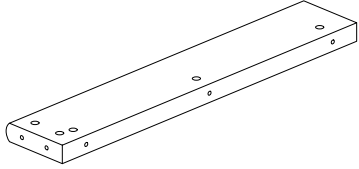
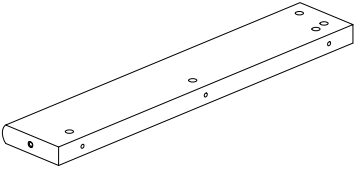
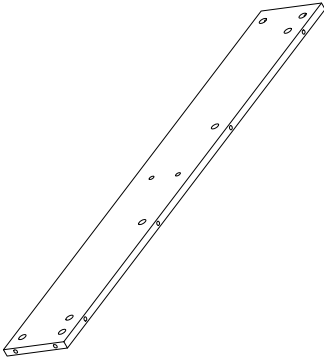
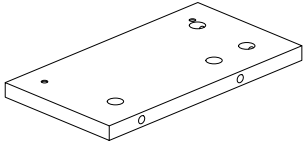
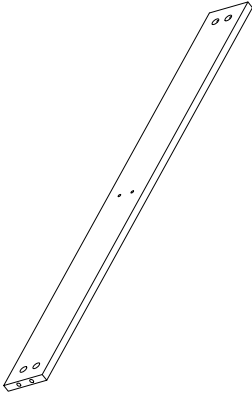
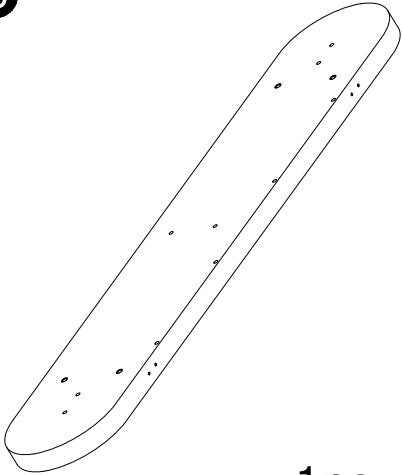
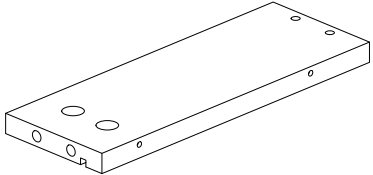

Parts List



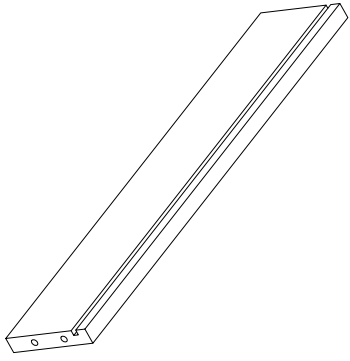
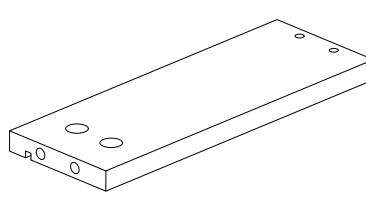
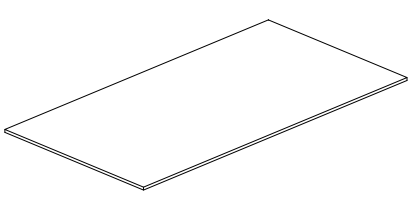
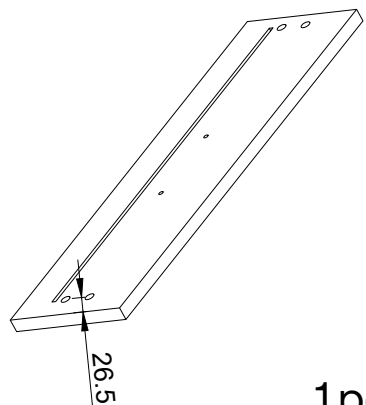
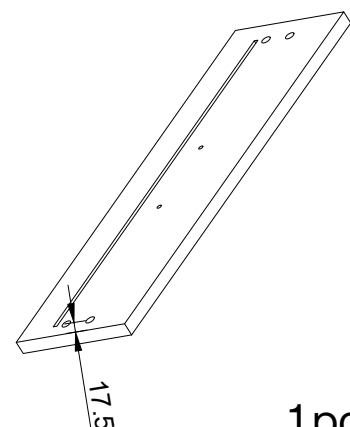
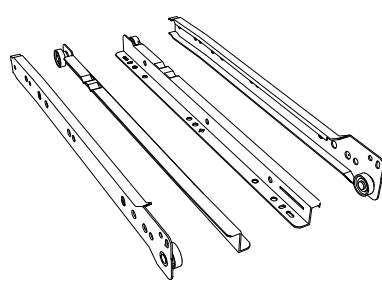

<p>1</p>  <p>1pc</p>	<p>2</p>  <p>1pc</p>	<p>3</p>  <p>1pc</p>
<p>4</p>  <p>1pc</p>	<p>5</p>  <p>1pc</p>	<p>6</p>  <p>1pc</p>
<p>7</p>  <p>1pc</p>	<p>8</p>  <p>1pc</p>	<p>9</p>  <p>2 pcs</p>

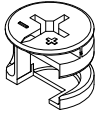
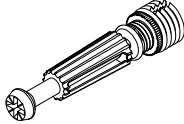
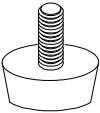

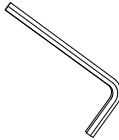
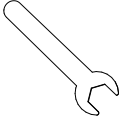
Parts List

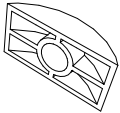
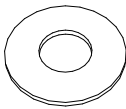
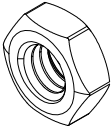
<p>10</p>  <p>2 pcs</p>	<p>11</p>  <p>2 pcs</p>	<p>12</p>  <p>2 pcs</p>
<p>13</p>  <p>1pc</p>	<p>14</p>  <p>1pc</p>	<p>15</p>  <p>2 sets</p>

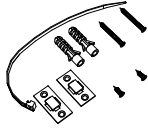
Hardware List

A	B	C	D	E	F
					
Ø15x12mm	M6x40mm	M6x15mm	M4	M3	
34 pcs	34 pcs	6 pcs	1 pc	1 pc	1 pc

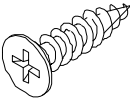
G	H	I	J	K	L
					
		M8x5mm	M8x70mm		M5x38mm
4 pcs	4 pcs	4 pcs	4 pcs	2 pcs	10 pcs

M	N	O			
					
M3.5x14mm	Ø4x20mm	96			
16 pcs	4 pcs	2 pcs			

Installation of Cams and Pins

Step 1-2: Align the plastic part with the mounting hole and press it in. If you can't press it in, loosen the screw counter clockwise or completely remove the screw from the plastic part and try again.
Step 3-4: After pressing the plastic part into place, use a screwdriver to tighten the screw clockwise.

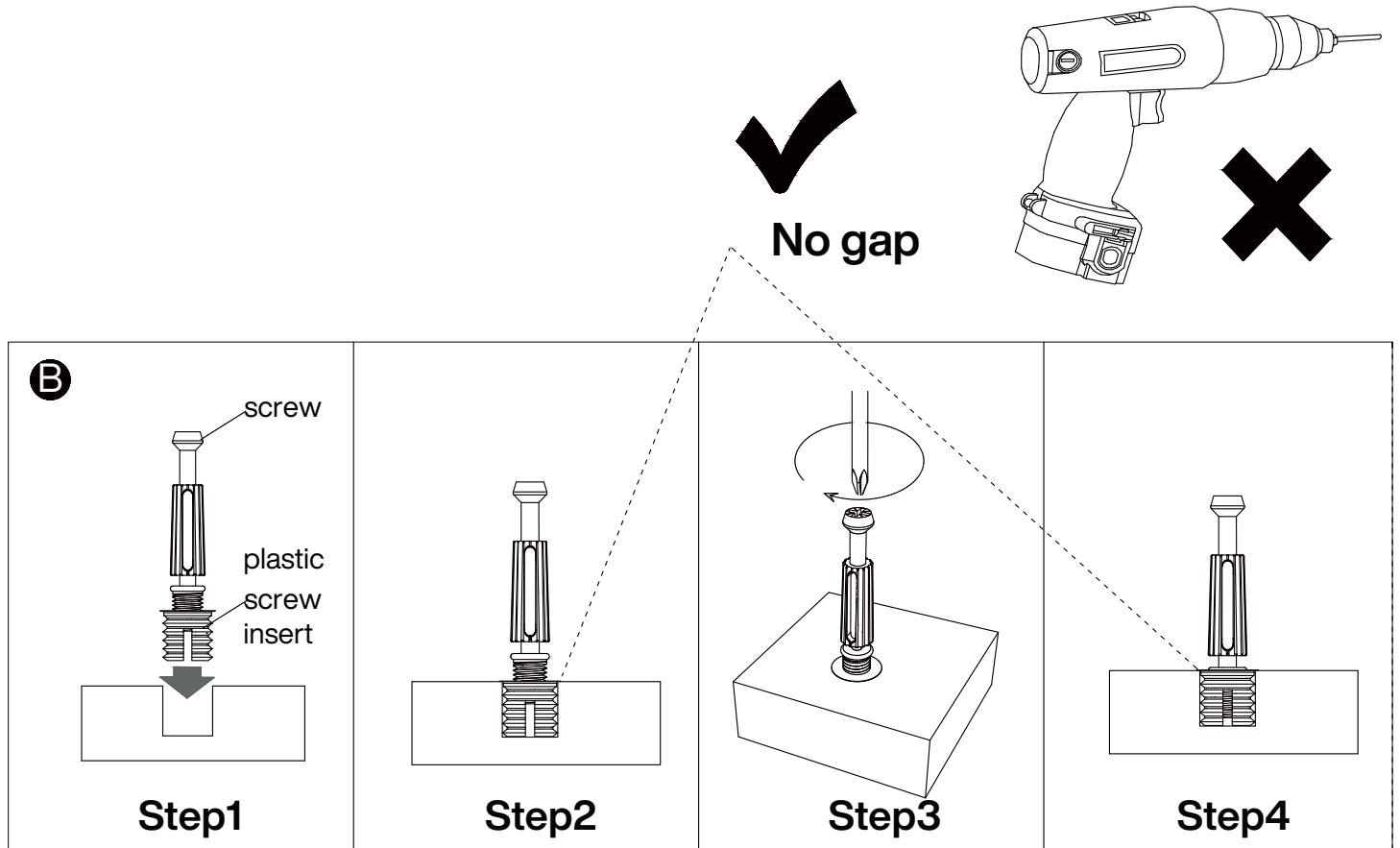

Screw the pin into the hole. Set the cams correctly by aligning the head of the cams with the lock pins. Lock the cam by turning the cam head with a screwdriver until it is tightened. Please do not use an electric screwdriver to assemble the unit.

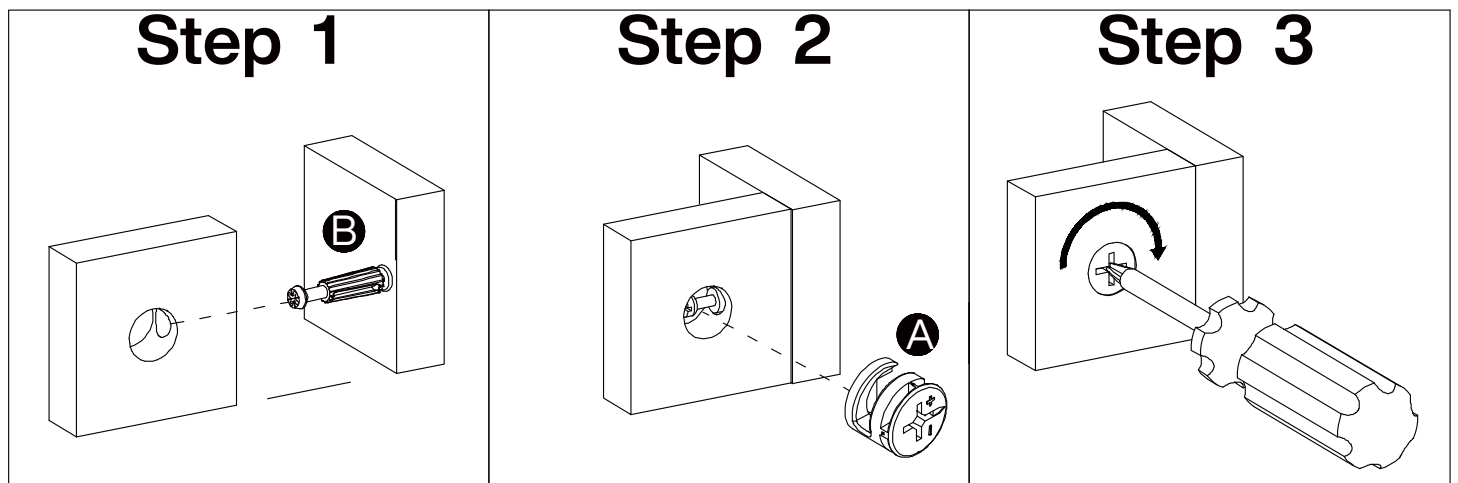

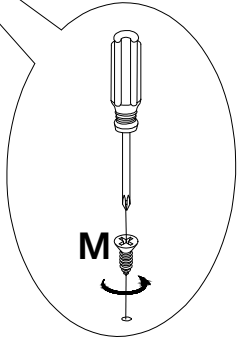
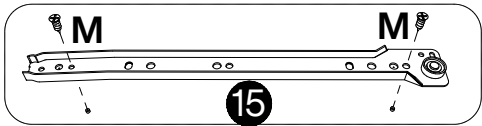
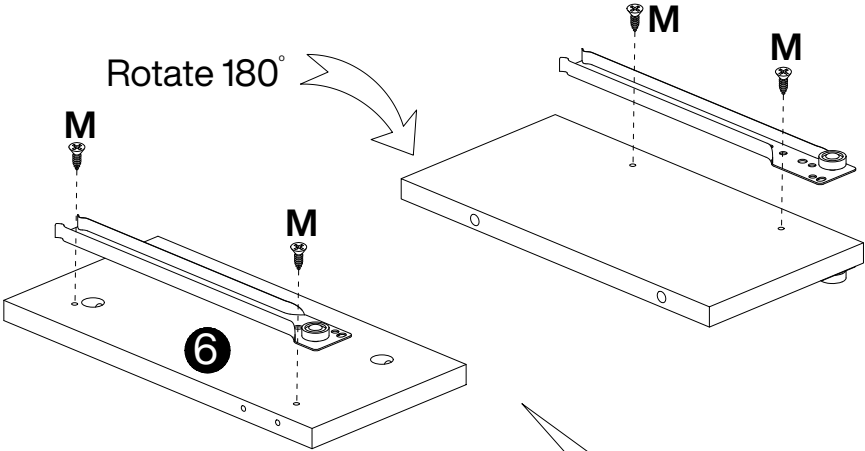
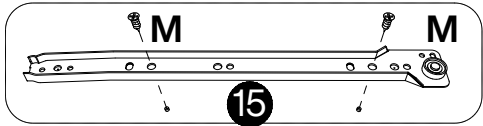

1

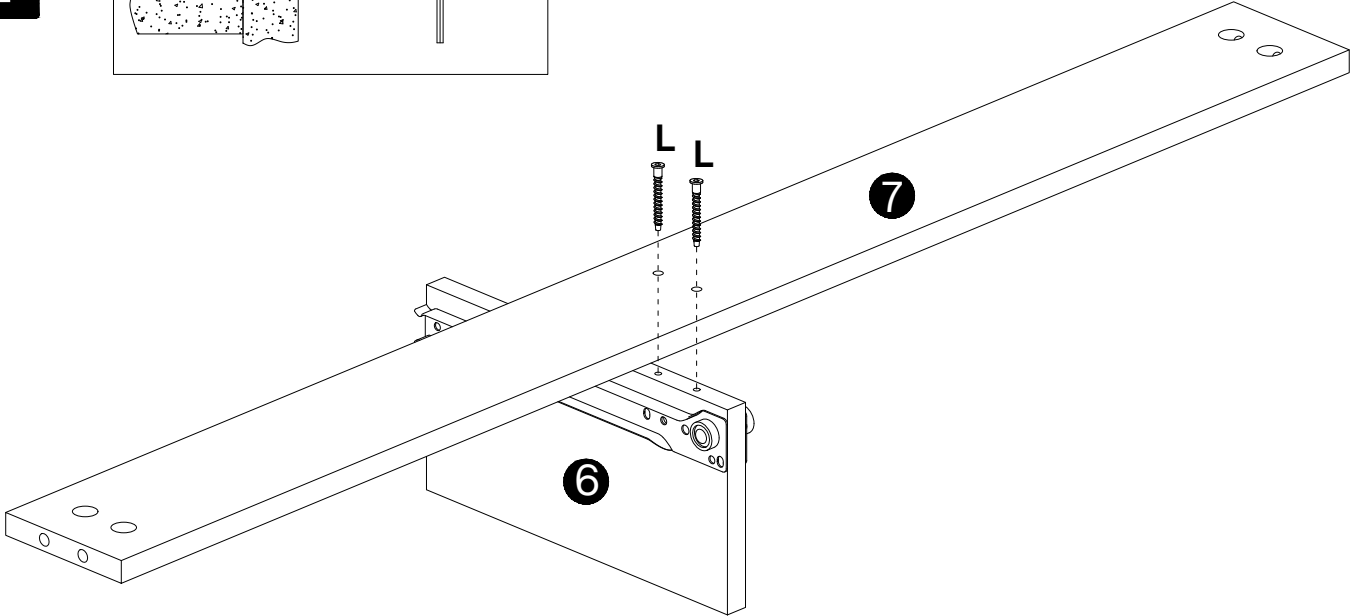
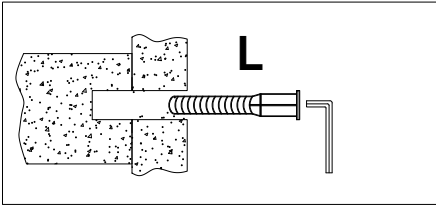

M

M3.5x14mm
4 pcs

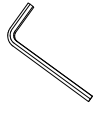
2

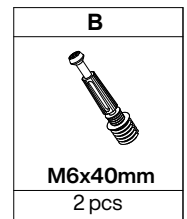
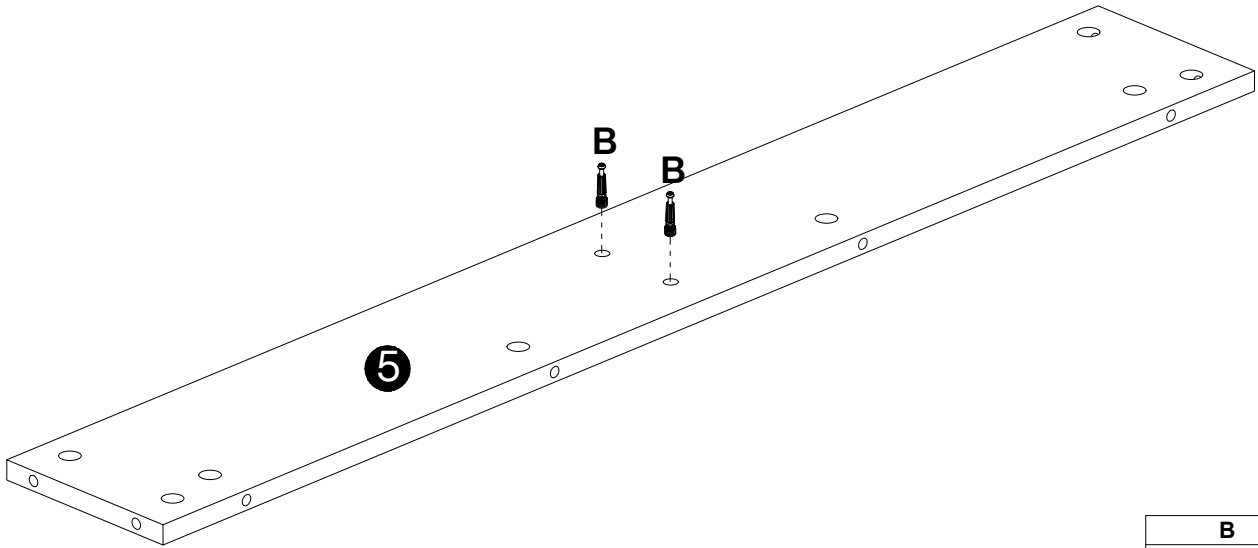
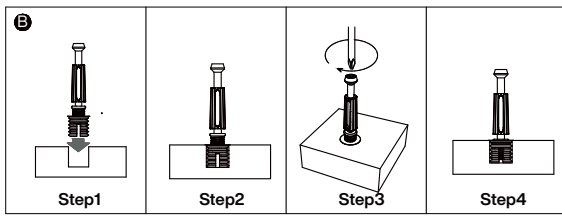

E	L
	
M3	M5x38mm
1 pc	2 pcs

3



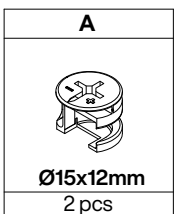
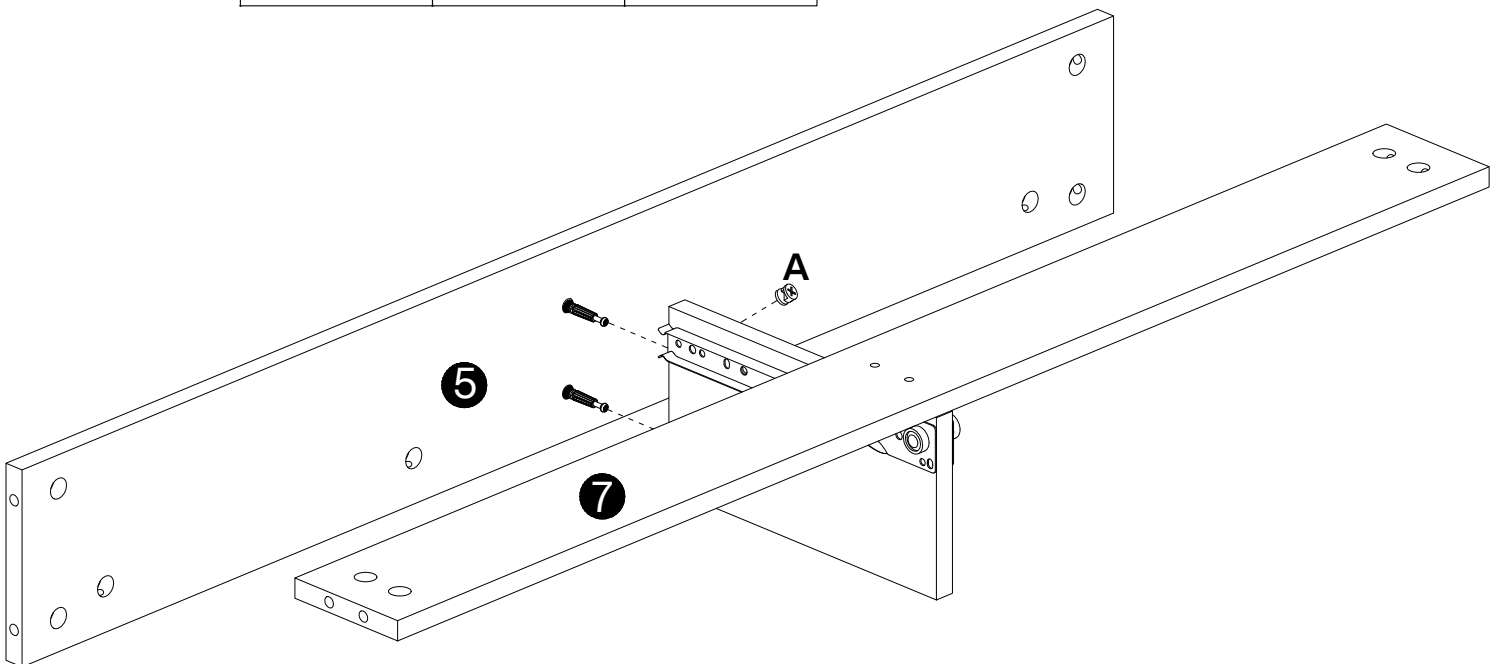
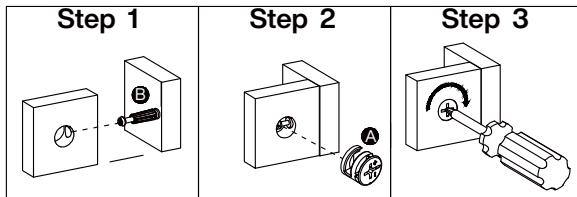

4

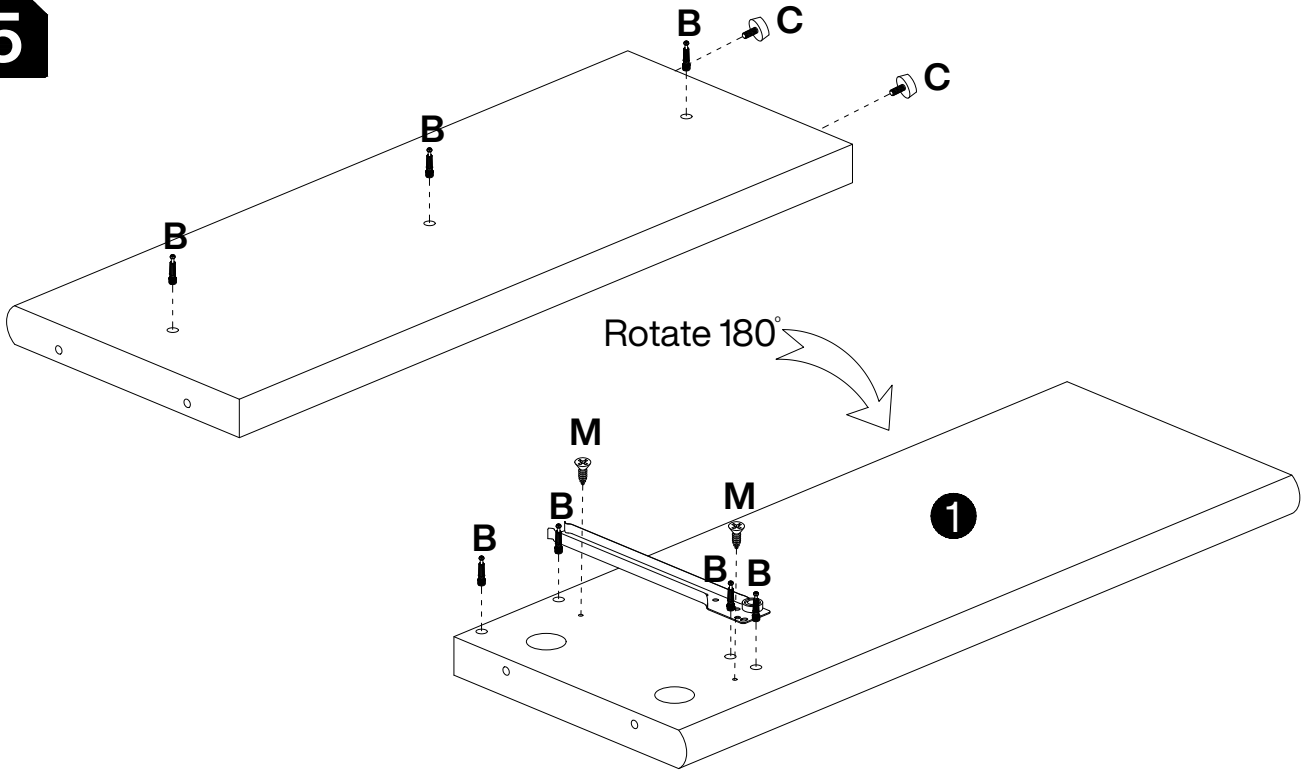

5



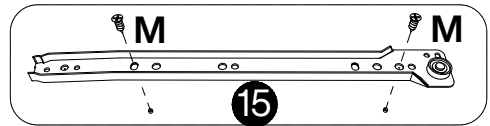

B	C	M
		
M6x40mm 7 pcs	Ø20xM6x15mm 2 pcs	M3.5x14mm 2 pcs

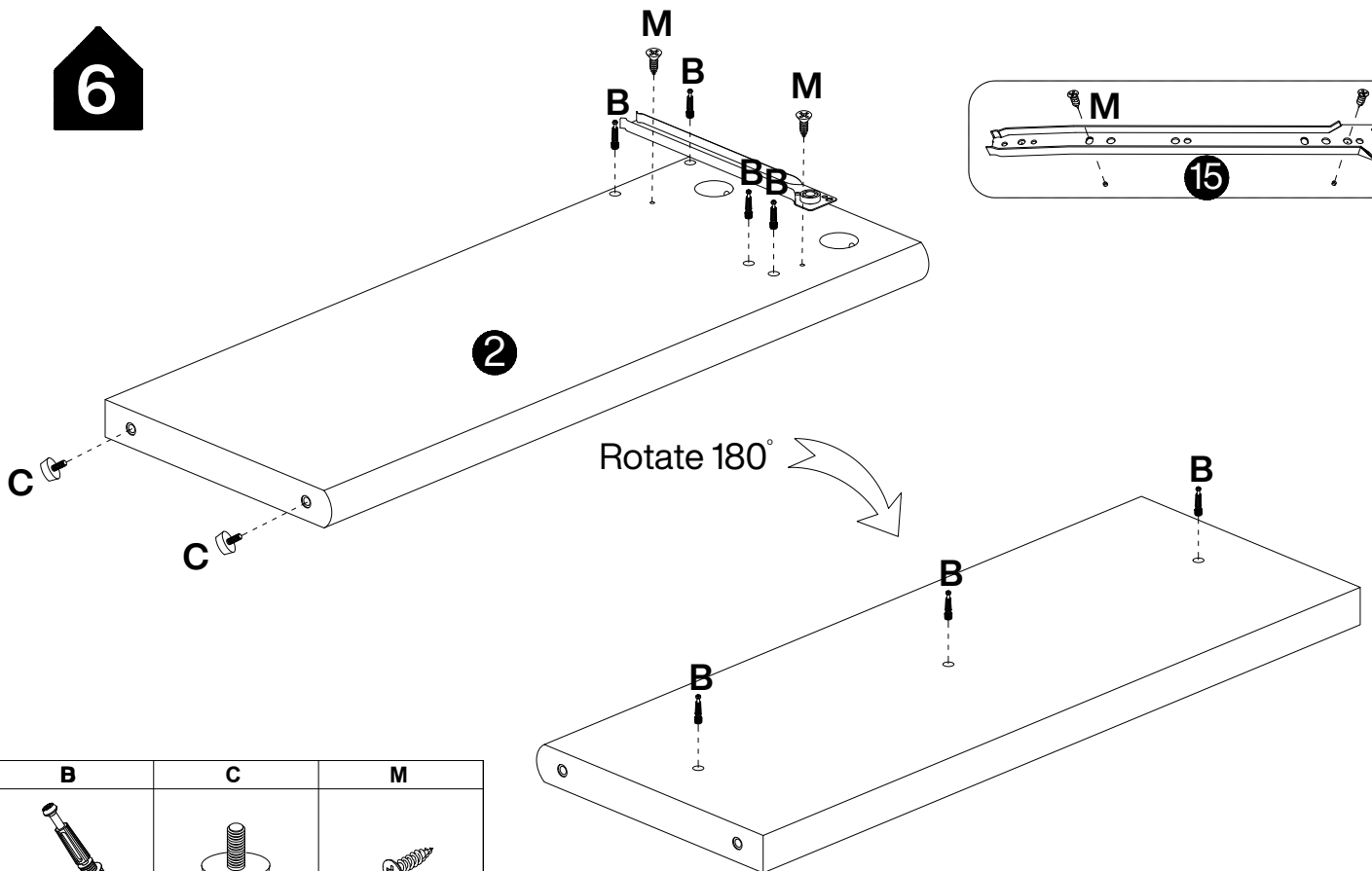

6



B	C	M
		
M6x40mm 7 pcs	Ø20xM6x15mm 2 pcs	M3.5x14mm 2 pcs

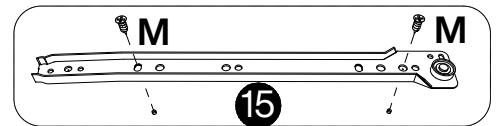

7

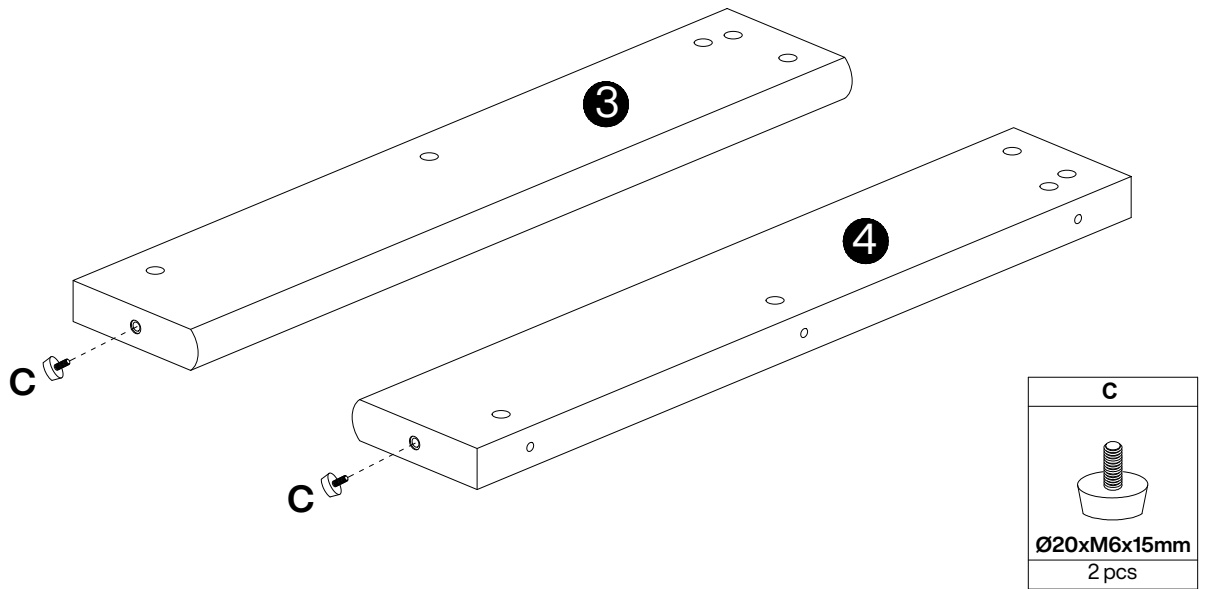

8

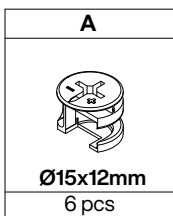
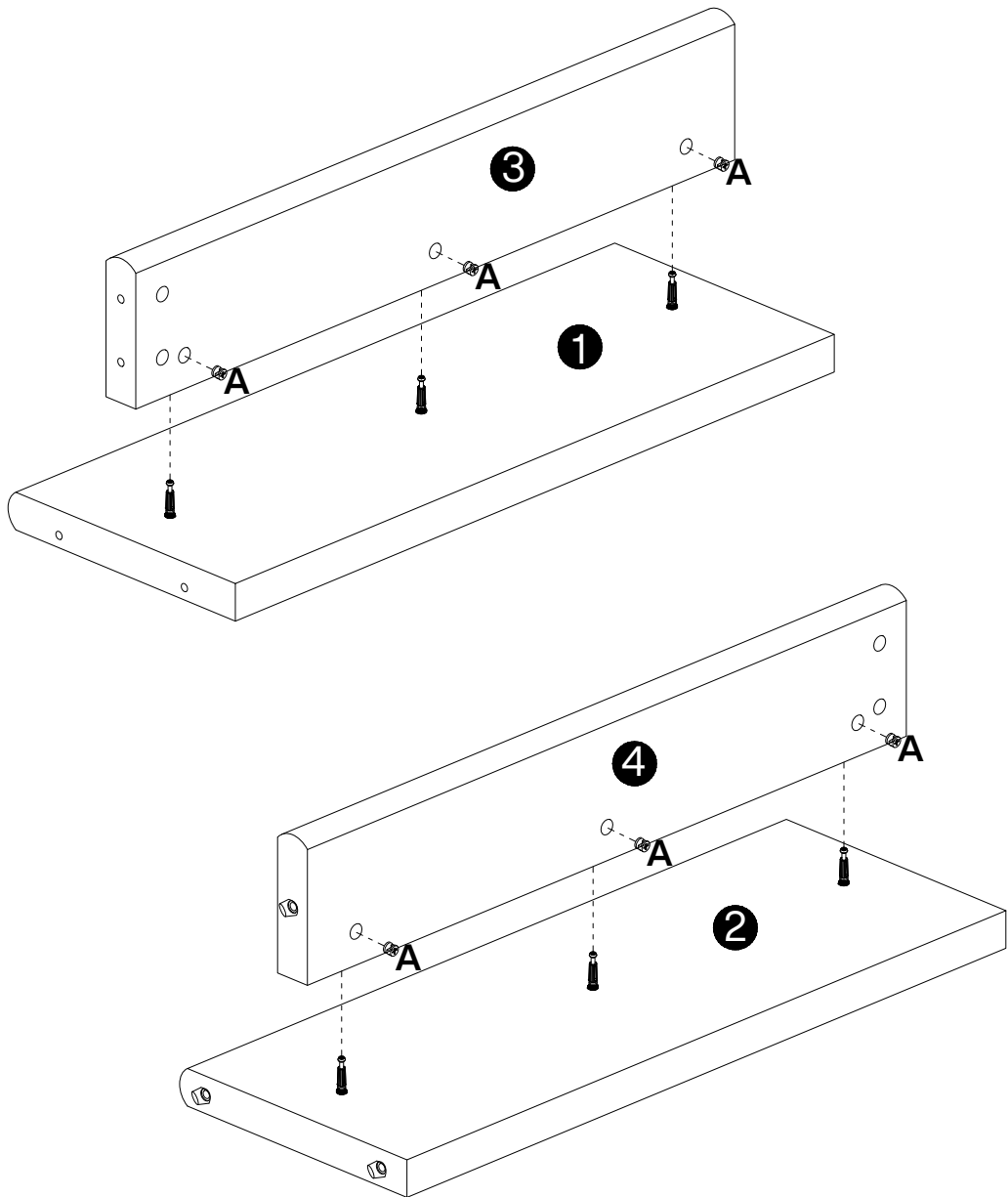

9

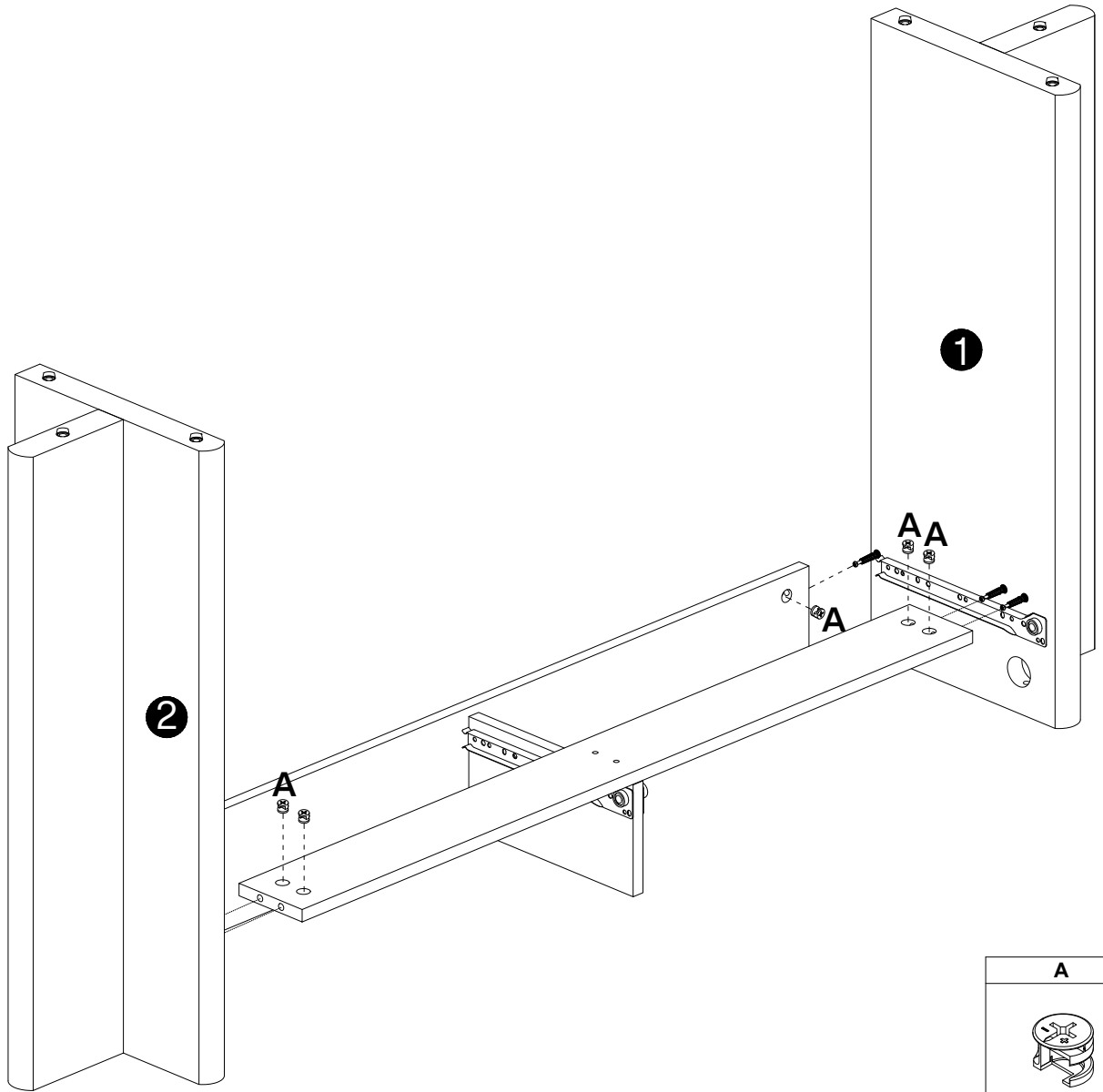

A
Ø15x12mm
8 pcs



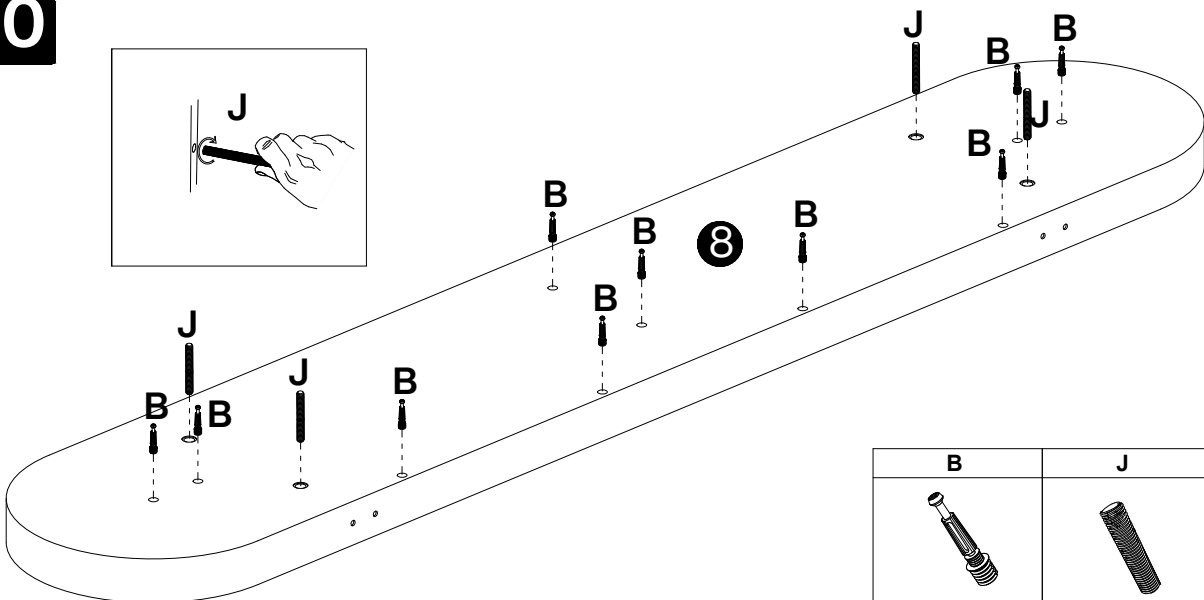

10

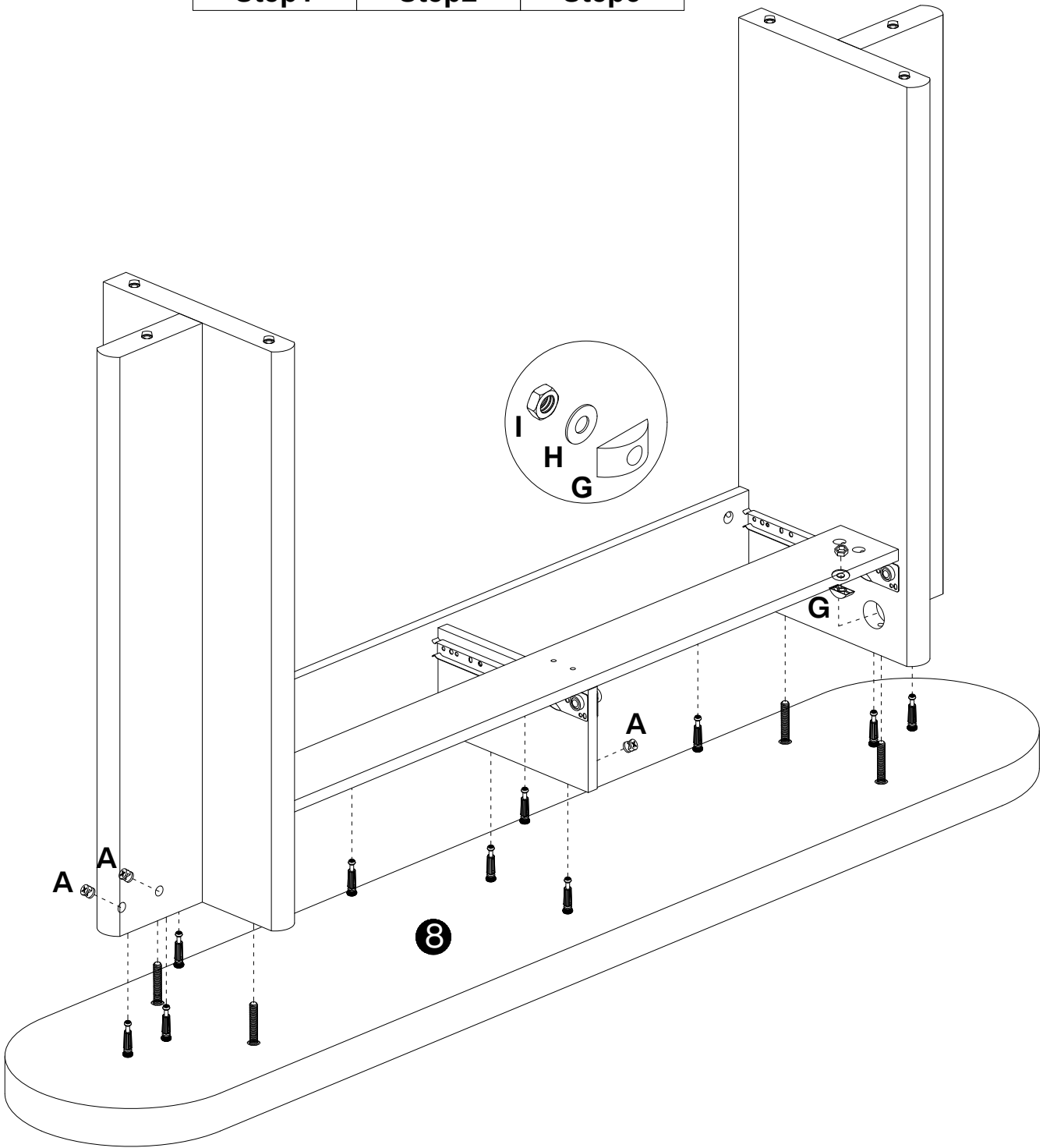
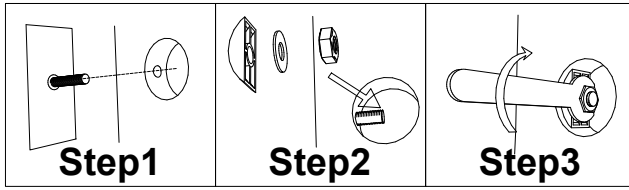

B	J
M6x40mm	M8x70mm
10 pcs	4 pcs



11

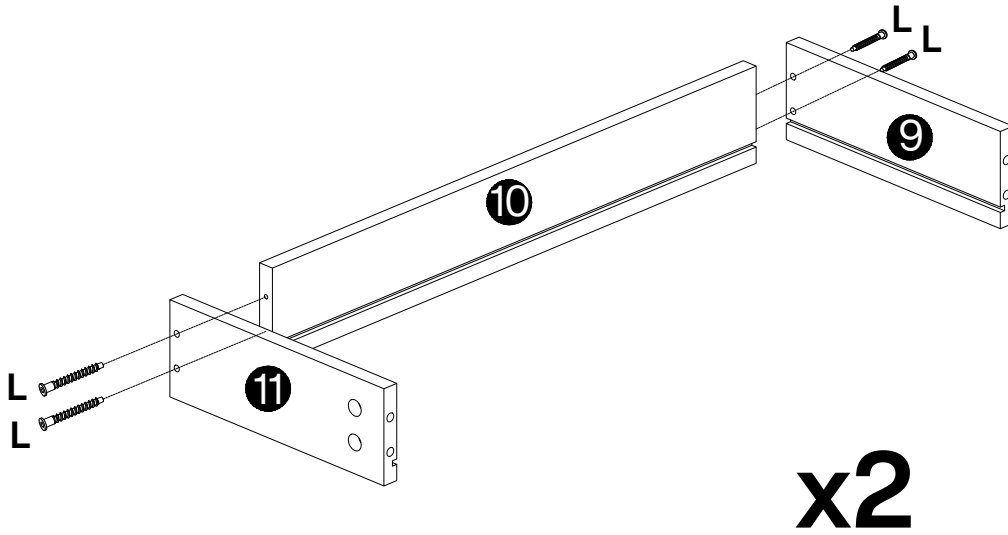

A	F	G	H	I
				
Ø15x12mm 10 pcs	1 pc	4 pcs	4 pcs	4 pcs

12

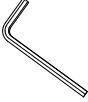

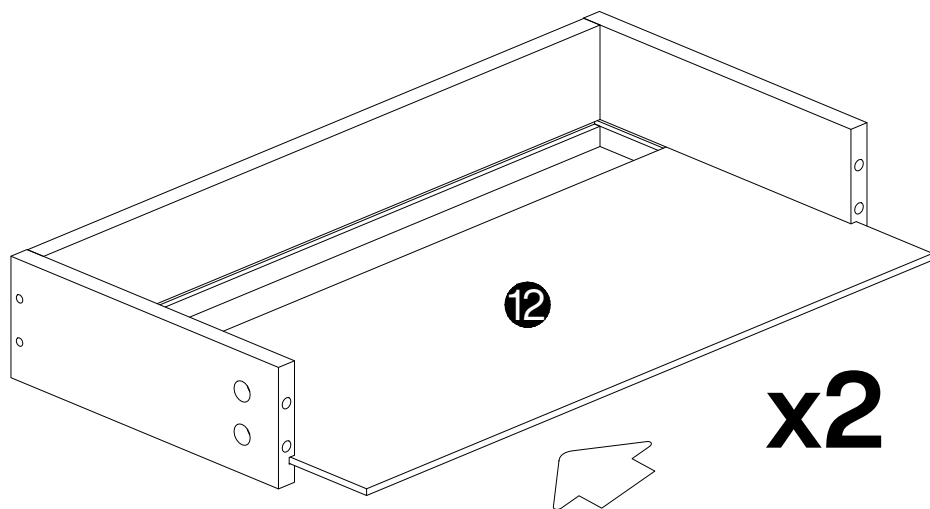

E	L
	
M3 1 pc	M5x38mm 8 pcs

13



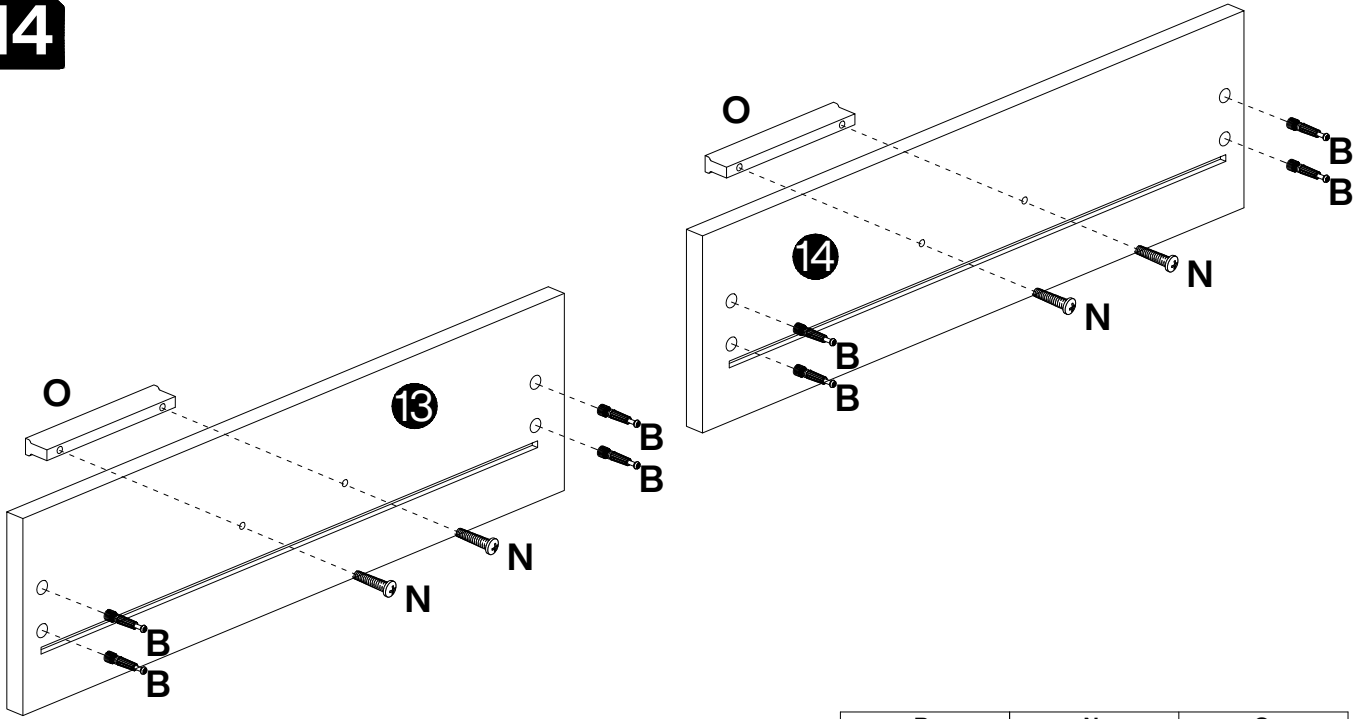

14

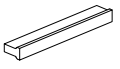

B	N	O
		
M6x40mm 8 pcs	Ø4x20mm 4 pcs	96 2 pcs

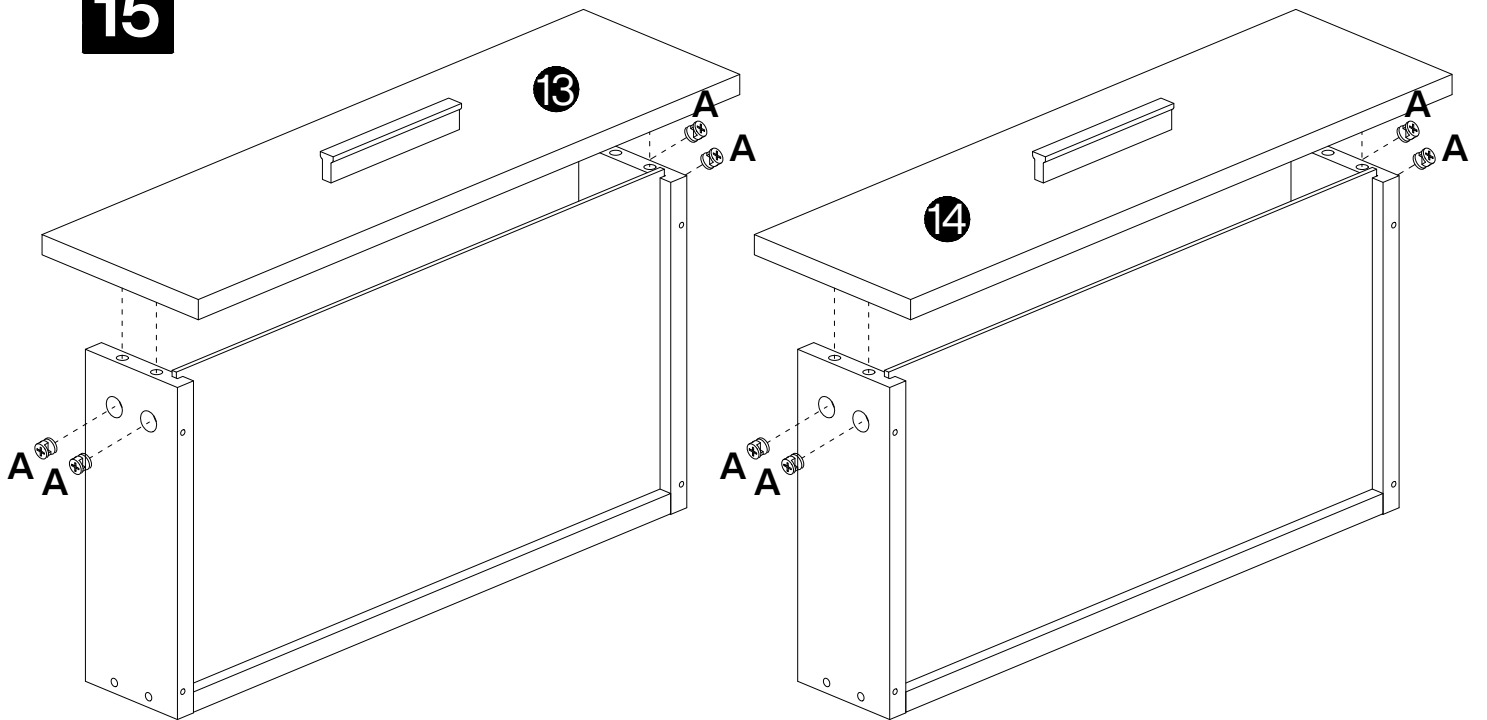
15



A

Ø15x12mm 8 pcs

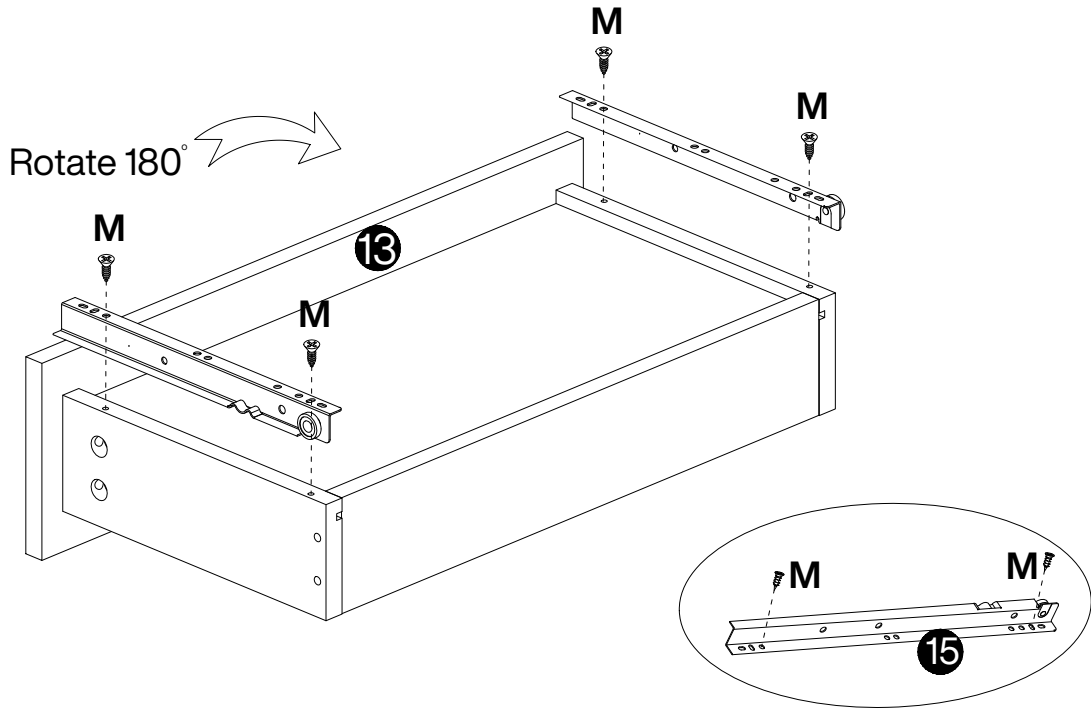
16

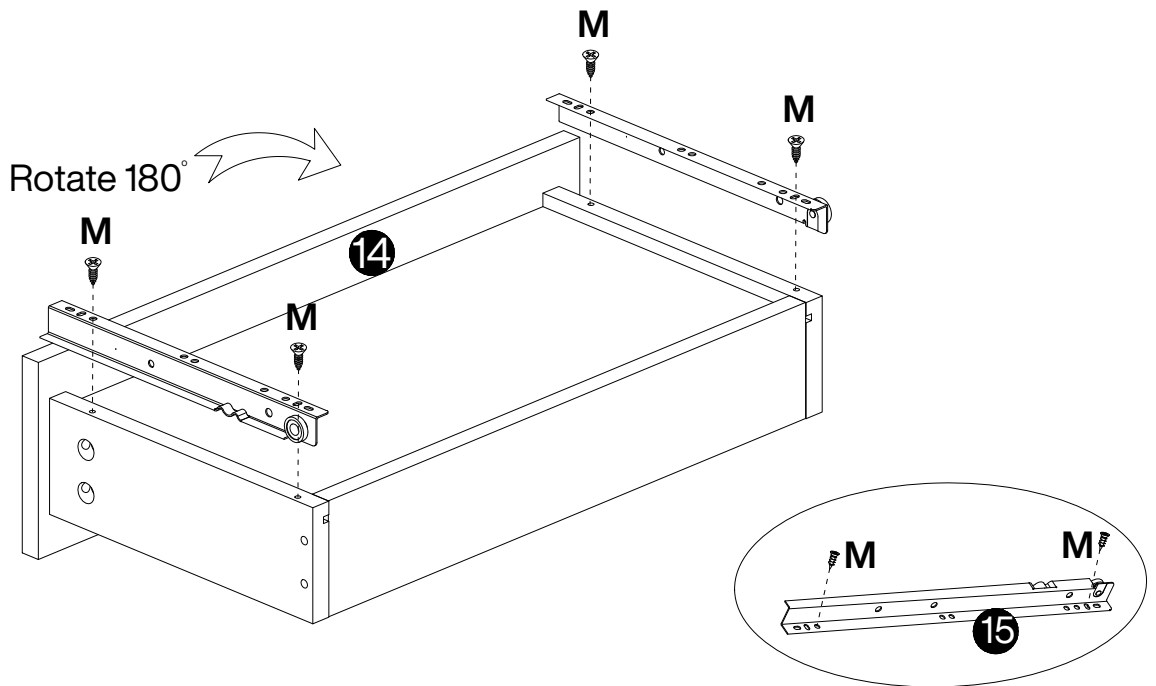

M

M3.5x14mm
4 pcs

17

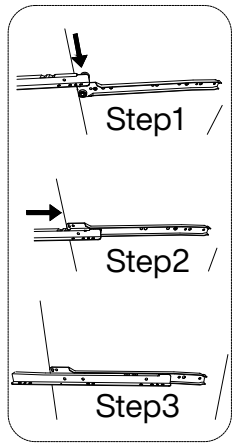
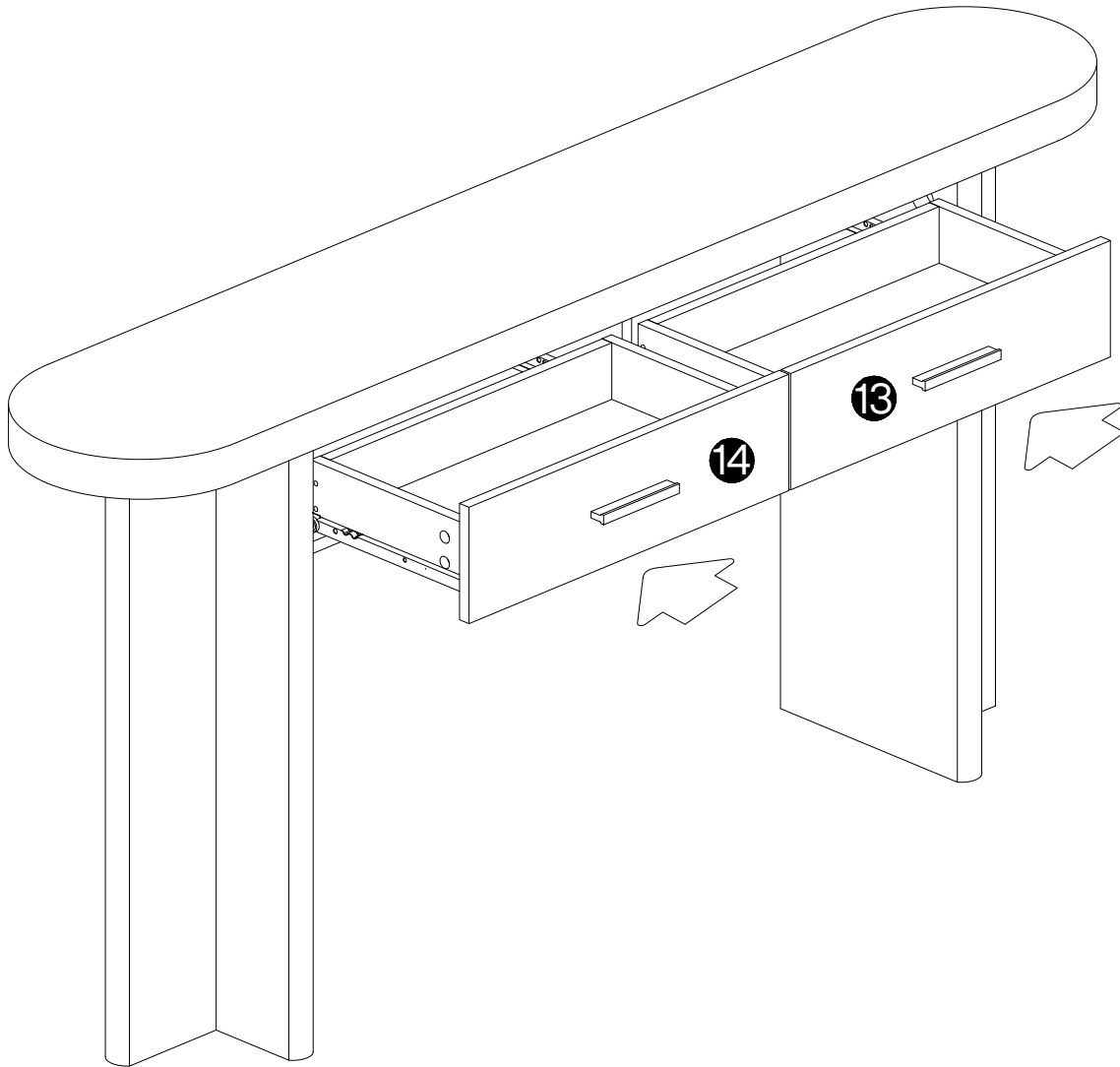

M

M3.5x14mm
4 pcs

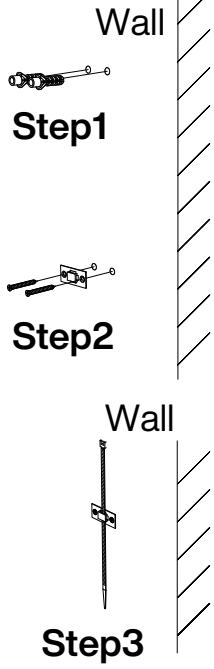
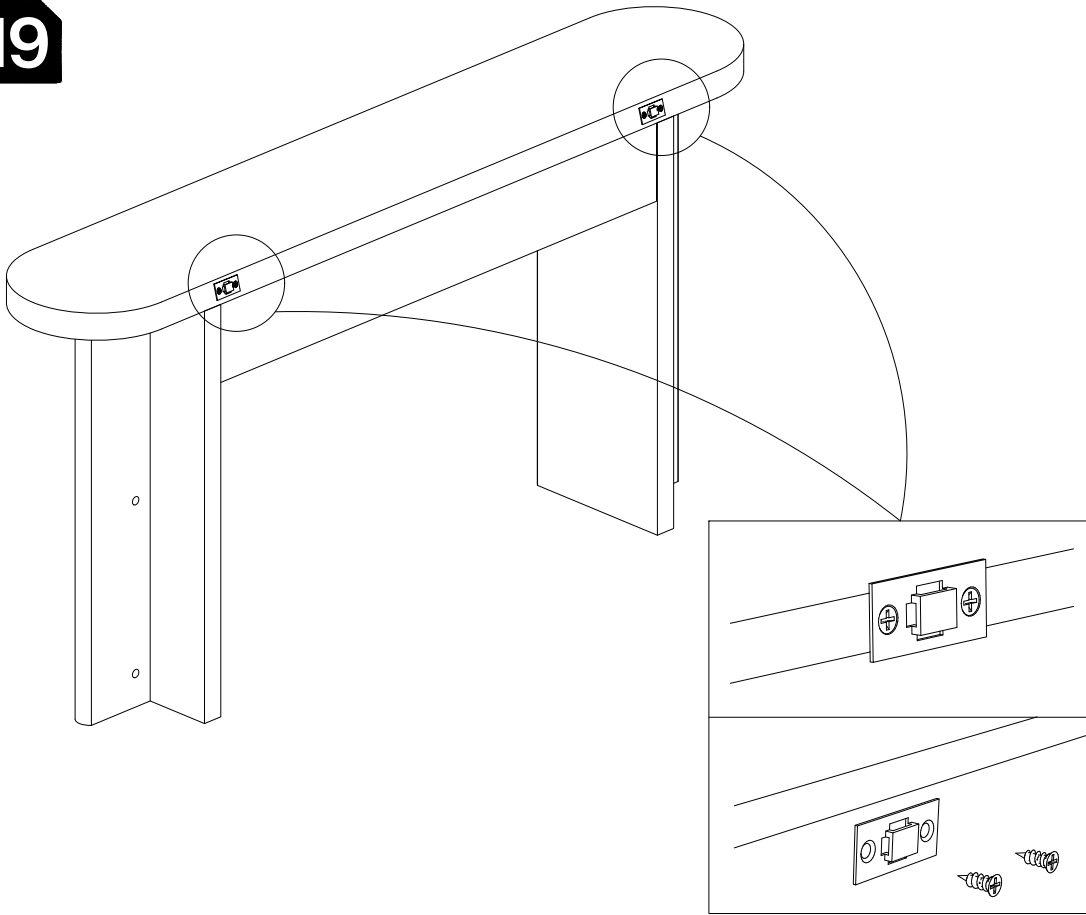

19



20

