











Assembly Instructions

Caution : You must read this before you proceed

Care & Maintenance

- ⊘  • Not for commercial use. For residential use only.
- ⊘  • Prolonged exposure to rain may cause rusting which can stain floors.
- ⊘  • Do not put hot items directly on furniture surface.
- ⊘  • Do not clean furniture with harsh cleansers or polish.
- ✓  • To obtain the longest lifespan of your outdoor products, minimizing exposure to direct sunlight is recommended.
- ⊘  • Children should not climb or jump on the furniture.
- ⊘  • Do not write on furniture without a padded barrier to protect the surface.
- ✓  • To obtain the longest lifespan of your outdoor products, avoid extended and lengthy exposure to rain, snow, and direct sunshine. Whenever possible cover the product and /or place under patio or awnings.
- ⊘  • Stains may be removed with mild soap solution and damp cloth.
- ✓  • Keep away from sources of ignition.
- ✓  • Dust and pick-up spills using a clean, non-colored, lint-free cloth.

Please look into the Seat Panel for hardware packs

Armchair

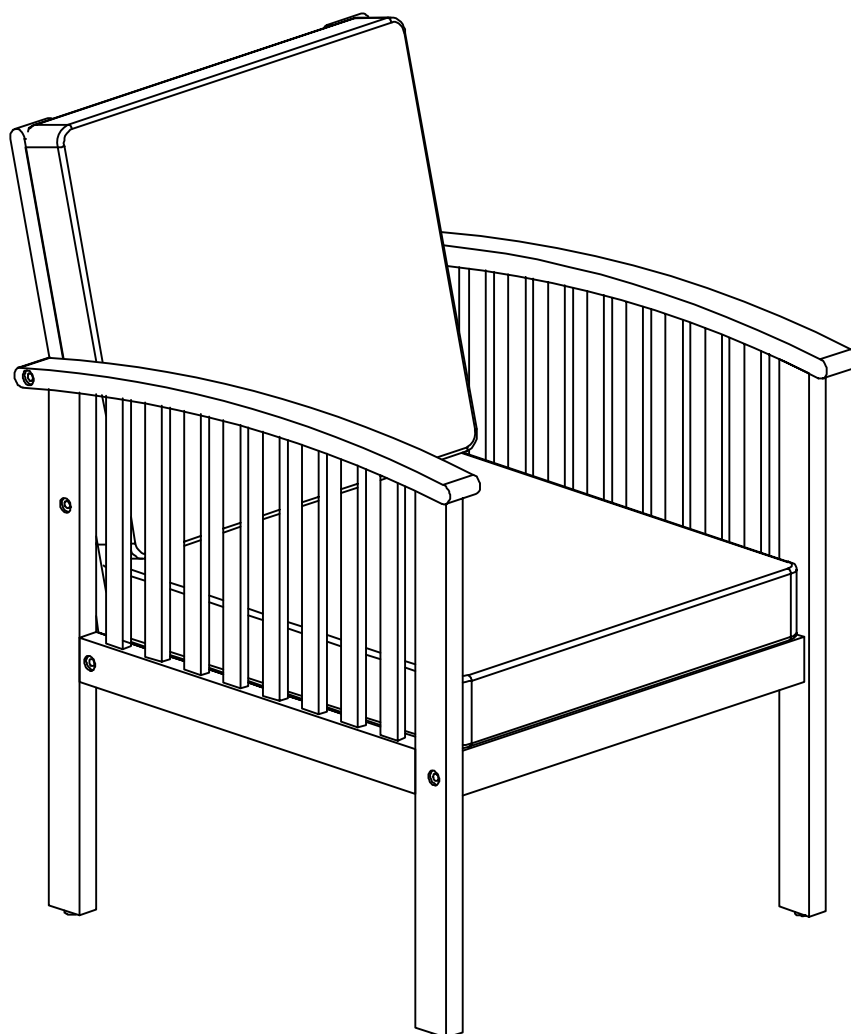

Caution: This Chair is NOT a TOY.



Keep your child/children at bay during the assembly process.

Whenever lifting or moving the Chair and to prevent damage to the chair, two adults may be needed to execute these actions.

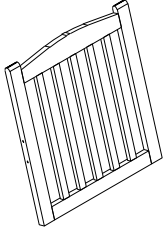
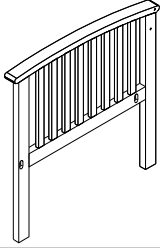
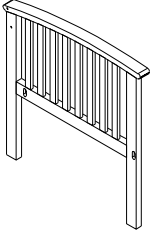
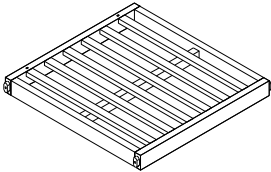
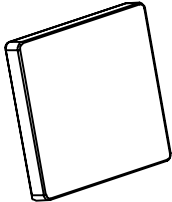
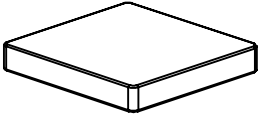
Parts List

Label	Picture	Description	QTY
A		Backrest Panel	2
B		Left Arm with Leg Panel	2
C		Right Arm with Leg Panel	2
D		Seat Panel	2
E		Back Cushion	2
F		Seat Cushion	2

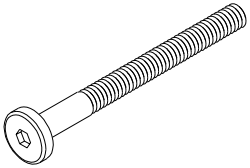
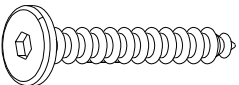
Hardware List

<p>①</p>  <p>4pcs (Extra 1pc) Bolt (M6x65)</p>	<p>②</p>  <p>4pcs (Extra 1pc) Screw (M7x50)</p>	<p>③</p>  <p>12pcs (Extra 1pc) Screw (M7x70)</p>	<p>④</p>  <p>1pc Allen Wrench (M4)</p>
---	--	--	---

Assembly Preparation

Before Beginning Assembly

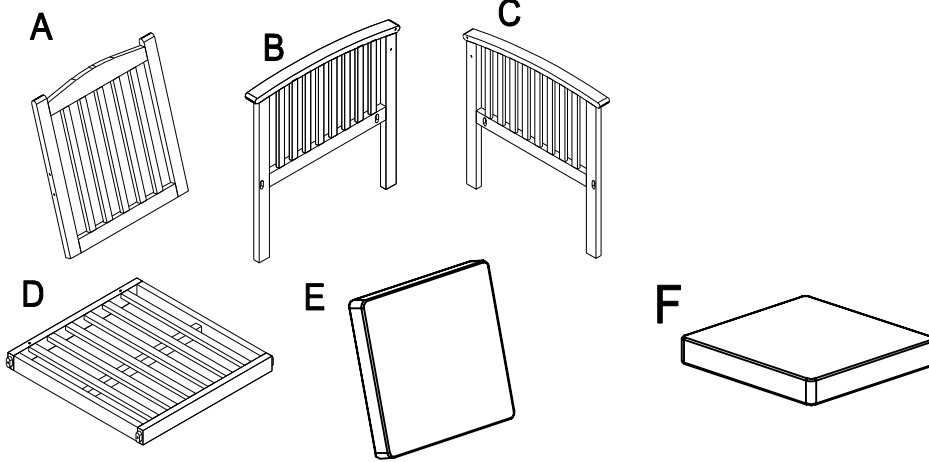

- ① x 4 +1
- ② x 4 +1
- ③ x 12 +1
- ④ x 1



- Read instructions, cover to cover.



- Have 2 adults on hand for assembly.



- Do not assemble on flooring or carpet.



- Assemble on a clean non-marring surface (packing foam).

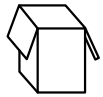

- Save all packaging until finished.

Assembly Preparation

Overview

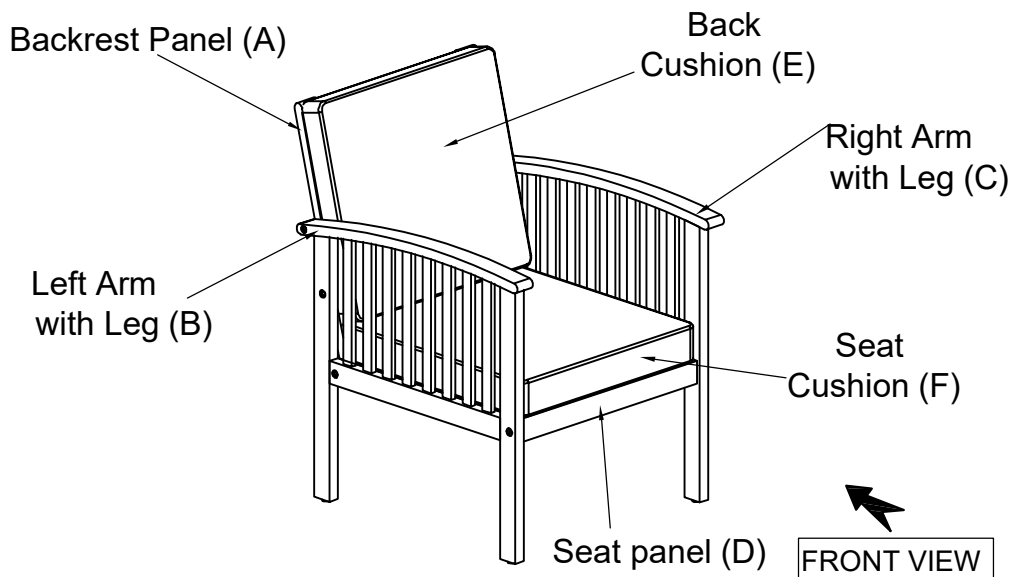

This Chair has multiple parts and may require up to some 30 minutes to assemble. To give you an overview of the Chair, the above picture is to help you put the various parts into perspective. Please read through the instructions here below to familiarise the parts and steps before assembly.

Step 1

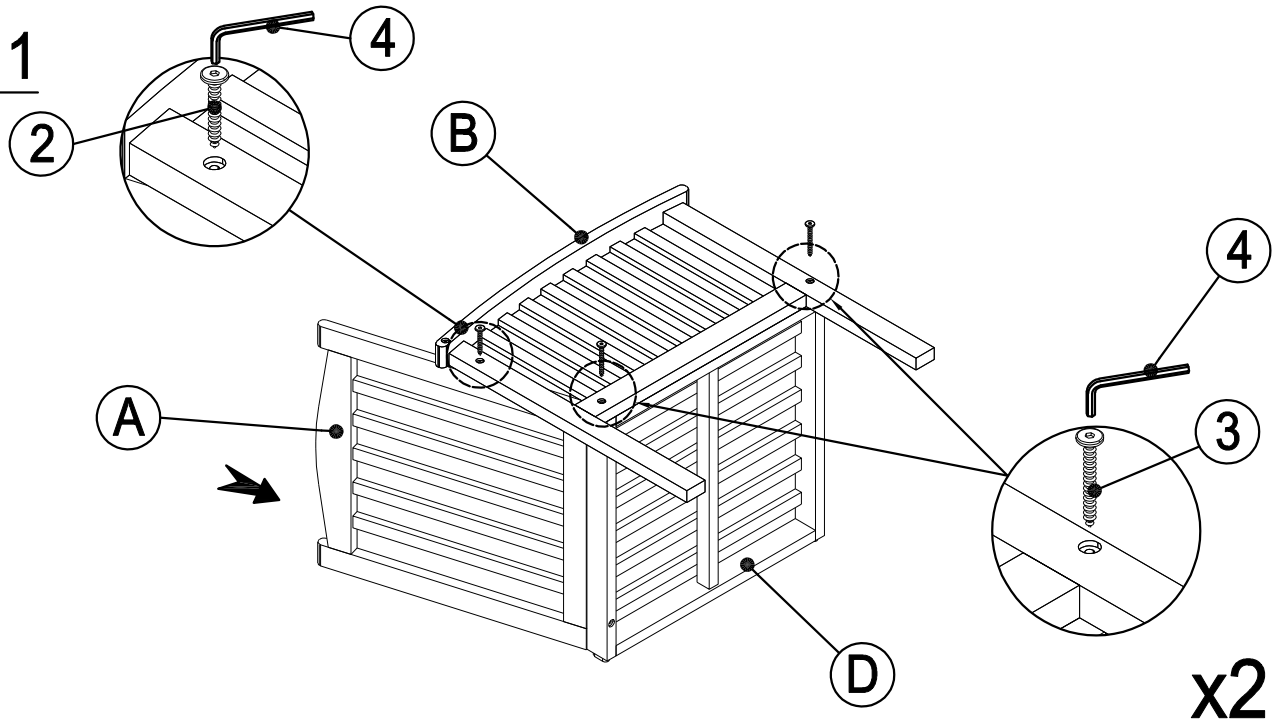

Place all the parts on a clean, non-marring surface.

Attach Left Arm with Leg Panel (B) together with Seat Panel (D) and Backrest Panel (A)

Lock in the mounting position, using screws(2), screws (3) and Allen Wrench (4).

Do not fully tighten the Screws.

Step 2

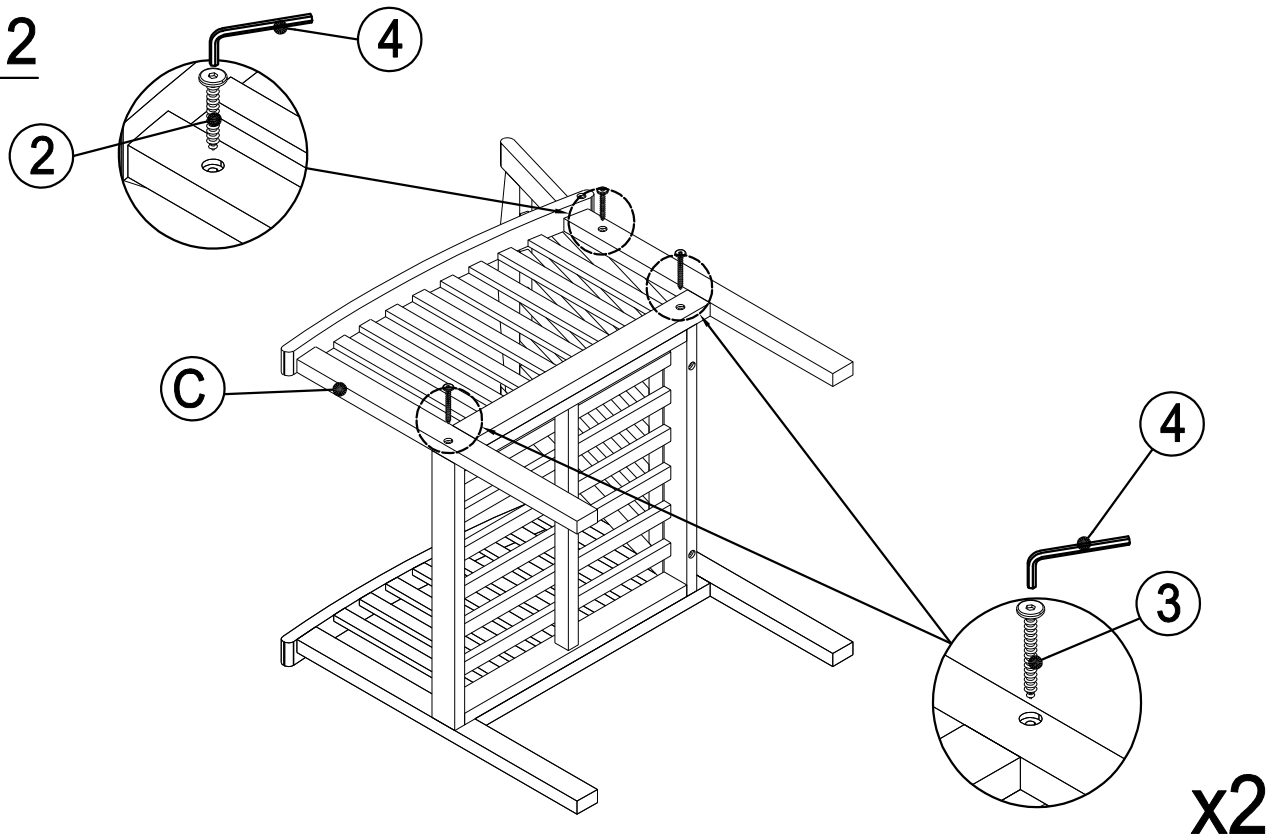

You will now have the seat Panel (D) and Backrest Panel (A), Left Arm with Leg Panel(B)

Insert the Right Arm with Leg Panel(C).

Lock in the mounting position, using screws(2), screws (3) and Allen Wrench (4)..

Do not fully tighten the Screws.

Step 3

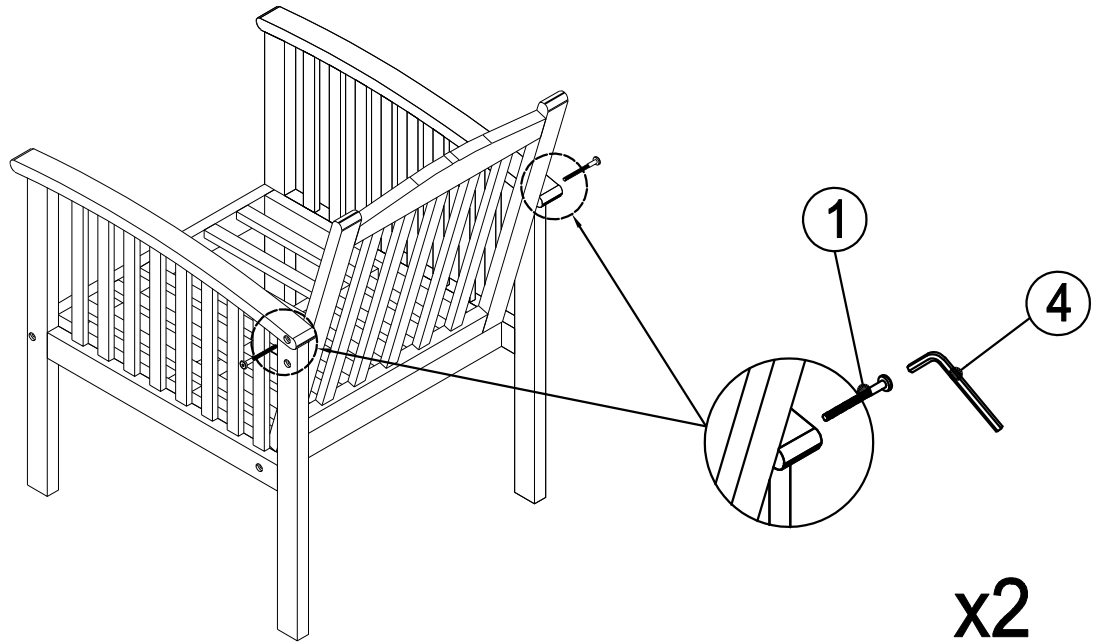

Use Bolt (1) and Allen Wrench (4) to affix the top of the Backrest to the Armrests on both sides as shown.
Do not fully tighten the Bolts

Step 4

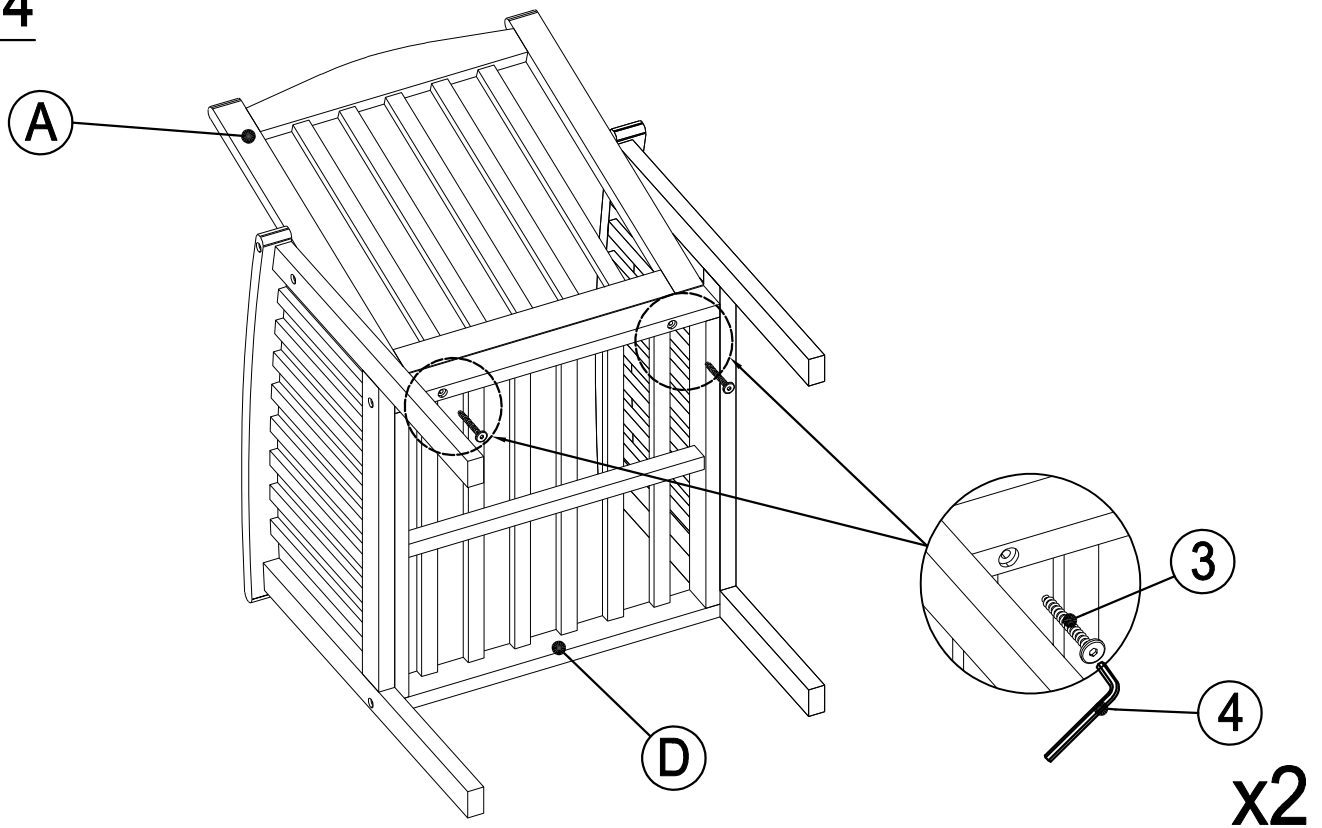

Use Screw (3) and Allen Wrench (4) to attach Backrest Panel (A) and Seat Panel (D).
Do not fully tighten the Screws.

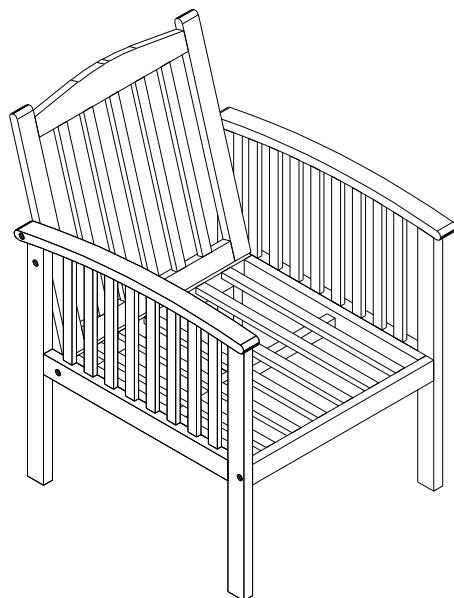

x2

Turn the Chair right side up.
Inspect it and make sure all parts are adequately connected.
Ensure all bolts and screws are fully locked into position and secured.

Step 4

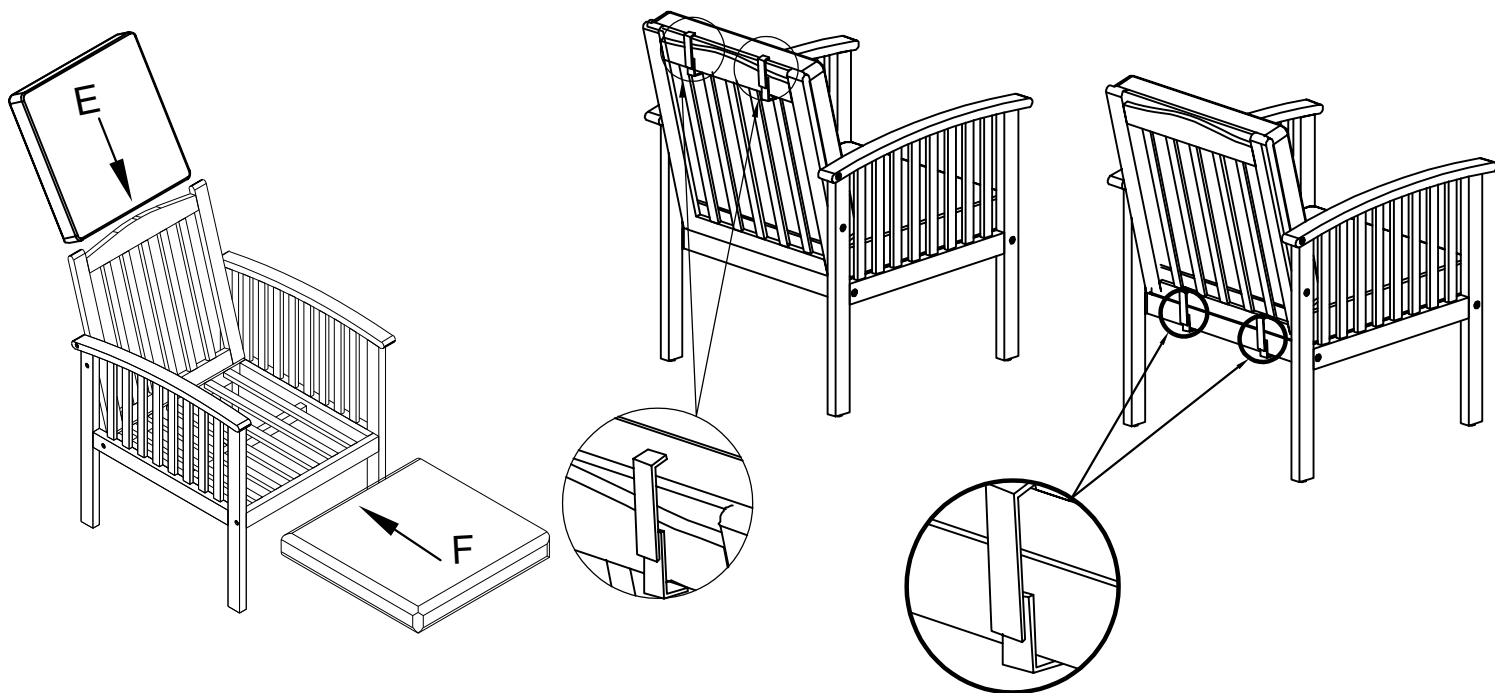

x2

Next, install the Seat Cushion (F) & Back Cushion (E) into the Chair.
Tie the magic tape straps of Seat Cushion (F) and Back Cushions (E) to Seat .
Panel (D) and Backrest Panel (A) as pictured.
Your Chair is ready for use.
This chair can only be used on flat, level surface.

Please look into the Seat Panel for hardware packs

BENCH

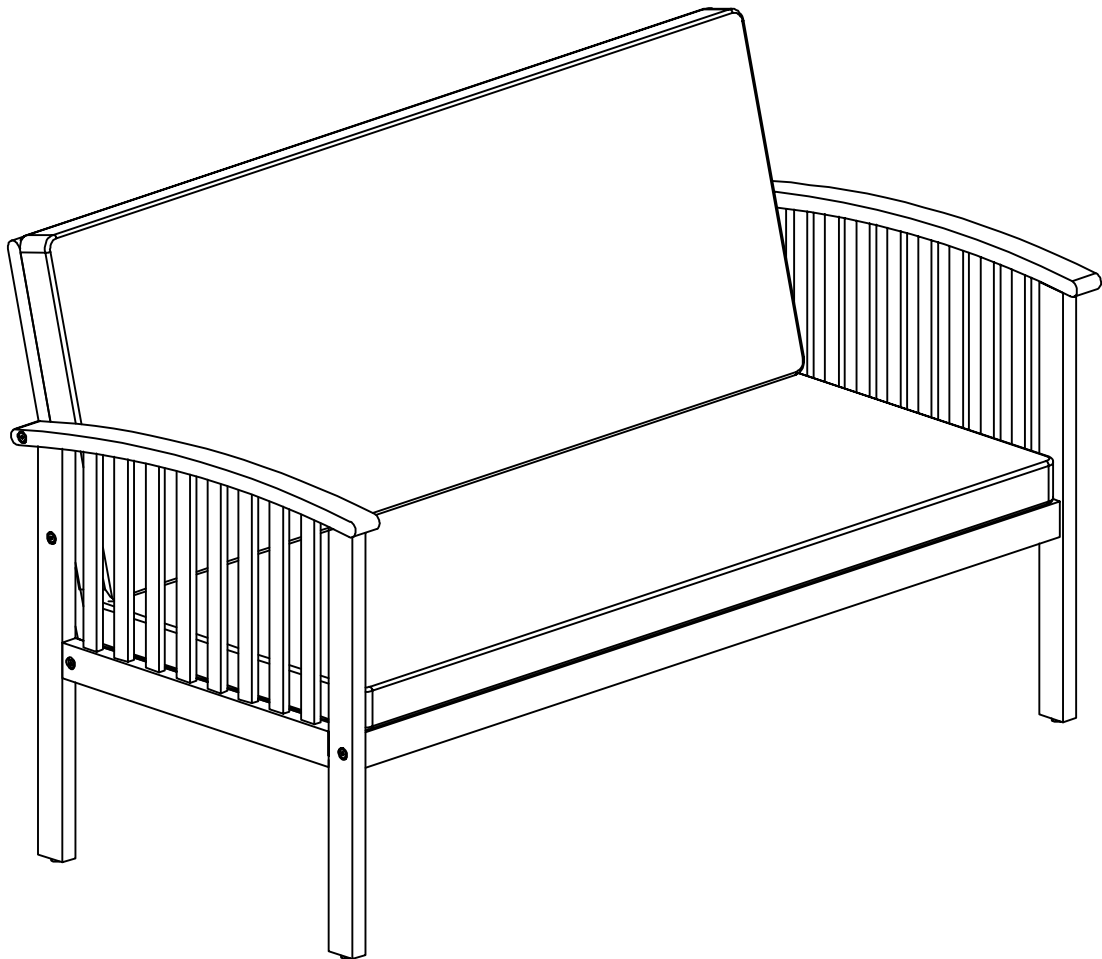

Caution: This Bench is NOT a TOY.



Keep your child/children at bay during the assembly process.

For turning the Bench and to prevent damage to the Bench , 02 persons may be be needed to execute this action.

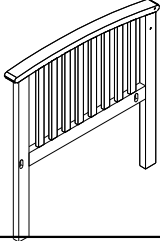
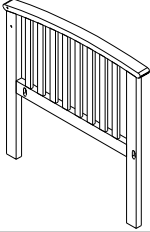
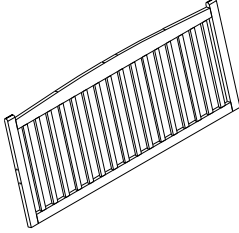
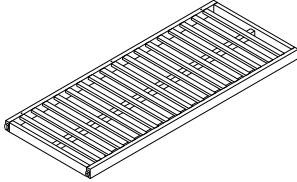
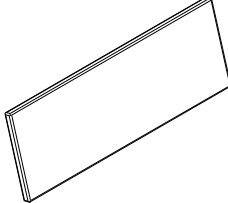
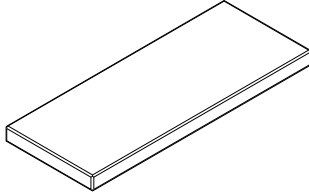
Parts List

Label	Picture	Description	QTY
B		Left Arm with Leg Panel	1
C		Right Arm with Leg Panel	1
G		Backrest Panel	1
H		Seat Panel	1
I		Back Cushion	1
J		Seat Cushion	1

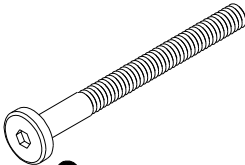

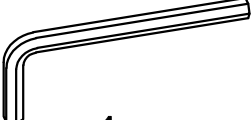

Hardware List

<p>①</p>  <p>2pcs (Extra 1pc) Bolt (M6x65)</p>	<p>②</p>  <p>2pcs (Extra 1pc) Screw (M7x50)</p>	<p>③</p>  <p>7pcs (Extra 1pc) Screw (M7x70)</p>	<p>④</p>  <p>1pc Allen Wrench (M4)</p>
---	--	---	---

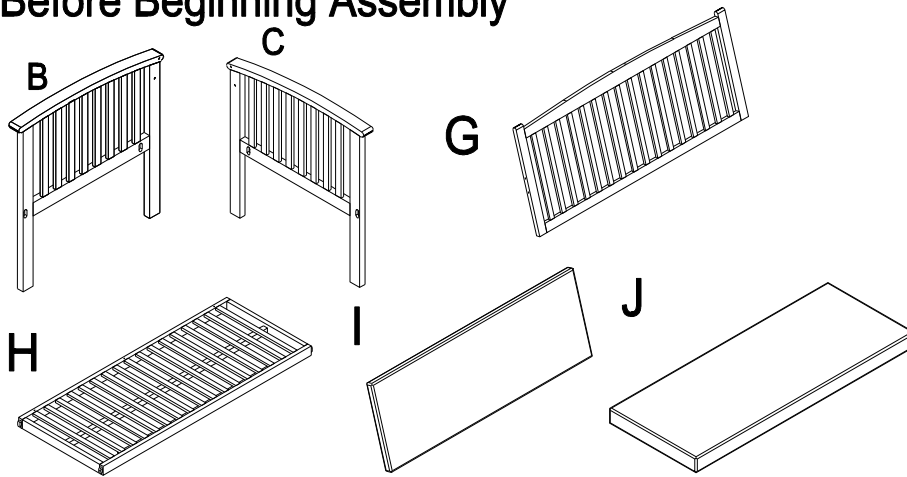
Assembly Preparation

Before Beginning Assembly



- ①  x 2 +1
- ②  x 2 +1
- ③  x 7 +1
- ④  x 1



- Read instructions, cover to cover.



- Have 2 adults on hand for assembly.



- Do not assemble on flooring or carpet.



- Assemble on a clean non-marring surface (packing foam).

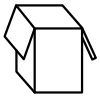

- Save all packaging until finished.

Assembly Preparation

Overview

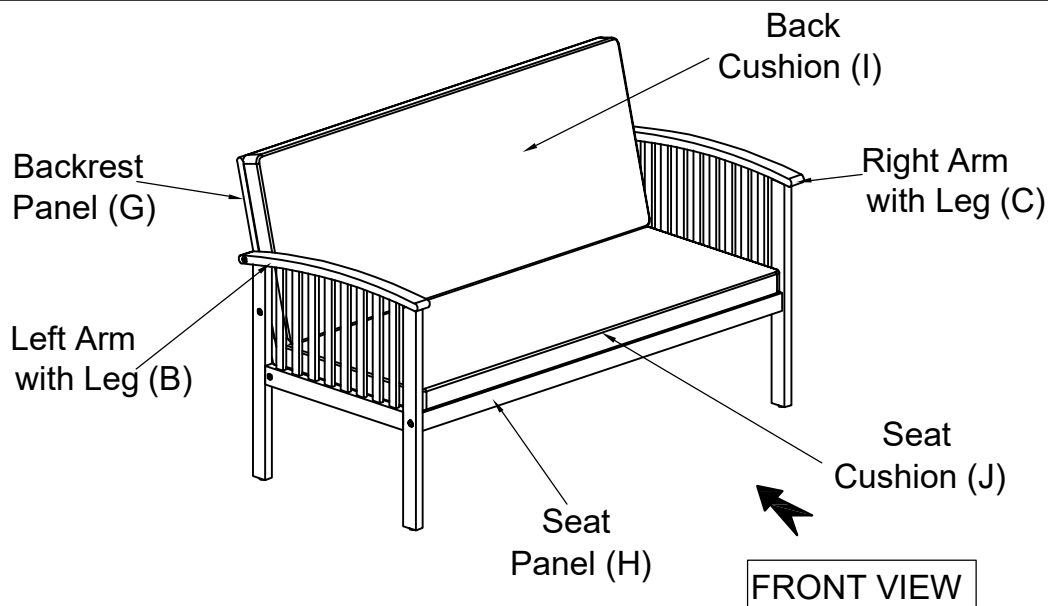

This Bench has multiple parts and may require up to some 30 minutes to assemble. To give you an overview of the Bench, the above picture is to help you put the various parts into perspective. Please read through the instructions here below to familiarise the parts and steps before assembly.

Step 1

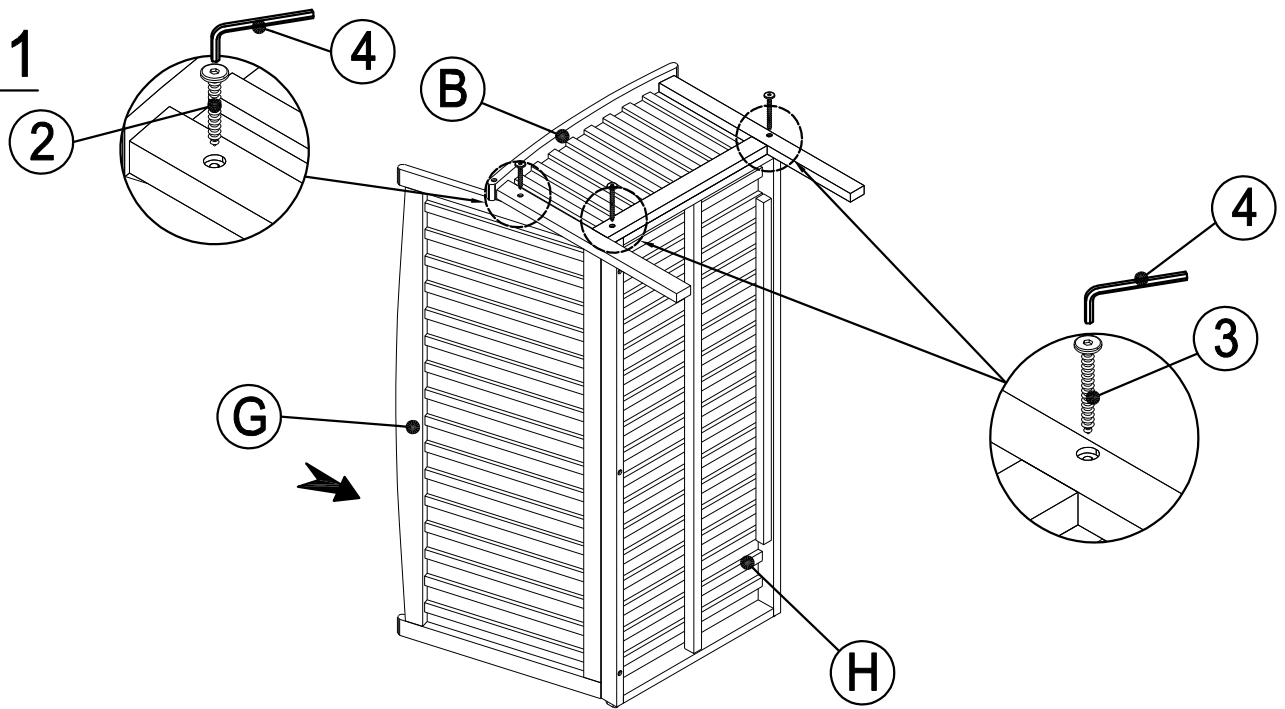

Place all the parts on a clean, non-marring surface.

Attach Left Arm with Leg Panel (B) together with seat Panel (H) and Backrest Panel (G)

Lock in the mounting position, using screws (2), screws (3) and Allen Wrench (4).

Do not fully tighten the Screws.

Step 2

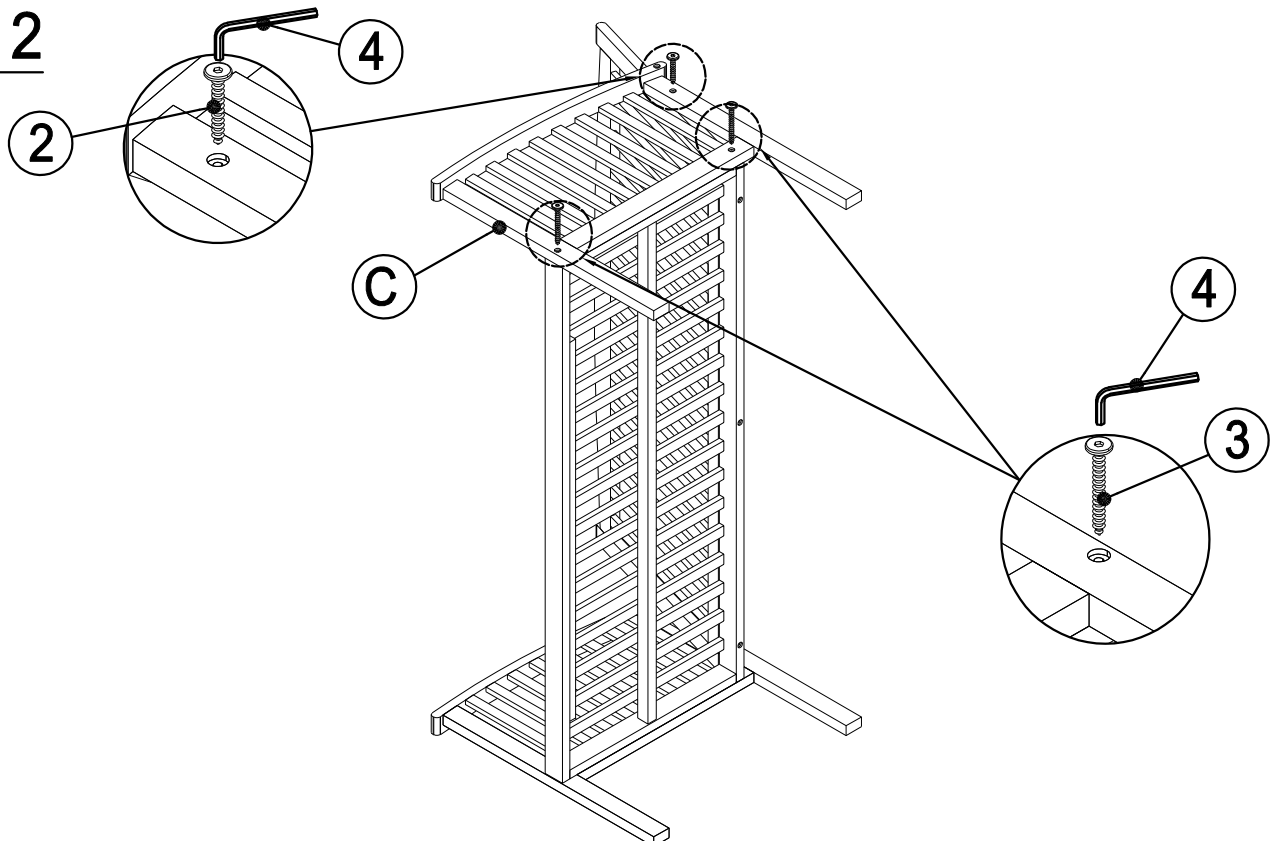

You will now have the seat Panel (H) and Backrest Panel (G), Left Arm with Leg Panel (B)

Insert the Right Arm with Leg Panel (C).

Lock in the mounting position, using screws (2), screws (3) and Allen Wrench (4).

Do not fully tighten the Screws.

Step 3

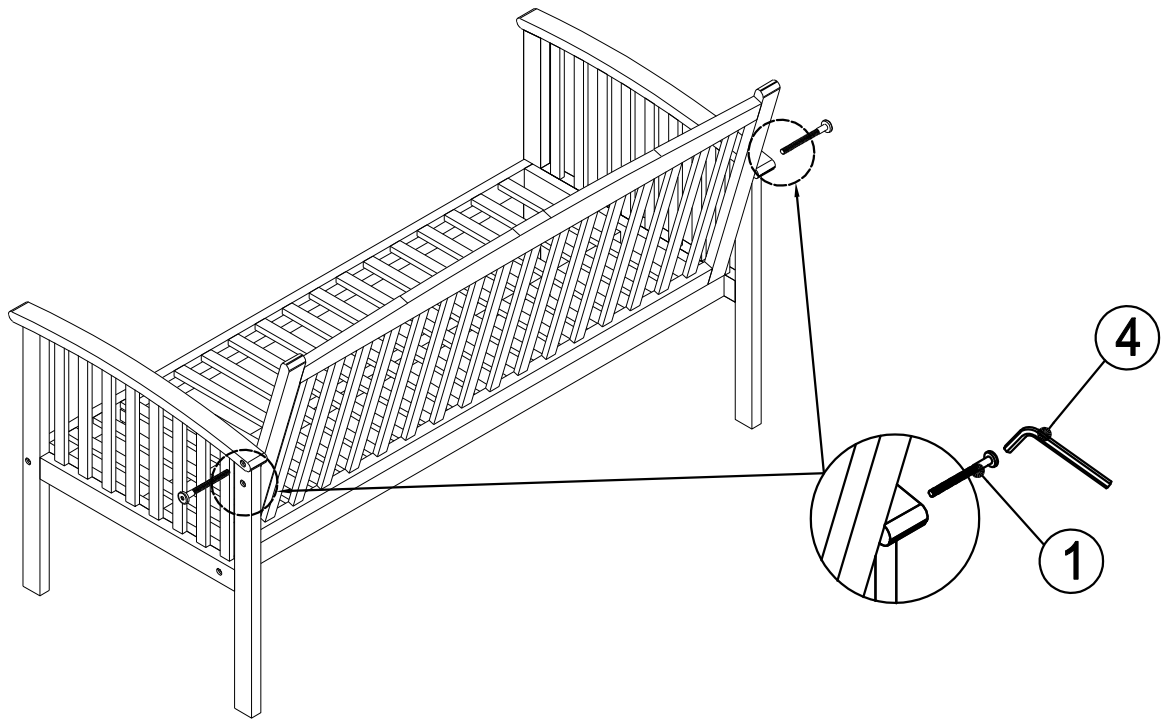

Use Bolt (1) and Allen Wrench (4) to affix the top of the Backrest to the Armrests on both sides as shown.

Do not fully tighten the Bolts

Step 4

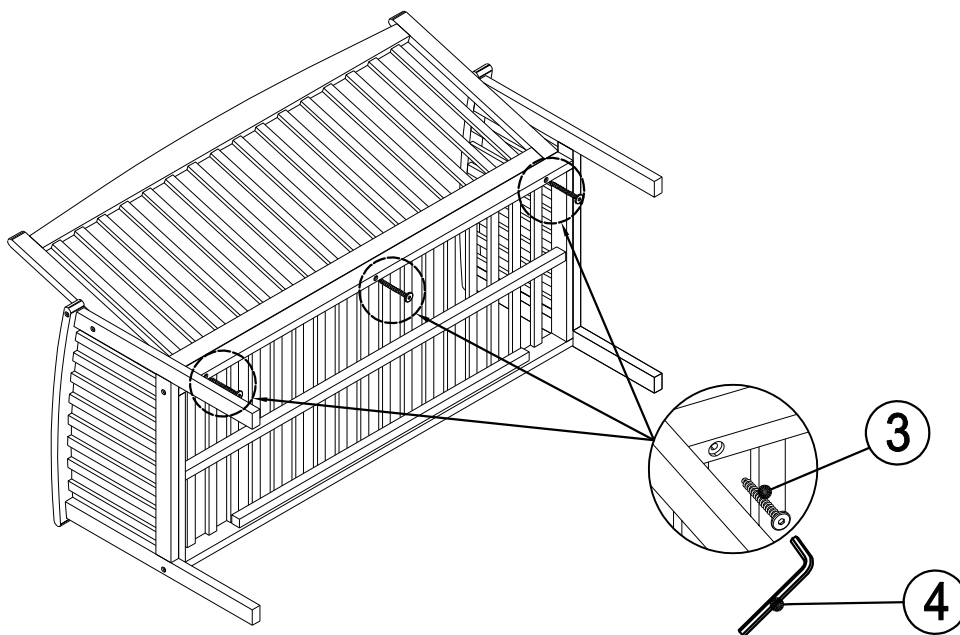

Use Screw (3) and Allen Wrench (4) to attach Backrest Panel (G) and Seat Panel (H).

Do not fully tighten the Screws.



Turn the Bench right side up.
Inspect it and make sure all parts are adequately connected.
Ensure all bolts and screws are fully locked into position and secured.

Step 4

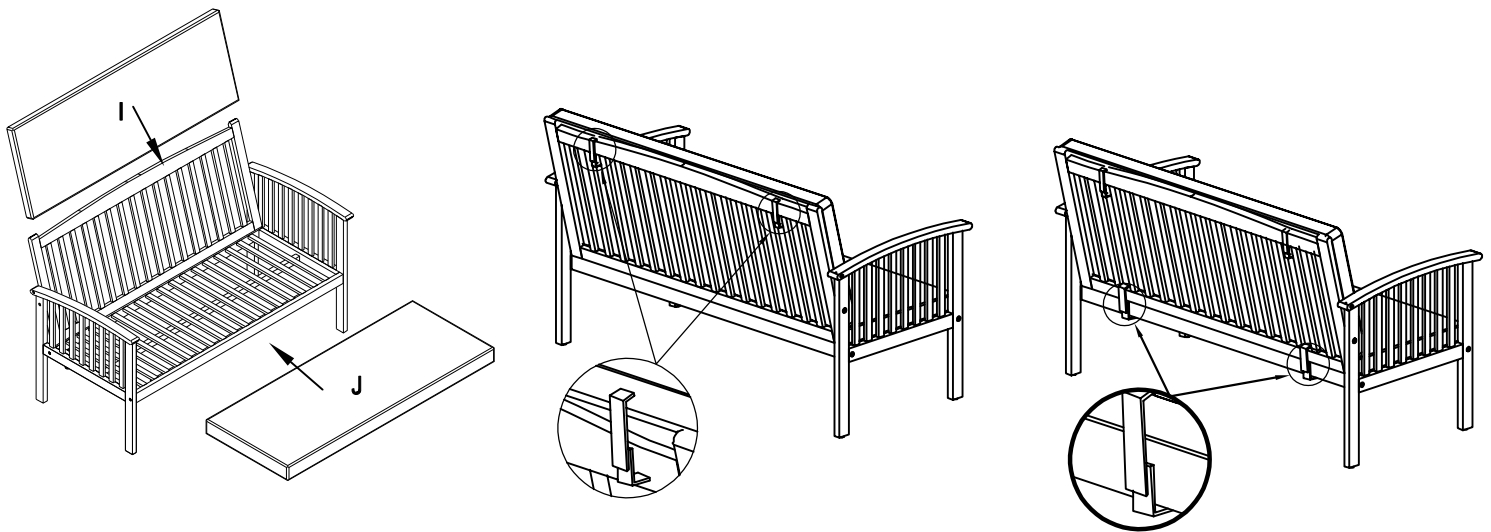

Next, install the Seat Cushion (J) & Back Cushion (I) into the Bench.
Tie the magic tape straps of Seat Cushion (J) and Back Cushions (I) to Seat Panel (H) and Backrest Panel (G) as pictured.
Your Bench is ready for use.
This Bench can only be used on flat, level surface.

Please look into the Seat Panel for hardware packs

COFFEE TABLE

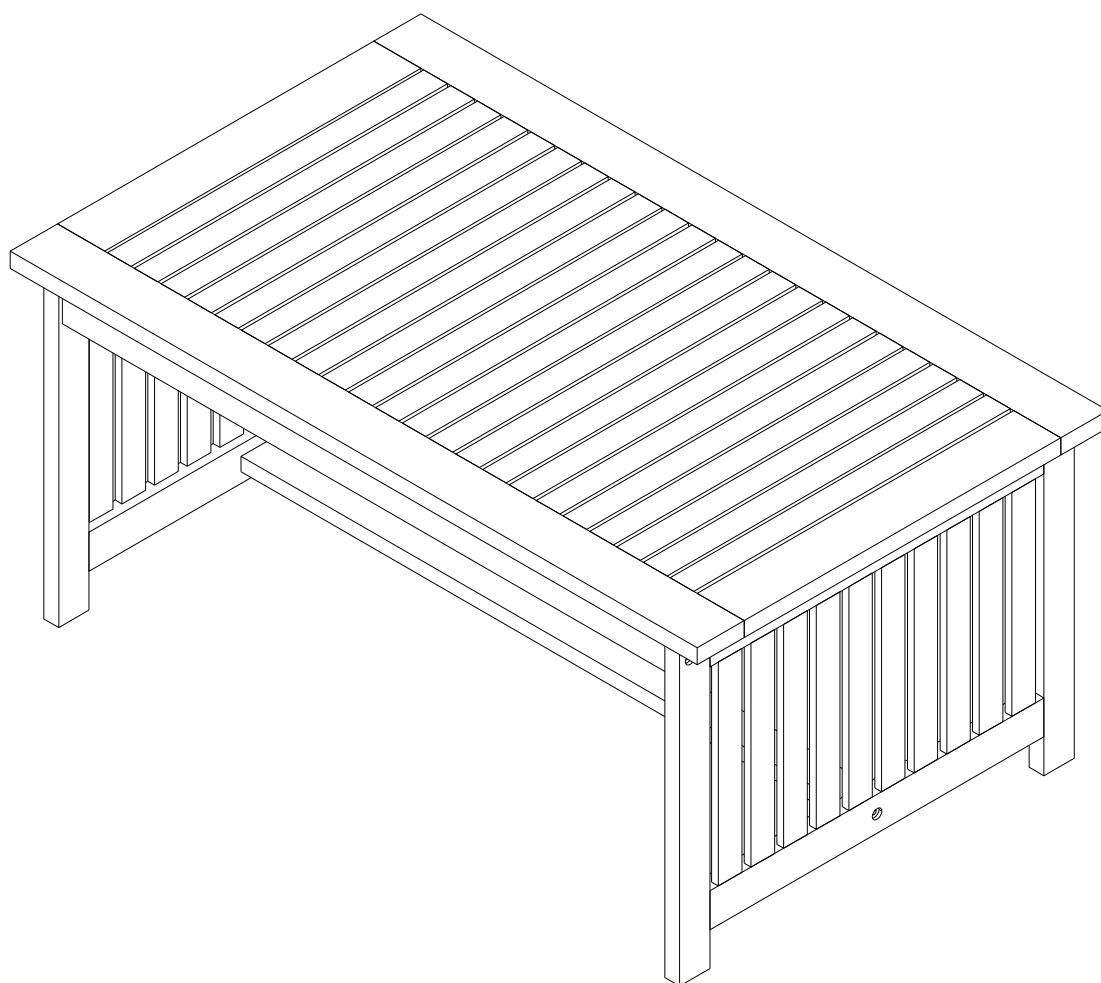

Caution: This Table is NOT a TOY.

Keep your child/children at bay during the assembly process.

Whenever lifting or moving the Table and to prevent damage to the chair, two adults may be needed to execute these actions.

Parts List

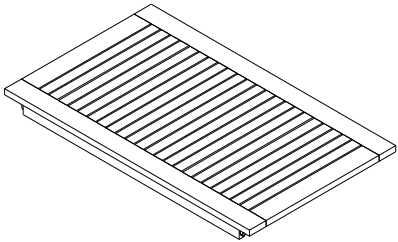
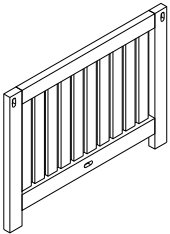
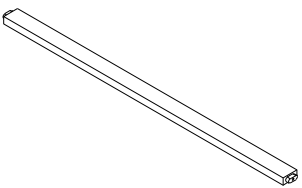
Label	Picture	Description	QTY
K		Table Top	1
L		Leg Panel	2
M		Support Bar	1

Hardware List

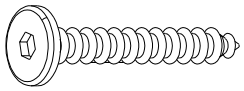
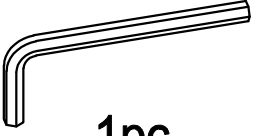
<p>②</p>  <p>6pcs (Extra 1pce) Screw (M7x50)</p>	<p>④</p>  <p>1pc Allen Wrench (M4)</p>	
---	---	--

Assembly Preparation

Before Beginning Assembly

K

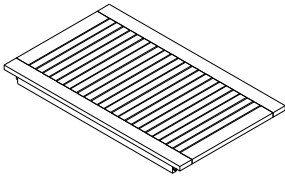

L x2

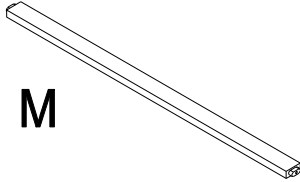
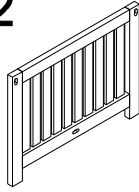

M

②  x 6 + 1

④  x 1



- Read instructions, cover to cover.



- Have 2 adults on hand for assembly.



- Do not assemble on flooring or carpet.

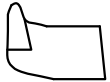

- Assemble on a clean non-marring surface (packing foam).

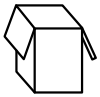

- Save all packaging until finished.

Assembly Preparation

Overview

Table Top (K)

Leg Panel (L)

Support Bar (M)

Leg Panel (L)

FRONT VIEW

This Table has multiple parts and may require up to some 30 minutes to assemble. To give you an overview of the Table, the above picture is to help you put the various parts into perspective. Please read through the instructions here below to familiarise the parts and steps before assembly.

Step 1

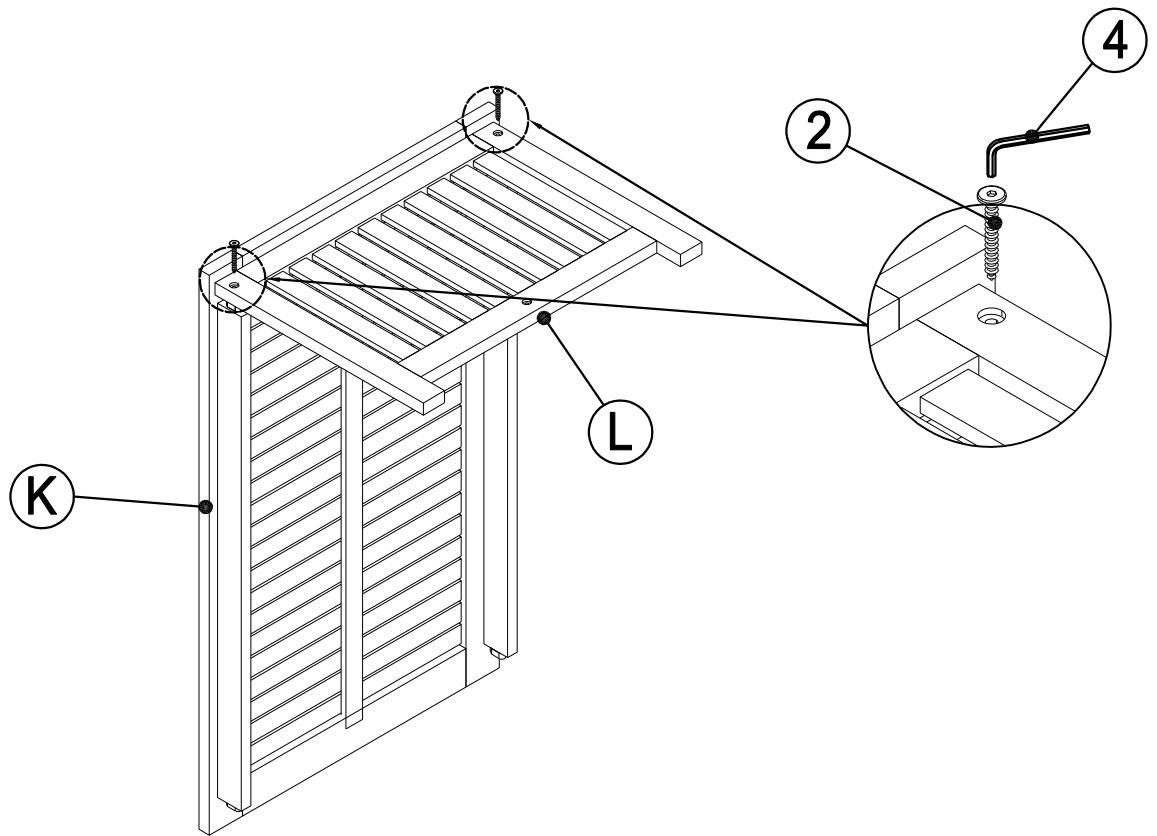

Place all the parts on a clean, non-marring surface.

Attach Leg Panel (L) together Table Top (K)

Lock in the mounting position, using screws(2), screws (3) and Allen Wrench (4).

Do not fully tighten the Screws.

Step 2

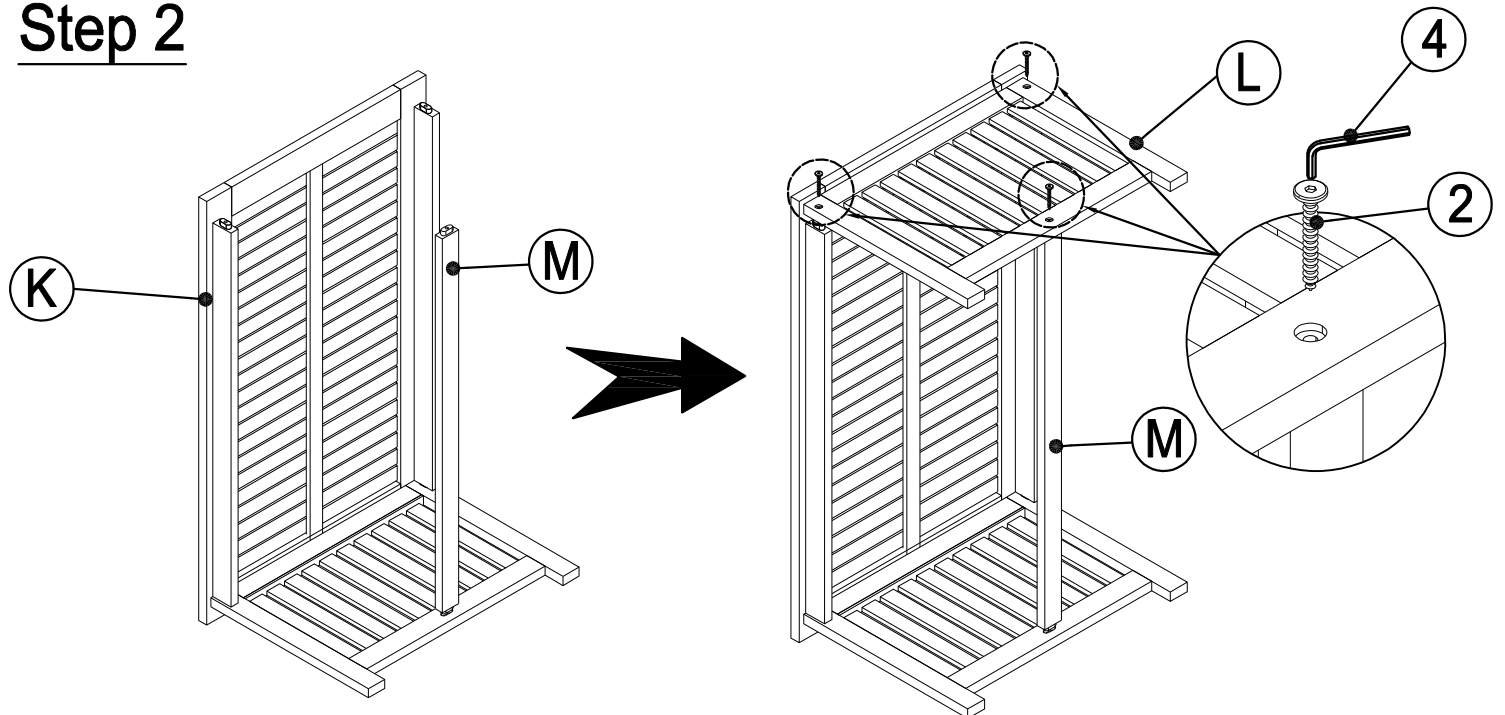

You will now have the Leg Panel (L) and Table Top (K)

Insert the Leg Panel (L) and Support Bar (M)

Lock in the mounting position, using Screw(2), and Allen Wrench (4).

Do not fully tighten the Screw.

Step 3

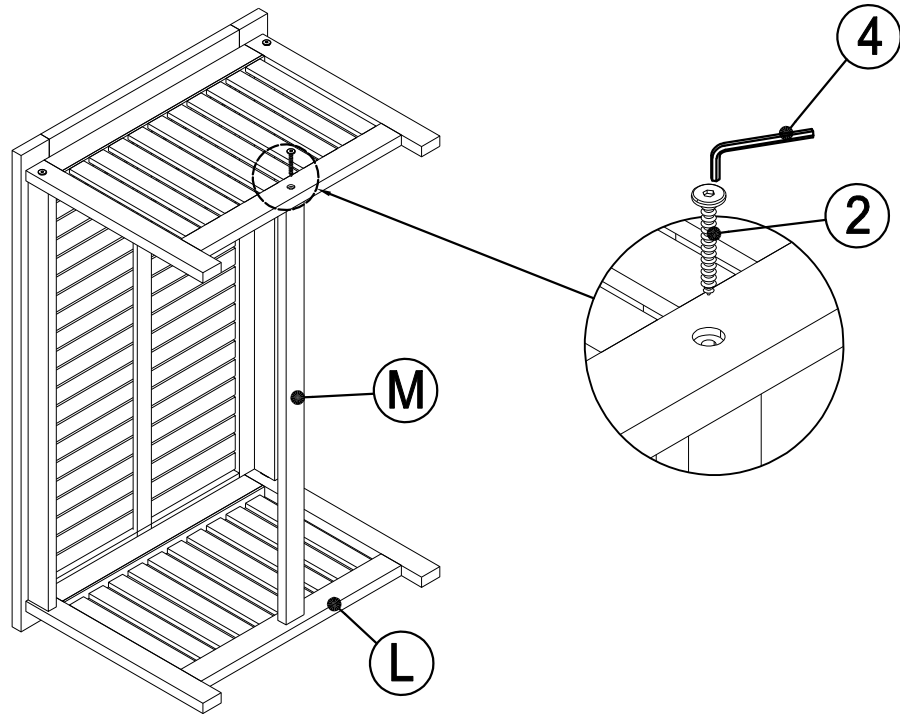

You will now rotation the table 90°

Lock in the mounting position, using Screw(2), and Allen Wrench (4) for Support Bar (M)
Do not fully tighten the Screw.

Step 4

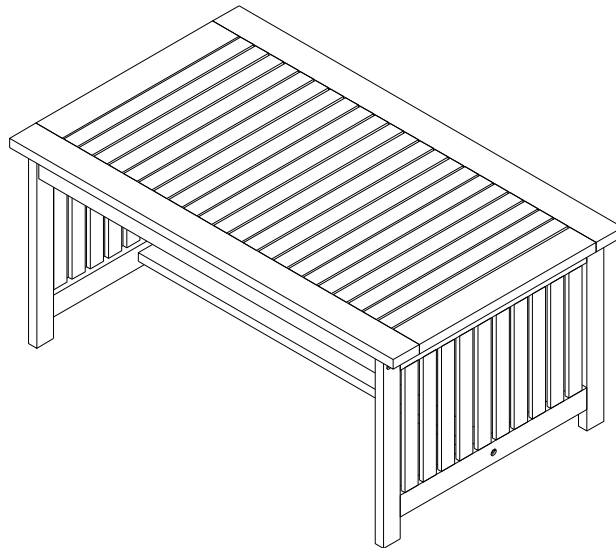

Inspect it and make sure all parts are adequately connected.

In a sequential manner, ensure all screws are fully locked into position and secured.

The Coffee Table is ready to be used.

CAUTION : When tightening these screws, tighten sequentially.

DO NOT tighten any screw fully and then towards the next one.

This would cause the frame to warp.

If there is still wobbles, loosen the screws and execute this same drop tests.

IF TABLE IS NOT STABLE , IT COULD LEAD TO DAMAGING THE PRODUCT.