

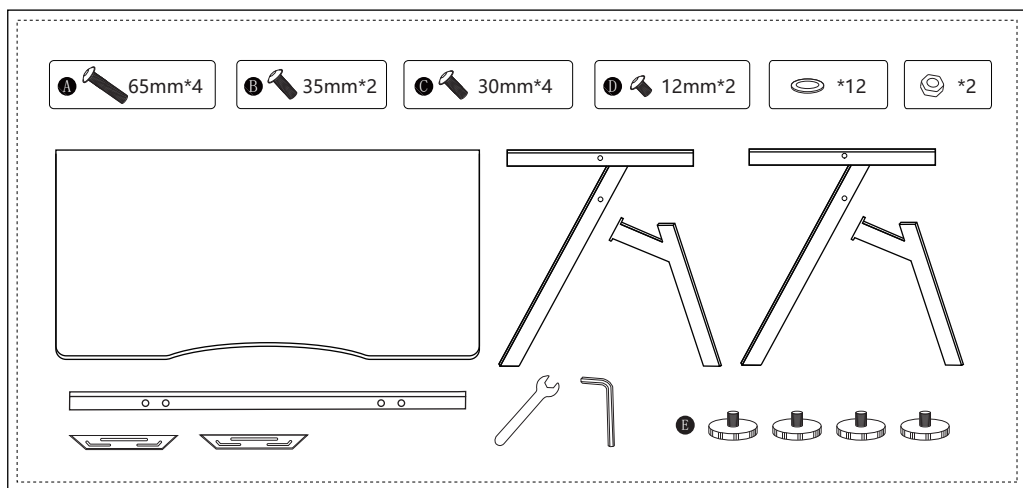

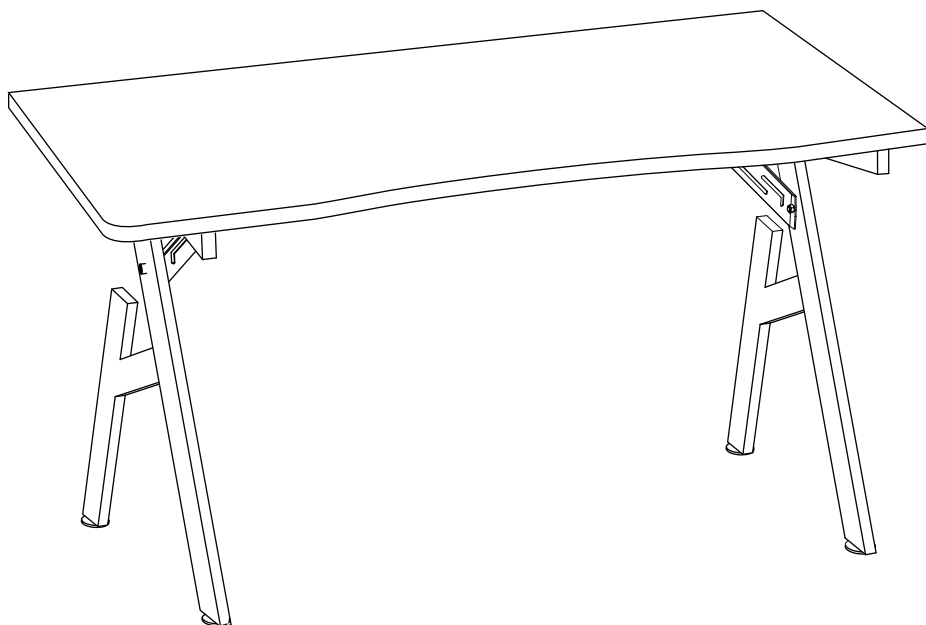

Installation & Assembly



-   30mm*2
-  *2

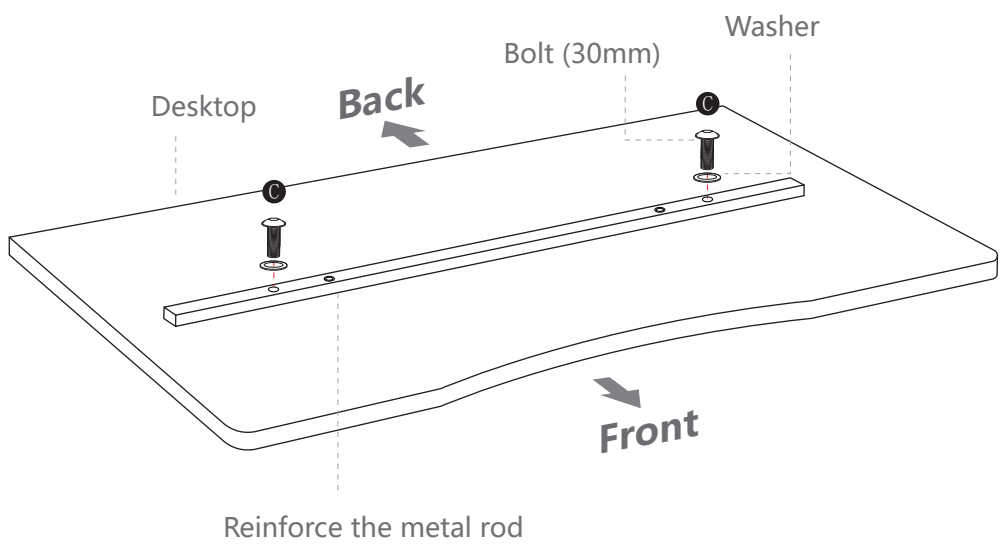

Attach the metal rod to the top desktop.

B  35mm*2

 *2

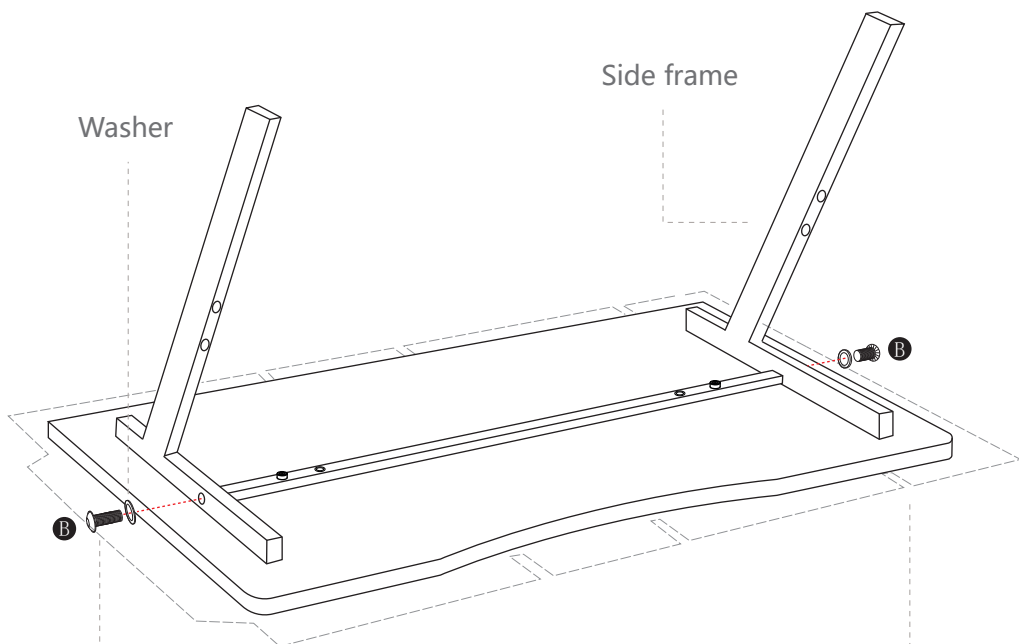

Bolt (35mm)

※ Note: Please leave it a bit loose.

You can lay the packaging box flat on the ground to use as padding, preventing direct contact between the desktop and the floor, which could cause wear.

C  30mm*2

D  12mm*2

 *4

 *2

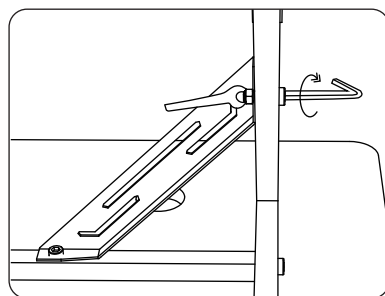
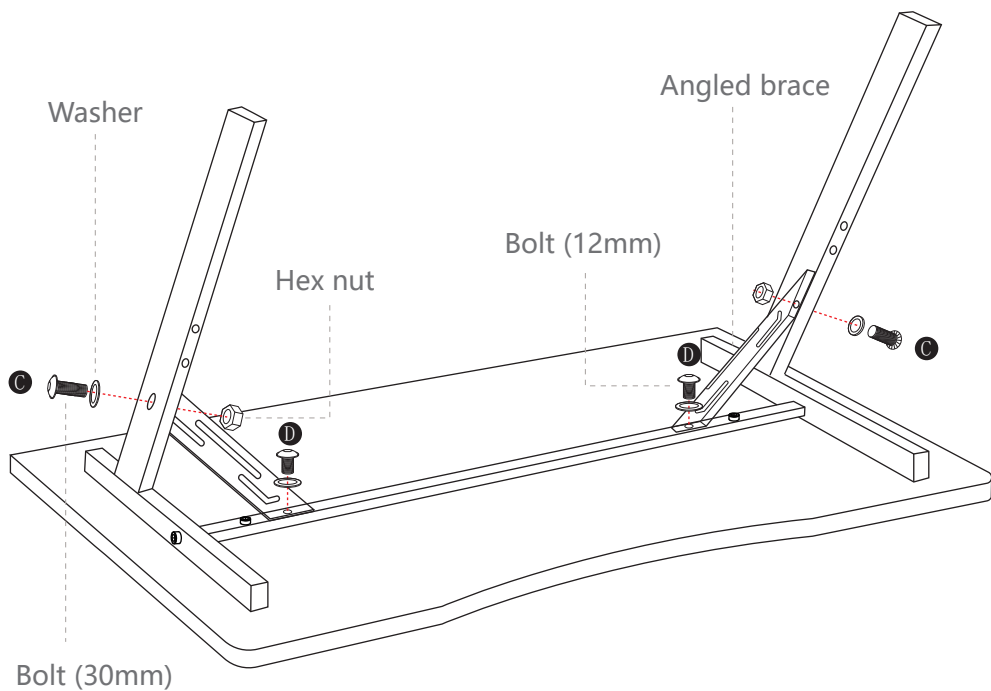

⚠ Please do not tighten the screws too much during assembly. Be especially careful not to fully tighten all the screws until they are all in place.

A



65mm*4



*4

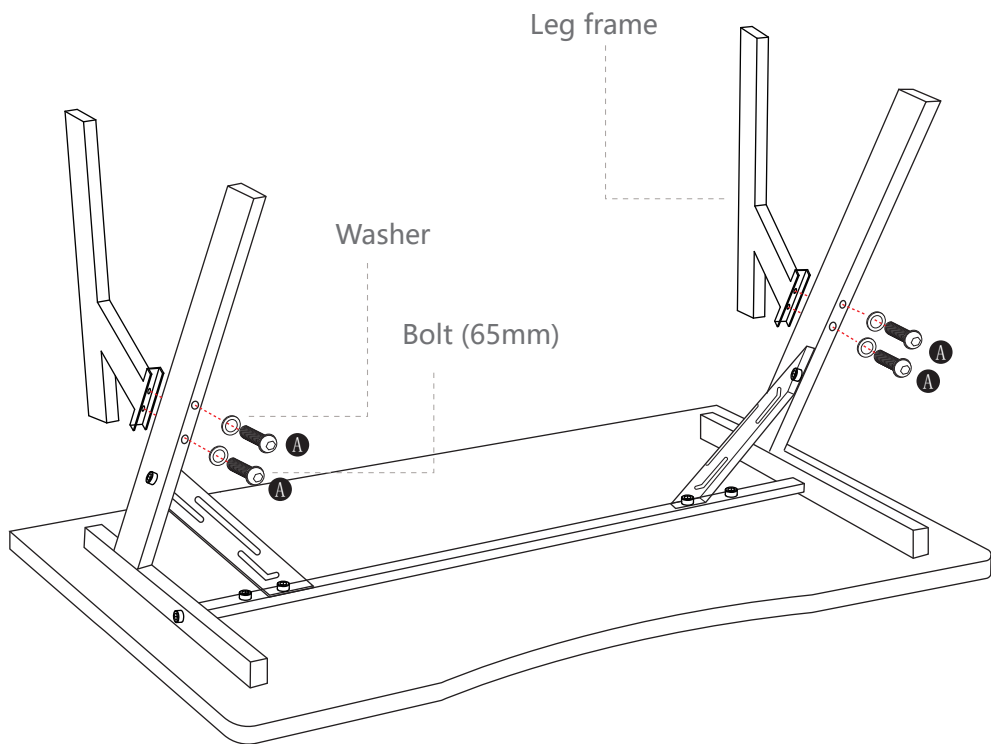

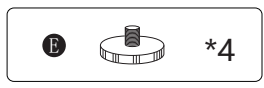

Foot pad

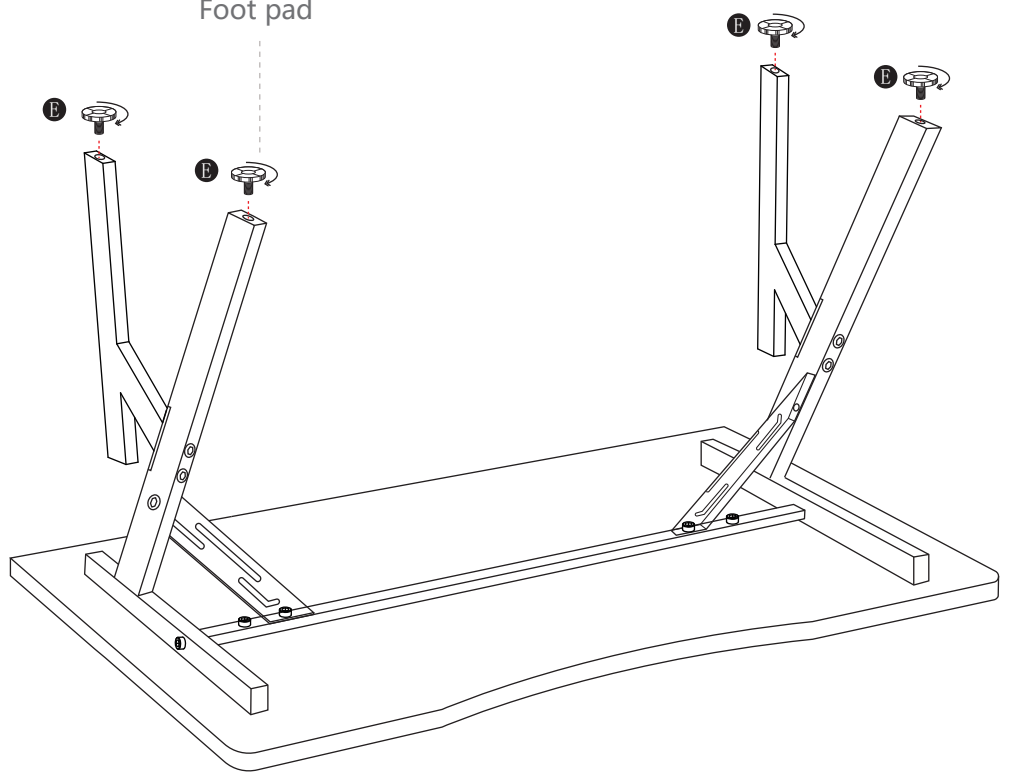

Install the foot pads.

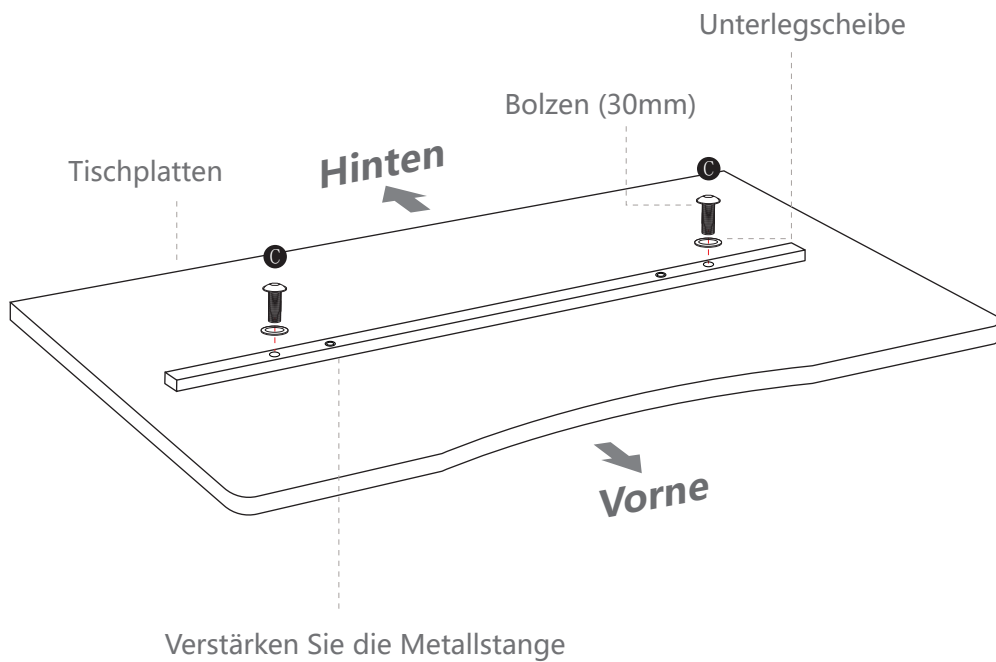

Befestigen Sie die Metallstange an der Tischplatten.

  35mm*2

 *2

Unterlegscheibe

Seitlicher Rahmen

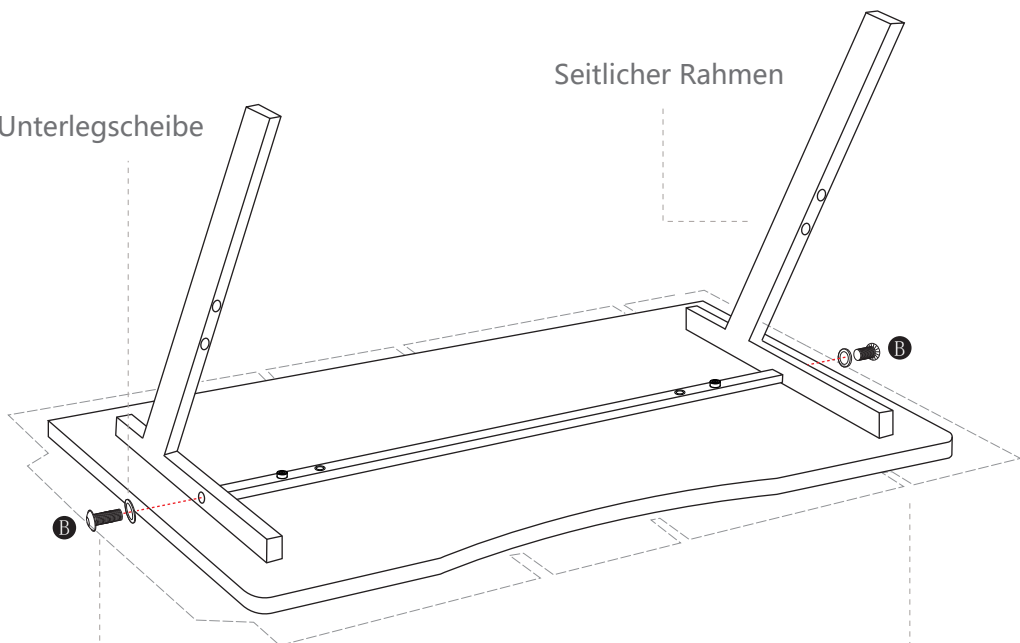

Bolzen (35mm)

※ Bitte lassen Sie es ein wenig locker.

Sie können den Karton flach auf den Boden legen und als Unterlage verwenden, um zu verhindern, dass die Tischplatte direkt mit dem Boden in Kontakt kommt und dadurch beschädigt wird.

C  30mm*2

D  12mm*2

 *4

 *2

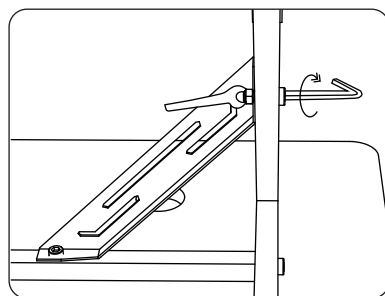
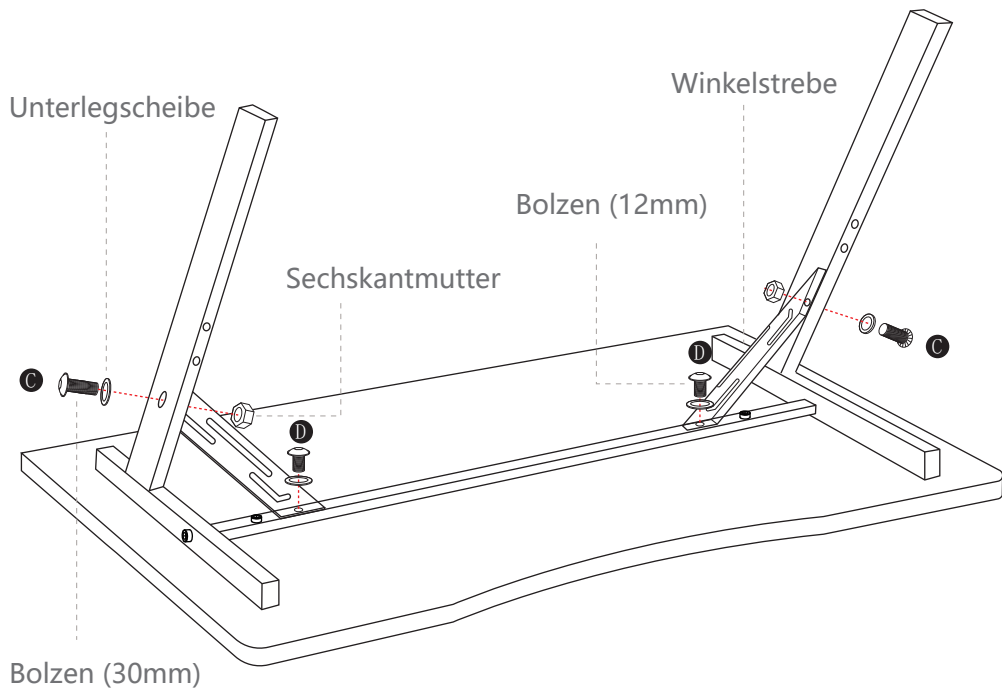

! Bitte ziehen Sie die Schrauben während der Montage nicht zu fest an. Achten Sie besonders darauf, alle Schrauben nicht festzuziehen, bis sie an ihrem Platz sind.

A



65mm*4



*4

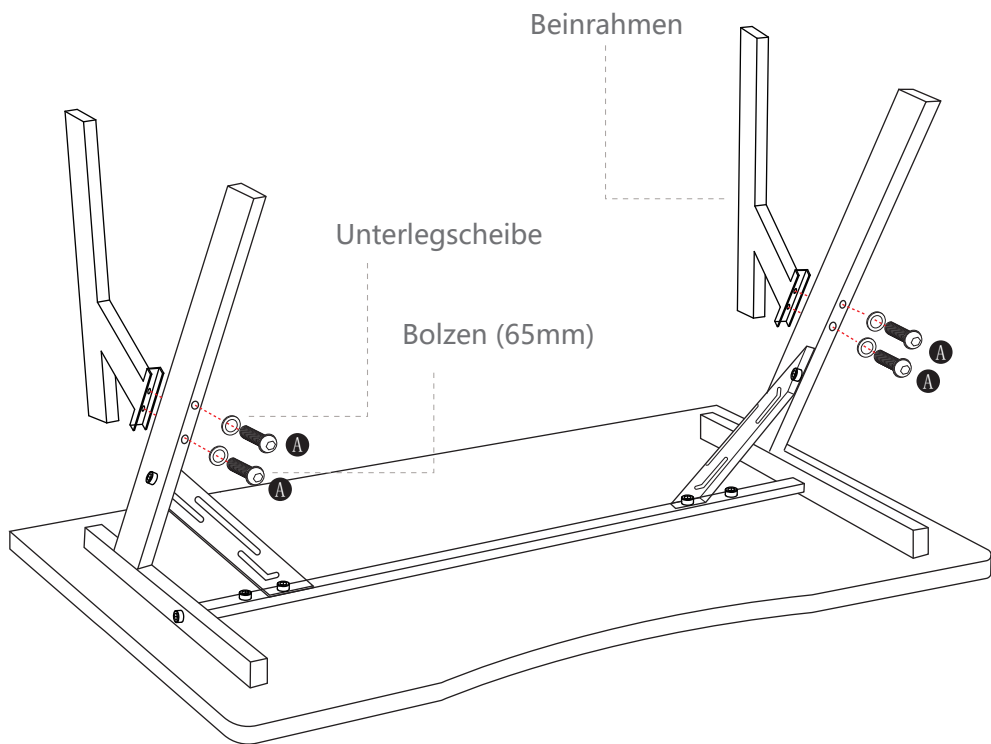

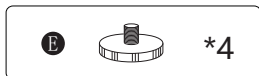

Füße

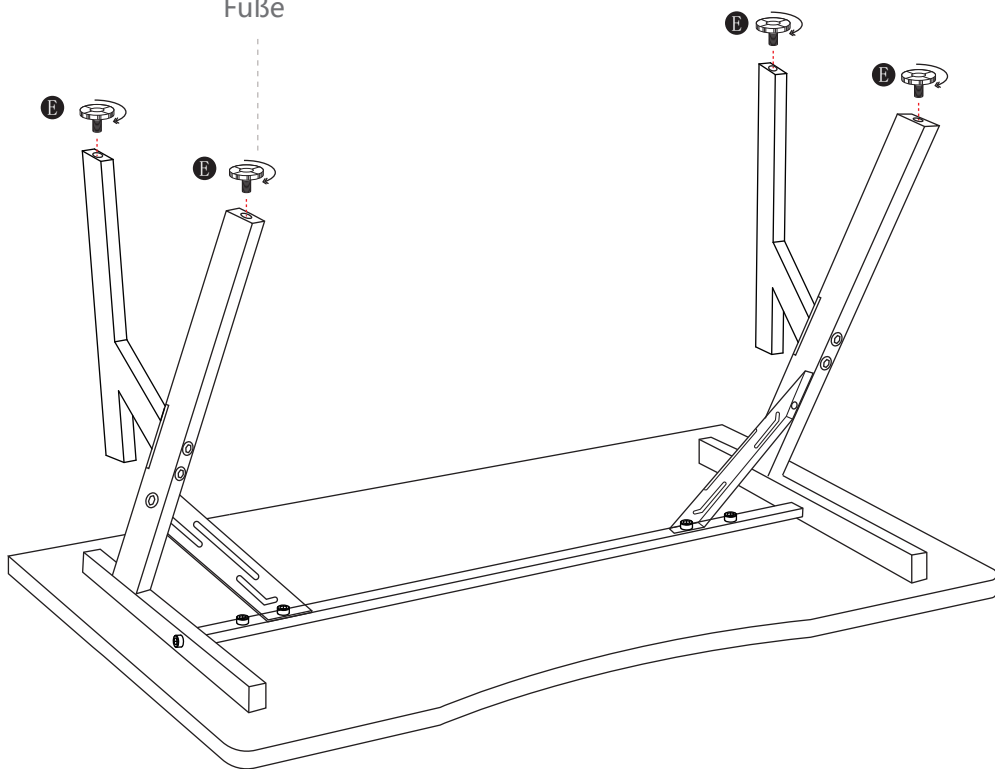

Montieren Sie die Füße.

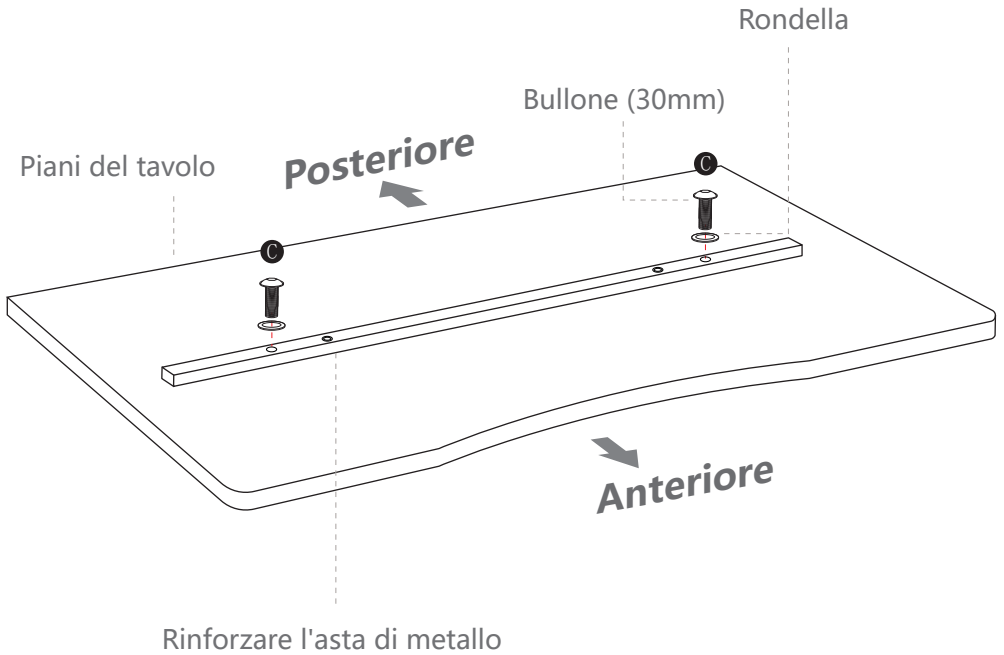
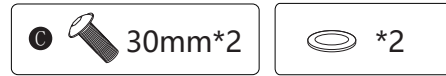

Fissare l'asta di metallo alla piani del tavolo.

B  35mm*2

 *2

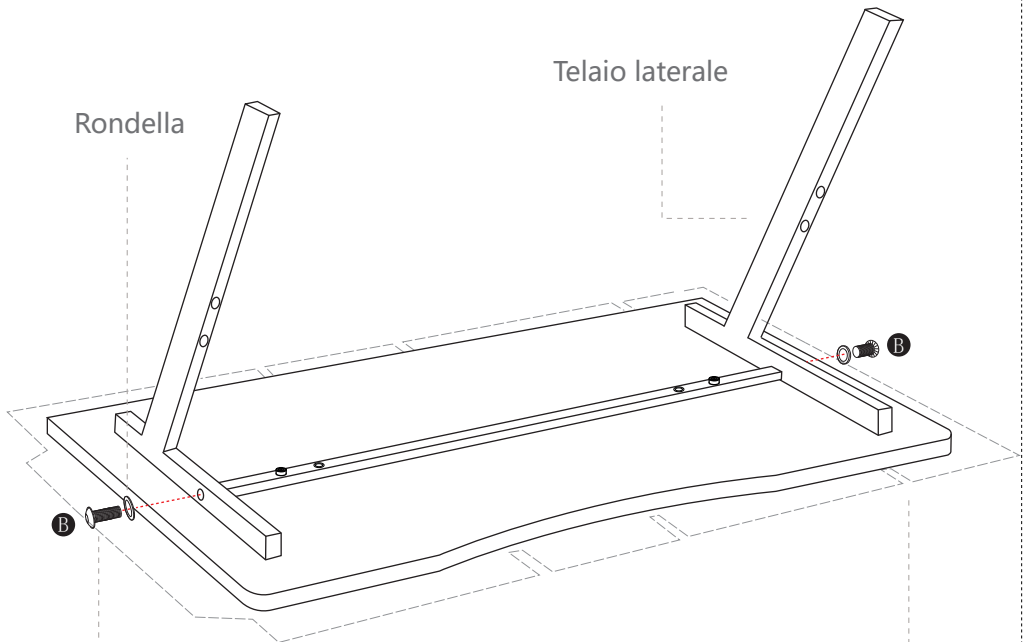

Bullone (35mm)

※ Per favore, lascialo un po' allentato.

Può stendere il cartone dell'imballaggio sul pavimento e usarlo come tappetino per evitare che il piano del tavolo entri in contatto diretto con il pavimento e si danneggi.

C  30mm*2

D  12mm*2

 *4

 *2

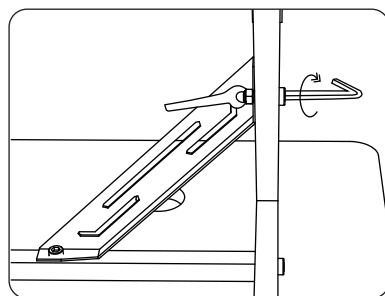
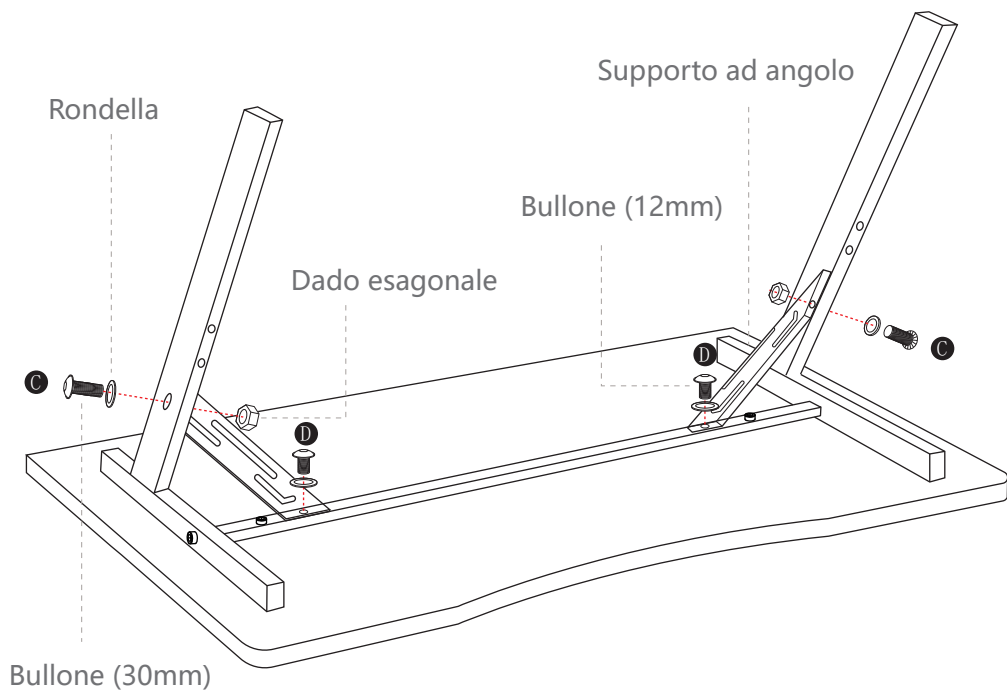

! Si prega di non stringere troppo le viti durante il montaggio.
Prestare particolare attenzione a non stringere completamente tutte le viti finché non sono tutte in posizione.

 65mm*4

 *4

Telaio delle gambe

Rondella

Bullone (65mm)

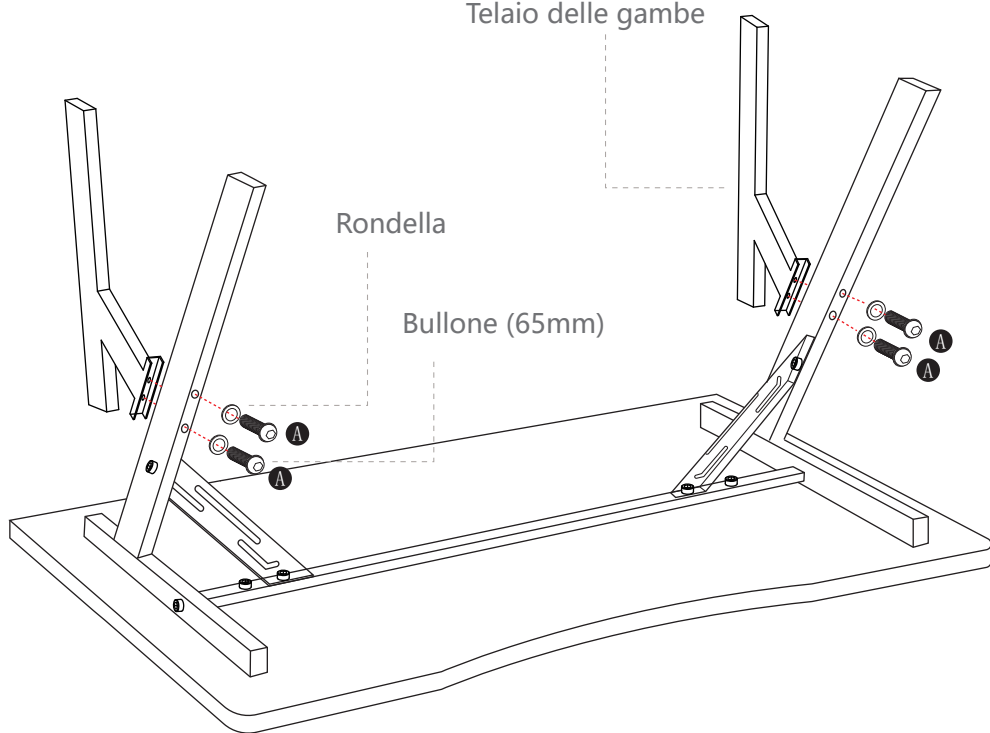

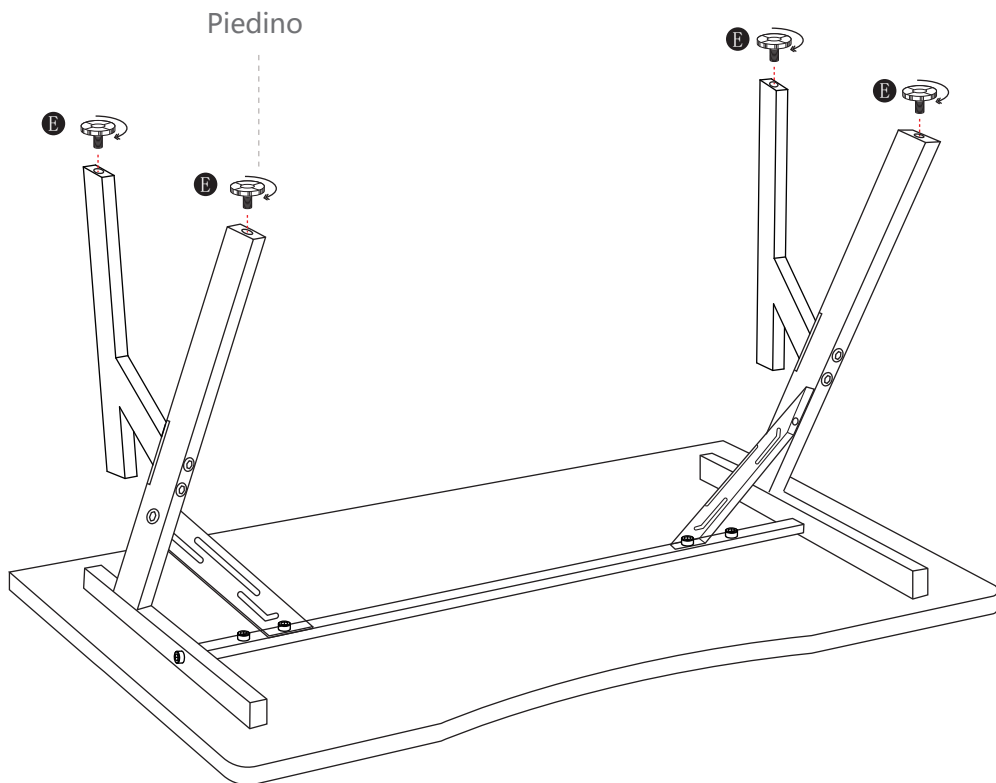
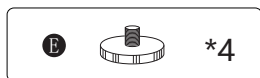

Installare i piedini.

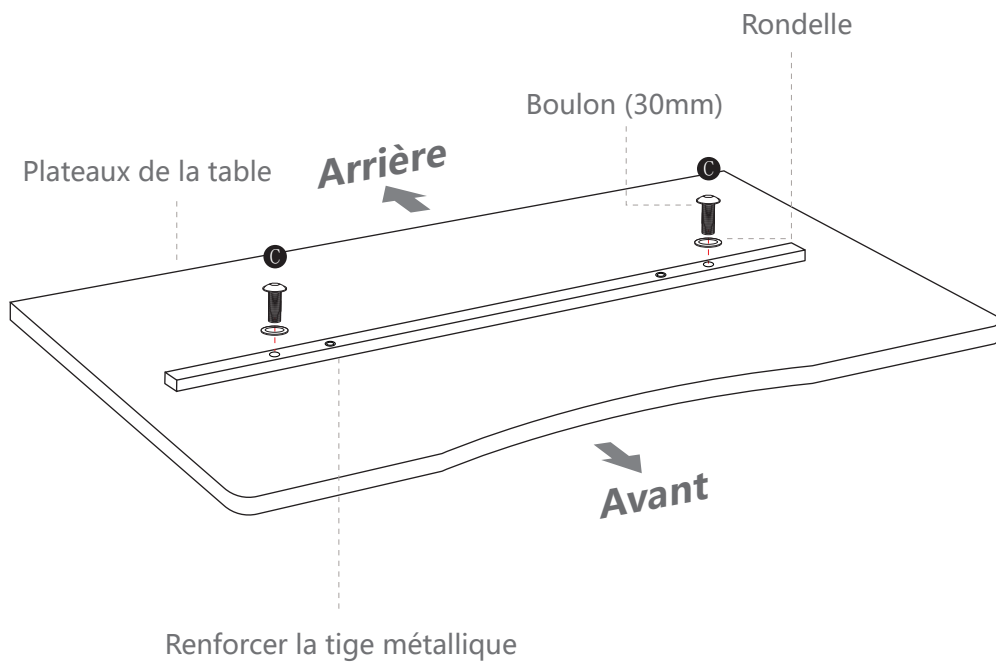

Fixer la tige métallique aux plateaux de la table.

B  35mm*2

 *2

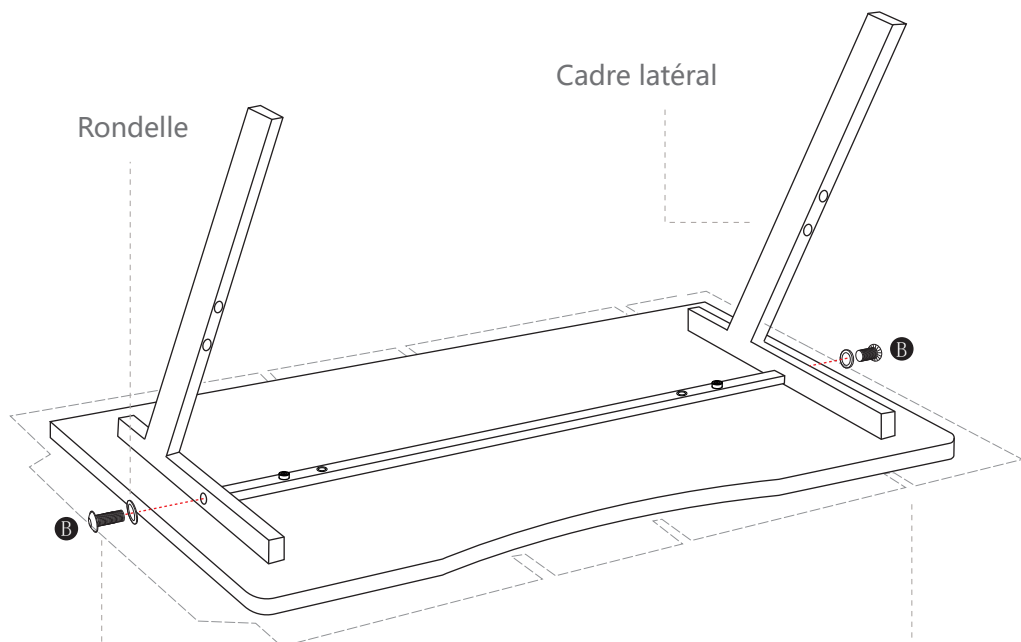

Boulon (35mm)

※ Veuillez le laisser un peu lâche.

Vous pouvez étaler le carton d'emballage sur le sol et l'utiliser comme tapis pour éviter que le plateau de la table n'entre en contact direct avec le sol et ne s'abîme.

C  30mm*2

D  12mm*2

 *4

 *2

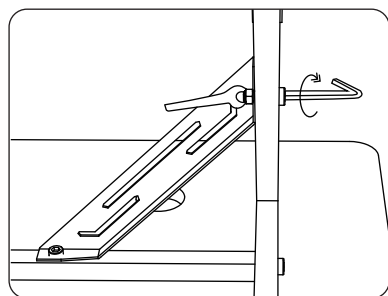
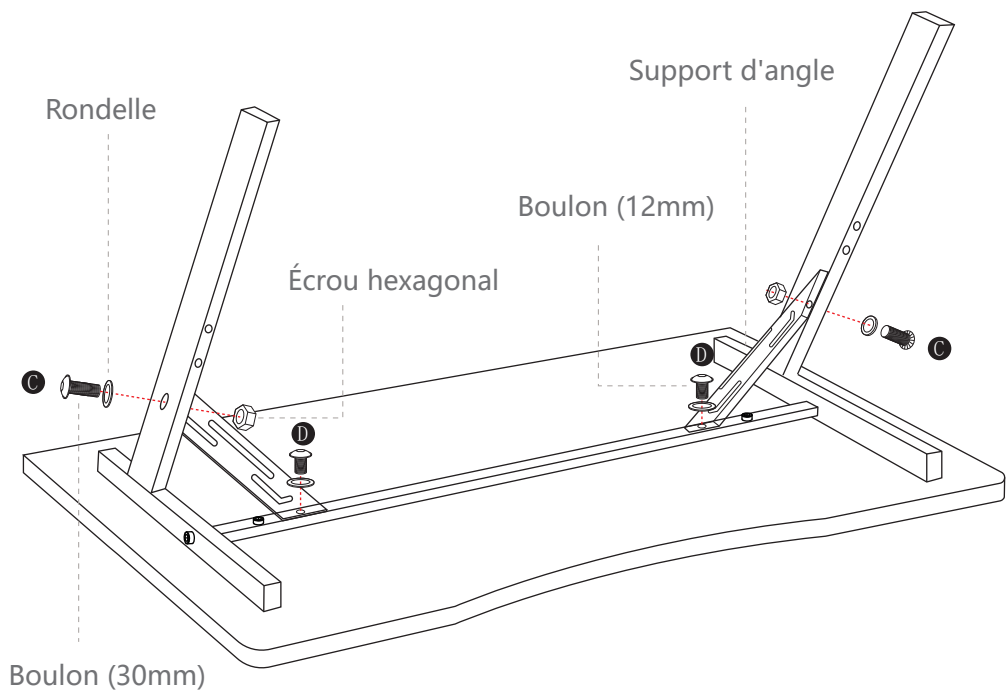

⚠ Veuillez ne pas serrer trop les vis pendant l'assemblage.
Faites particulièrement attention à ne pas serrer complètement toutes les vis tant qu'elles ne sont pas toutes en place.



Cadre des jambes

Rondelle

Boulon (65mm)

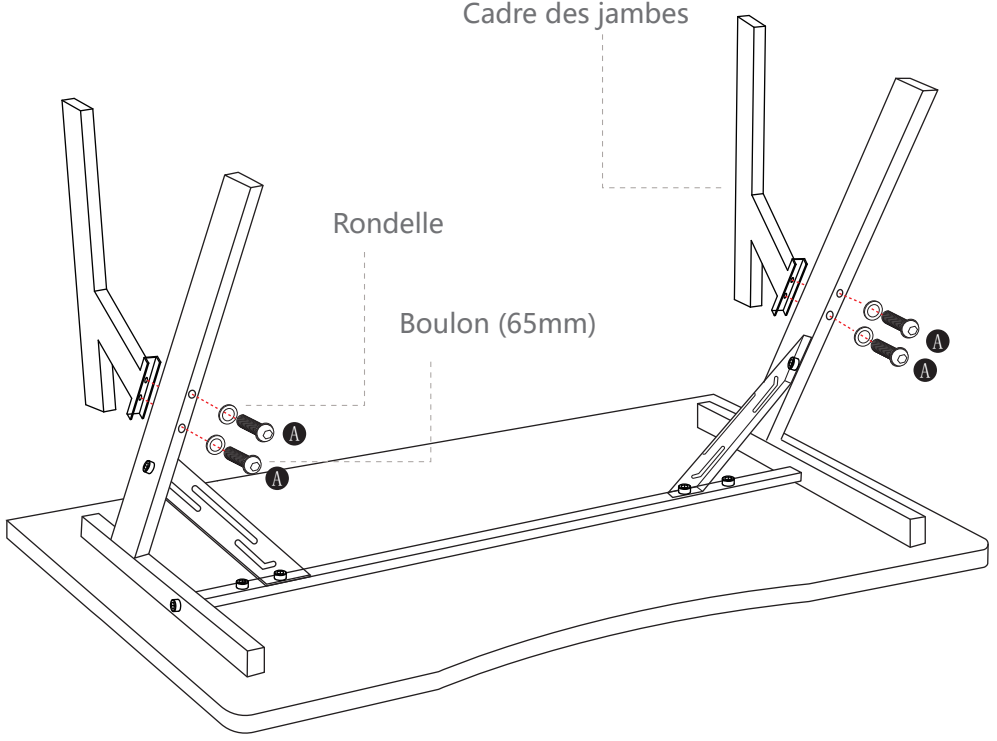

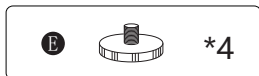

Pieds

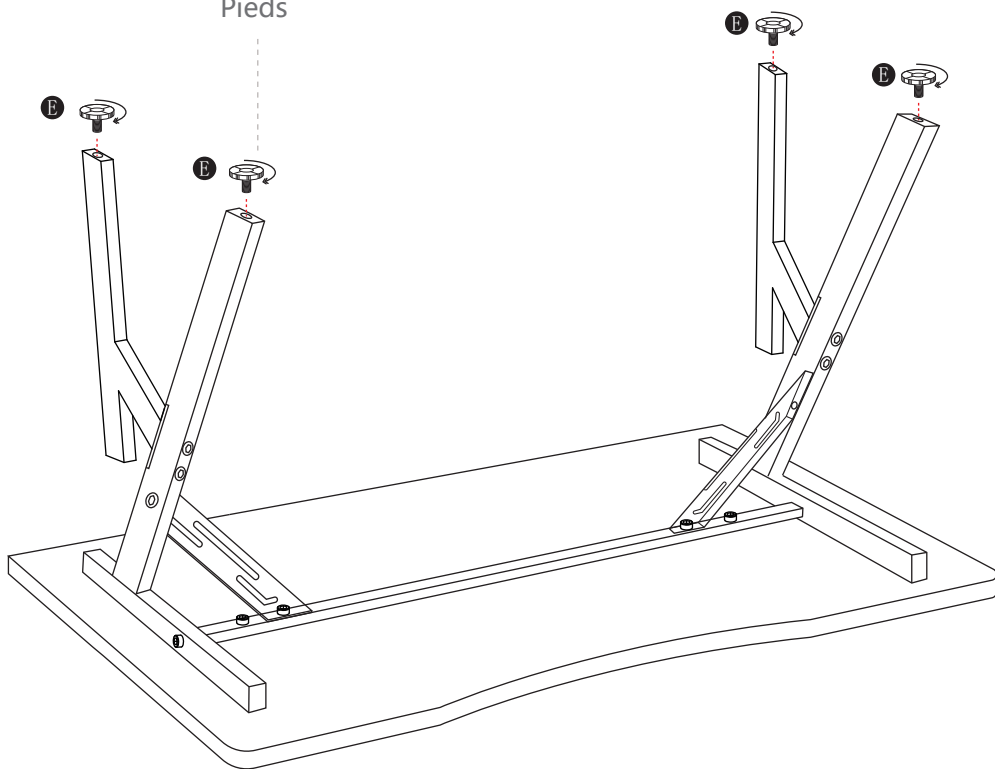

Installer les pieds.

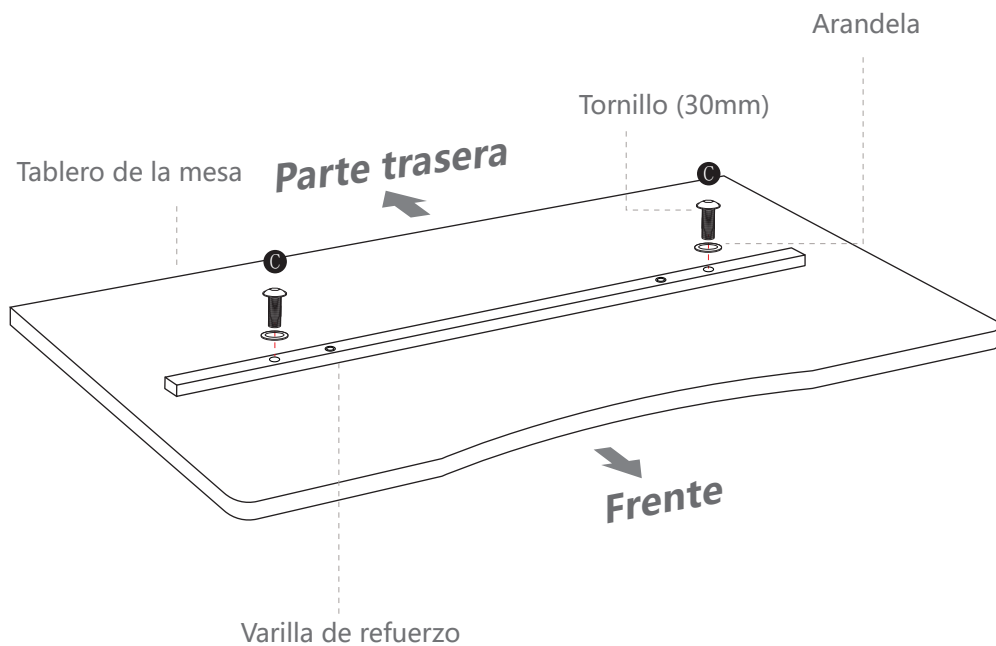
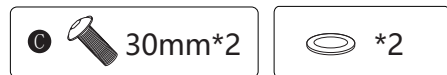

Fije el marco a la tabla utilizando los tornillos

B  35mm*2

 *2

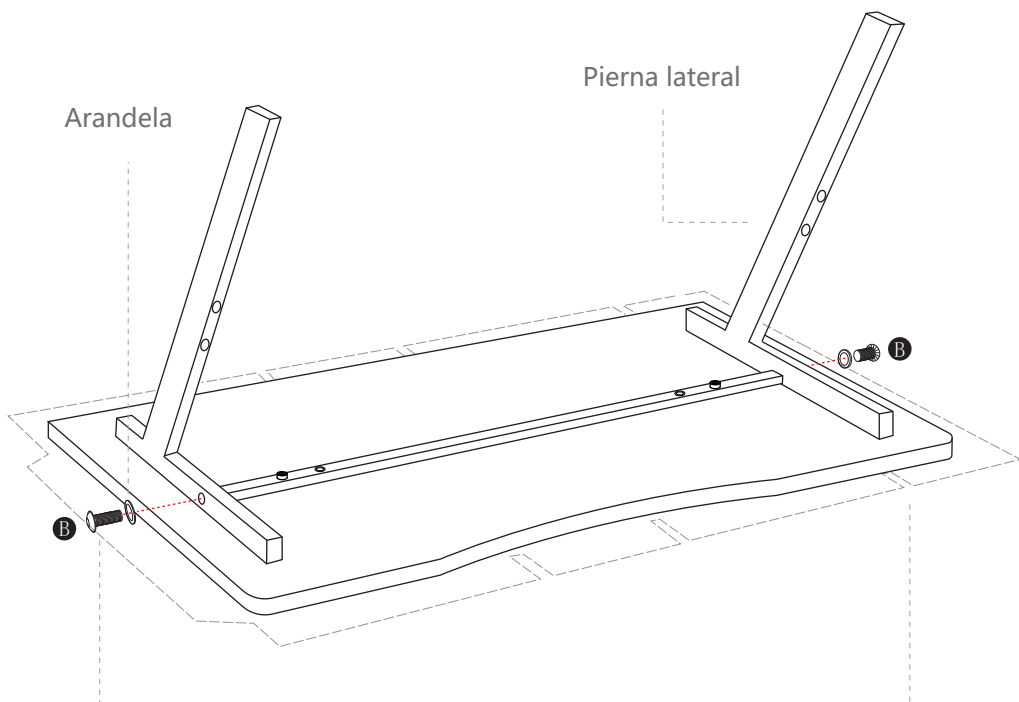

Tornillo (35mm)

※ No lo apriete completamente por ahora

Puede extender la caja de embalaje en el suelo y usarla como acolchado para evitar que la superficie de la mesa entre en contacto directo con el suelo y se dañe.

C  30mm*2

D  12mm*2

 *4

 *2

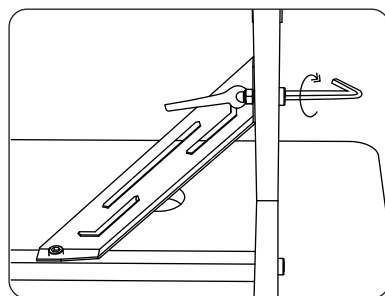
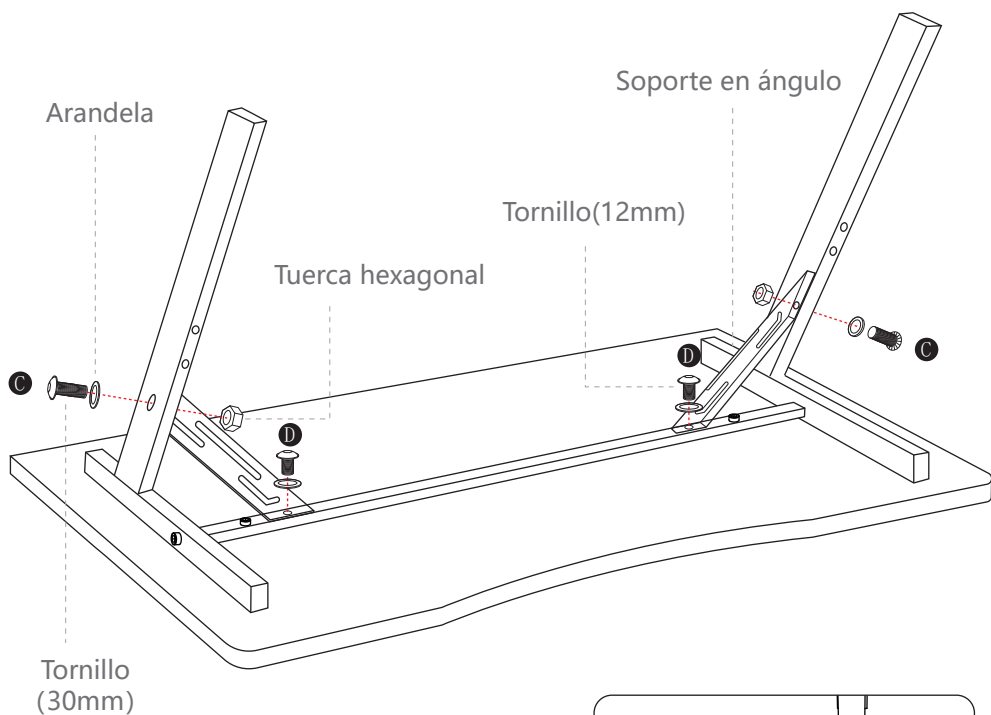

! Por favor, tenga en cuenta que debe apretar cada tornillo solo después de haber fijado todos los tornillos.

A



65mm*4



*4

Soporte de la pierna

Arandela

Tornillo (65mm)

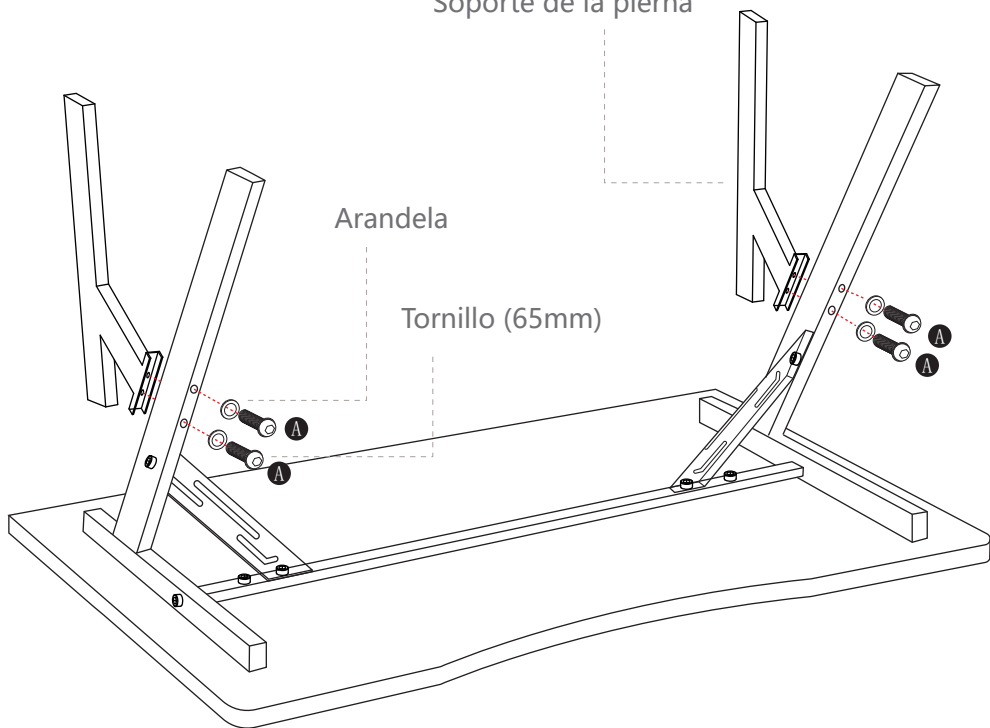

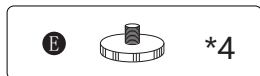

Tapón de pie regulable

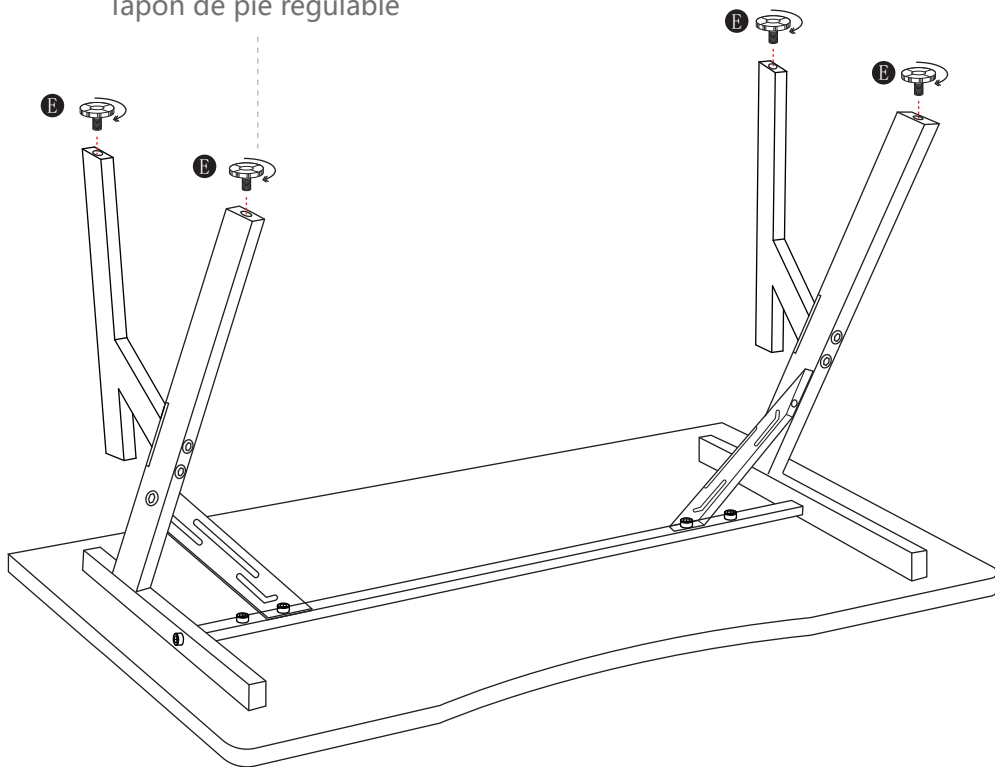

Instale el tapón de pie regulable.

  30mm*2

 *2

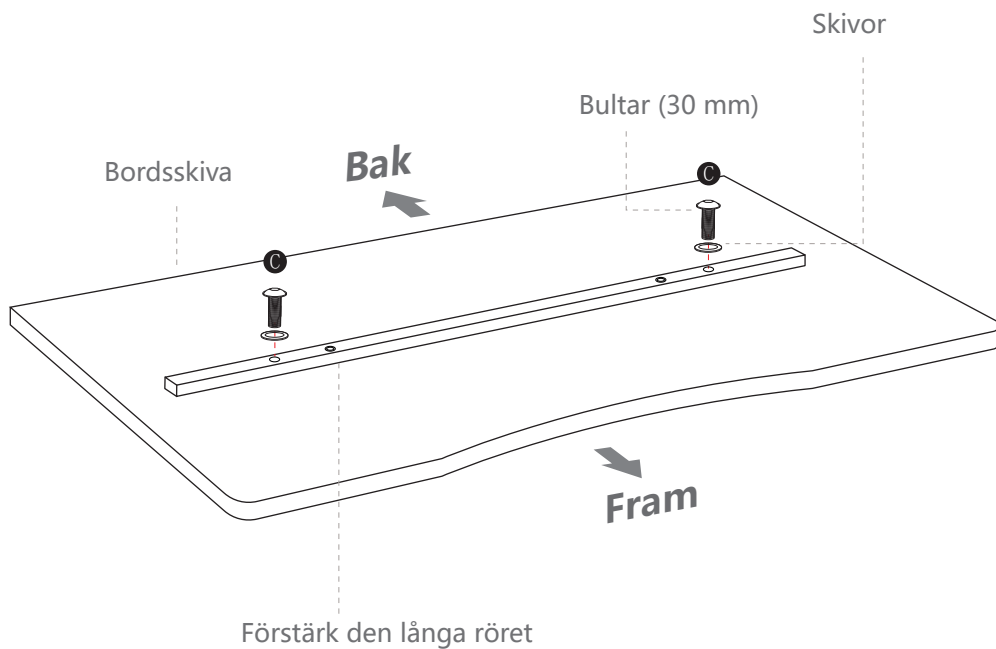

Fäst ramen på bordsskivan.

B  35mm*2

 *2

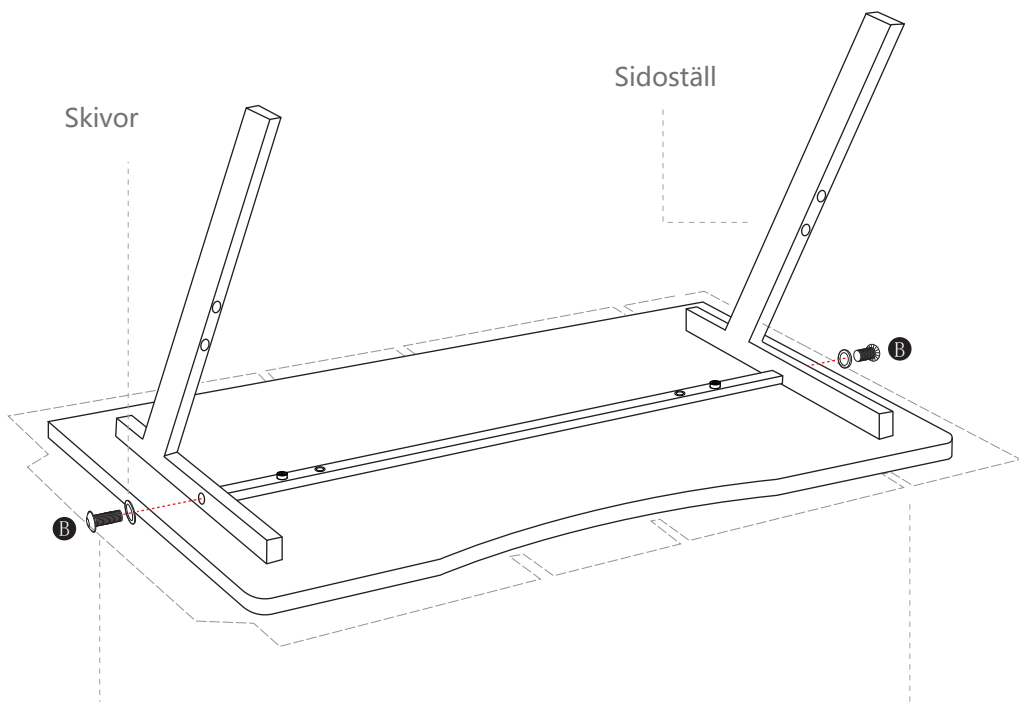

Bultar (35 mm)

※ Jag kommer att hålla det löst

Du kan lägga ut förpackningslådan på golvet och använda den som underlag för att förhindra att bordsskivan kommer i direkt kontakt med golvet och blir skadad.

C  30mm*2

D  12mm*2

 *4

 *2

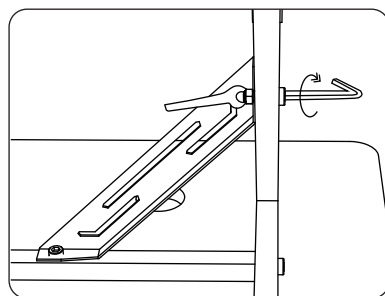
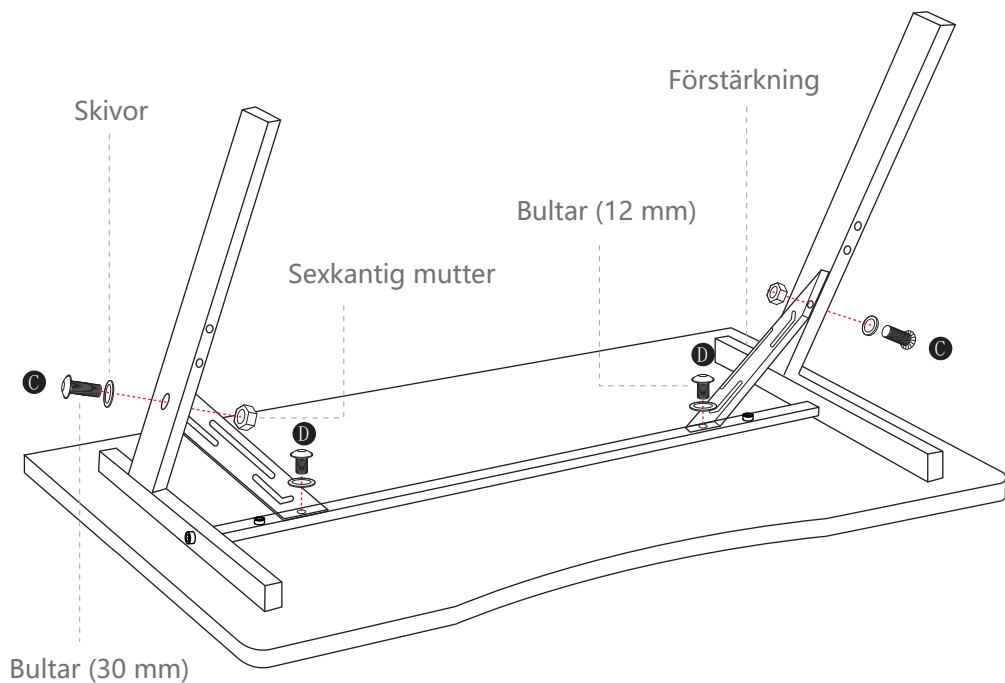

! Var noga med att inte dra åt skruvarna för hårt under monteringen. När alla skruvar är på plats, dra åt dem alla samtidigt.

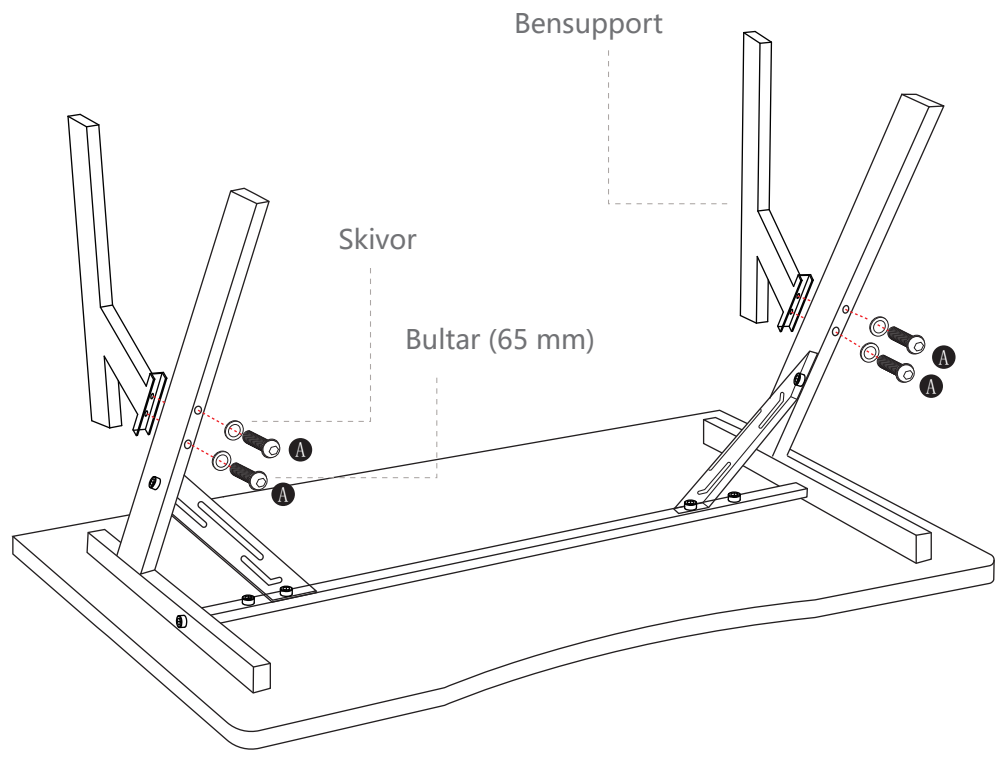

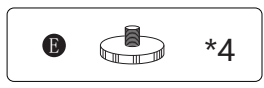

Fötter

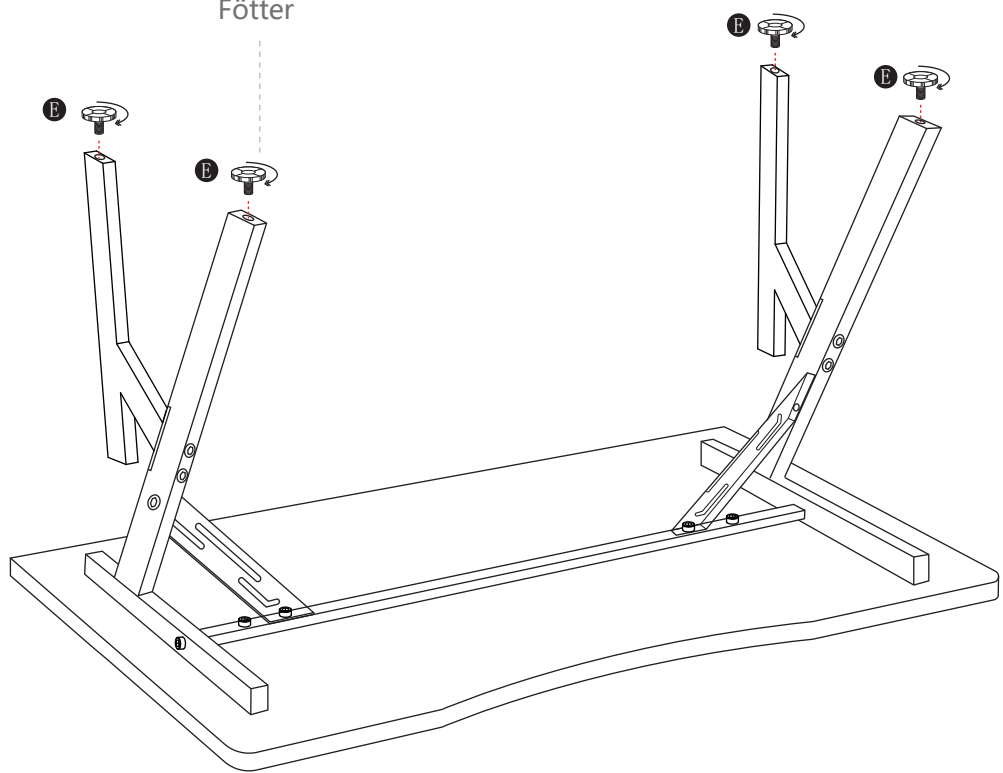

Installera fötter

  30mm*2

 *2

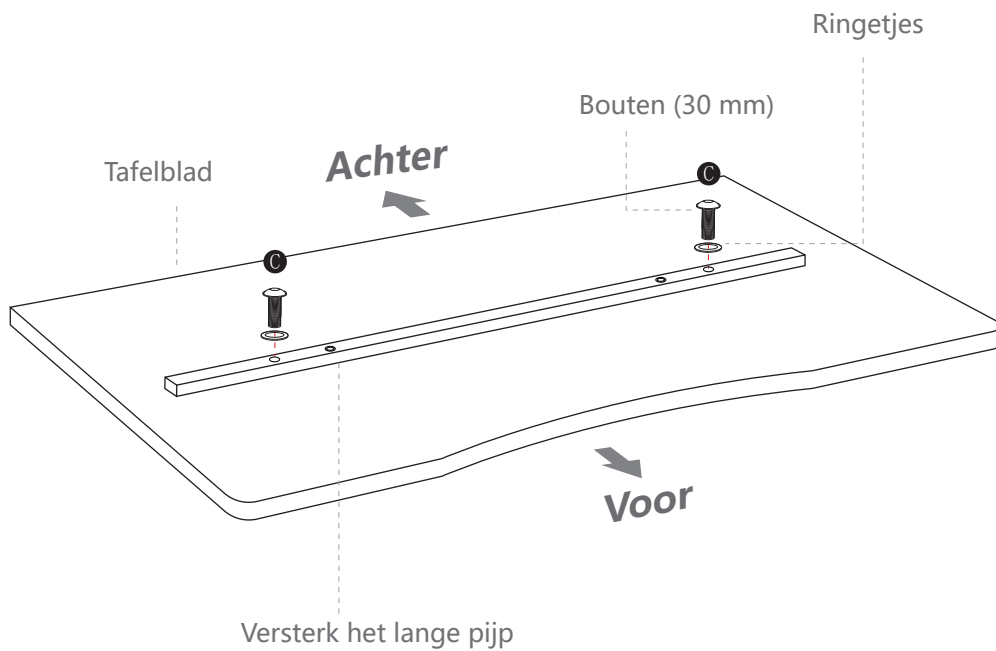

Bevestig het frame aan het tafelblad.

B  35mm*2

 *2

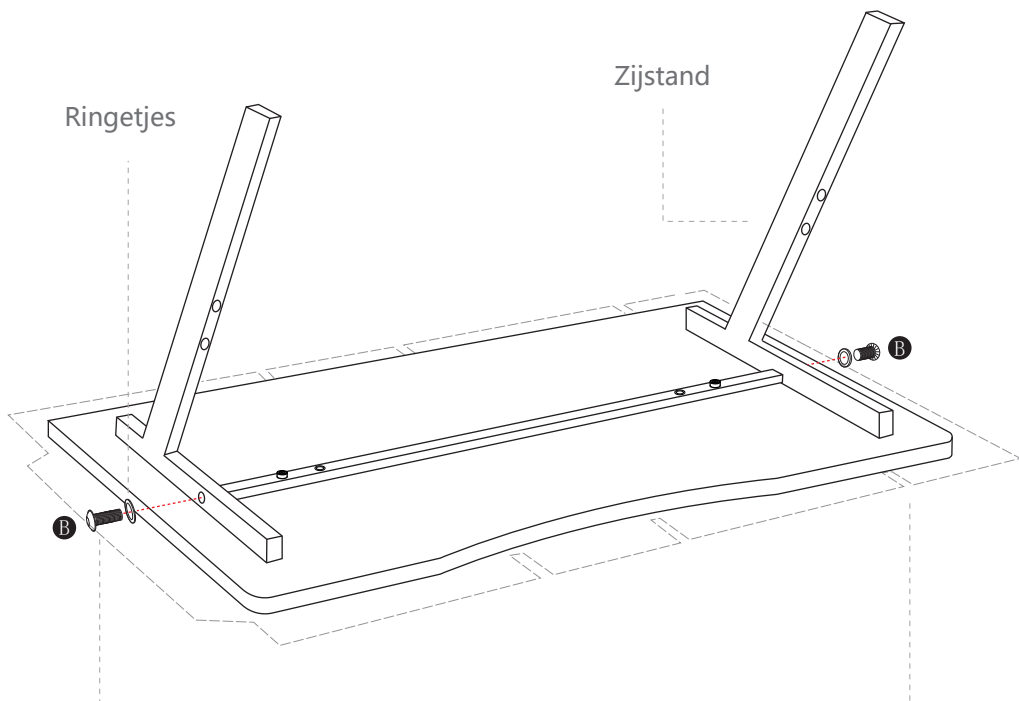



Bouten (35 mm)

※ Ik houd het los

U kunt de verpakkingendoos plat op de vloer leggen en als onderlegger gebruiken om te voorkomen dat het tafelblad direct in contact komt met de vloer en beschadigd raakt.

C  30mm*2

D  12mm*2

 *4

 *2

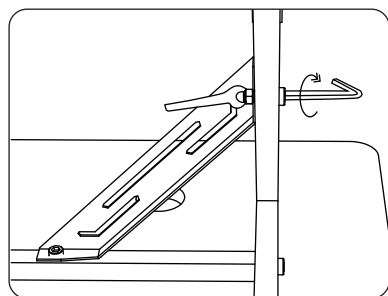
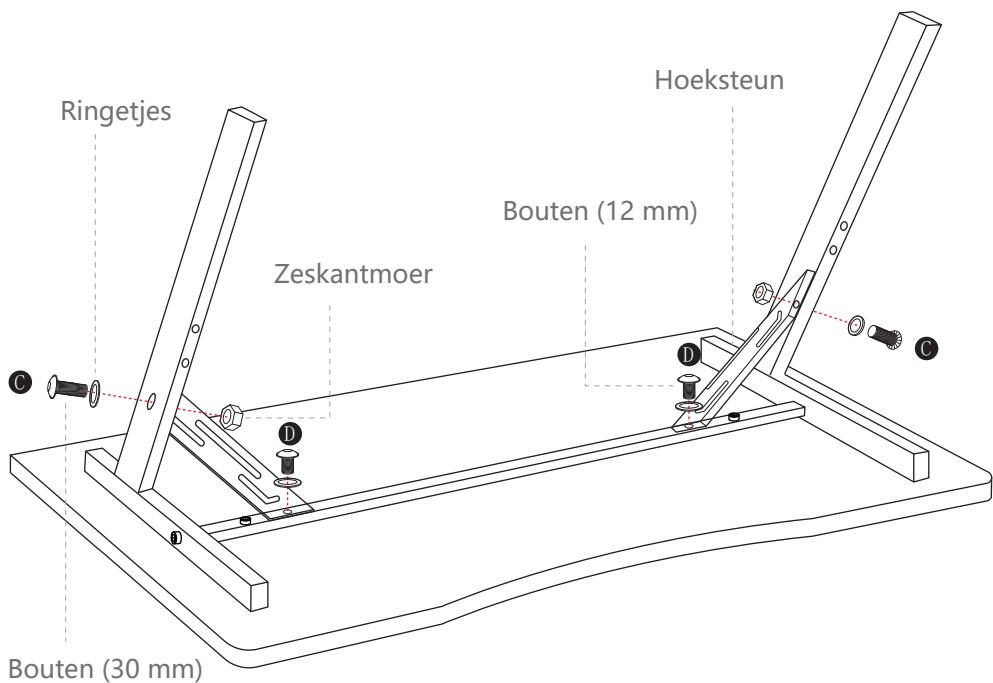

! Wees er alstublieft voorzichtig mee om de schroeven tijdens het monteren niet te strak aan te draaien. Wanneer alle schroeven op hun plaats zitten, draai ze dan allemaal tegelijk aan.

A



65mm*4



*4

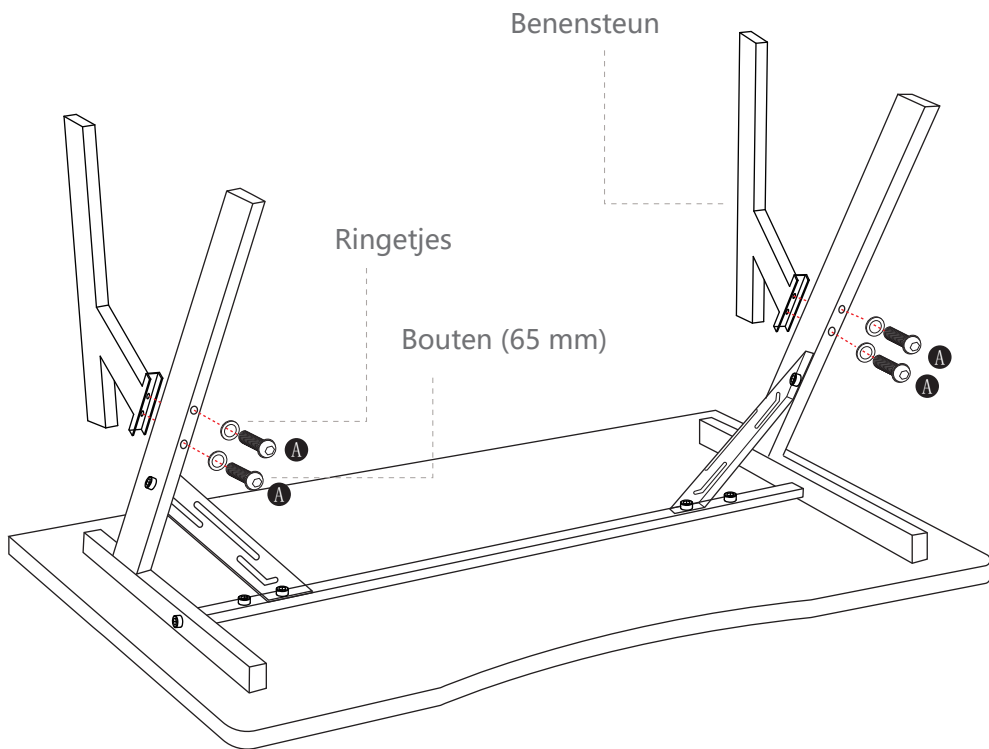

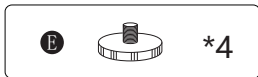

Voetjes

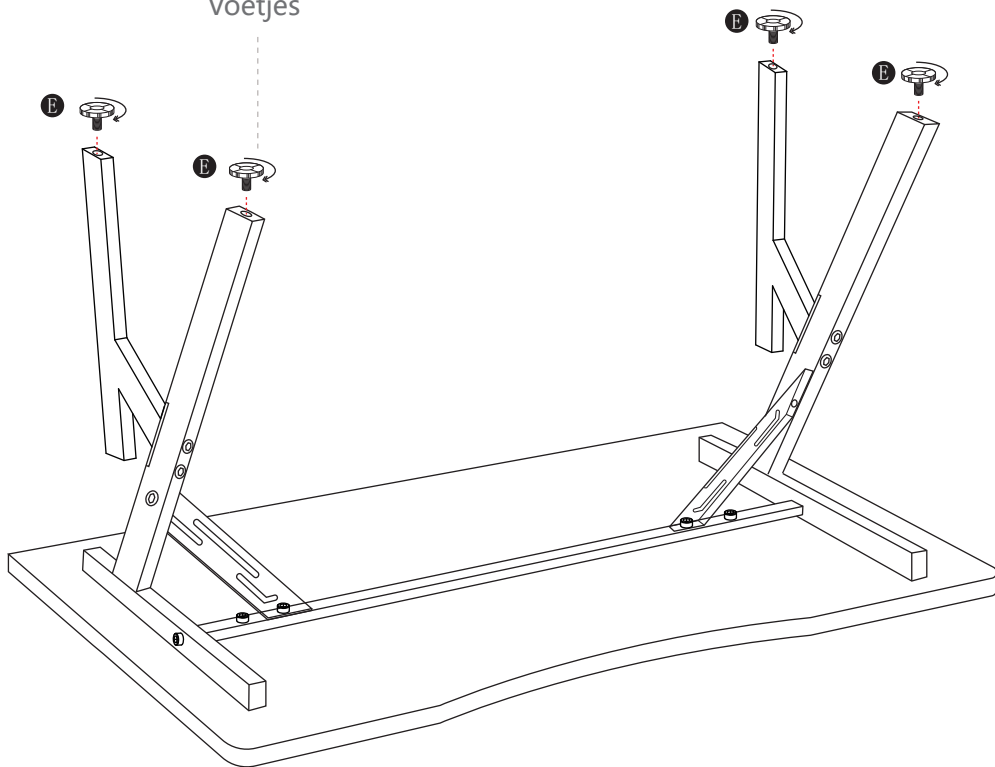

Voetjes installeren

  30mm*2

 *2

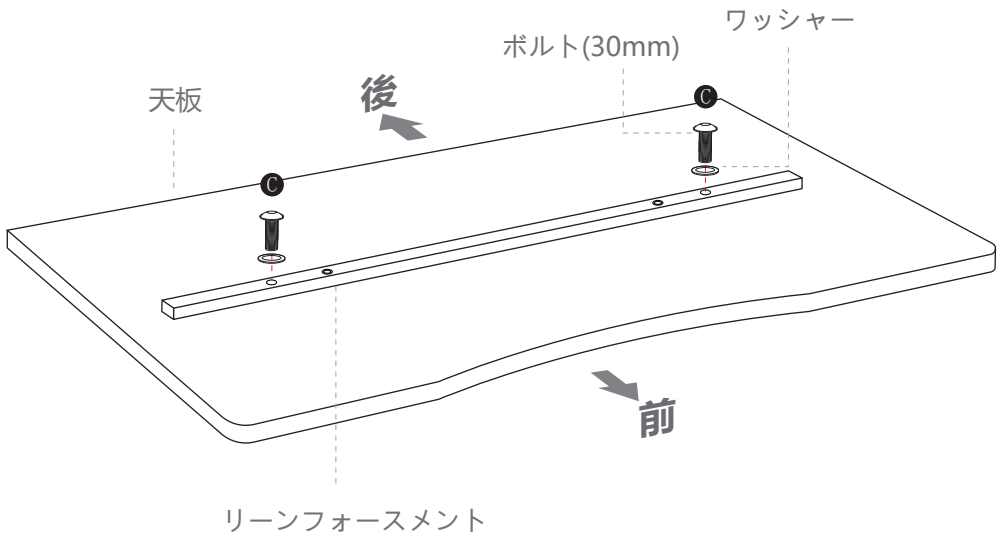

天板にリーンフォースメンを取付けます。

Ⓑ  35mm*2

 *2

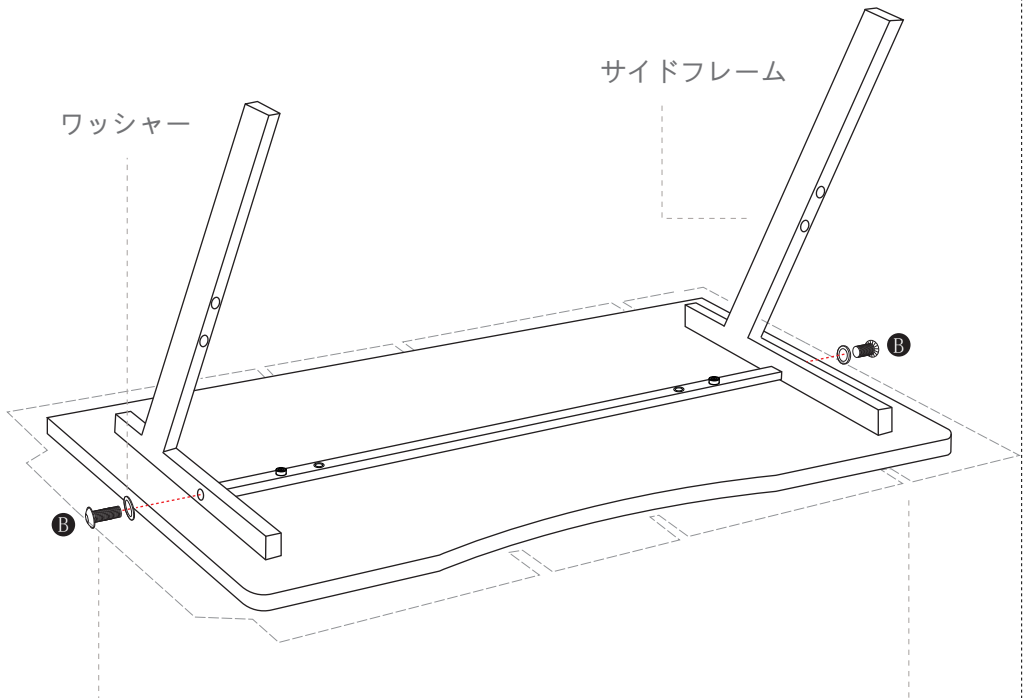

ボルト (35mm)

※ ゆるめに付けておきます

梱包用の箱を床に平らに置いてマットとして使用することで、テーブルの表面が床と直接接触して摩耗するのを防ぐことができます。

C  30mm*2

D  12mm*2

 *4

 *2

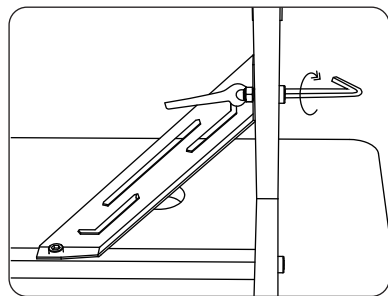
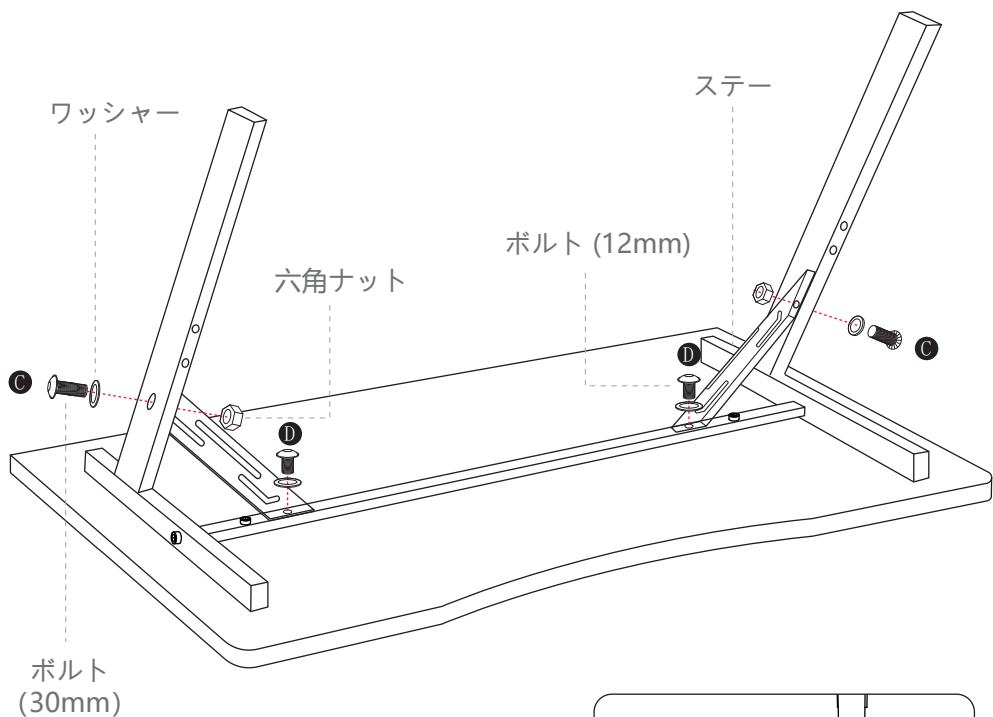

! 組立中ネジはあまりきつく締めないでください。特に注意して、全部のネジを入れるまで、しっかり締めないでください。

A



65mm*4



*4

レッグフレーム

ワッシャー

ボルト (65mm)

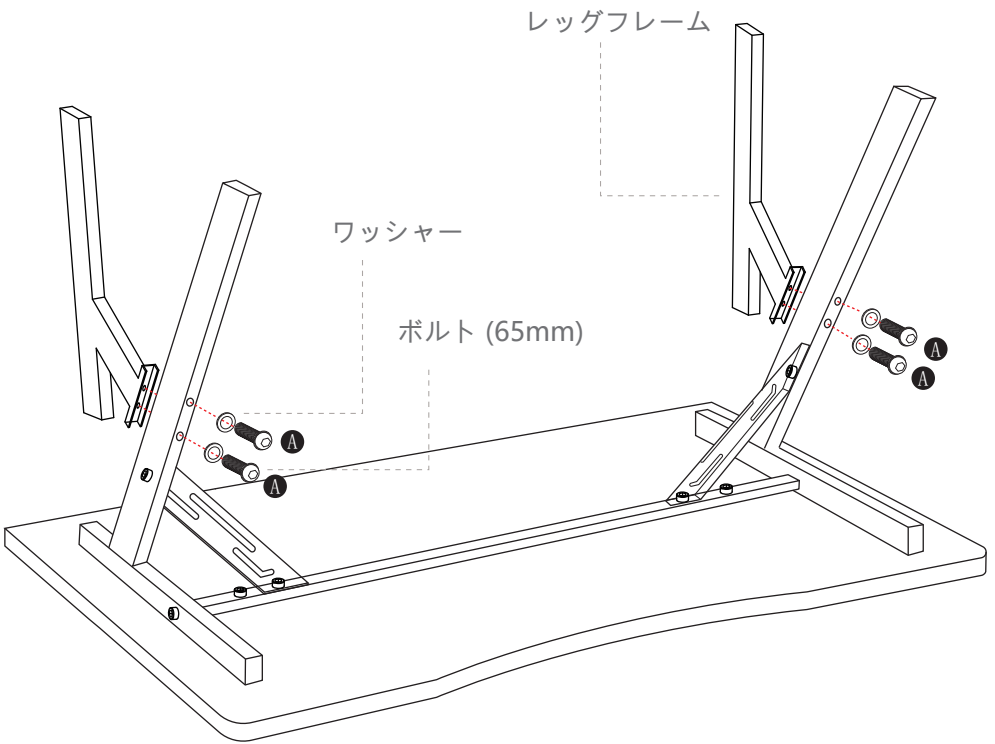

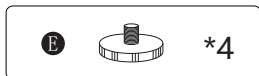

アジャスター

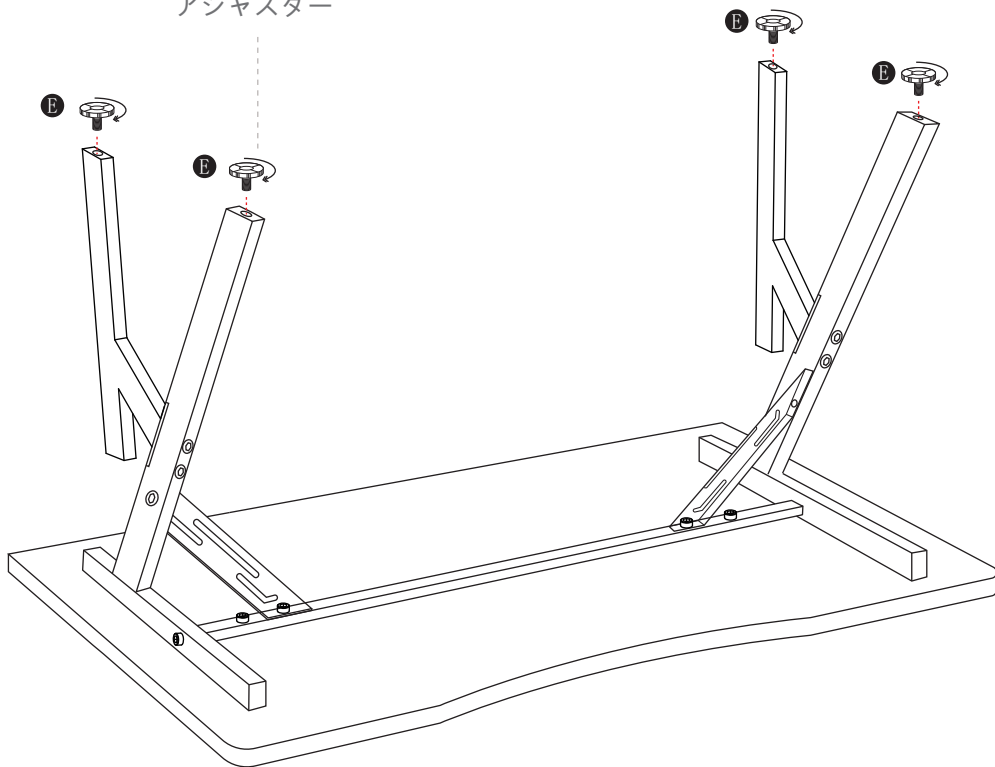

アジャスターを取付けます。