



Parker Living
A Division of Parker House

Assembly Instructions

Belmont Recliner

BEFORE ASSEMBLY

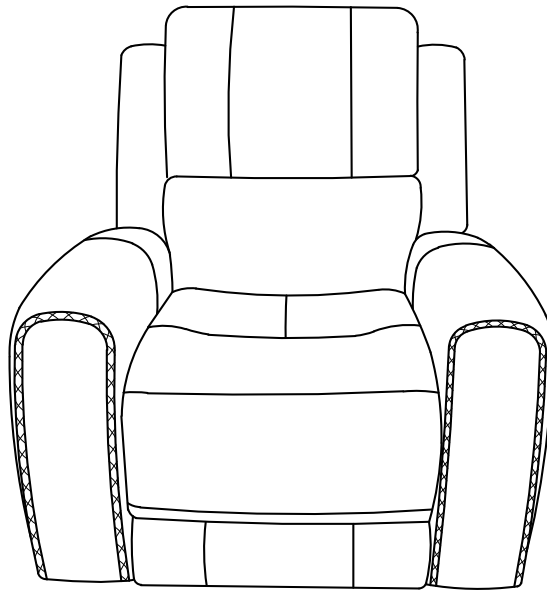

Thank you for purchasing this quality product. This product has been designed for easy assembly and constructed for durability. Please take the time to read and follow the assembly instructions carefully.

Power Zero Gravity Recliner P3



Part List

When unpacking, please be careful not to discard any parts with the packaging. Before continuing, please make sure you have the following parts:

No	Description	Sketch	Qty
A	Body		1 PC
B	Back cushion		1 PC
C	LAF Wing		1 PC
D	RAF Wing		1 PC
E	Plug Transformer		1 PC

Step 1

1. Take out the LAF wing (C) and RAF wing (D) from the bottom of the armrest.
2. Remove the transformer from the bottom of the seat.

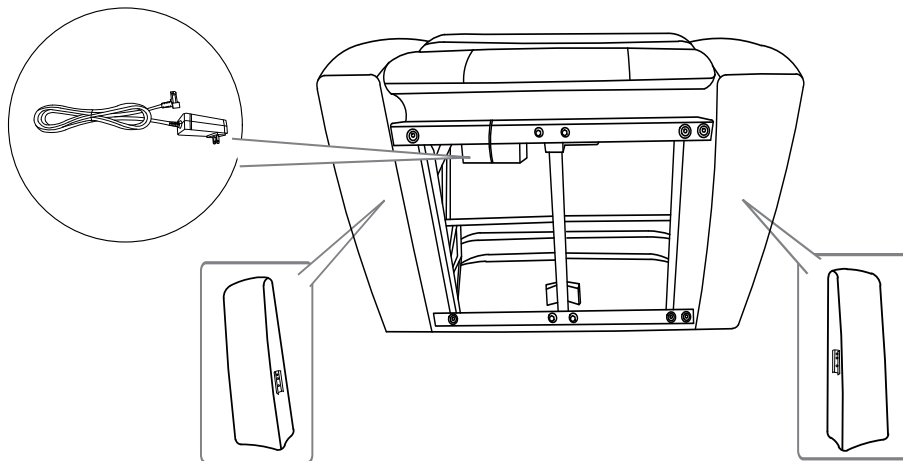

Step 2

1. Install the back cushion (B) into the body (A) by positioning the female metal receiver brackets over the male metal posts. Ensure that the female metal receiver brackets on each side line up with the seat metal posts. Push the backrest down until each side is locked into place and an audible "click" is heard;

2. The power cables on the backrest and seat are labeled (Head and Lumbar) please connect each wire correctly.

- Connect the "Head" wire to the "Head" wire.
- Connect the "Lumbar" wire to the "Lumbar" wire.

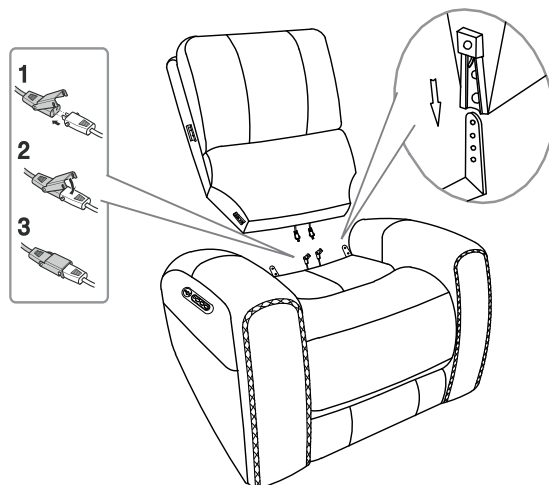

Step 3

1. Install the LAF Wing (C) and RAF Wing (D) by sliding wings in a downward motion along the side of the seat back to connect the brackets.

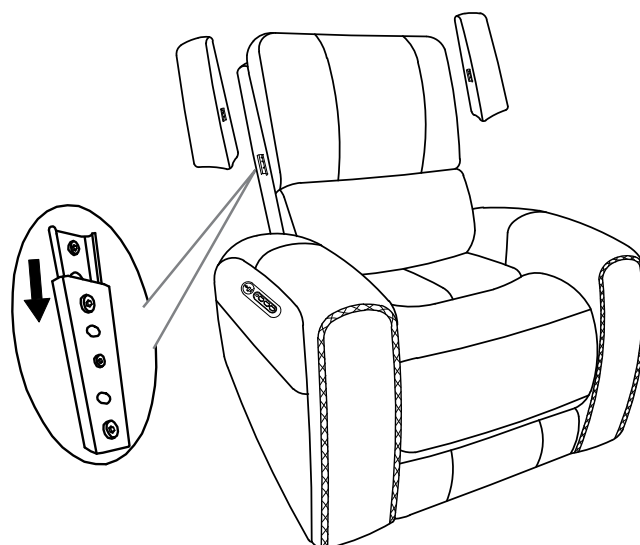

2. Attach the flap to the seat frame by pulling the flap down, and pressing the bottom under the seat base, connecting the velcro.

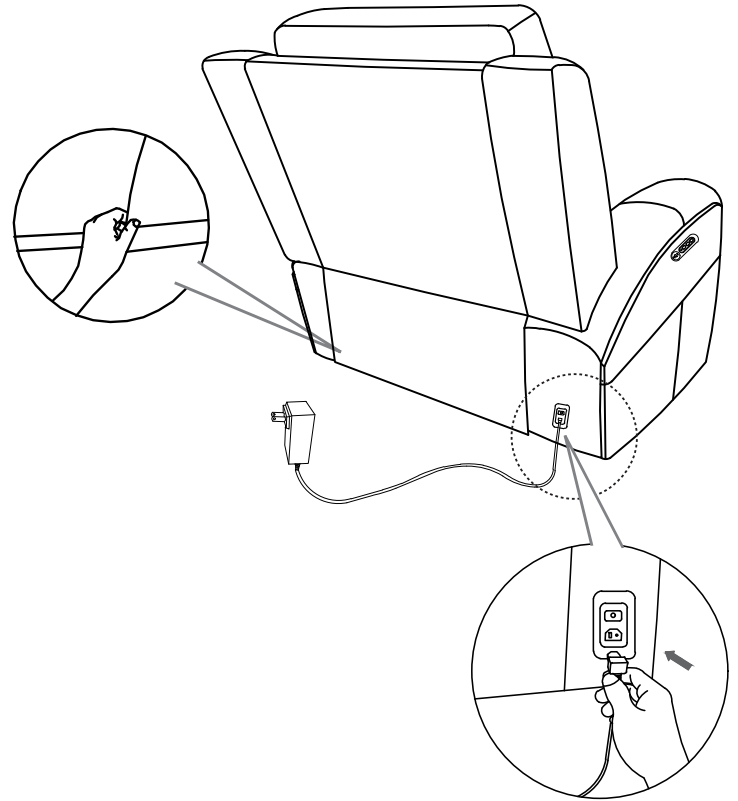

3. Connect firmly one end of the wall plug transformer cord into the DC adapter located in the lower back corner of Recliner and plug the other end into a power outlet/wall socket and enjoy.

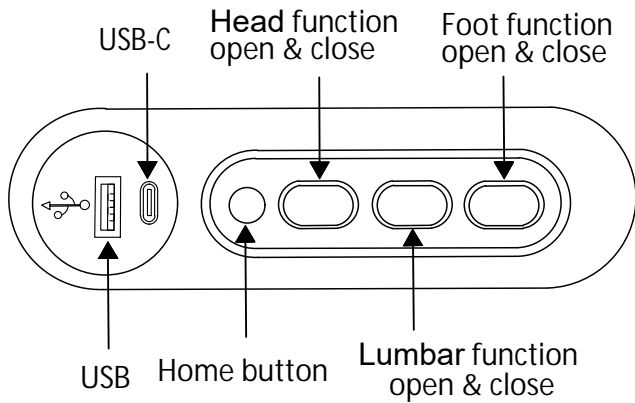

Function Display

