

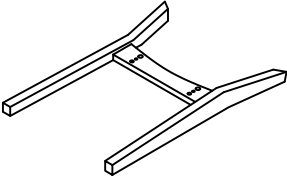

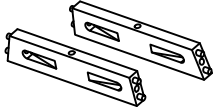

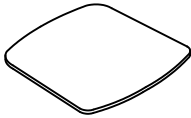

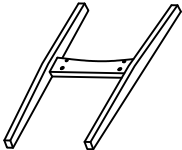
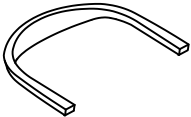

# Product Assembly Instructions

DINING □□A□

## PART LIST

 <p>A : FRONT LEG x1</p>	 <p>B : RAIL (L &amp; R) x2</p>	 <p>C : VENEER SEAT x1</p>
 <p>D : BACK LEG x1</p>	 <p>E : BACK VENEERS x1</p>	

## HARDWARE LIST

 <p>F : JCBC SCREW M6 x 50MM x4</p>	 <p>G : JCBC SCREW M6 x 60MM x2</p>	 <p>H : SPRING WASHER 1/4" x6</p>
 <p>I : WOOD DOWEL DIA 8 x 30mm x8</p>	 <p>J : CSK SOCKET SCREW M6 x 25MM x4</p>	 <p>K : METAL PLATE x4</p>
 <p>L : M4 ALLEN KEY (BALL SHAPE) LONG x1</p>	 <p>M : PAN HEAD SCREW M4 x 16MM x4</p>	

### STEP 1

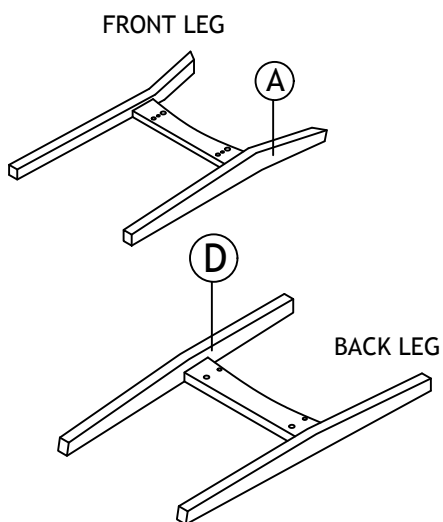

### STEP 2

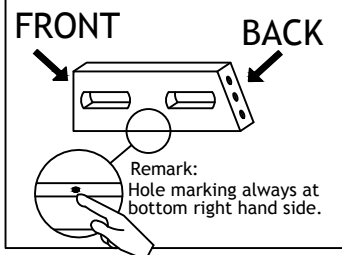
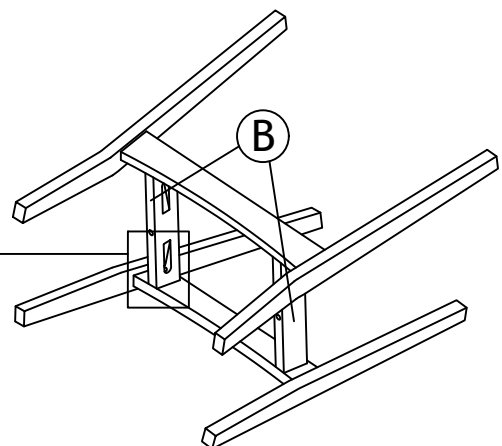
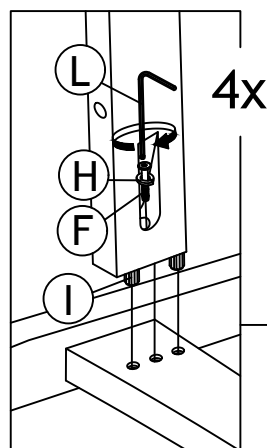

### STEP 3

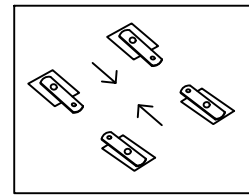
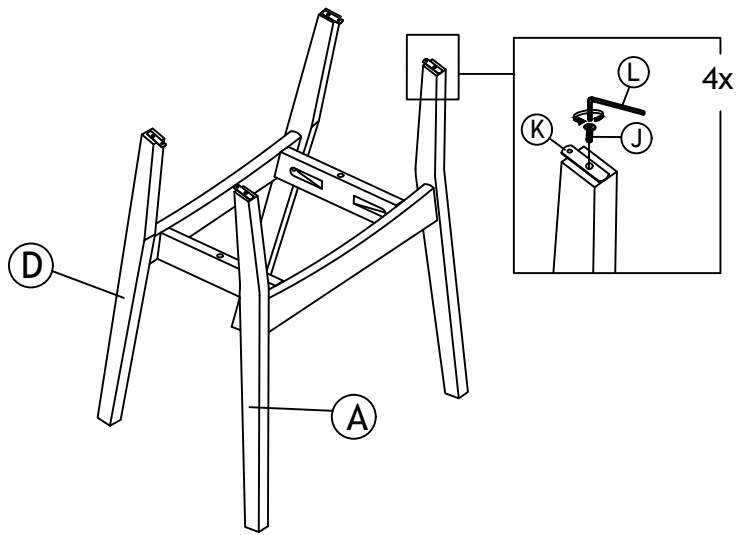

Remark:  
When assembly, make sure  
direction face to each other.

### STEP 4

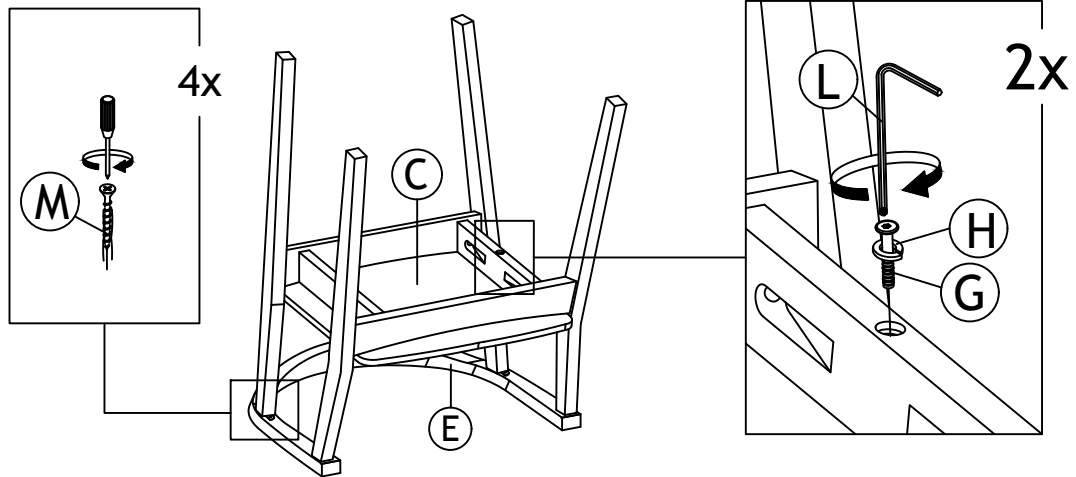

### STEP 5

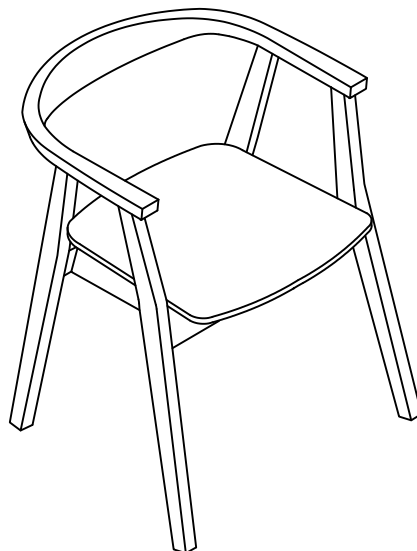



# Product Assembly Instructions

## DINING TABLE

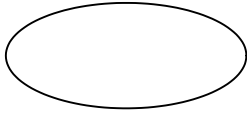
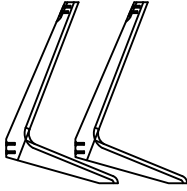
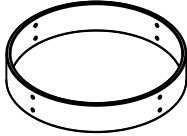
### PART LIST

 A : TABLETOP x1	 B : TABLE LEG x4	 C : METAL ROUND SUPPORT x1
--	---	---

### HARDWARE LIST

 D : JCBB SCREW M8 x 70MM x8	 E : SPRING WASHER 5/16" x8	 F : FLAT WASHER 5/16" x8
 G : JCBB SCREW M6 x 30mm (BLACK) x8	 H : ALLEN KEY M4 BALL SHAPE(LONG) x1	 I : ALLEN KEY M5 x1

### STEP 1

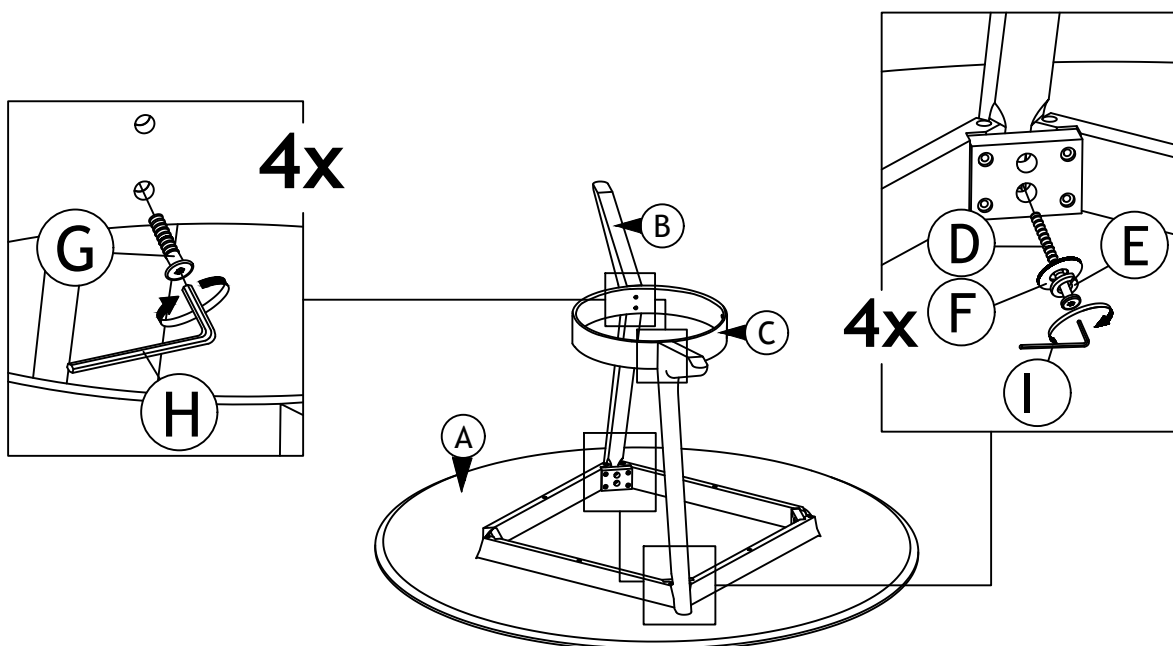

STEP 2

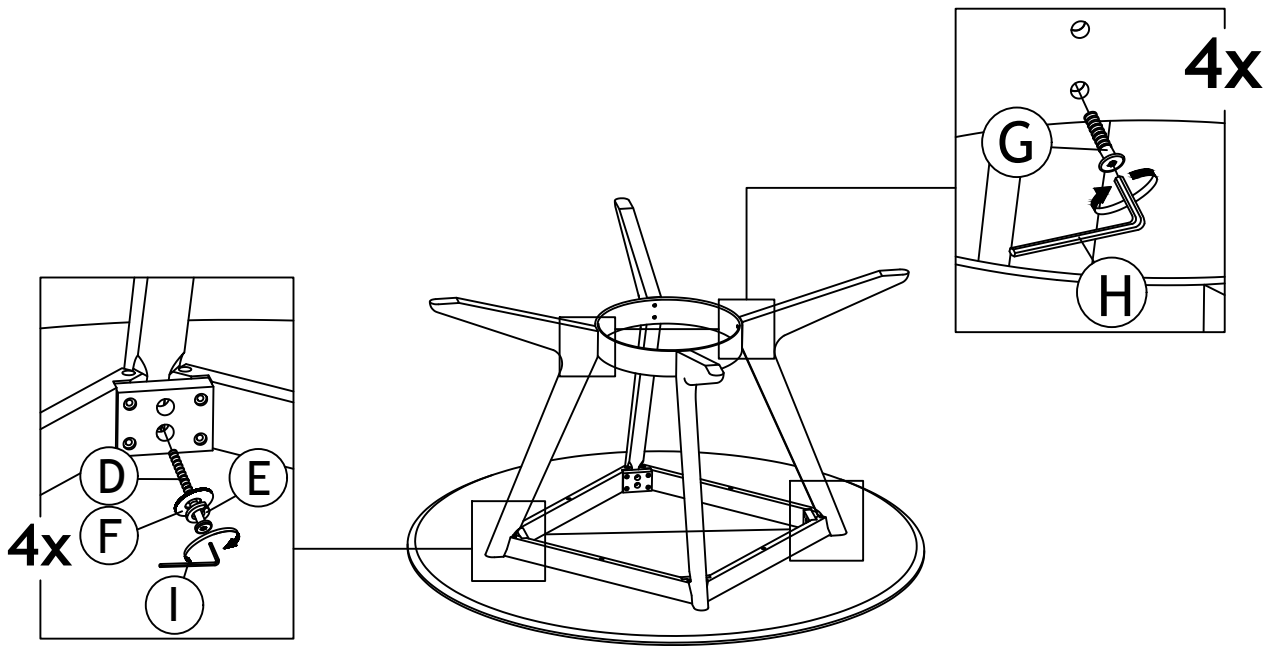

STEP 3

