

ASSEMBLY INSTRUCTION

STORAGE BENCH

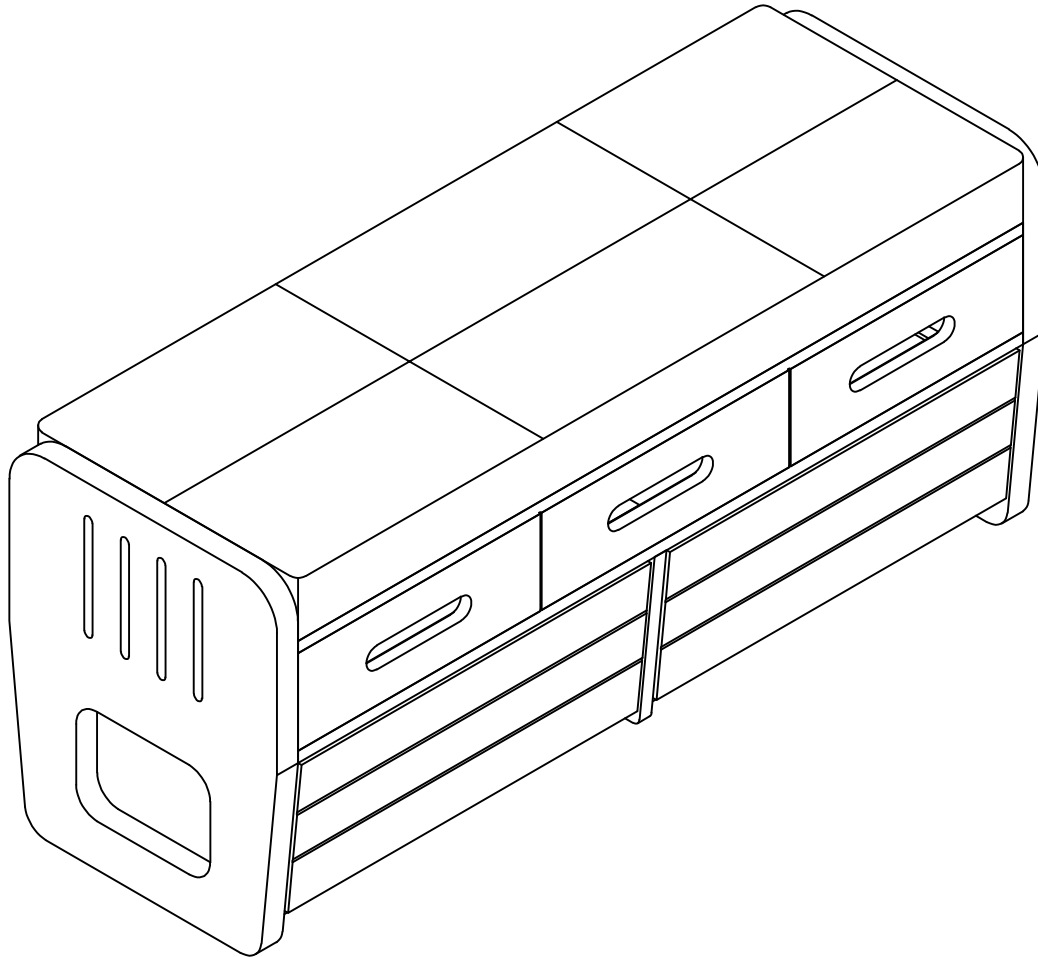

Thank you for purchasing this quality product. Be sure to check all packing material carefully for small parts which may have come loose inside the carton during shipment. Separate, identify and count all parts and hardware.

Compare with the parts list to be sure all parts are present.

"DO NOT TIGHTEN SCREWS UNTIL COMPLETELY ASSEMBLED"

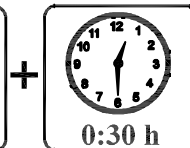
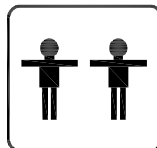
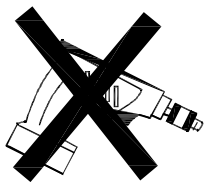

*Use of power tool to assemble this product will invalidate any claim and damage this product making unsafe !!!
*Please assemble on a clean soft surface to avoid damage.

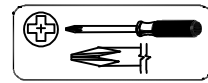

Tools Required

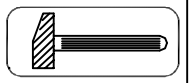

(Not included)



(Not included)

IMPORTANT:
PLEASE READ INSTRUCTION BEFORE STARTING THE ASSEMBLY

Thank you for buying our products.

Please read the installation manual carefully before installation,

we need you to follow the instructions on the accessories and hardware

step by step assembly complete, our instructions are very detailed.

Products are environmentally friendly products,

Please rest assured that you do not soak in water, do not place very heavy items,

do not malicious push and pull,

if you have any problems in the process of assembly and use, please contact us.

Thank you again for your purchase of our products,

I wish you a happy life.

Detail View - BENCH

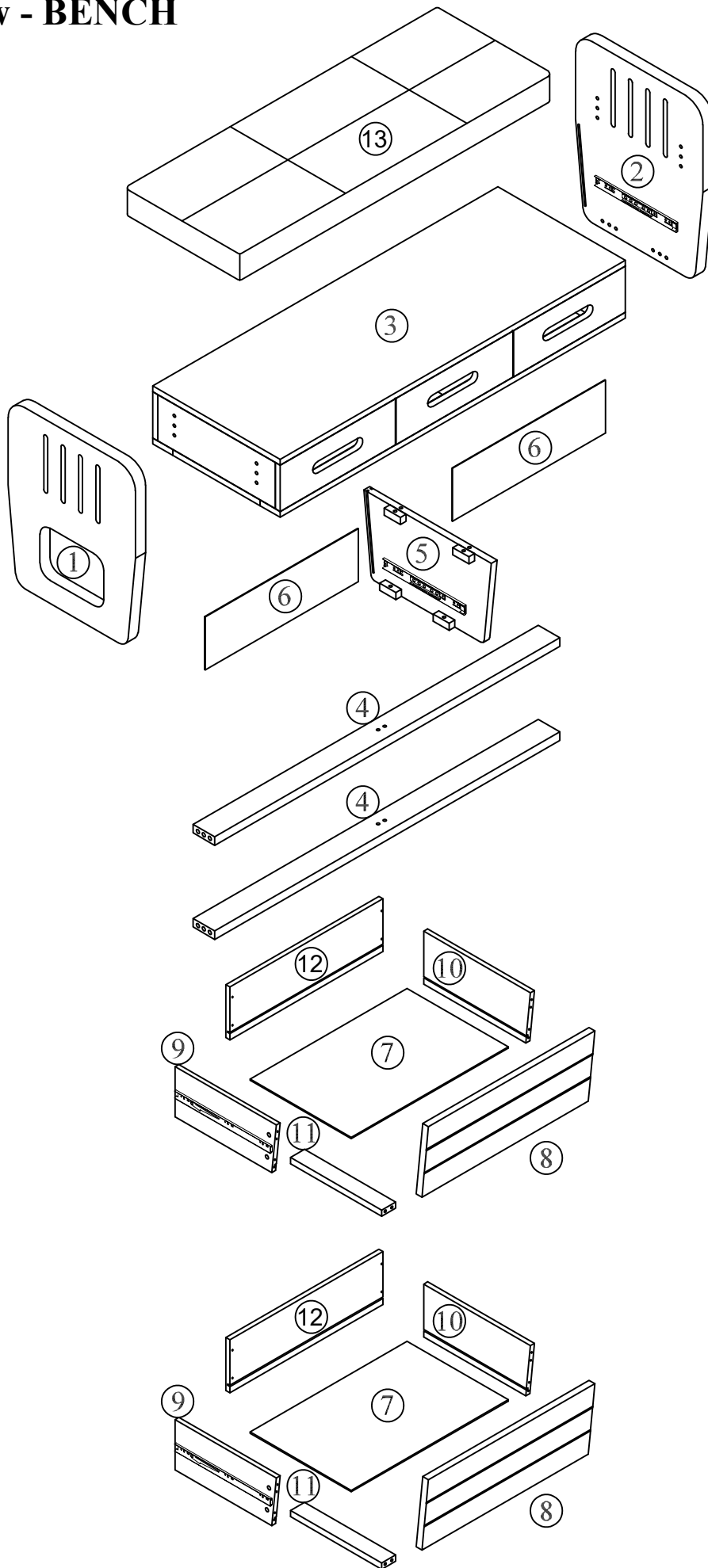

ntifying the Hardware-Identify the hardware using the illustrations below.

Part List - BENCH

1



Left side - 1pc

2



Right side - 1pc

3

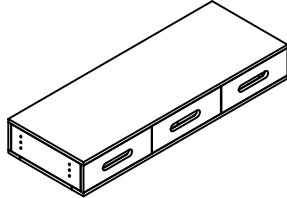

Top frames - 1pc

4

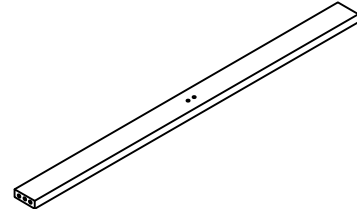

Bottom horizontal rail - 2pcs

5

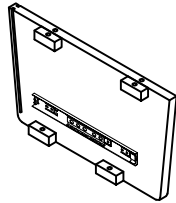

Middle vertical panel - 1pc

6

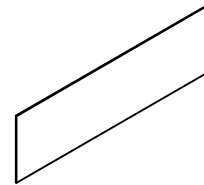

Back panel - 2pcs

7

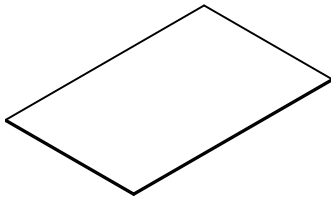

Drawer bottom - 2pcs

8

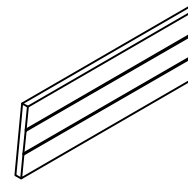

Drawer front - 2pcs

9

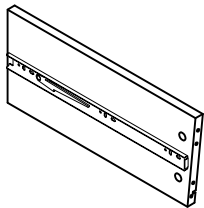

Drawer left - 2pcs

10

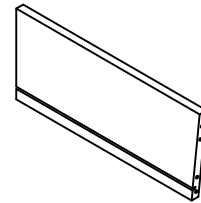

Drawer right - 2pcs

11

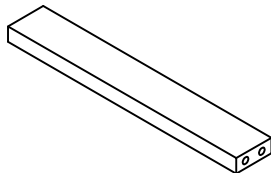

Drawer bottom support - 2pcs

12

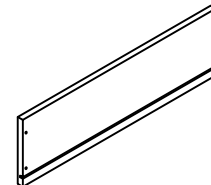



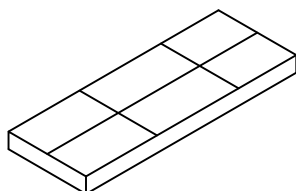

Drawer back - 2pcs

13



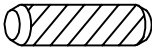
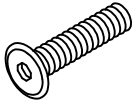
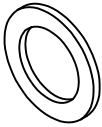

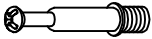
Cushions - 1pc

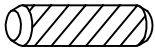
Hardware List

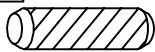
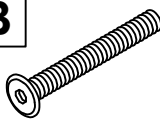
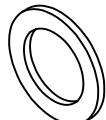

<p>A</p>  <p>Ø8*30mm</p>	<p>B</p>  <p>1/4"*40mm</p>	<p>C</p>  <p>Ø1/4"*16mm</p>
<p>Wood dowel (16pcs)</p>	<p>Bolt (16pcs)</p>	<p>Flat washer (16pcs)</p>
<p>D</p>  <p>Ø1/4"</p>	<p>E</p>  <p>#4*25mm</p>	<p>F</p>  <p>Ø7.5*36mm</p>
<p>Lock washer (16pcs)</p>	<p>Round head screw (12pcs)</p>	<p>Cam bolt (10pcs)</p>
<p>G</p>  <p>Ø15*9mm</p>	<p>H</p>  <p>4mm</p>	<p>K</p>  <p>Ø6*30mm</p>
<p>Cam lock (10pcs)</p>	<p>Allen key(1pc)</p>	<p>Wood dowel (10pcs)</p>

STEP:1

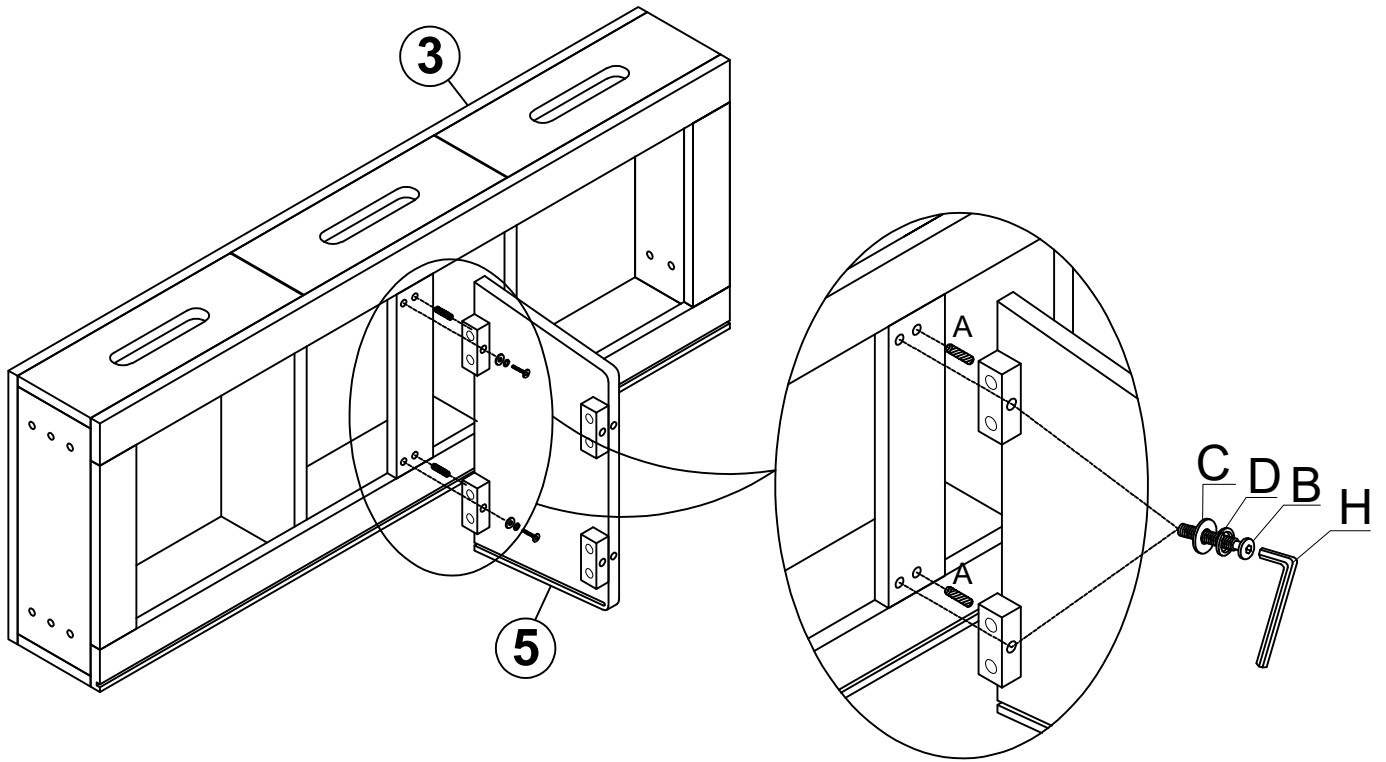
A 	B 	C 	D 
2PCS	2PCS	2PCS	2PCS

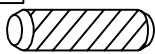
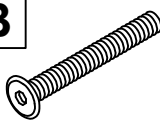
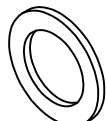

STEP:2

A 	B 	C 	D 
2PCS	2PCS	2PCS	2PCS

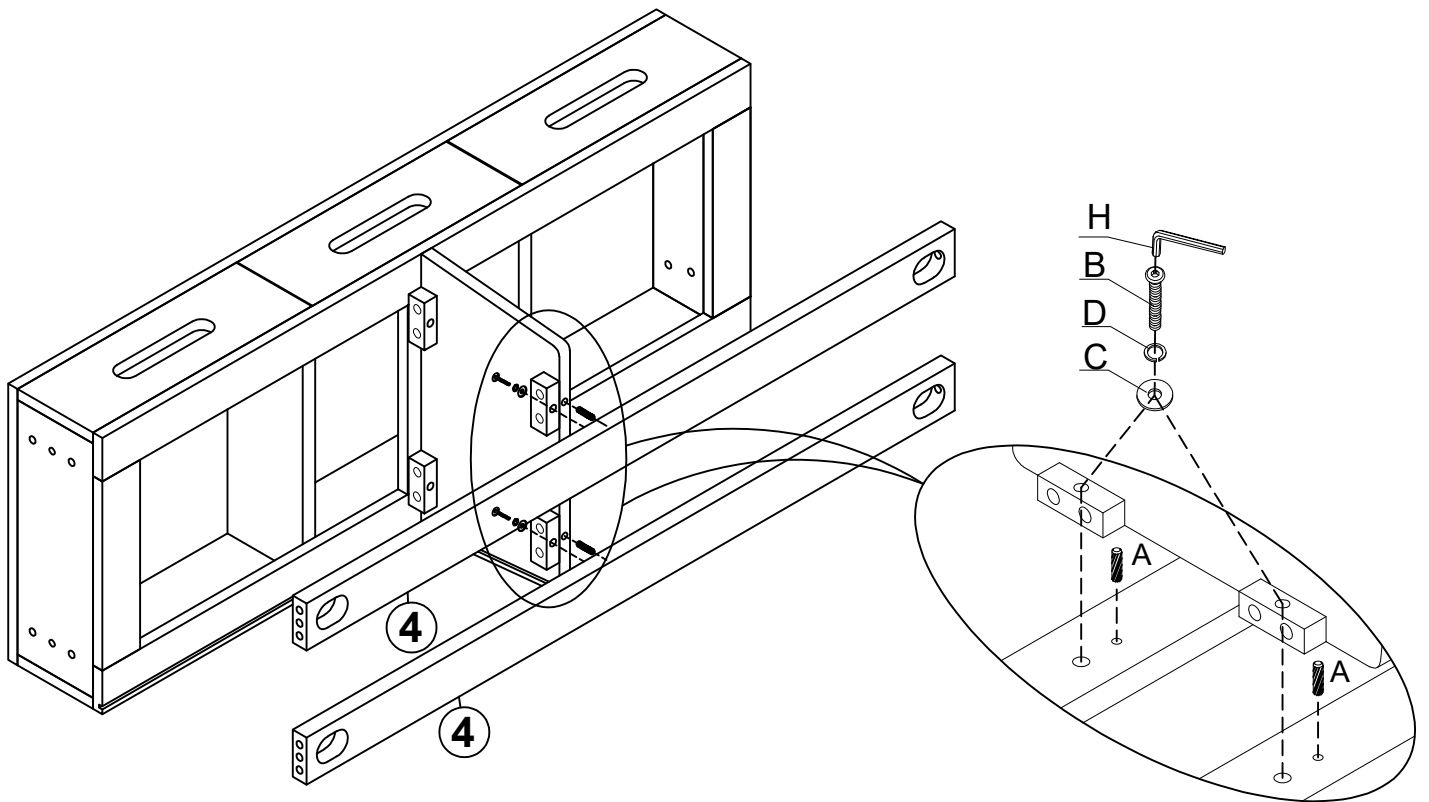

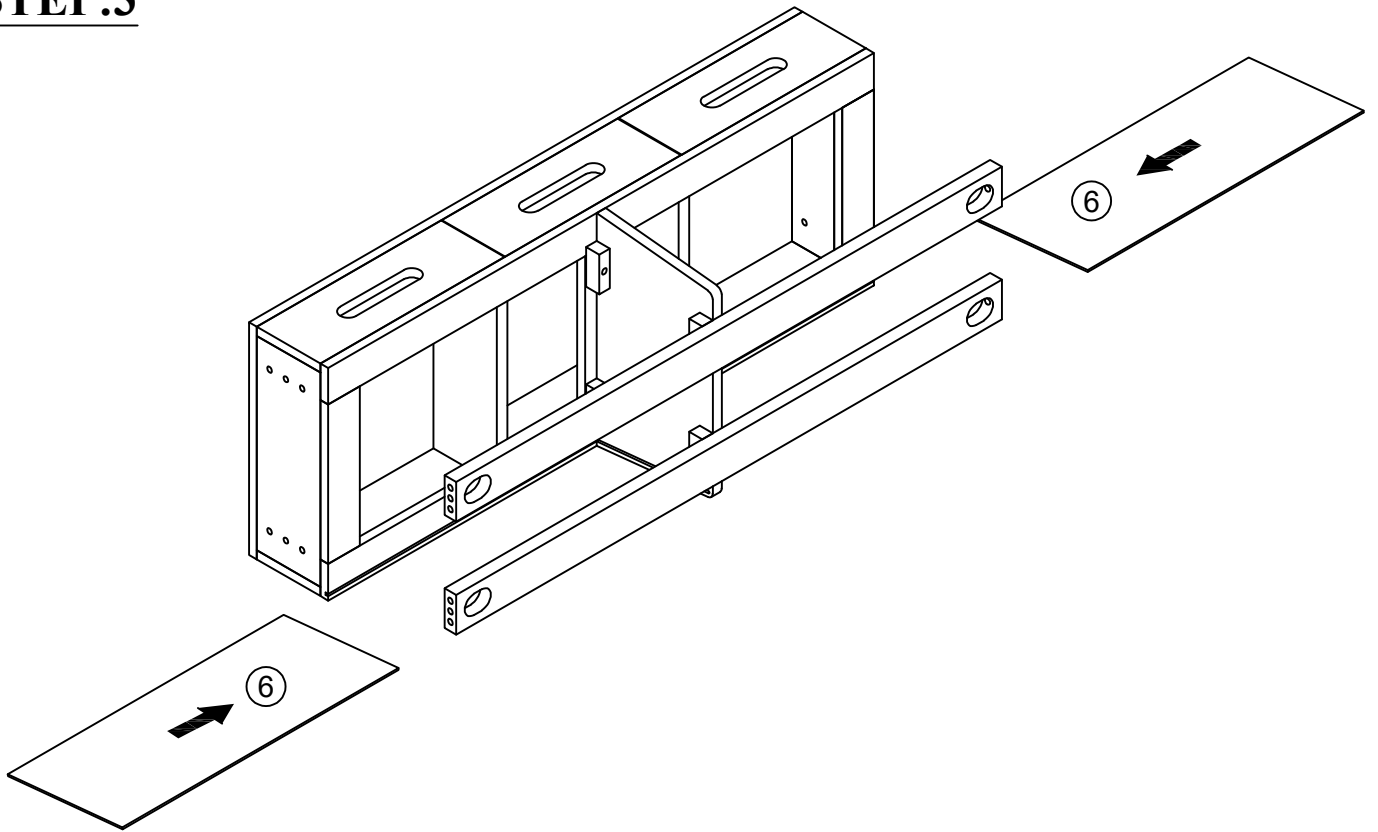

STEP:3

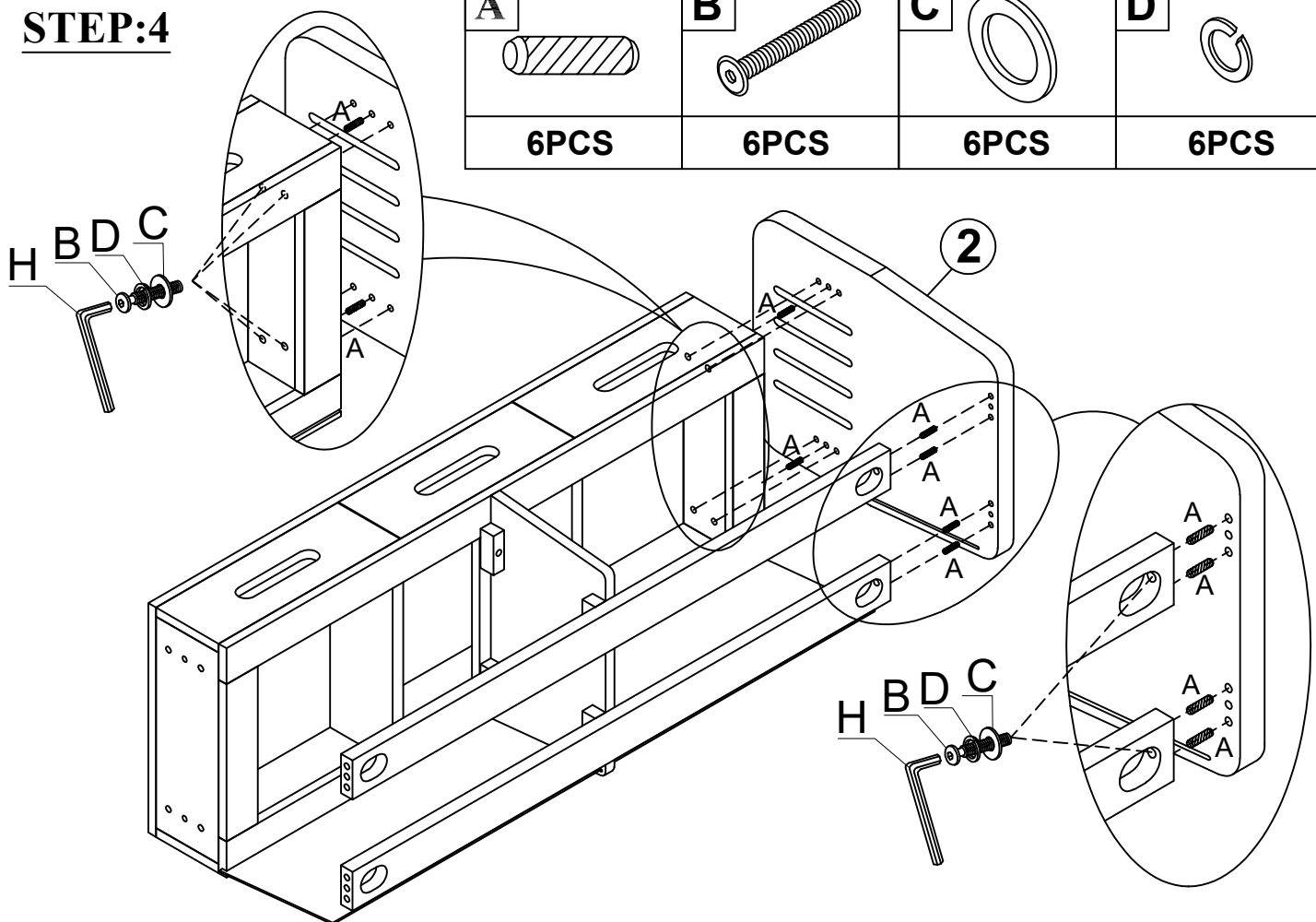

STEP:4

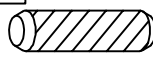
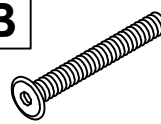

STEP:5

A 	B 	C 	D 
6PCS	6PCS	6PCS	6PCS

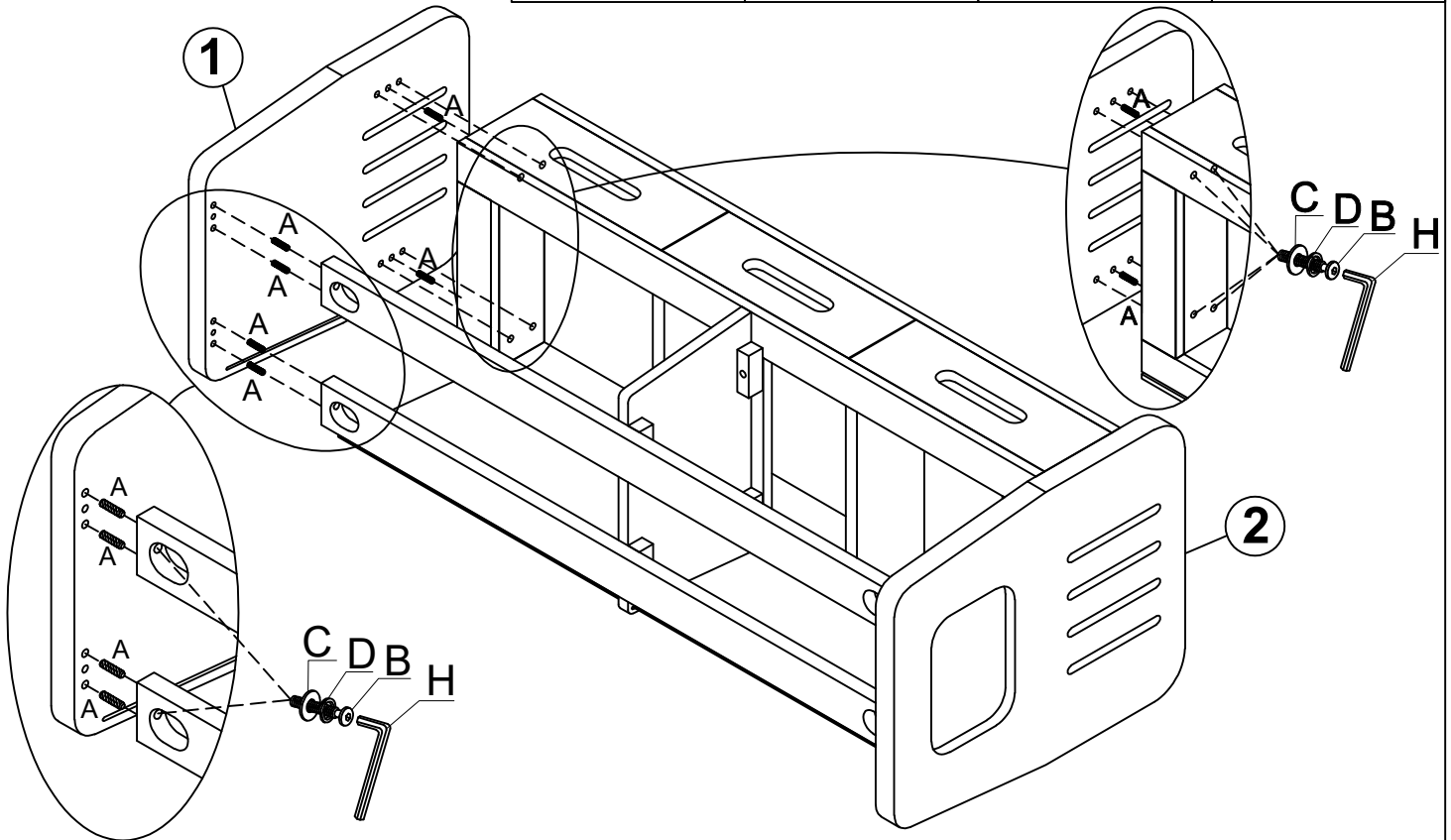

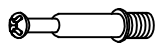

STEP:6

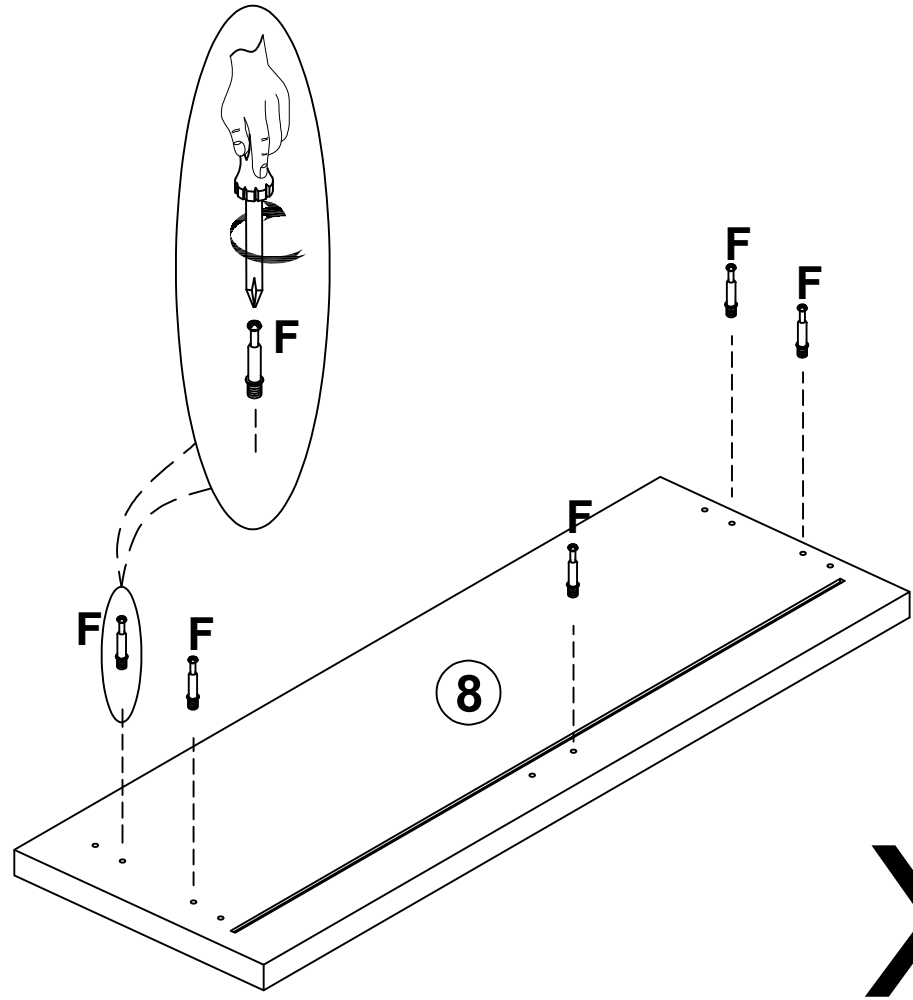
F 
10PCS

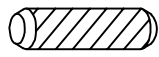

X2

STEP:7

G		K		E	
10PCS		10PCS		12PCS	

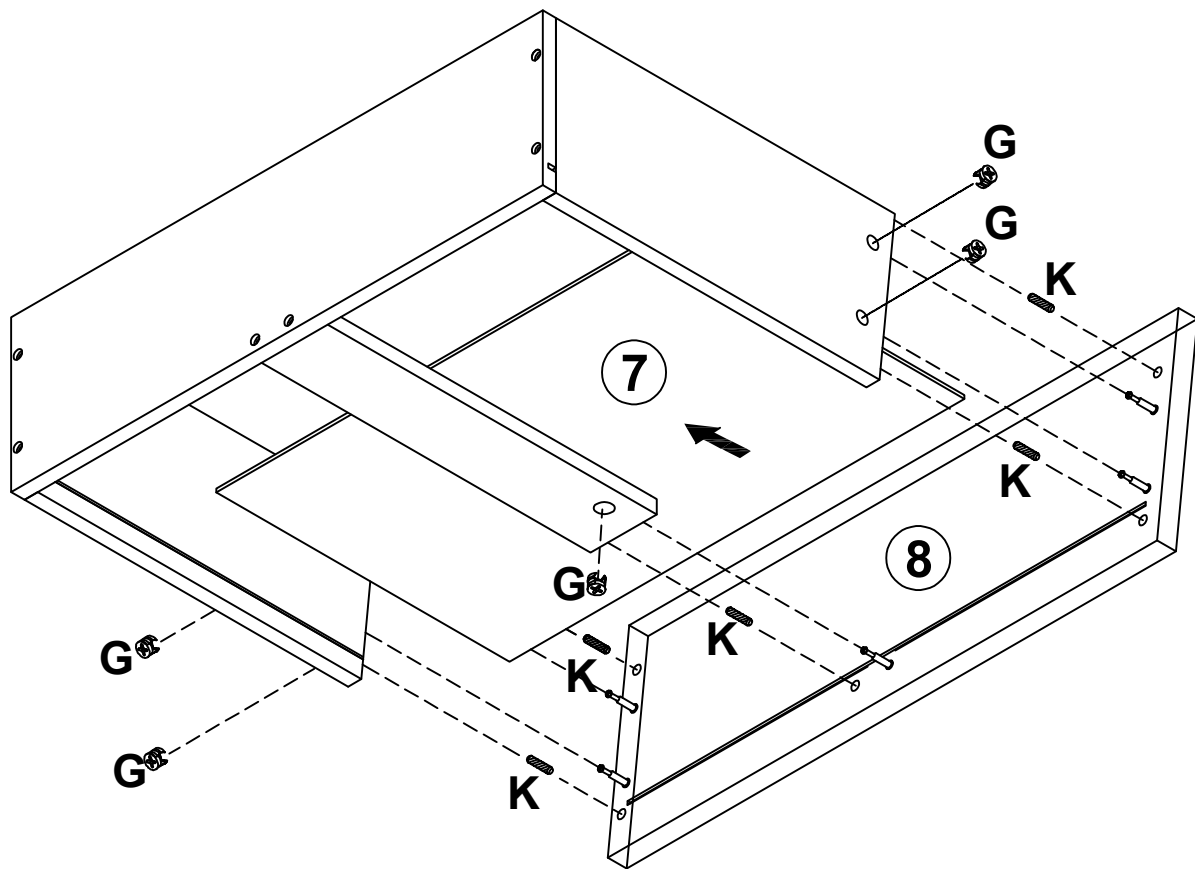
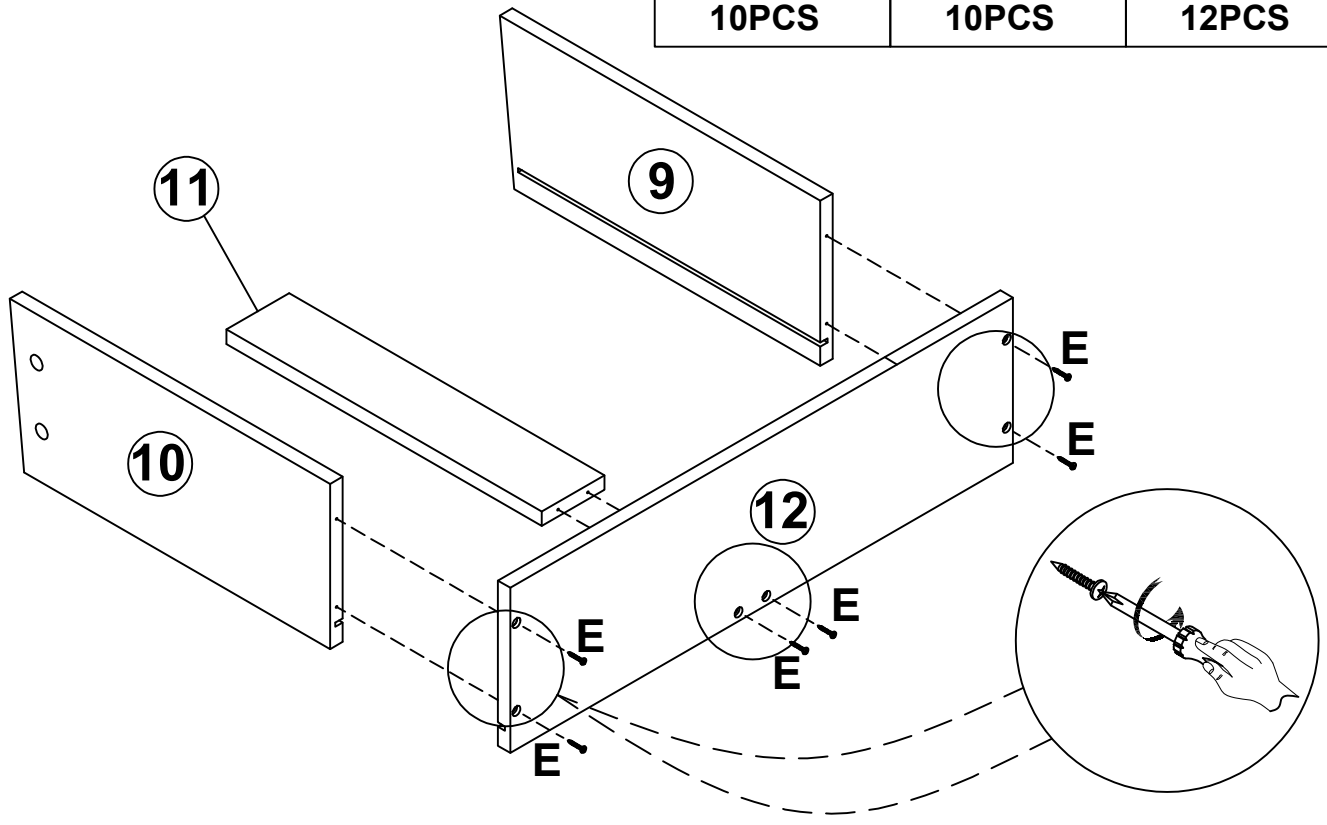

X2

STEP:8

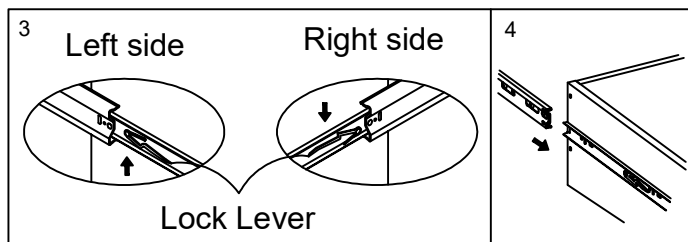
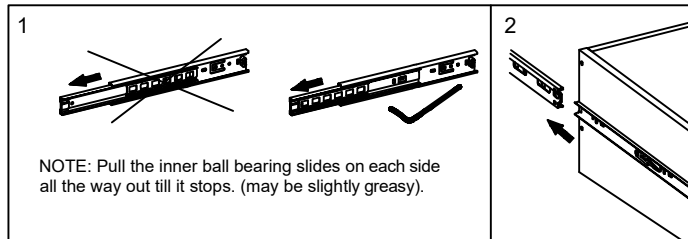
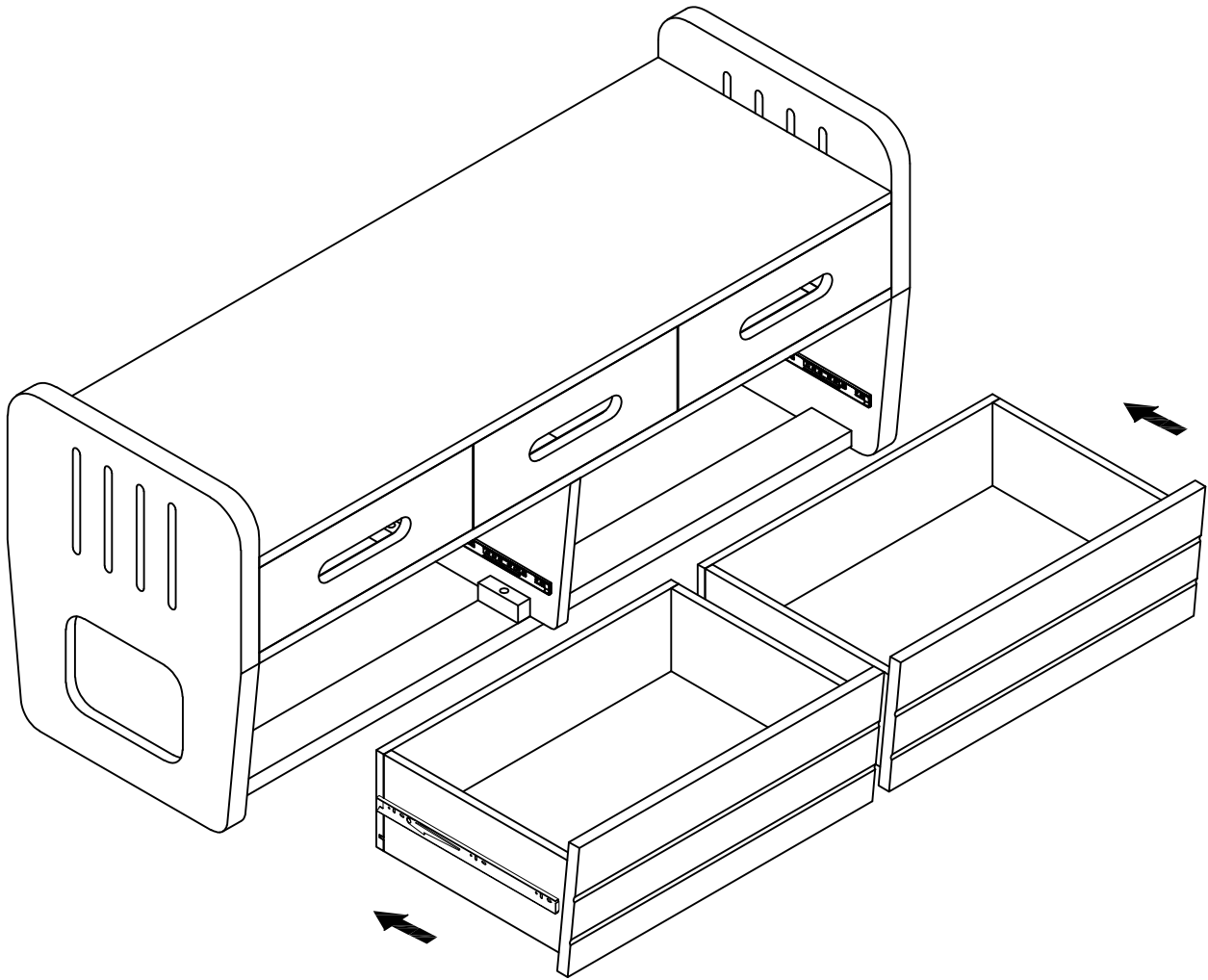

STEP:9

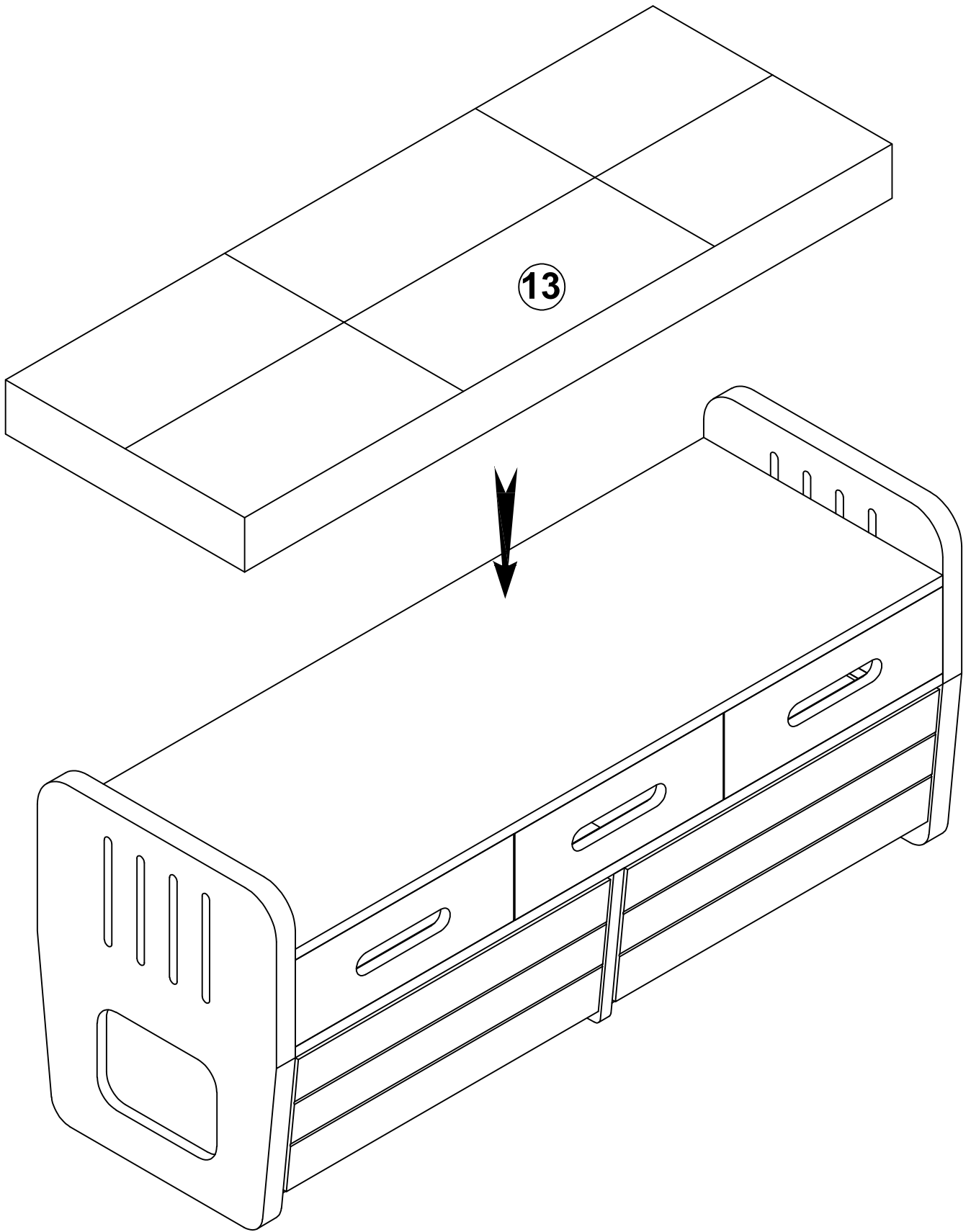

FINISH

