

ASSEMBLY INSTRUCTIONS

30INCH BATHROOM VANITY (COMBO)

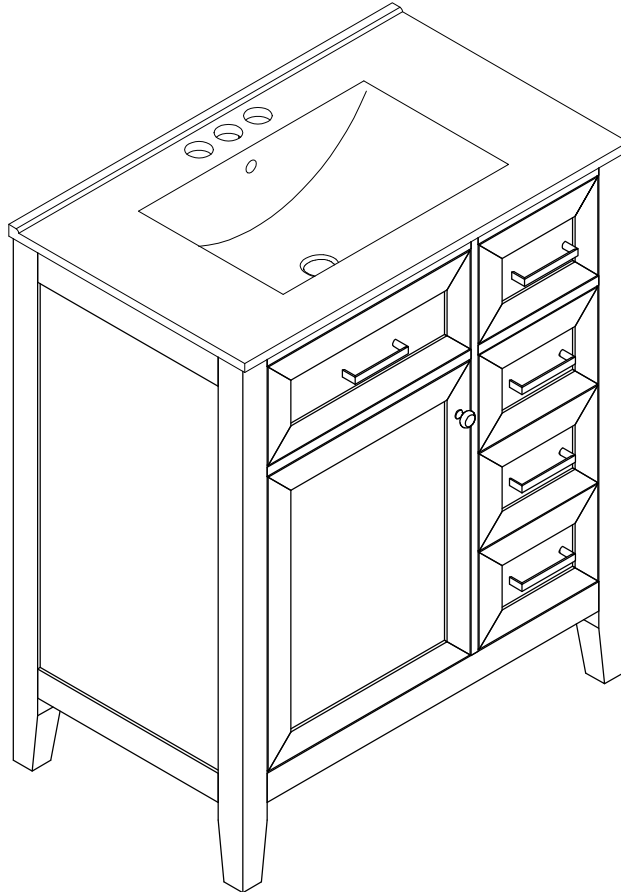

Thank you for purchasing this quality product. Be sure to check all packing material carefully for small parts which may have come loose inside the carton during shipment. Separate, identify and count all parts and hardware. Compare with the parts list to be sure all parts are present.
"DO NOT TIGHTEN SCREWS UNTIL COMPLETELY ASSEMBLED"

*** Use of power tool to assemble this product will invalidate any claim and damage this product making unsafe !!!**
*** Please assemble on a clean soft surface to avoid damage.**

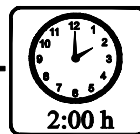

Tools Required



(Not included)



(Not included)

IMPORTANT:

PLEASE READ INSTRUCTION BEFORE STARTING THE ASSEMBLY

Thank you for buying our products.

Please read the installation manual carefully before installation,

we need you to follow the instructions on the accessories and hardware

step by step assembly complete, our instructions are very detailed.

Products are environmentally friendly products,

Please rest assured that you do not soak in water, do not place very heavy items,

do not malicious push and pull,

if you have any problems in the process of assembly and use, please contact us.

Thank you again for your purchase of our products,





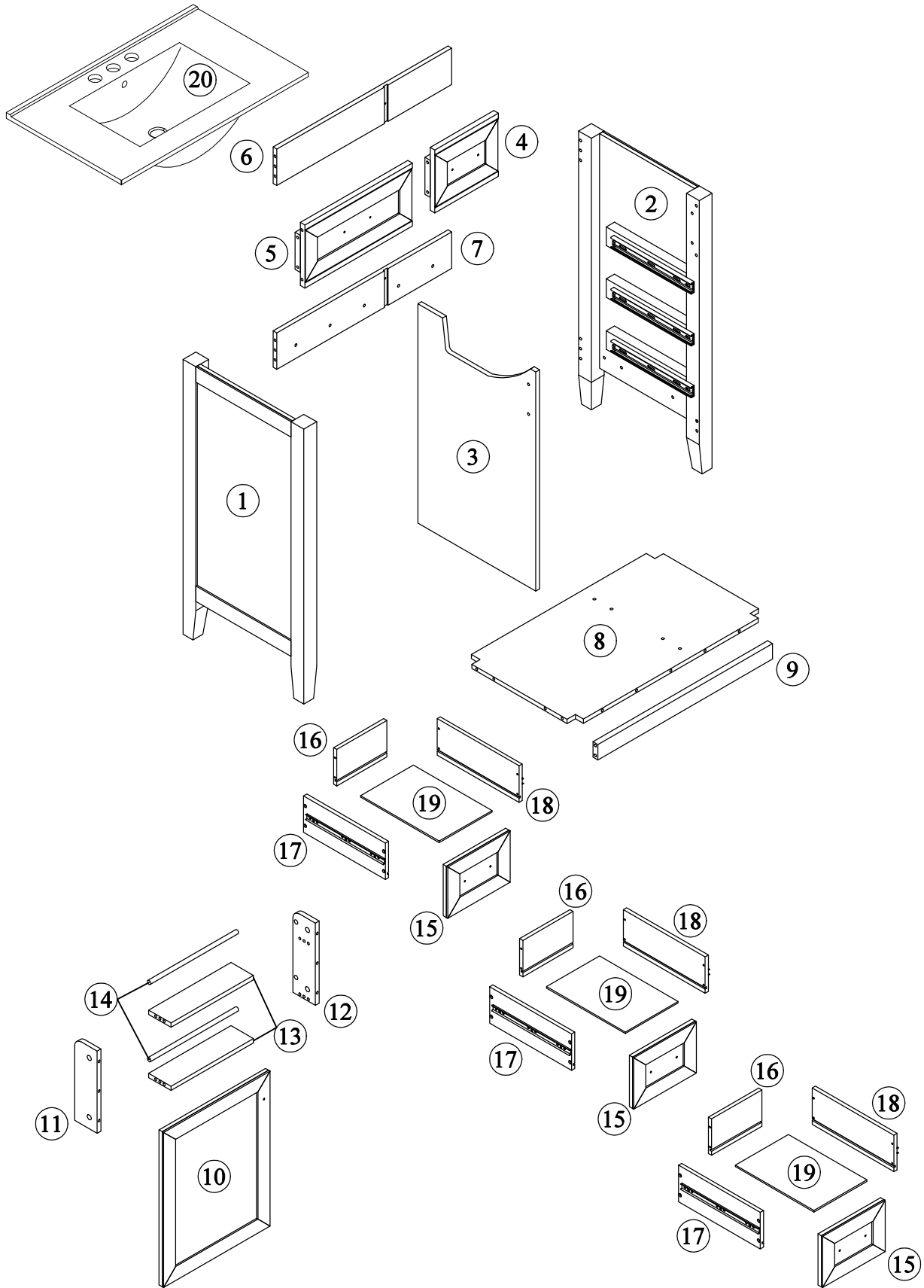

I wish you a happy life.

Detail View - CABINET

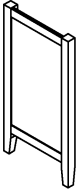
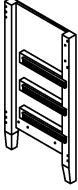

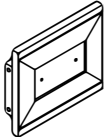
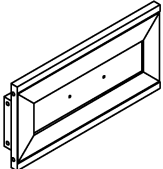
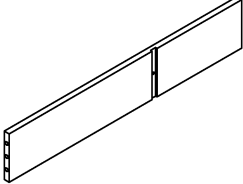
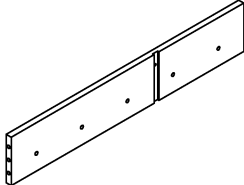
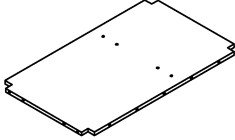
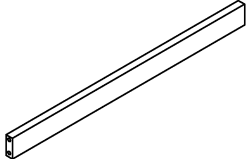
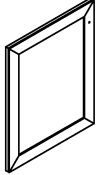
Identifying the Hardware-Identify the hardware using the illustrations below.

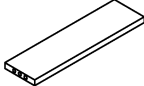





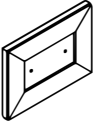
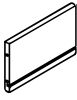
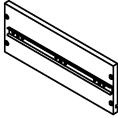
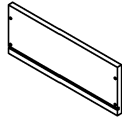
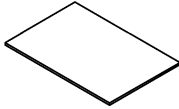
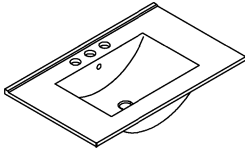



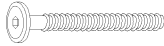

Part List

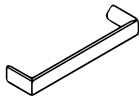
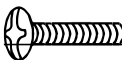
<p>1</p>  <p>Side Panel (L) - 1pc</p>	<p>2</p>  <p>Side Panel (R) - 1pc</p>
<p>3</p>  <p>Mid Panel - 1pc</p>	<p>4</p>  <p>Drawer Fake (R) - 1pc</p>
<p>5</p>  <p>Drawer Fake (L) - 1pc</p>	<p>6</p>  <p>Top Panel Rear - 1pc</p>
<p>7</p>  <p>Bottom Panel Rear - 1pc</p>	<p>8</p>  <p>Bottom Panel - 1pc</p>
<p>9</p>  <p>Bottom Crossbar Front - 1pc</p>	<p>10</p>  <p>Cabinet Door - 1pc</p>
<p>11</p>  <p>Door Side Panel (L) - 1pc</p>	<p>12</p>  <p>Door Side Panel (R) - 1pc</p>
<p>13</p>  <p>Door Mid Panel - 2pcs</p>	<p>14</p>  <p>Round Bar - 2pcs</p>

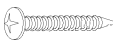
Part List

<p>15</p>  <p>Drawer Face - 3pcs</p>	<p>16</p>  <p>Drawer Back Panel - 3pcs</p>
<p>17</p>  <p>Drawer Side Panel (L) - 3pcs</p>	<p>18</p>  <p>Drawer Side Panel (R) - 3pcs</p>
<p>19</p>  <p>Bottom Drawer Panel - 3pcs</p>	<p>20</p>  <p>Sink - 1pc</p>

Hardware List

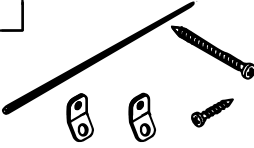
<p>A</p>  <p>ø13x1/4"x28mm</p>	<p>B</p>  <p>ø13x1/4"x50mm</p>	<p>C</p>  <p>ø1/4"x16x1mm</p>
<p>Hex-Head bolts(4pcs) Hex-Head bolts(2pcs) Washer(6pcs)</p>		
<p>D</p>  <p>ø6x35mm</p>	<p>E</p>  <p>ø14.5x12mm</p>	<p>F</p> 
<p>Three in one bolts(34pcs) Three in one lock(34pcs) Handle (1pc)</p>		
<p>G</p> 	<p>H</p>  <p>ø5/32"x20mm</p>	<p>I</p>  <p>ø5/32"x15mm</p>
<p>Handle (5pcs) Handle screw (1pc) Handle screw (4pcs)</p>		
<p>J</p>  <p>ø5/32"x25mm</p>	<p>K</p>  <p>ø8xø4x25mm</p>	<p>L</p>  <p>ø8xø4x32mm</p>
<p>Handle screw (6pcs) Round head screw(2pcs) Round head screw(24pcs)</p>		
<p>M</p> 	<p>N</p>  <p>ø7xø3.5x15mm</p>	<p>O</p>  <p>ø8x30mm</p>
<p>Damping hinge (2pcs) Flat head screw(12pcs) Wood dowel(30pcs)</p>		
<p>P</p>  <p>4mm</p>	<p>Q</p> 	
<p>Allen key(1pc) Anti fall hardware(1set)</p>		

STEP: 1

D

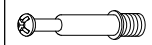

22PCS

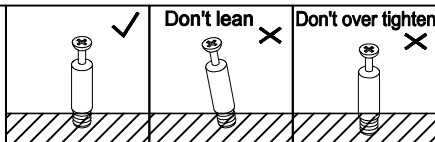
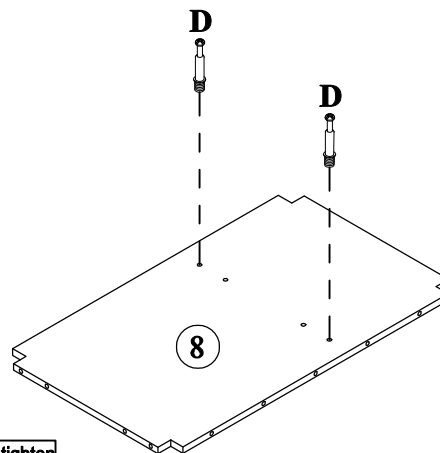
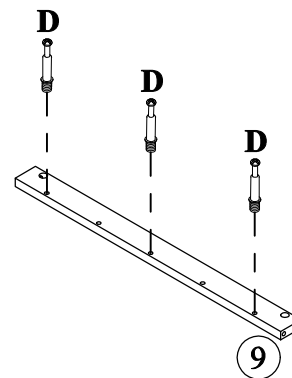
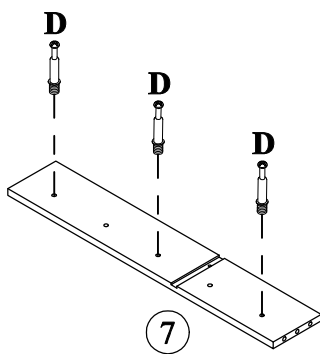
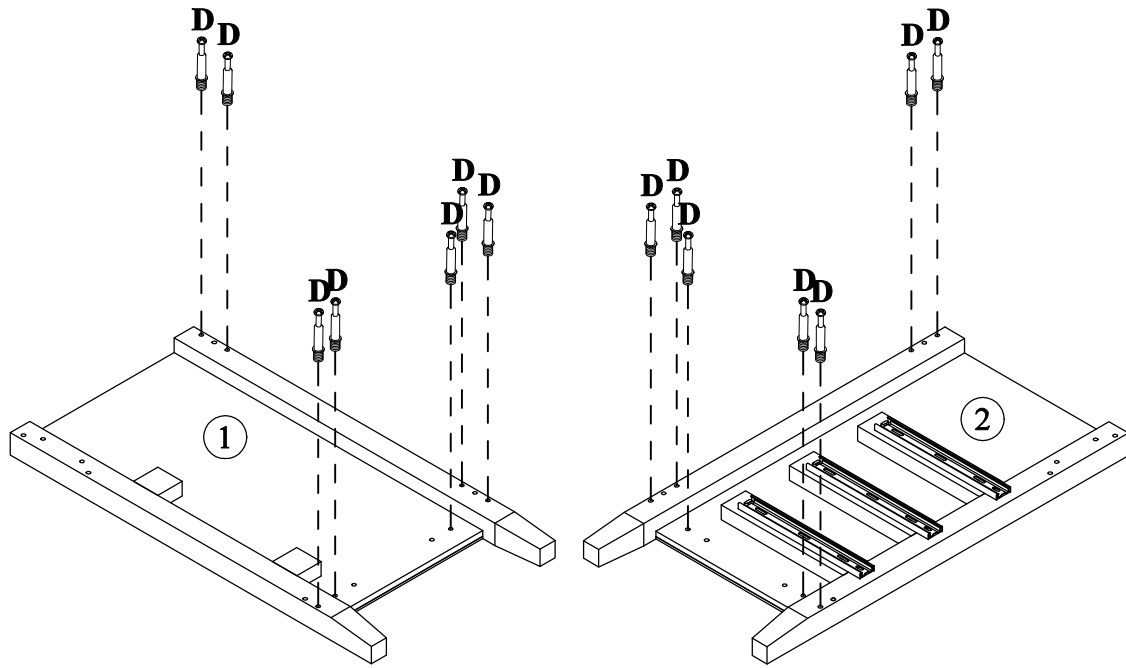

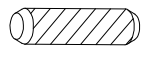

STEP: 2

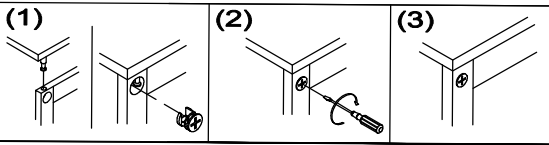
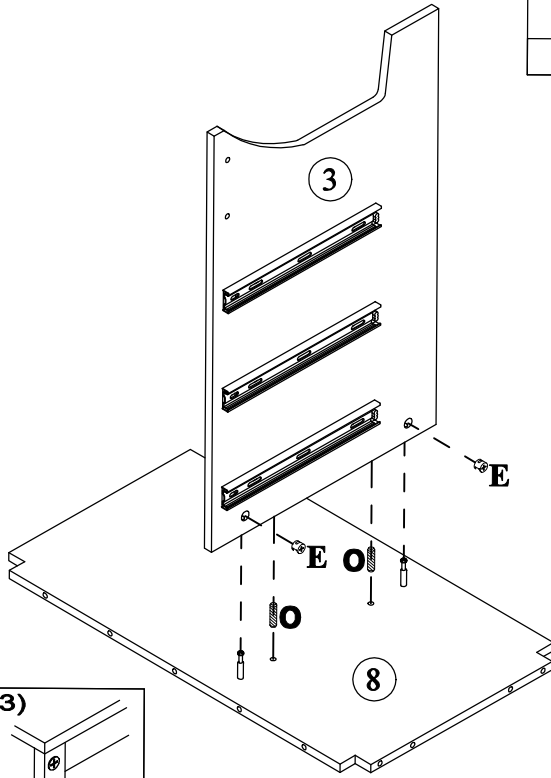
E		O	
	2PCS		2PCS





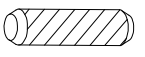

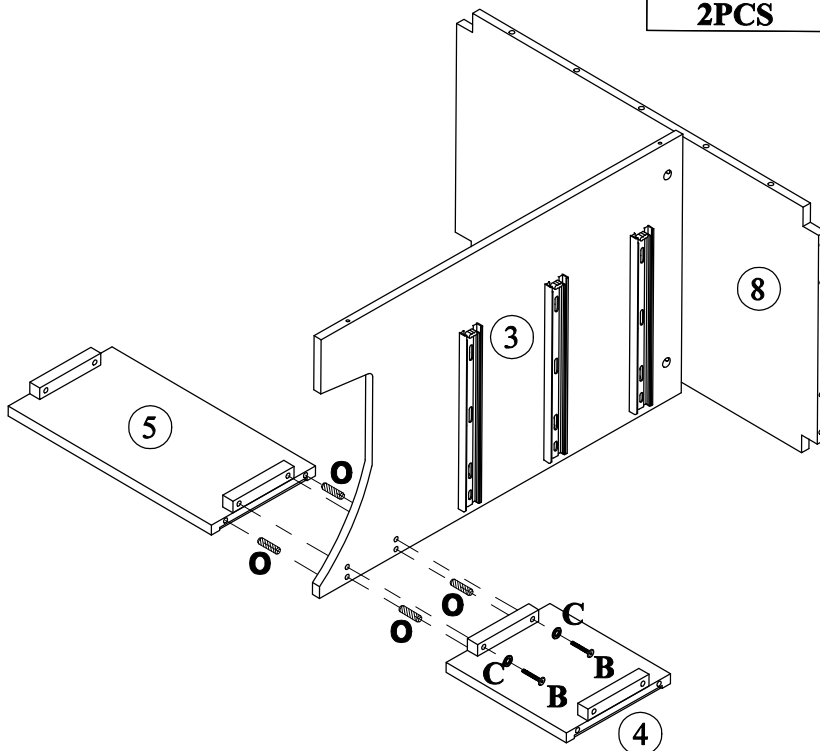
STEP: 3

B		C		O	
	2PCS		2PCS		4PCS

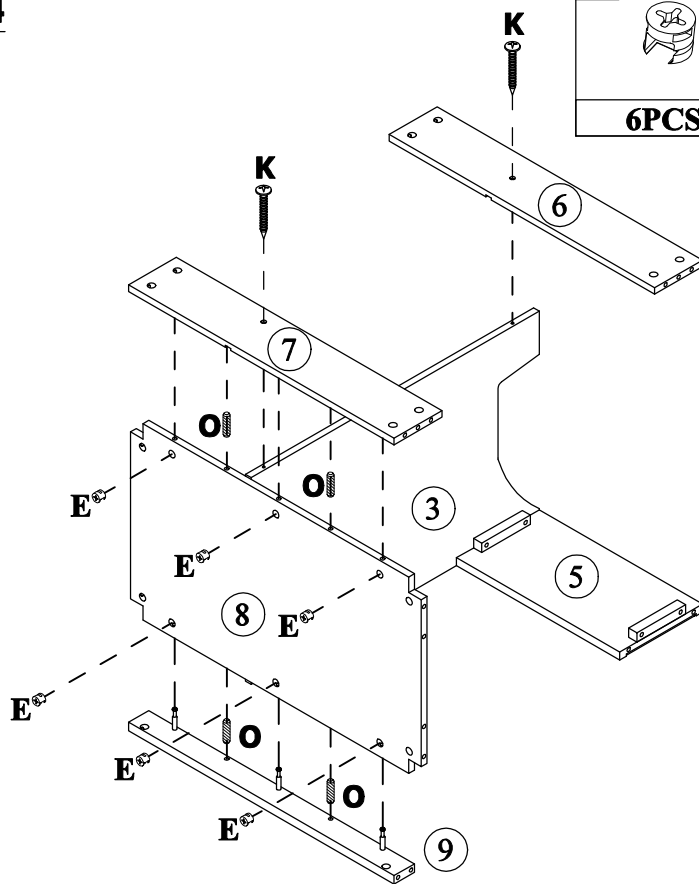

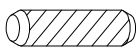

STEP: 4



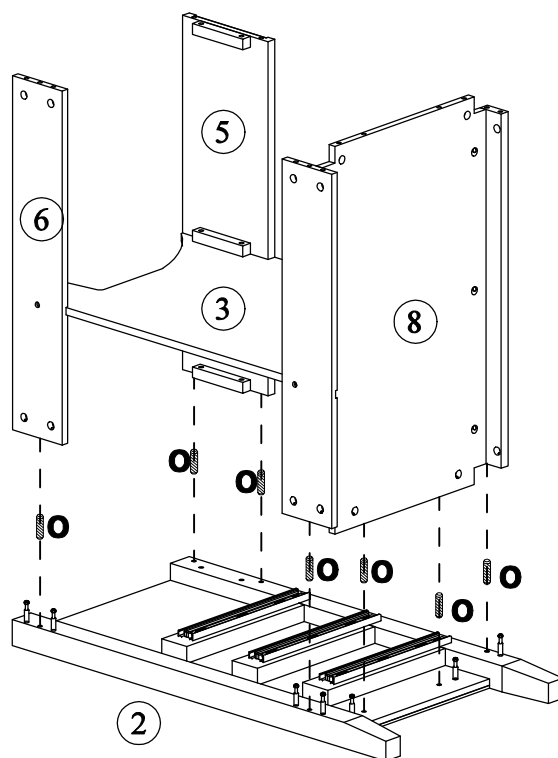

E 	O 	K 
6PCS	4PCS	2PCS

STEP: 5





O 
7PCS

STEP: 6

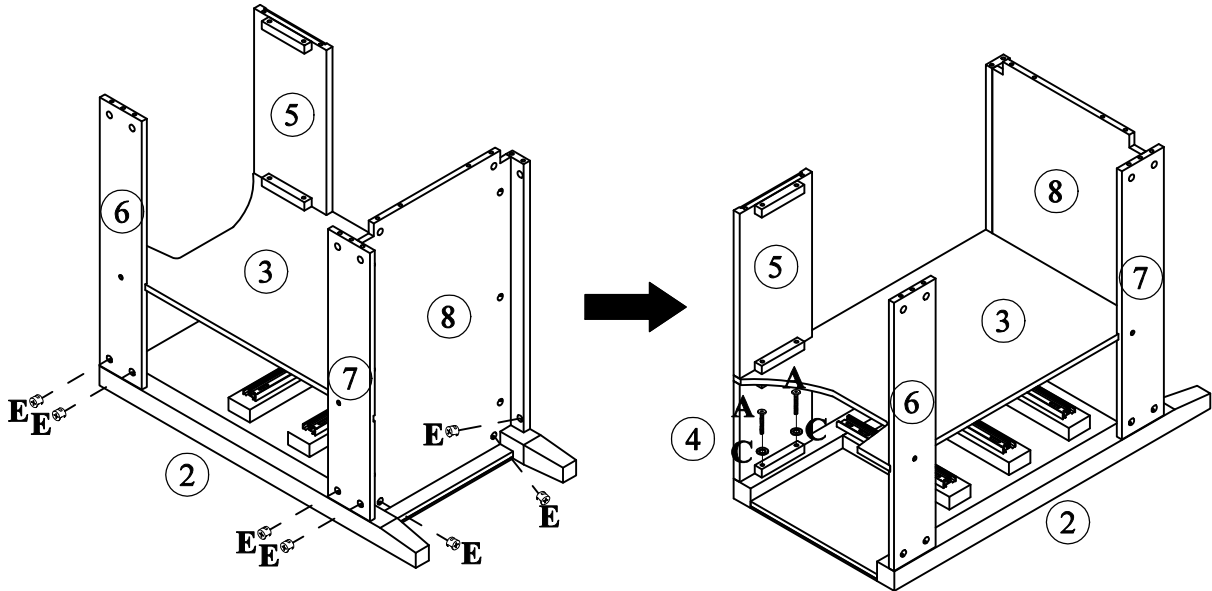
A	C	E
		
2PCS	2PCS	7PCS

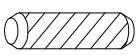

STEP: 7

A	C	E	O
			
2PCS	2PCS	7PCS	7PCS

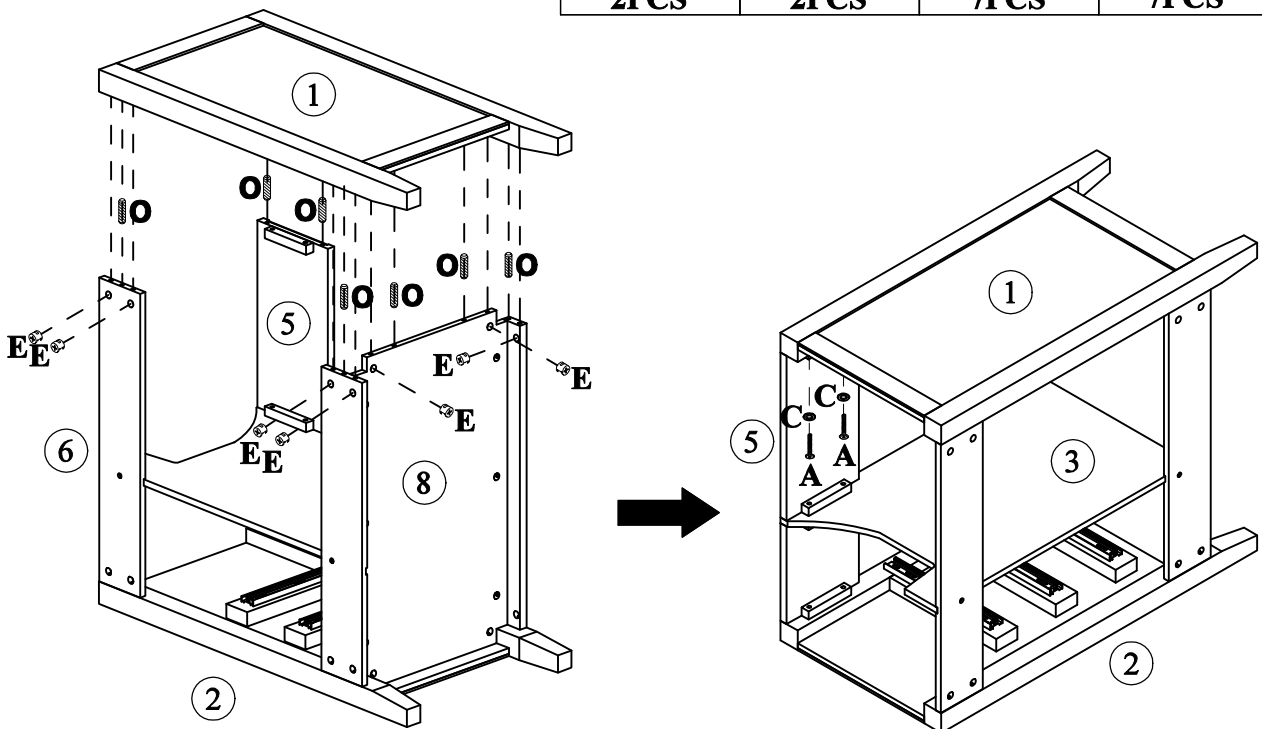

STEP: 8

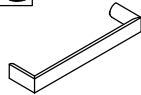
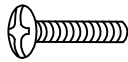
G		I	
2PCS		4PCS	

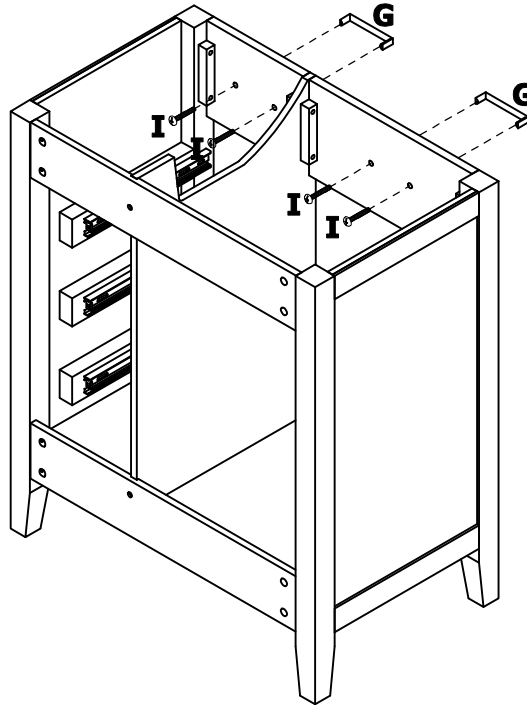

STEP: 9

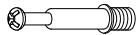
D	
12PCS	

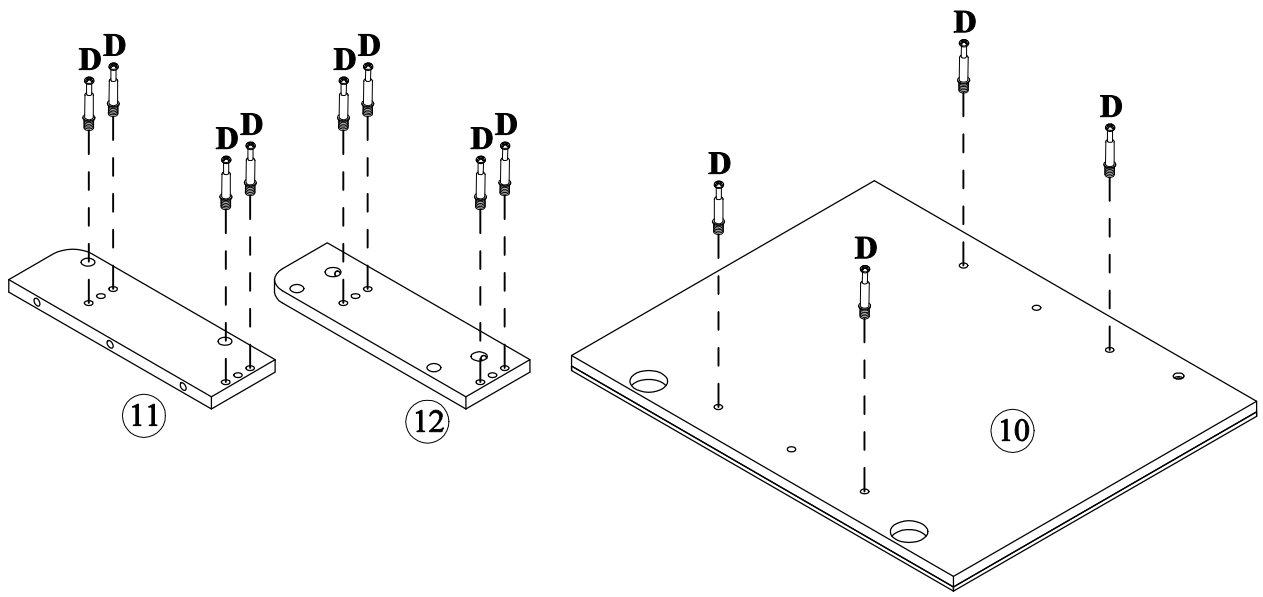

STEP: 10

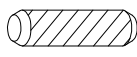
E		O	
	8PCS		4PCS

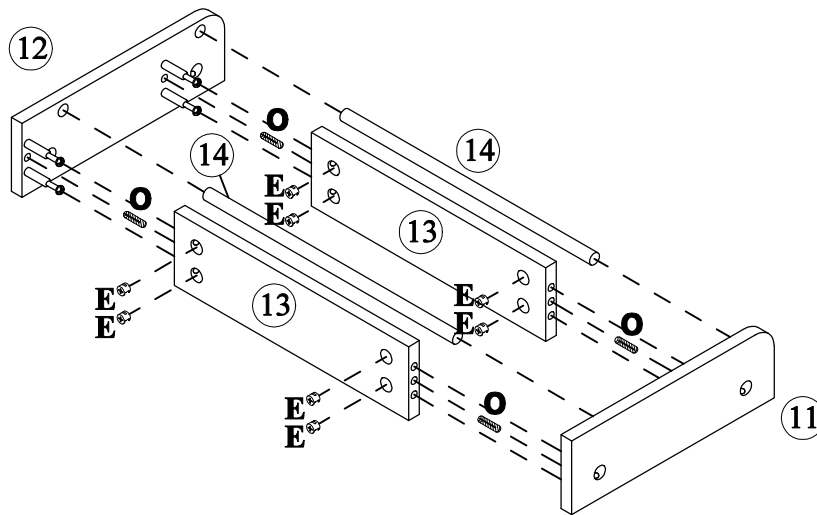

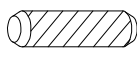

STEP: 11

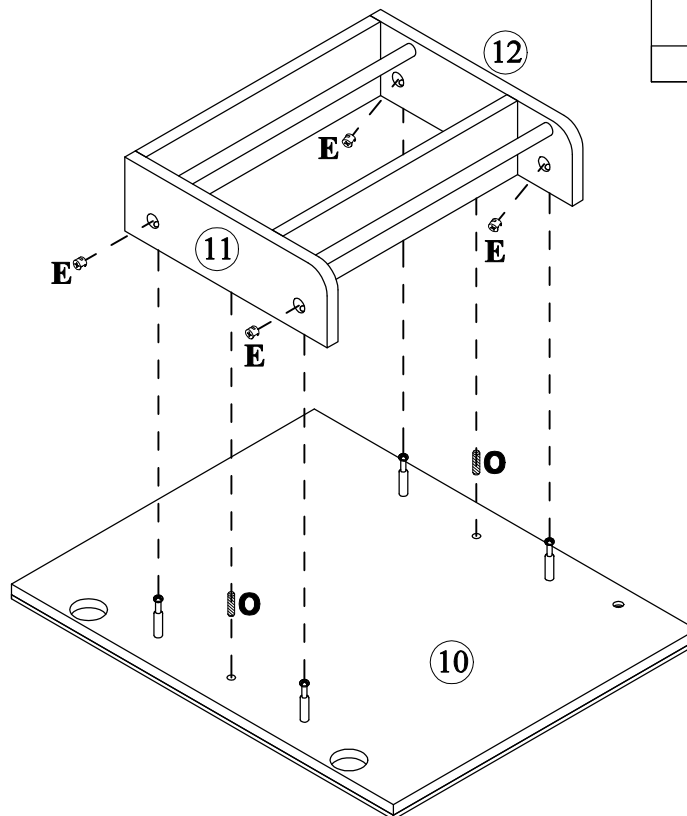
E		O	
	4PCS		2PCS



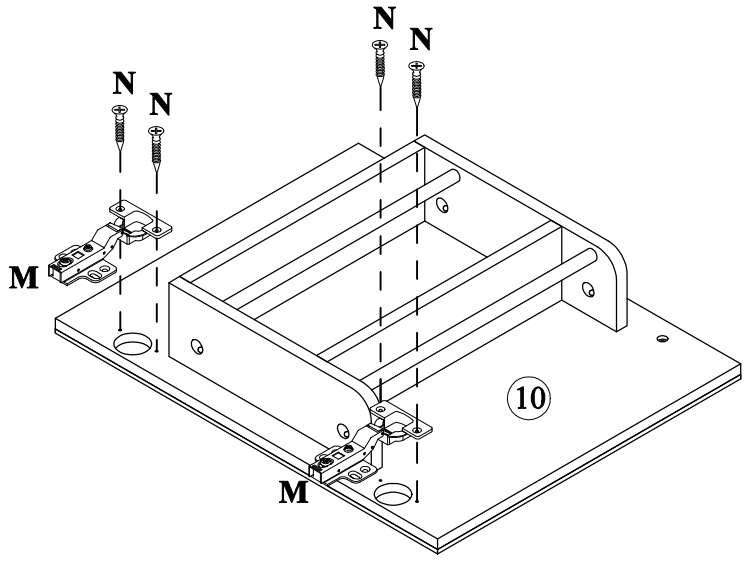

STEP: 12

M		N	
	2PCS		4PCS



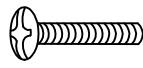

STEP: 13

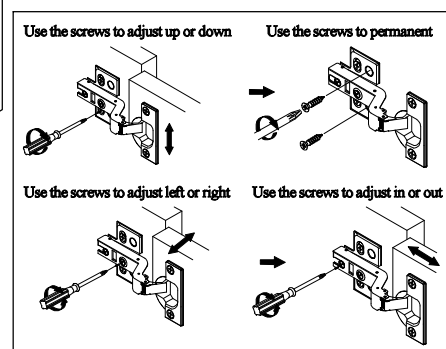
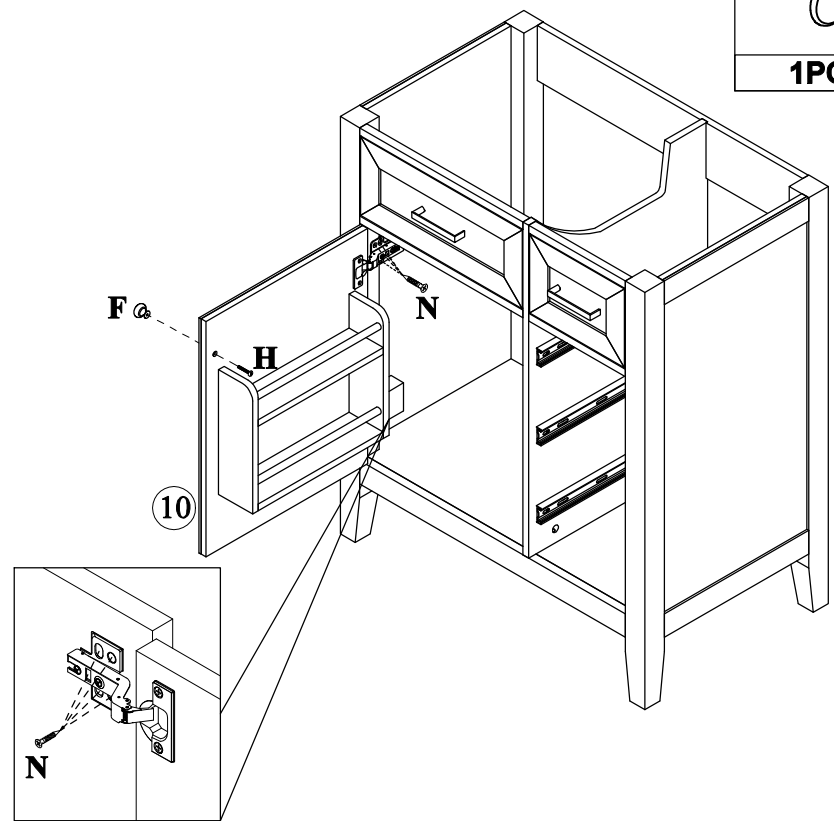
F		H		N	
	1PC		1PC		8PCS

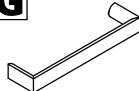
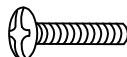

STEP: 14

G 	J 	L 
3PCS	6PCS	24PCS

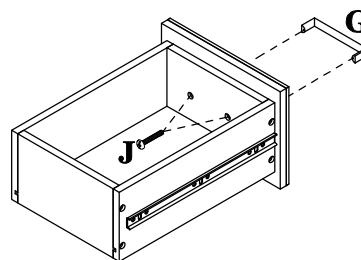
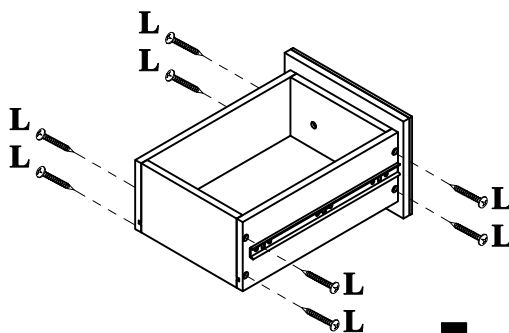
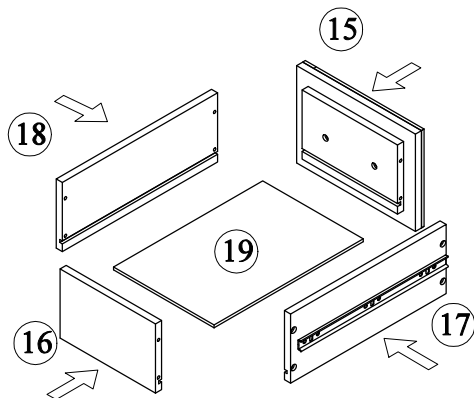

x3

STEP: 15

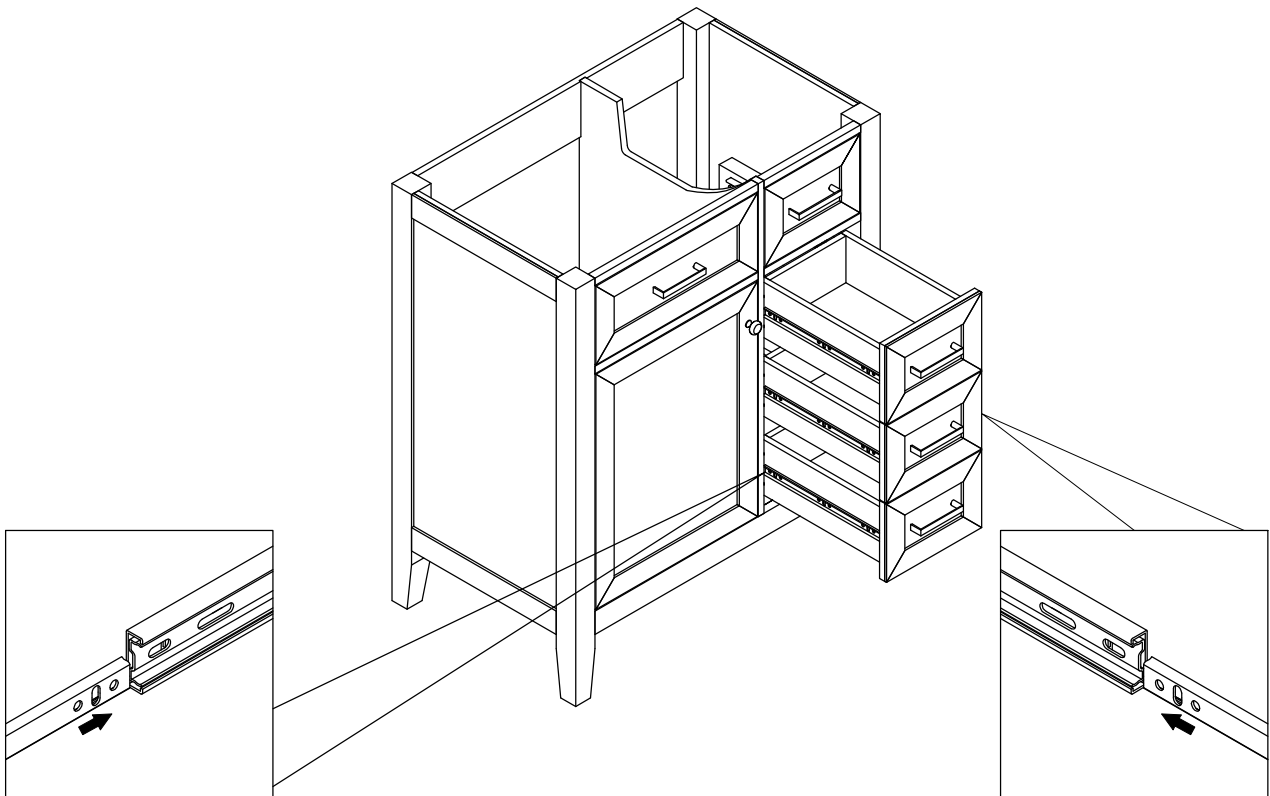

STEP: 16

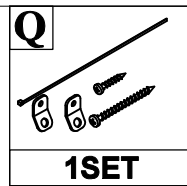
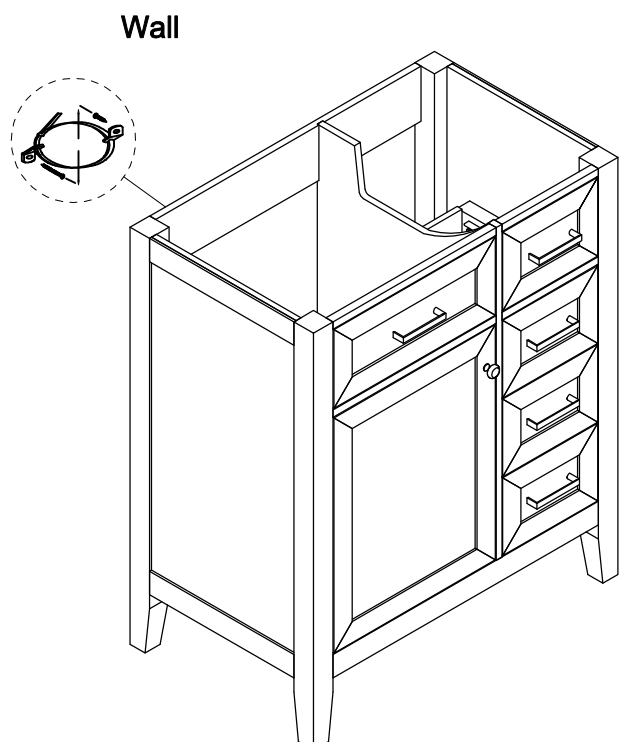

STEP: 17

**Install the sink on the cabinet with glue.
Let stand for 24 hours**

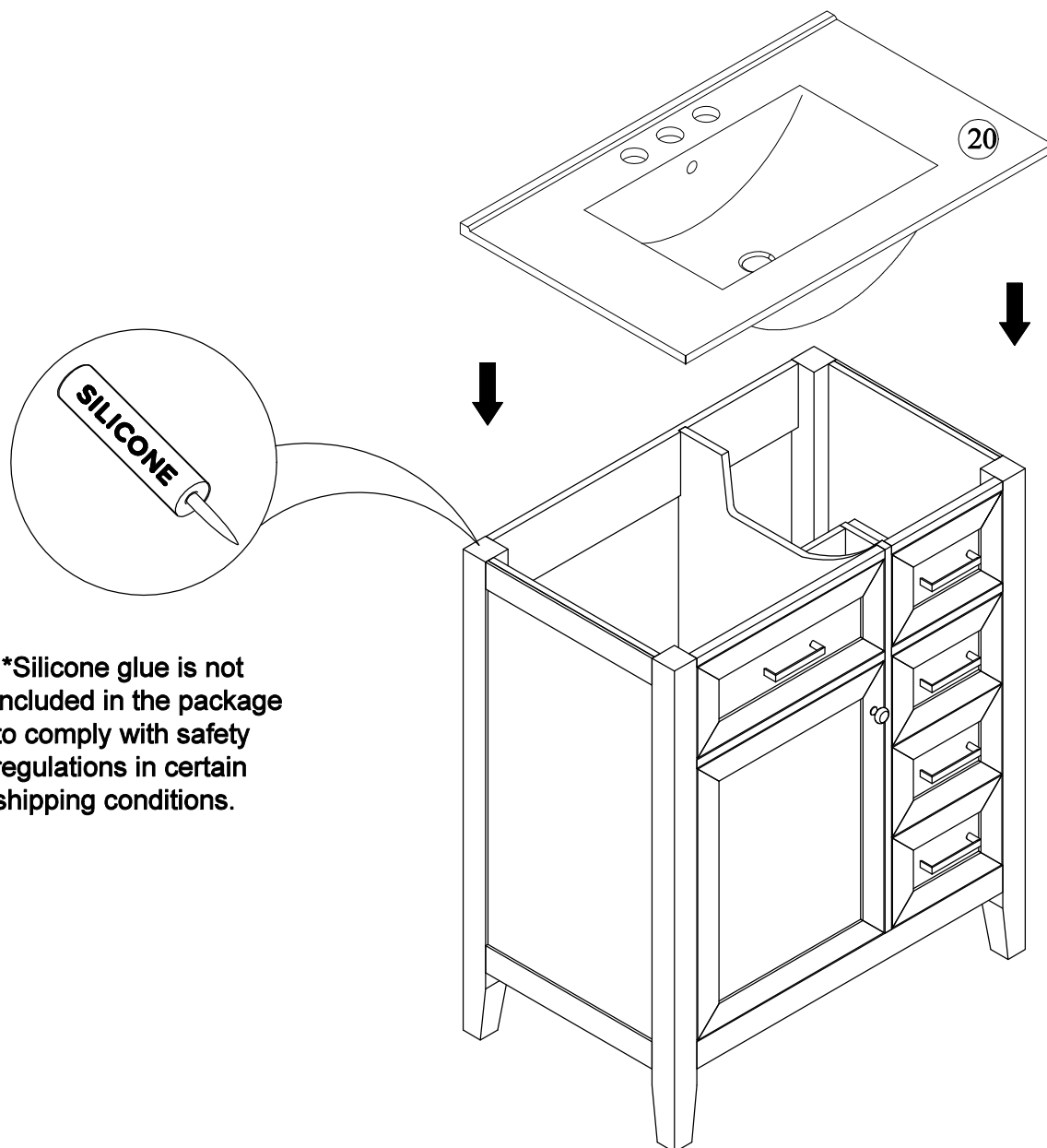

***Silicone glue is not included in the package to comply with safety regulations in certain shipping conditions.**

STEP: 18

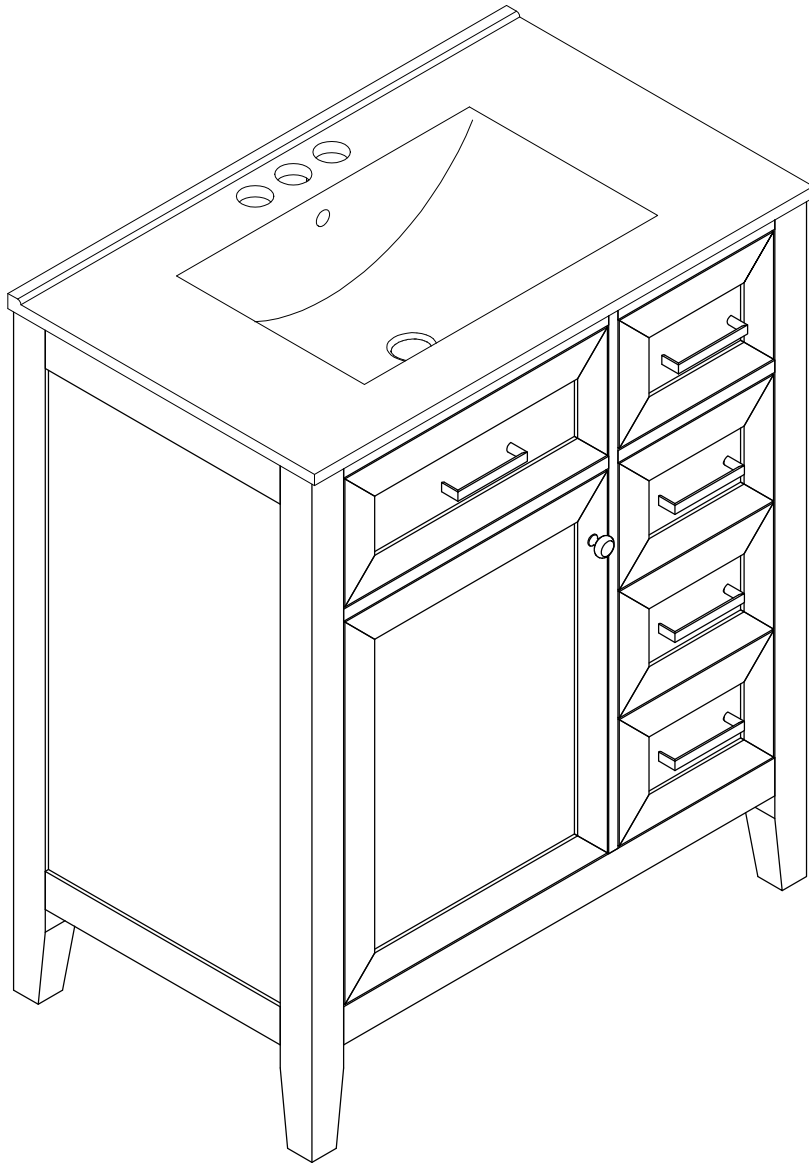

HINGE ADJUSTMENTS



1 Sideways / Tilt adjustment

Turn the screw
clockwise to move the door further away from
the side of the cabinet
anticlockwise to move the door closer to the
side of the cabinet



2 4 Height adjustment

While supporting the weight of the door, turn the
screws
clockwise to move the door up
anticlockwise to move the door down



3 Forward and back adjustment

If the gap between the back of the door and the
cabinet is too small, and the door may not close
fully. Turn the screw
clockwise to decrease the gap between the
door and the cabinet
anticlockwise to increase the gap between the
door and the cabinet

