







1060 E. Springfield Rd.  
High Point, NC 27263  
(336)861-0003

# ASSEMBLY INSTRUCTION

## D-6510-550 RECTANGLE DINING TABLE

**BEFORE YOU START ASSEMBLING ,  
PLEASE MAKE SURE ALL PARTS & HARDWARE ARE INCLUDE IN BOX :**

Assemble the table on a flat surface such as a carpet or cloth to prevent scratching the table finish. Read all instruction and study the drawings carefully before starting the assembly process.

HARDWARE LIST				
A	Allen Bolt		Ø5/16"*2-1/4"	8pcs
B	Lock Washer		Ø5/16"	8pcs
C	Flat Washer		Ø5/16"*19mm	8pcs
D	Allen Wrench		5MM	1pcs

Step 3

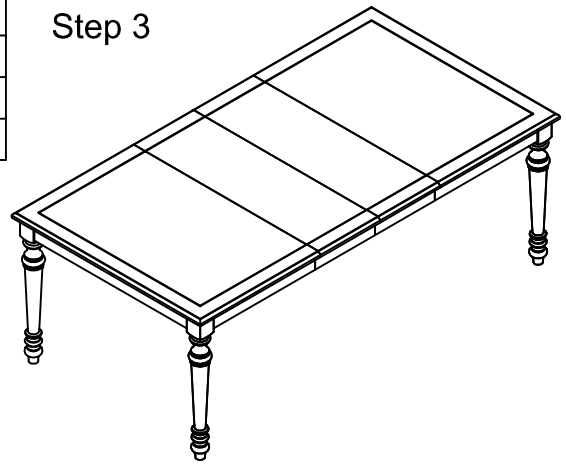

Step 1

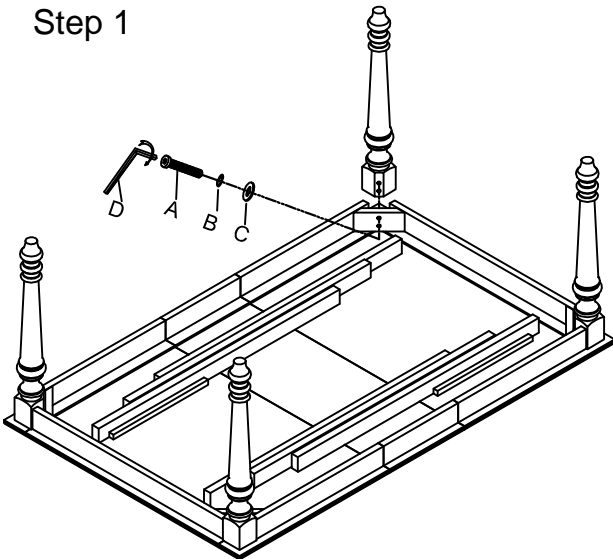

Step 2

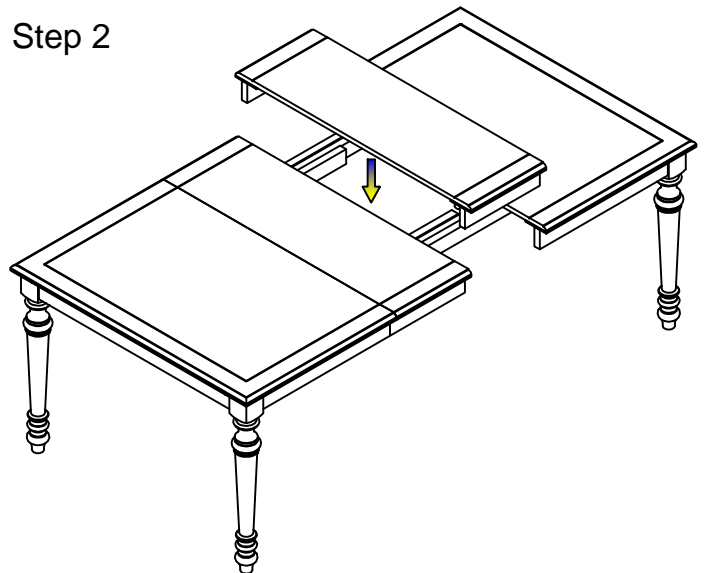

**\*\*Note:**Do not tighten all the bolts and the screws until the table has been put on a flat surface to adjust & level all the legs so that they do not wobble .Once adjusted then tighten all the bolts and the screws but not over-tight the bolts and the screws .

MADE IN CHINA