

ASSEMBLY INSTRUCTION

(BOX 1) BOX OF ARM & SLAT		
B	B1 Arm B2	2 pcs
E	997mm Upper Slat 13 Pcs	1 pc
F	997mm Below Slat 13 Pcs	1 pc
H	Trunder Side	2 pcs
(BOX 2) BOX OF BACK REST & SR		
A	Back Panel	1 pc
C	Side Rail Back Panel	1 pc
D	Side Rail Front Panel	1 pc
G	Trunder Front Panel	1 pc
I	Trunder Back Panel	1 pc
J	Center Rail 1950mm	1 pc
K	Center Rail 1900mm	1 pc
L	Wooden Block	4 pcs
(BOX 1) HARDWARE LIST		
1	M3 x 70mm	1 pc
2	M4 x 65mm	1 pc
3	JCBB M8 X 20	16 pcs
4	JCBC M6 X 60 with Flat Washers	4 pcs
5	Roller	6 pcs
6	CSK M3.5 x 16mm	26 pcs
7	CSK M4 x 25mm	2 pcs
8	CSK M4 x 32mm	32 pcs

Step 1 : Attach side rail (C) & (D) to arm (B) by pushing the bracket down to fit it.

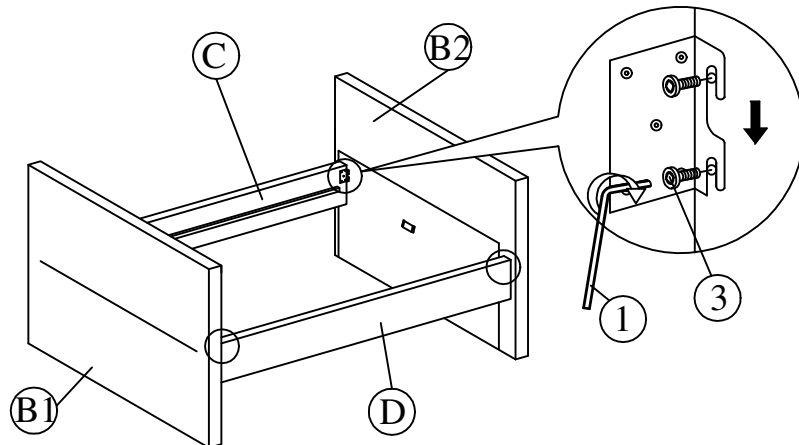

Step 2 : Attach the Back Panel (A) to the arm (B) as shown.

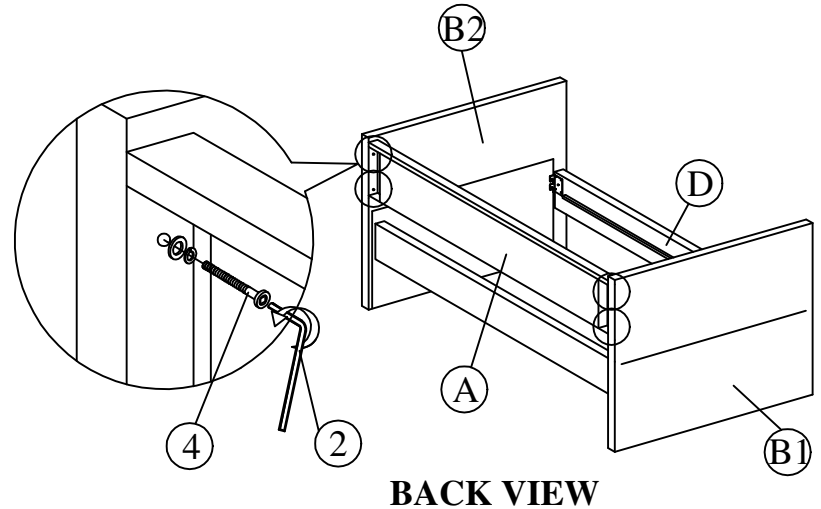

Step 3 : Slide the center rail (J) to the Arm (B). Tighten screws (7) using screw driver (not included) to Arm (B).

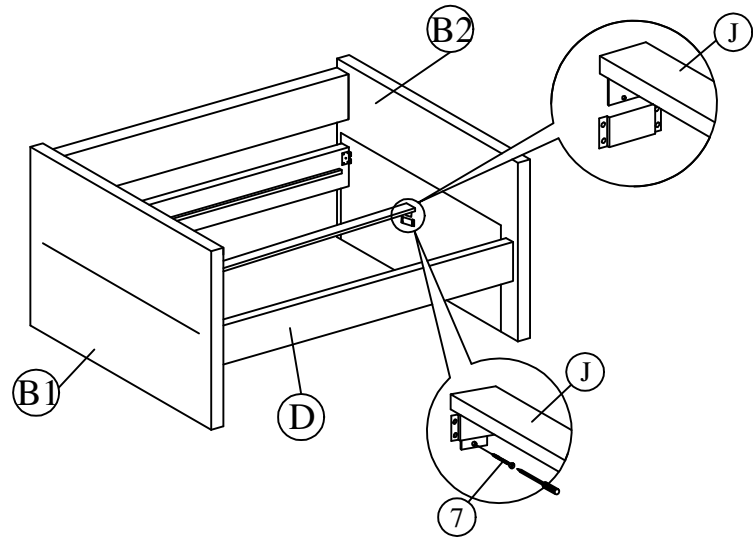

Step 4 : Tighten the 4 Corner with Allen Key (1). Install the slats to side rail. Tighten the slats (E) and center rail (K) with CSK screw (8). The distance of the slats should sufficient to obtain desirable bed stability.

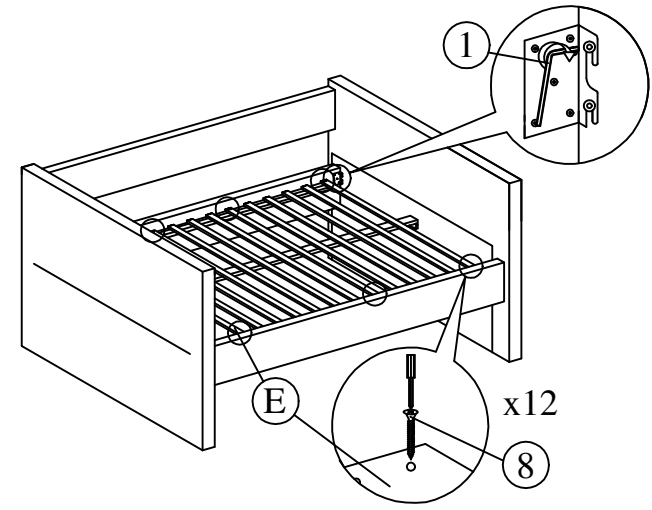

THE HARDWARE IS LOCATED IN THE PACKING ITEMS

Step 5 : Attach trundle side panel (H) and trundle front panel (G) to trundle back panel (I) by pushing the bracket down to fit it.

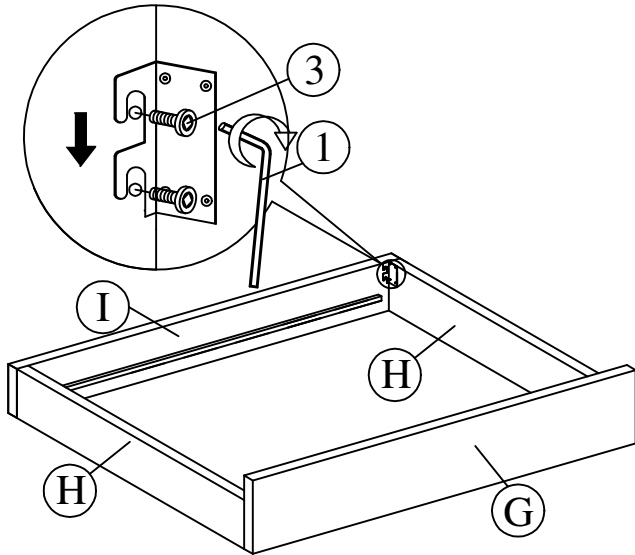

Step 6 : Slide the center rail (K) to the Trunder Side (H). Tighten screws (6) using screwdriver (not included) to the Trunder Side (H).

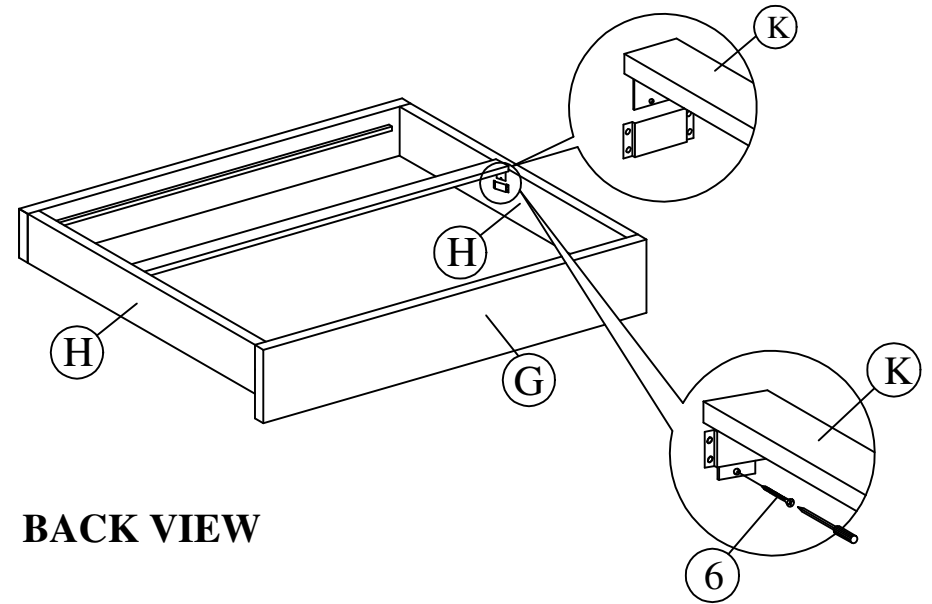

BACK VIEW

Step 7 : Affix the roller (5) to the slat (F) follow the marking on the slat (F).

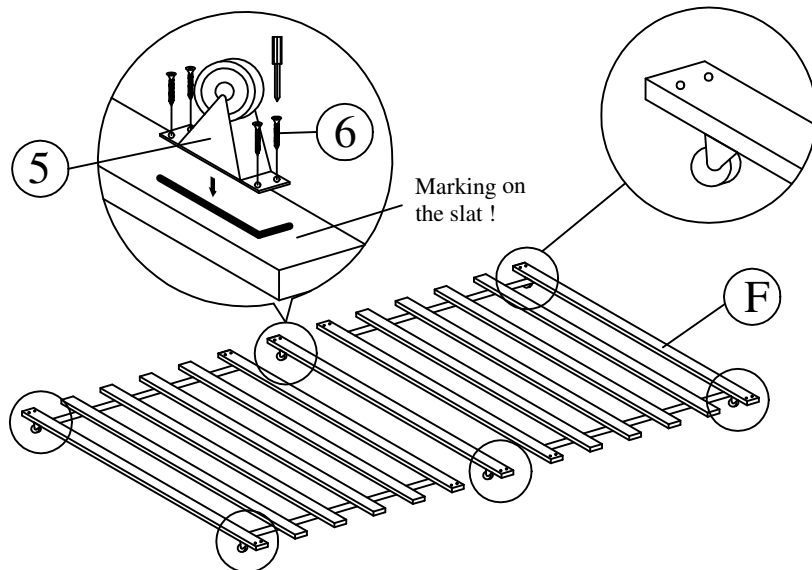

Step 8 : Tighten the 4 Corner with Allen Key (1). Tighten the slat (F) to the trundle at (G) & (I).

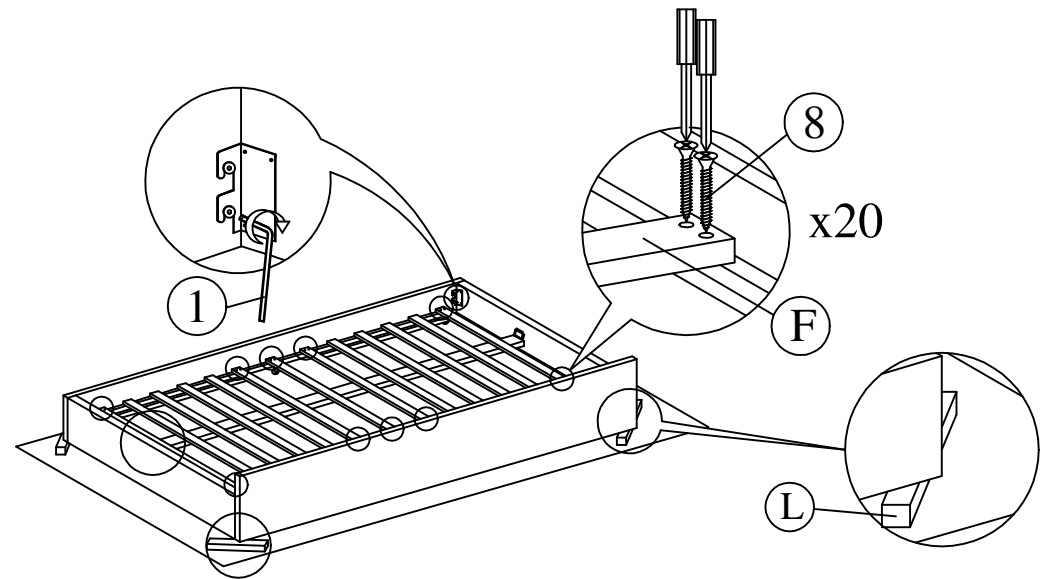

Step 9 : Assembly is complete.

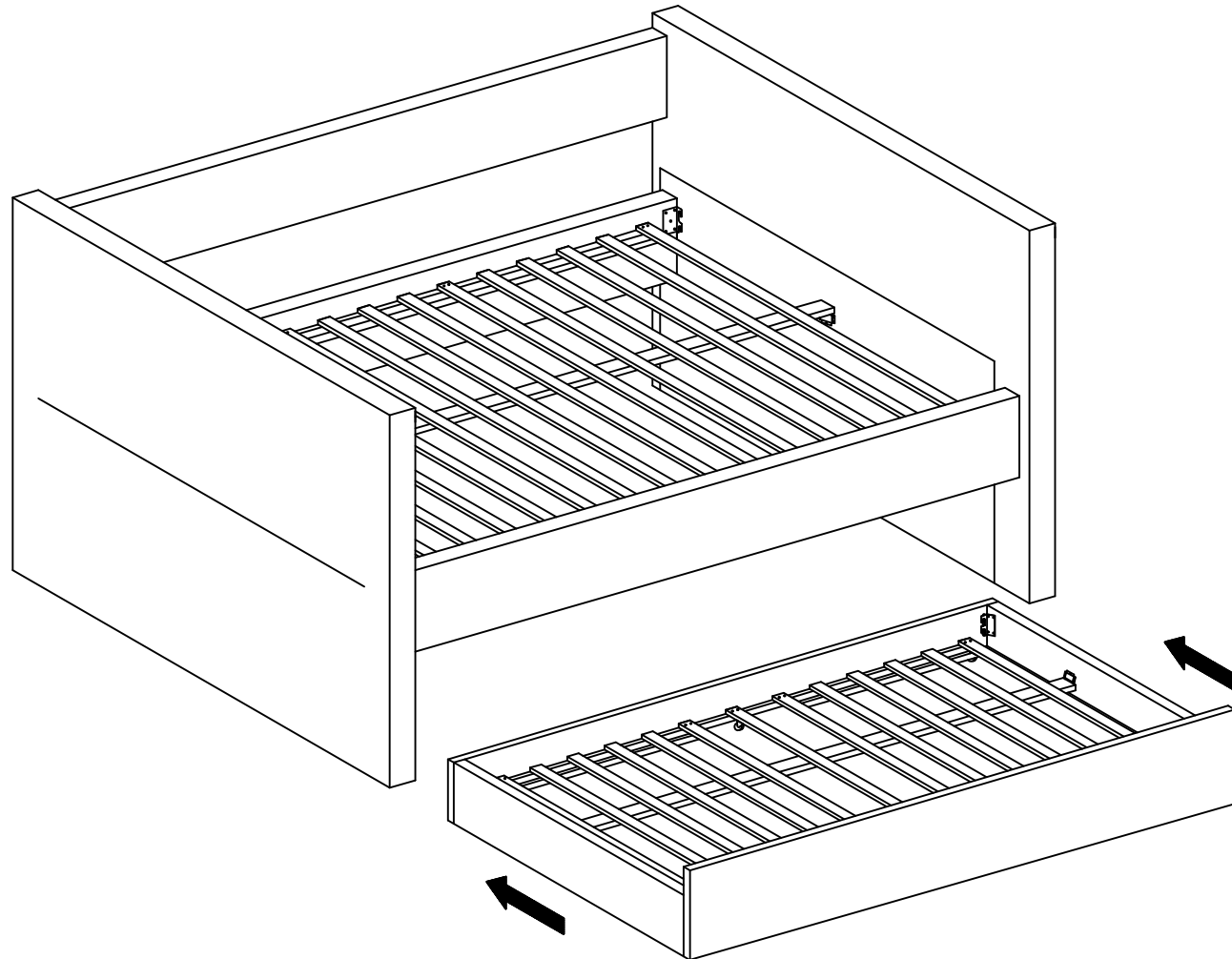

THE HARDWARE IS LOCATED IN THE PACKING ITEMS

PAGE 3 OF 3