

# ASSEMBLY INSTRUCTION

## BAR SET

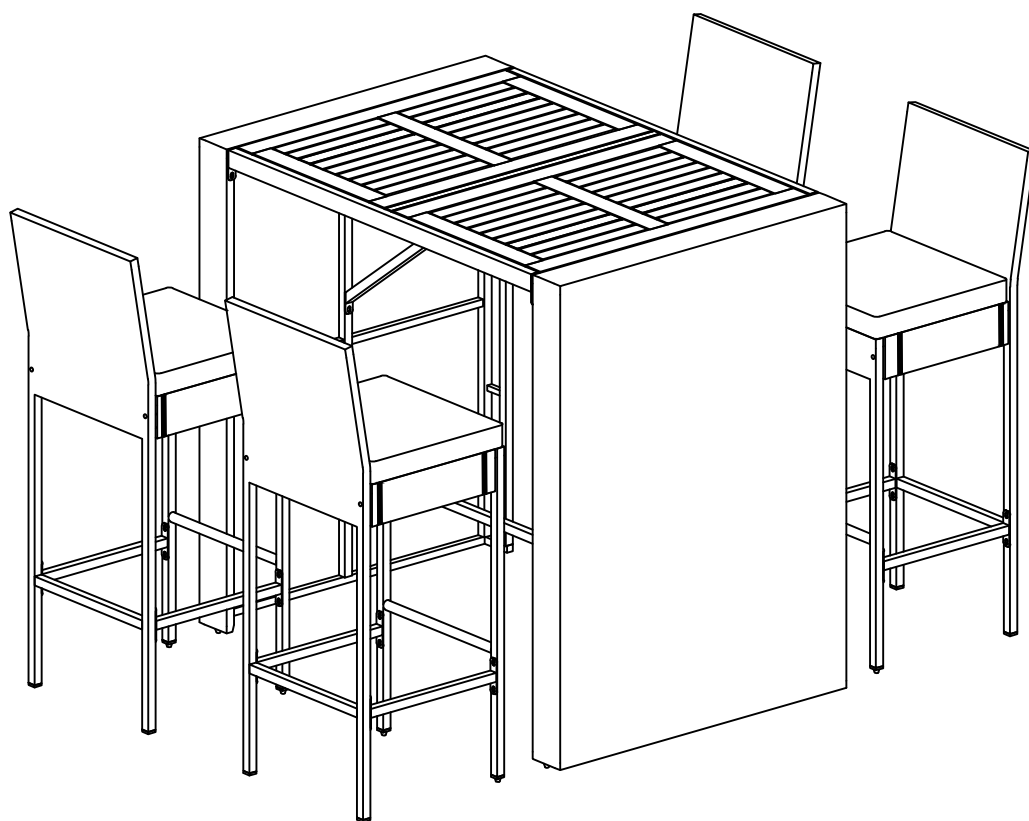

**N704P387909, N704P387910**

**x1**

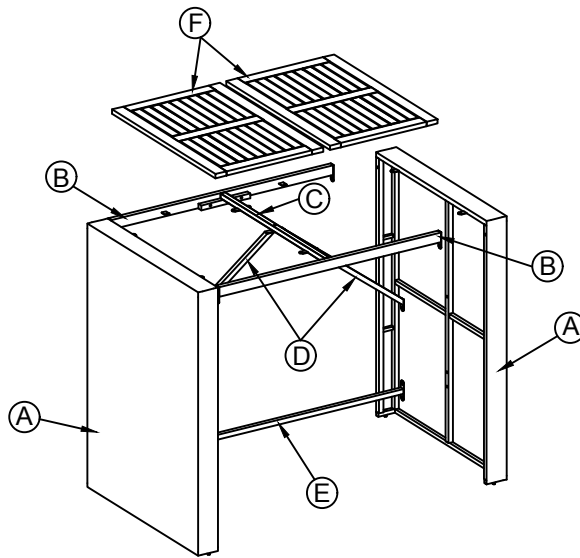

**x4**

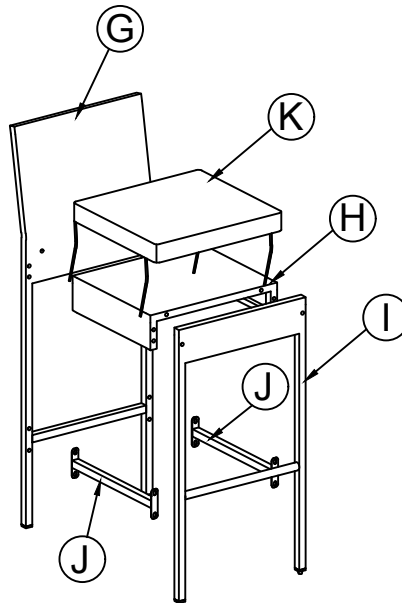

**NOTE:**

1. **50% Tighten before fixing all screws, Allen wrench is recommended instead of an electric drill.**
2. **Place the item on a flat ground to adjust and make sure it remains stable.**
3. **Tighten up all screw with tools gradually.**
4. **If screw are not aligned with holes during assembly, please loosen all the other screws to 50% and continue the assembly process.**
5. **If the item is not stable, please loosen all screws, adjust it on a flat ground and tighten up all screws again.**
6. **Note: If one or some screws are fully tighten during assembly, chances are the others will not be aligned with holes. In addition, all the holes are designed to be relatively larger to provide more space for the adjustment of the screws.**

# CARTON CONTENT:

**N704P387909**

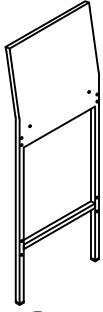

**(G) X4**

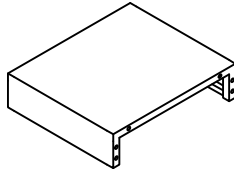

**(H) X2**

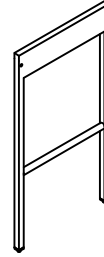

**(I) X2**



**HARDWARE**

**N704P387910**

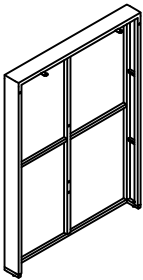

**(A) X2**

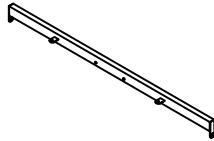

**(B) X2**

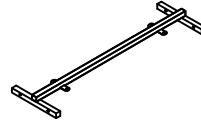

**(C) X1**

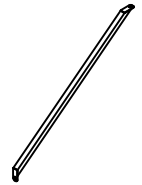

**(D) X2**

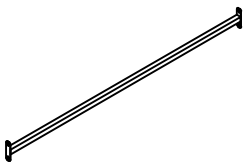

**(E) X1**

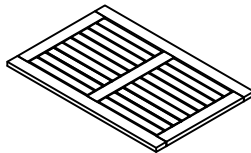

**(F) X2**

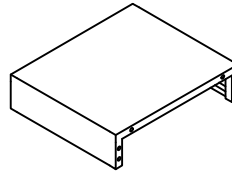

**(H) X2**

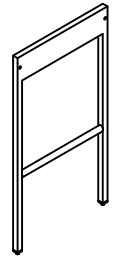

**(I) X2**

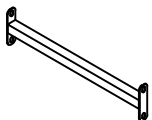

**(J) X8**

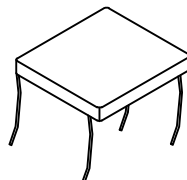





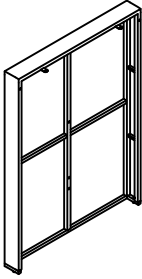
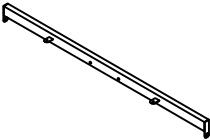
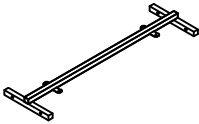
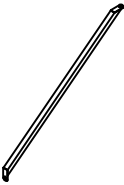
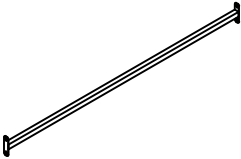
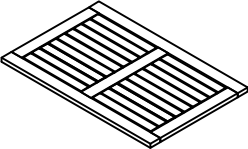
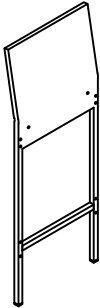
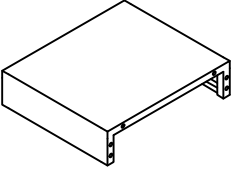
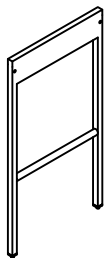
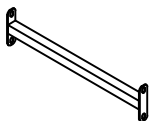
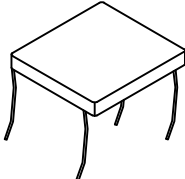

**(K) X4**

# Part List

<p><b>A</b> x2</p>  <p>TABLE LEFT</p>	<p><b>B</b> x2</p>  <p>SUPPORT OF TABLE 1</p>	<p><b>C</b> x1</p>  <p>SUPPORT OF TABLE 2</p>	<p><b>D</b> x2</p>  <p>SUPPORT OF TABLE 3</p>
<p><b>E</b> x1</p>  <p>SUPPORT OF TABLE 4</p>	<p><b>F</b> x2</p>  <p>TABLE TOP</p>	<p><b>G</b> x4</p>  <p>BACK LEG</p>	<p><b>H</b> x4</p>  <p>SEAT CHAIR</p>
<p><b>I</b> x4</p>  <p>FRONT LEG</p>	<p><b>J</b> x8</p>  <p>SUPPORT OF CHAIR</p>	<p><b>K</b> x4</p>  <p>SEAT CUSHION</p>	

## Hardware

<p>① x43 pcs Extra 2 pcs</p>  <p>BOLT M6 X 20MM</p>	<p>③ x95 pcs Extra 4 pcs</p>  <p>WASHER M6</p>	<p>⑤ x4 pcs Extra 1 pc</p>  <p>ADJUSTABLE FEET</p>	<p>⑦ x1 pc</p>  <p>SCREWDRIVER</p>
<p>② x52 pcs Extra 2 pcs</p>  <p>BOLT M6 X 40MM</p>	<p>④ x12 pcs Extra 2 pcs</p>  <p>SCREW M4 x 15MM</p>	<p>⑥ x2 pcs</p>  <p>ALLEN KEY</p>	

# STEP 1

- ① X4
- ③ X4
- Ⓐ X2
- Ⓑ X2

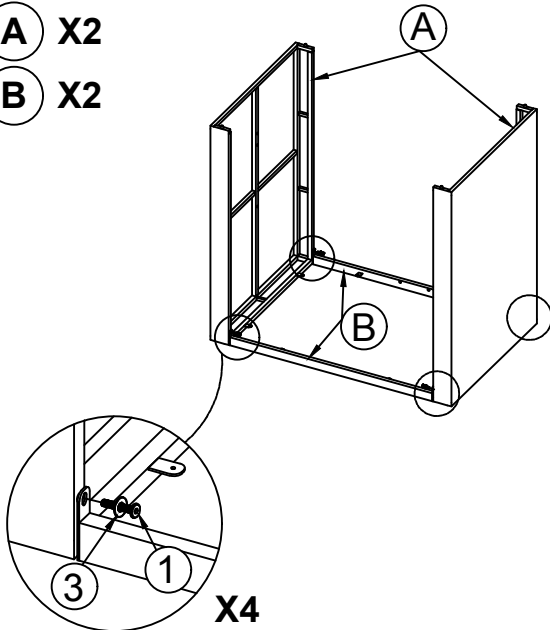
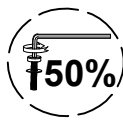

# STEP 2

- ② X4
- ③ X4
- Ⓒ X1

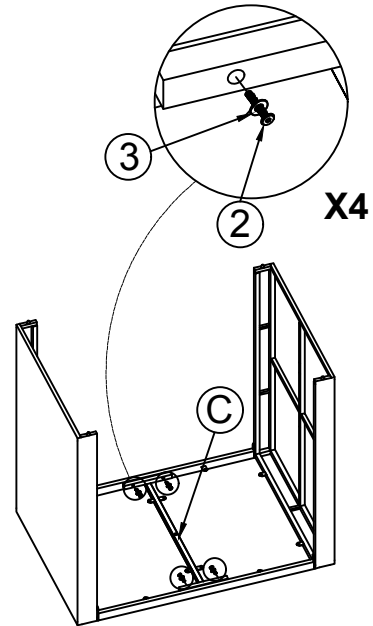

Connect Table Left (A) & Support (B) with Bolt (1) & Washer (3).

Connect part from STEP 1 & Support (C) with Bolt (2) & Washer (3).

# STEP 3

- ① X7
- ③ X7
- Ⓓ X2
- Ⓔ X1

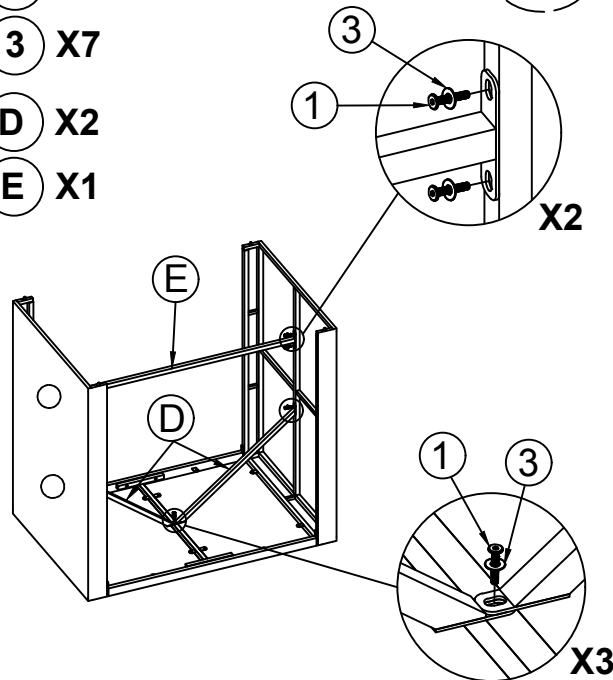
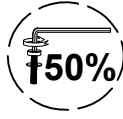

# STEP 4

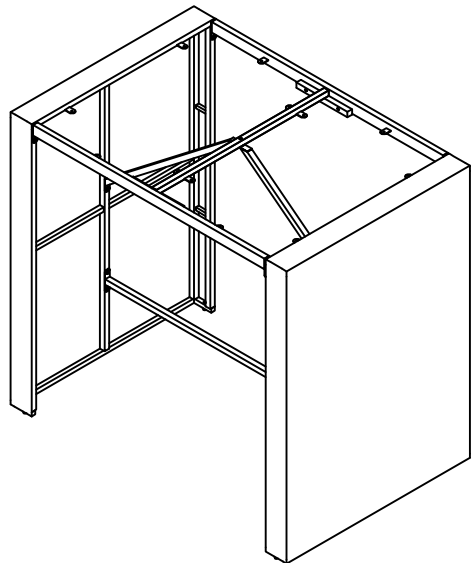

Connect part from STEP 2 & Support (D),(E) with Bolt (1) & Washer (3).

100 % Tighten

## STEP 5

5 X4

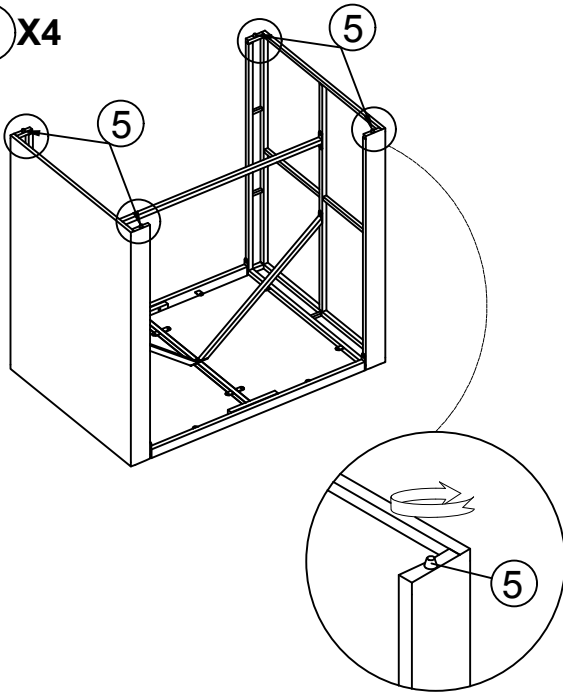

## STEP 6

F X2

4 X12

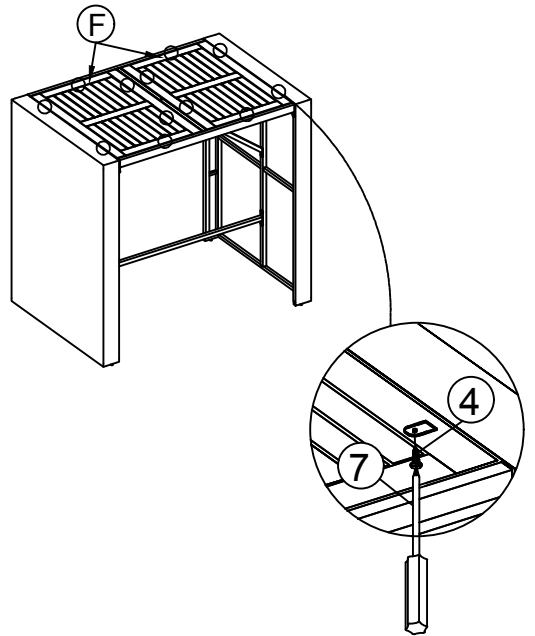
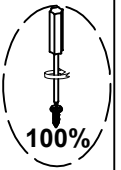

Connect part from STEP 4 & Adjustable Feet (5) by Hand.

Connect part from STEP 5 & Table Top (F) with Screw .

## STEP 7

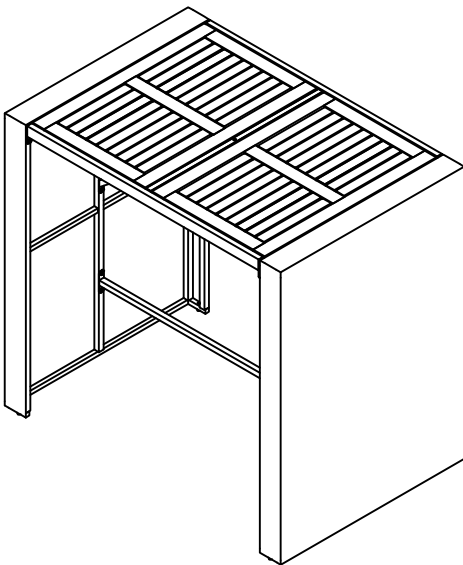

## STEP 8

2 X4

3 X4

G X1

H X1

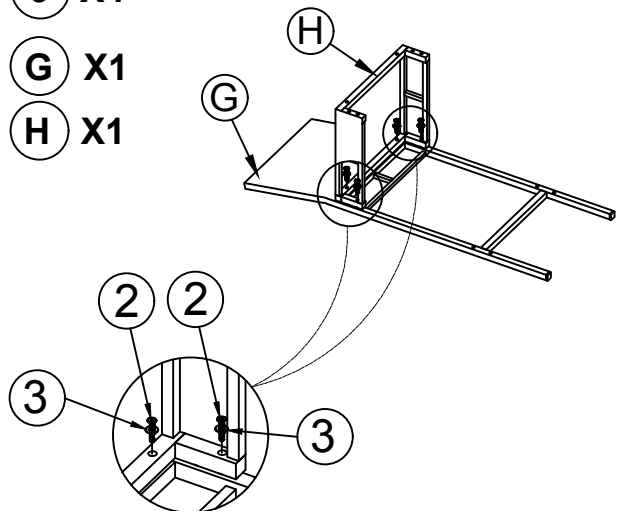

Complete Table.

Connect Back Leg (G) & Seat (H) with Bolt (2) & Washer (3).

## STEP 9

2 X6

3 X6

I X1

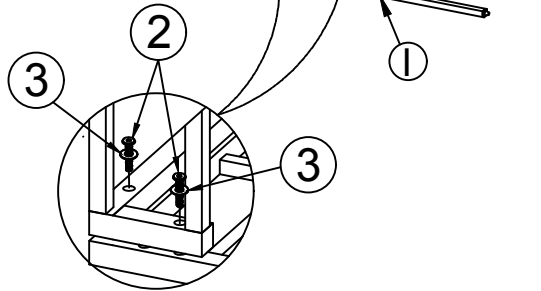

Connect part from STEP 8 & Front Leg (I), Back Leg (G) with Bolt (2) & Washer (3).

## STEP 10

2 X2

3 X2

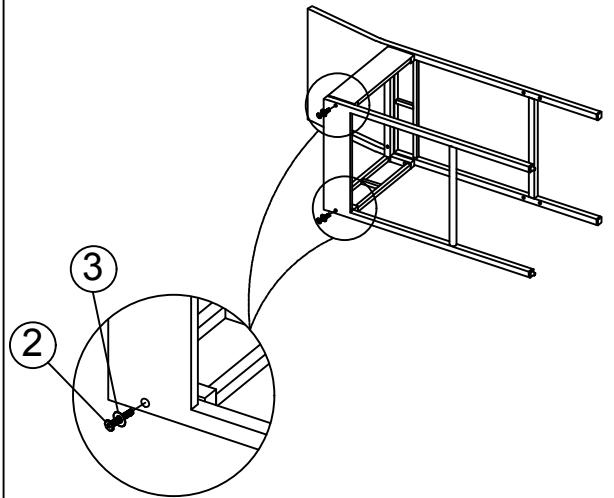

Connect part from STEP 9 & Front Leg (I) with Bolt (2) & Washer (3).

## STEP 11

1 X8

3 X8

J X2

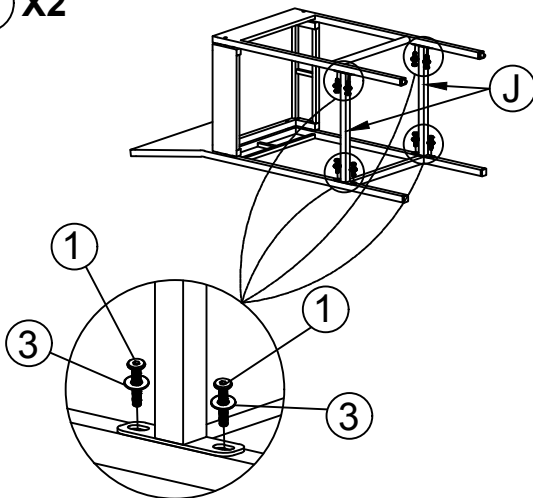

Connect part from STEP 10 & Support of Chair (J) with Bolt (1) & Washer (3).

## STEP 12

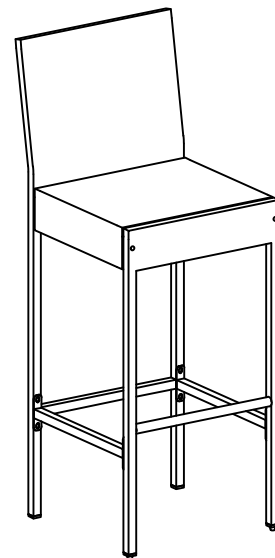

X4

100 % Tighten

# STEP 13

(K) X1

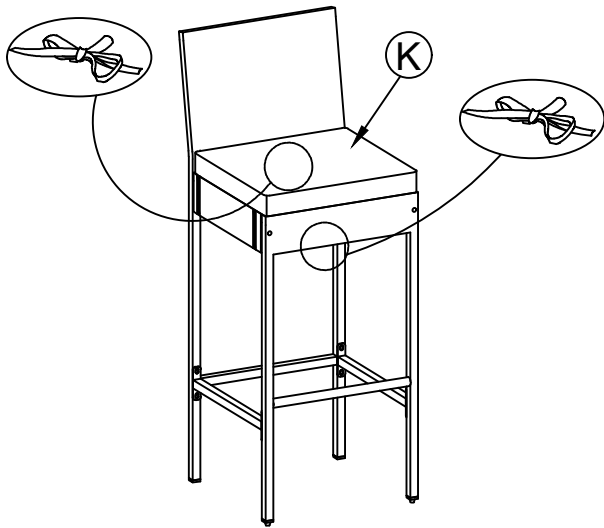

X4

Put the Seat Cushion (K) on to complete the Chair.

# FINISH

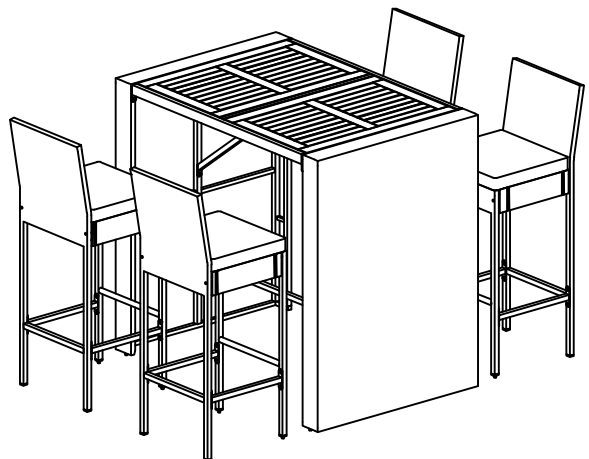
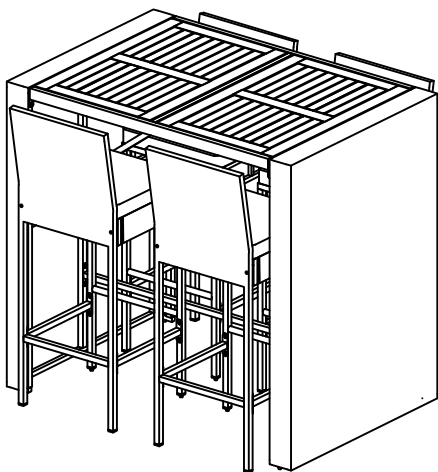

**INSTRUCTIONS FOR USE:**

1. Never force the connections. Re-tighten the screws after few days.
2. Keep the Instructions AI leaflet, it contains information when claiming for missing parts.
3. Ensure to not exceed the maximum loading weight for a safe usage. Avoid jumping on or applying excessive pressure to the product to prevent structural damage.
4. Do not move loaded furniture.
5. Wood is a natural material, each piece of wood is unique. It is therefore normal that its appearance shows variations in colour and appearance.
6. Exposed to the sun, the wood will naturally turn gray over time and, in the more or less long term, depending on the exposure conditions, present micro-cracks which will not jeopardize the solidity of the product.

**STORAGE AND CLEANING:**

1. Outdoor furniture can be cleaned with soap and water. Rinse the furniture with clean water.
2. Always store the dry and clean product at room temperature. If the product becomes wet, allow it to dry thoroughly in a dry, well-ventilated area before using it again.
3. Do not cover hermetically the product, this way locks the humidity and can cause stains and wood deformation.
4. For any specific maintenance or renovation product, check the compatibility of the products you apply with the support to be maintained.
5. Refer to the instructions for use of the maintenance product.
6. Use a furniture cover whenever possible to protect it from the elements and dirt.
7. Clean fabric outdoor furniture using washine machine with gentle cycle.
8. To avoid shrinkage, stretch back over the frame before the fabric is completely dry.
9. If the steel isn't stainless, wipe it carefully to avoid rust.
10. Keep away from open flames or hot objects to avoid fire hazards.
11. Keep children and pets away from sharp parts of the product to prevent potential injuries.