

# ASSEMBLY INSTRUCTION

## BENCH

**A** Bench

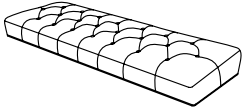

1pc

**B** Leg  
(Underneath the bench)



4pcs

**C** Lock Washer  
5/16"



12pcs

**D** Flat Washer  
5/16"



12pcs

**E** Allen Wrench  
5/16"



1pc

**F** Bolt  
5/16"\*1-1/4"

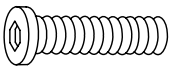

12pcs

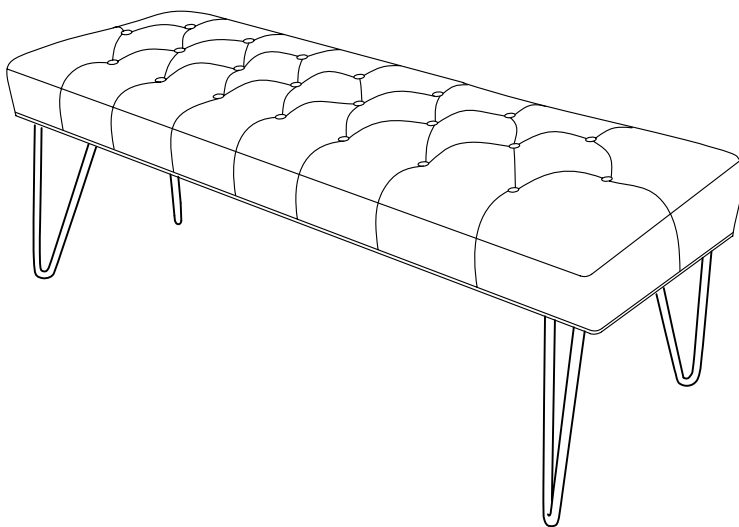

This page lists all the contents included in the box. Please take the time to identify the hardware as well as the individual components to this product. As you unpack and prepare for assembly, place the contents on a carpeted or padded area to protect them from damage.

1

Put the bench(A) on a smooth flat surface, then open the bottom cloth and take out the leg box.

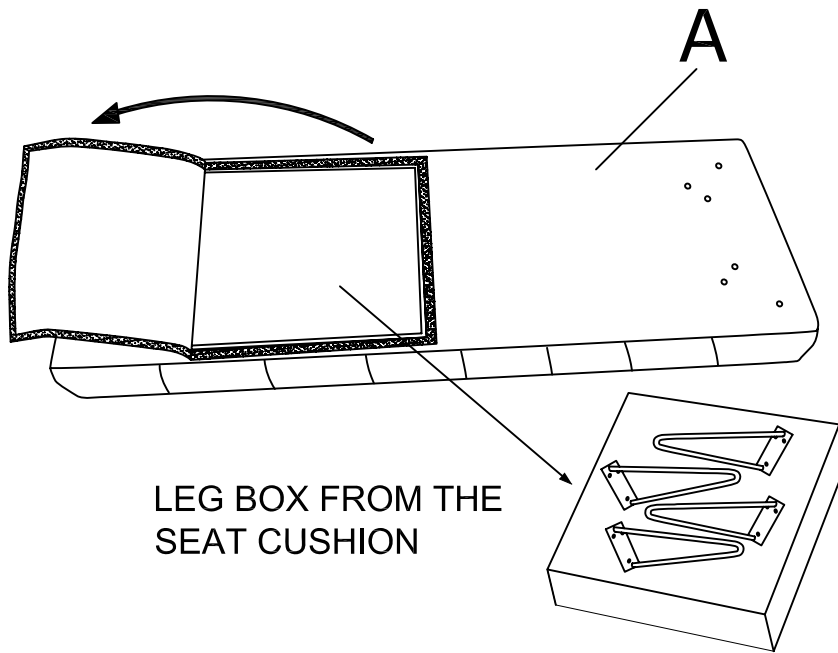

2

Put the bench(A) on a smooth flat surface, attached one leg(B) to the bench(A) use bolt(F), lock washer(C) and flat washer(D) on both of hole of bench(A). Turn the allen wrench(E) in bolt(F). But not too tight.

Take the Allen Wrench, and turn the bolts until the legs are secure. DO NOT TIGHTEN COMPLETELY. Stop when you feel you are adding force to tighten the bolt.

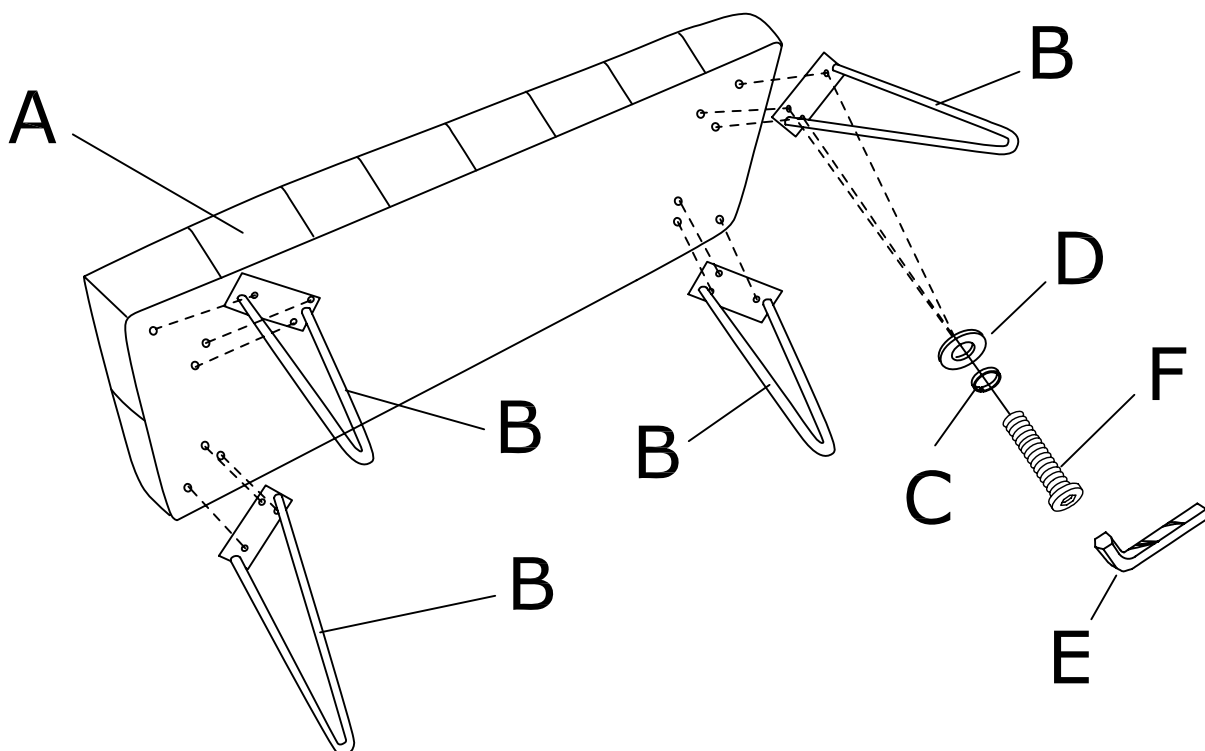

---

**3**

Turn the bench over.

Stand bench up on an even surface and check that it is balanced. If there is a slight wobble, apply downward pressure in the corner where a leg is uneven. Keeping pressure in that corner, tighten all bolts. If balanced, apply downward pressure evenly in the center and tighten all bolts. Do not over-tighten beyond hole depth.

**Helpful Tip:**

-Instead of applying downward pressure while reaching under to tighten bolts, have someone sit in the bench while you tighten the bolts.

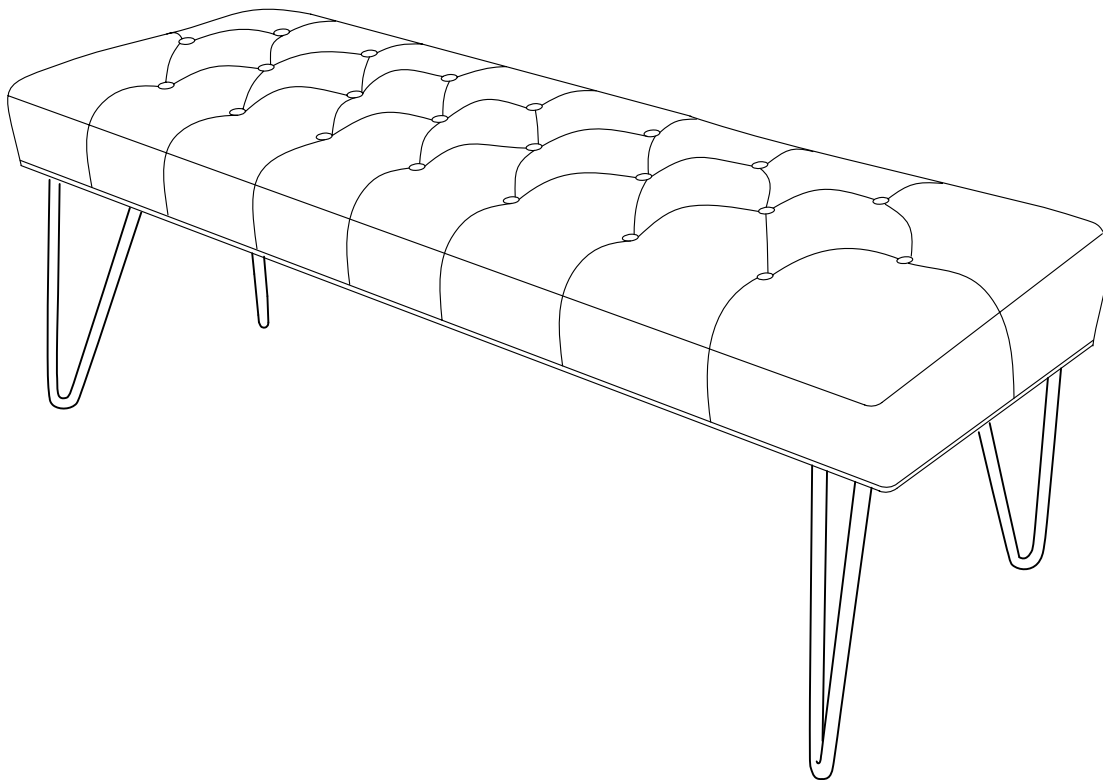

---

### **Cleaning & Care**

Treat surface with care. Surface is resistant to scratches but is not scratch resistant. Clean surfaces with a dry or damp soft cloth. Do not use abrasive cleaners. Hardware may loosen over time. Periodically check that all connections are tight.