

200CPU Holder Assembly Instructions
Warranty: raproducts.com/warranty

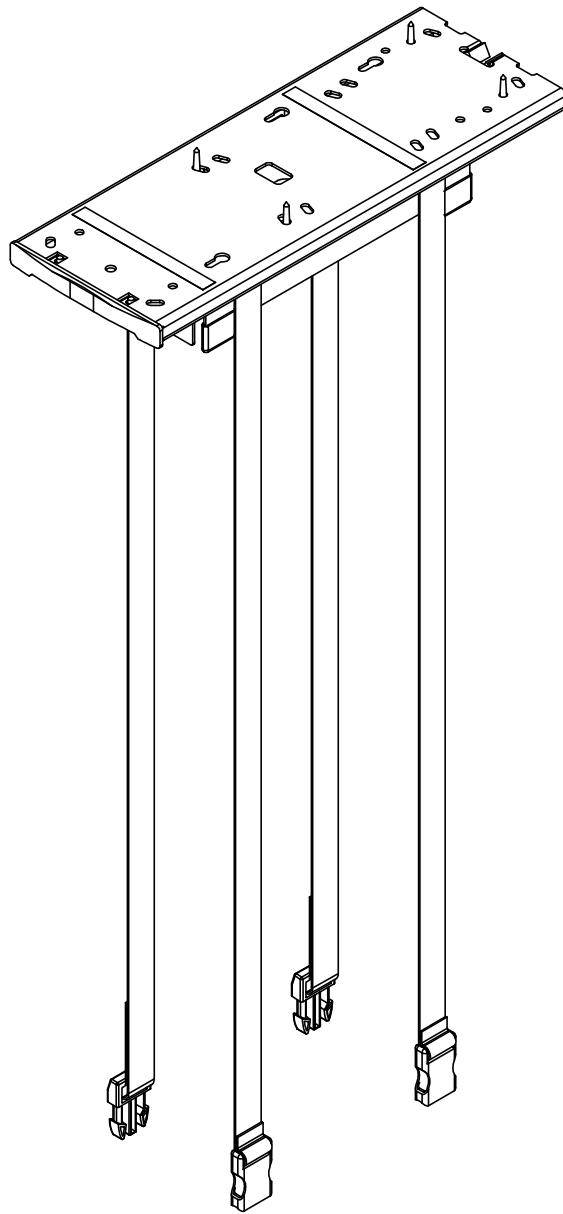

Tools Required for Assembly



Power Driver with Adjustable Torque



#2 Phillips Head Driver Bit

Or



#2 Square Head Driver Bit

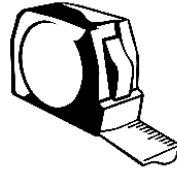

Tape Measure

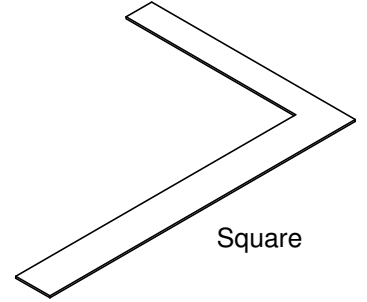

Square

Remove Paper Strips and Place Track as Shown Below.

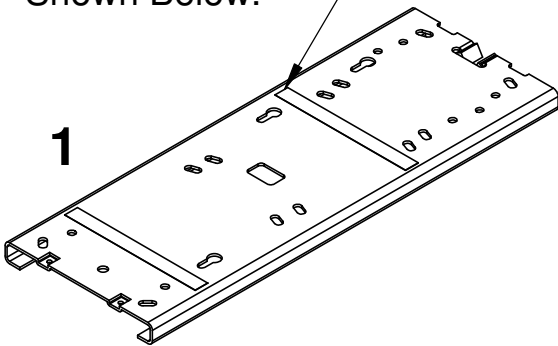

1

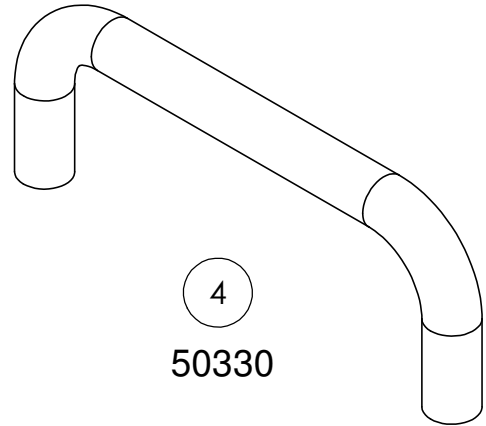

50330

Square With The Front of The Worksurface And Back 3/8".

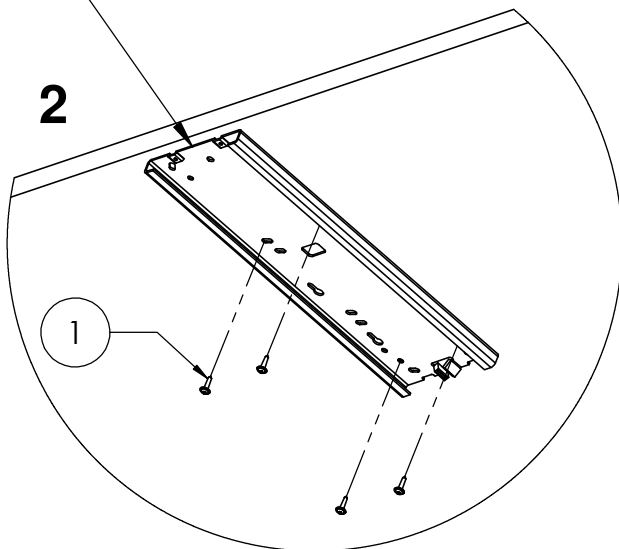

2

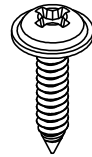

1

51708 x4



2

52679 x2

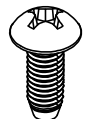

3

50200 x2

CPU narrower than 3-7/8" ? See page 4.

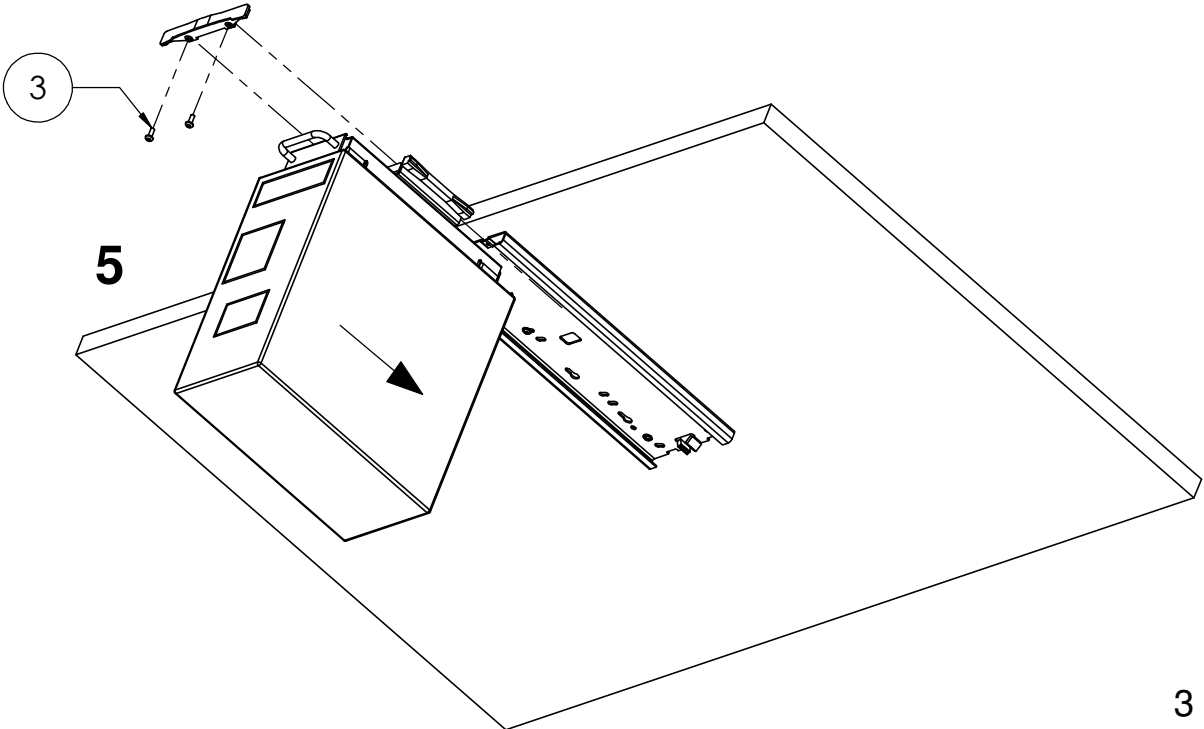
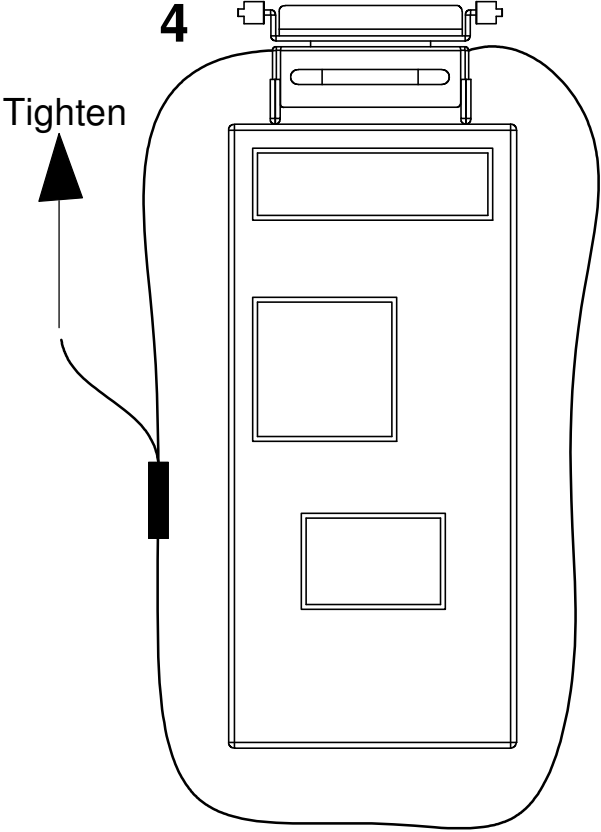
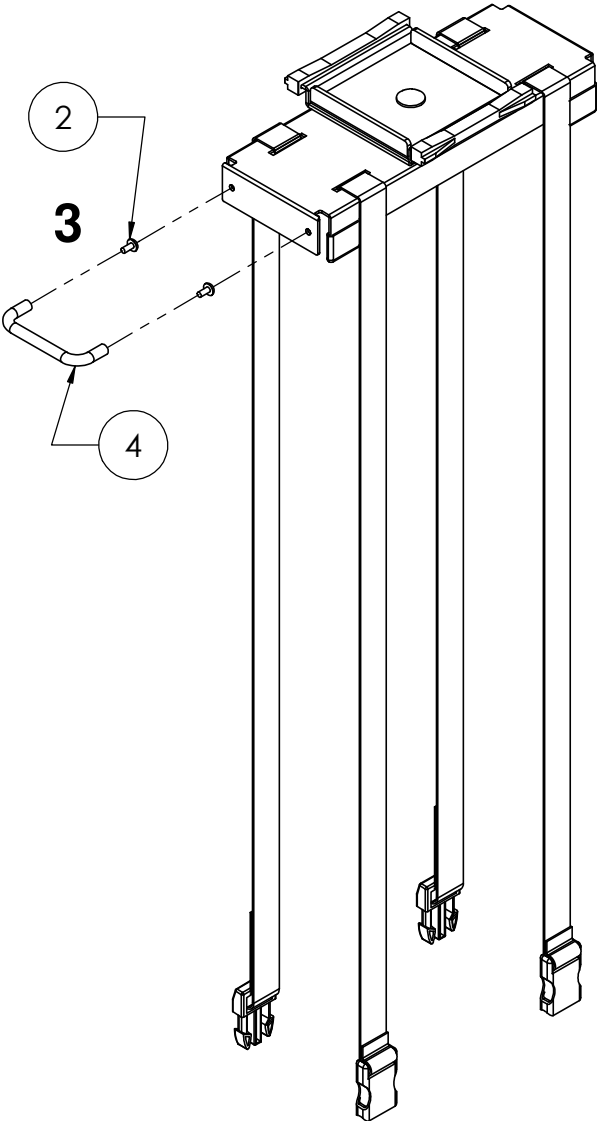

**If your CPU is less than 3-7/8" wide,
follow the steps below.**

Remove the buckles from the straps.
Pull the straps off the CPU holder.

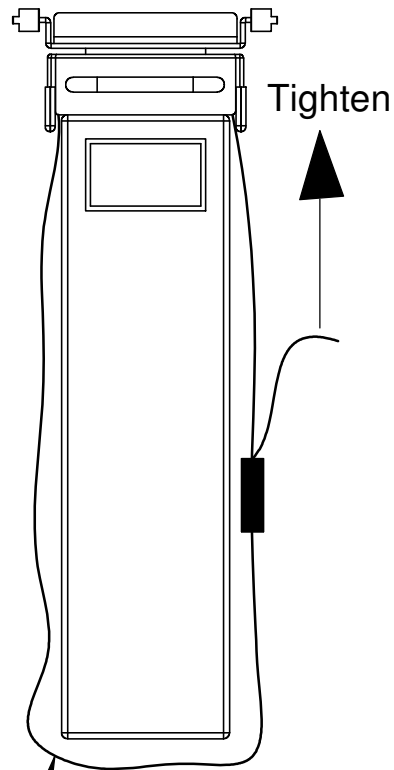

Route the ends up through
the right hand slots, then
down through the left hand
slots. Reattach the buckles.