











# ASSEMBLY INSTRUCTIONS

Description : END TABLE

NO	Parts List		Q'TY
1	TABLE		1PC
2	TABLE LEG		2PCS
3	SHELF		1PC

NO	Hardware List		Q'TY
A	BOLT		Ø5/16" * 40 mm 4 PCS
B	LOCK WASHER		Ø5/16" * 11* 1mm 6 PCS
C	WASHER		Ø5/16" * 22 *2 mm 4 PCS
D	ALLEN KEY		58 * 4mm 1PC
E	THREAD BOLT		Ø5/16" * 75mm 2PCS
G	HEX NUT		Ø5/16" * 12D* 6 mm 2PCS
H	U-SQUARE FLAT WASHER		Ø5/16", D174 2PCS
I	OPEN WRENCH		Ø5/16" * 22 *2 mm 1PC

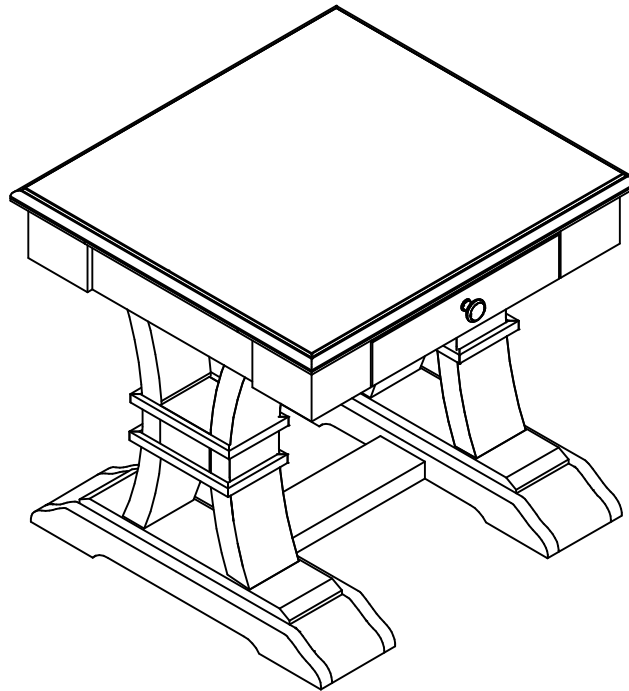

# STEP 1

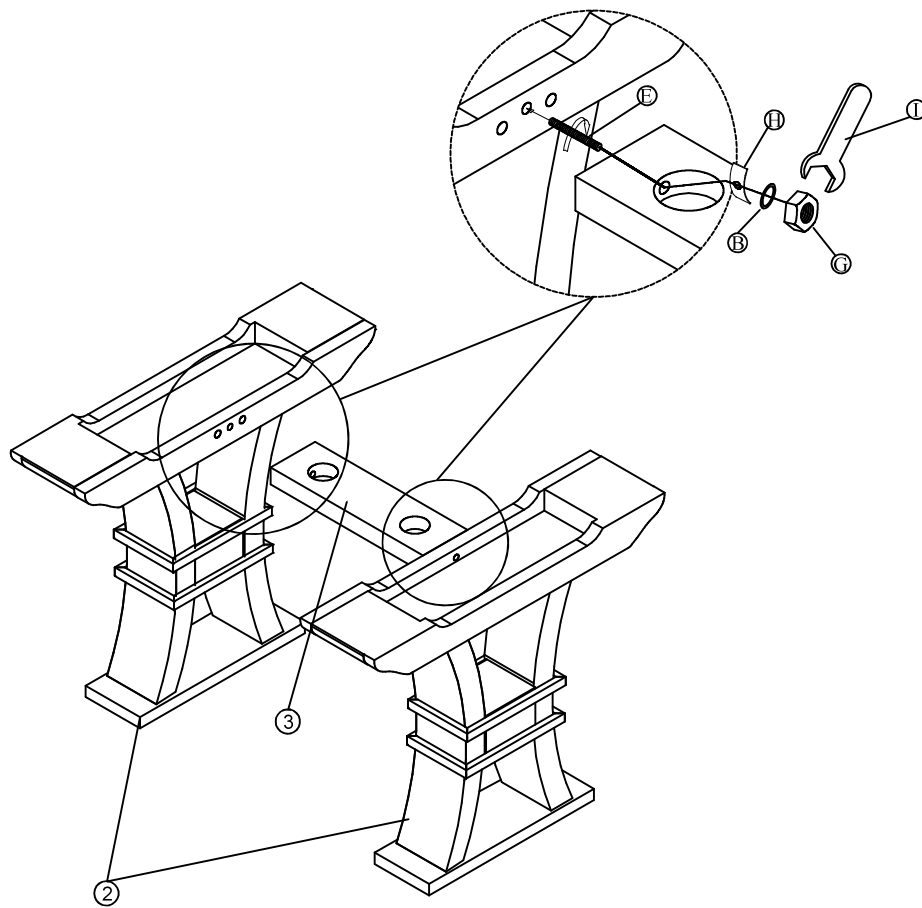

# STEP 2

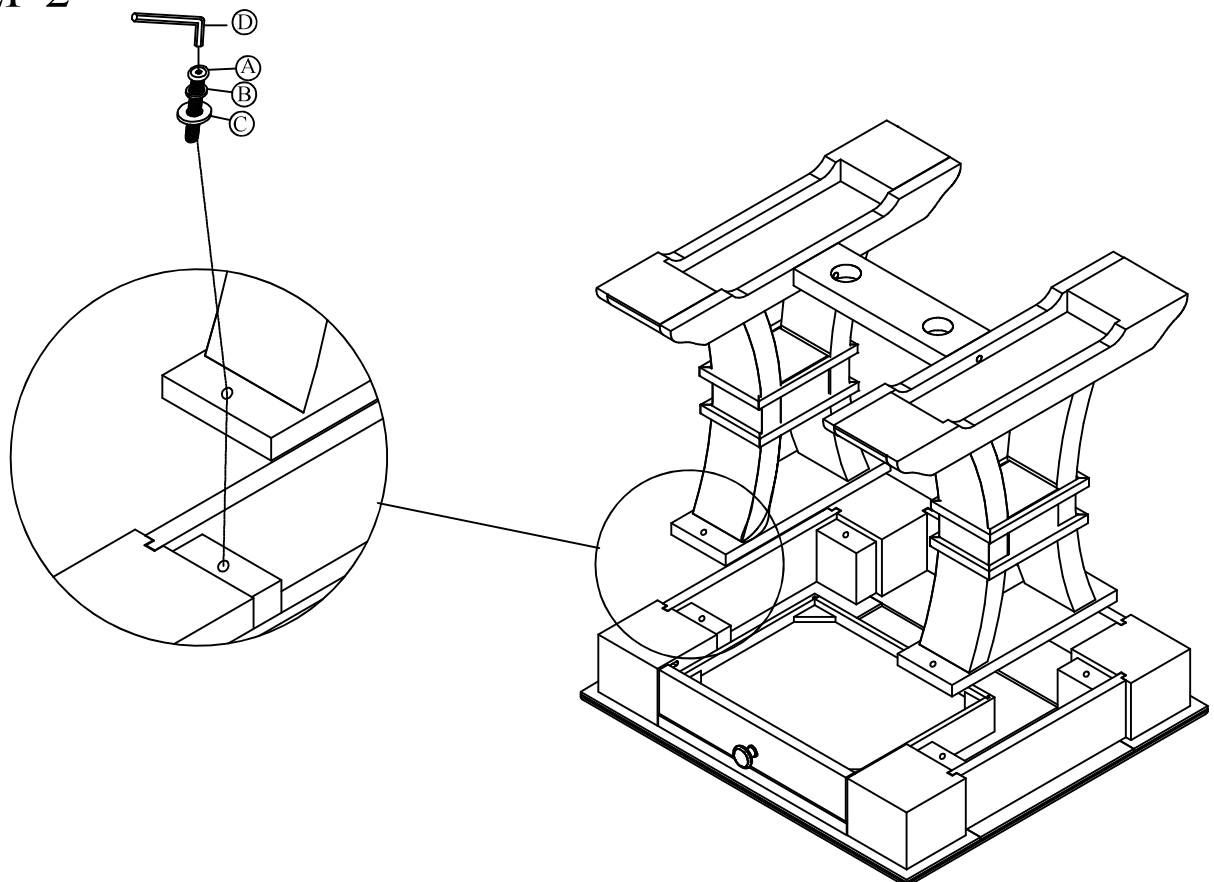

## STEP 3

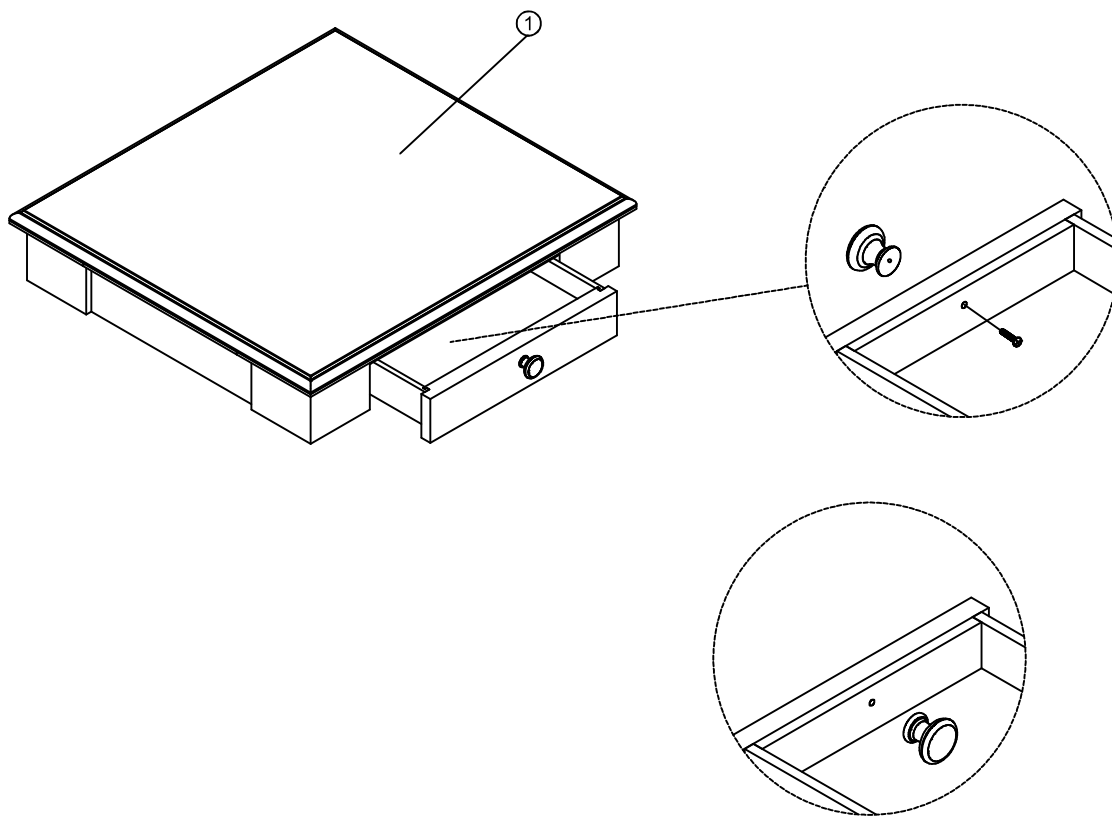

## STEP 4

