

ASSEMBLY INSTRUCTIONS

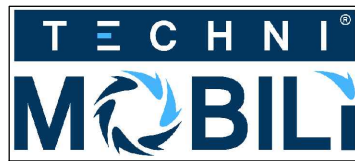

MODEL RTA-8807

Thanks for purchasing one of our products.
Please read carefully the assembly instructions before the installation.
Please save this manual for future reference.

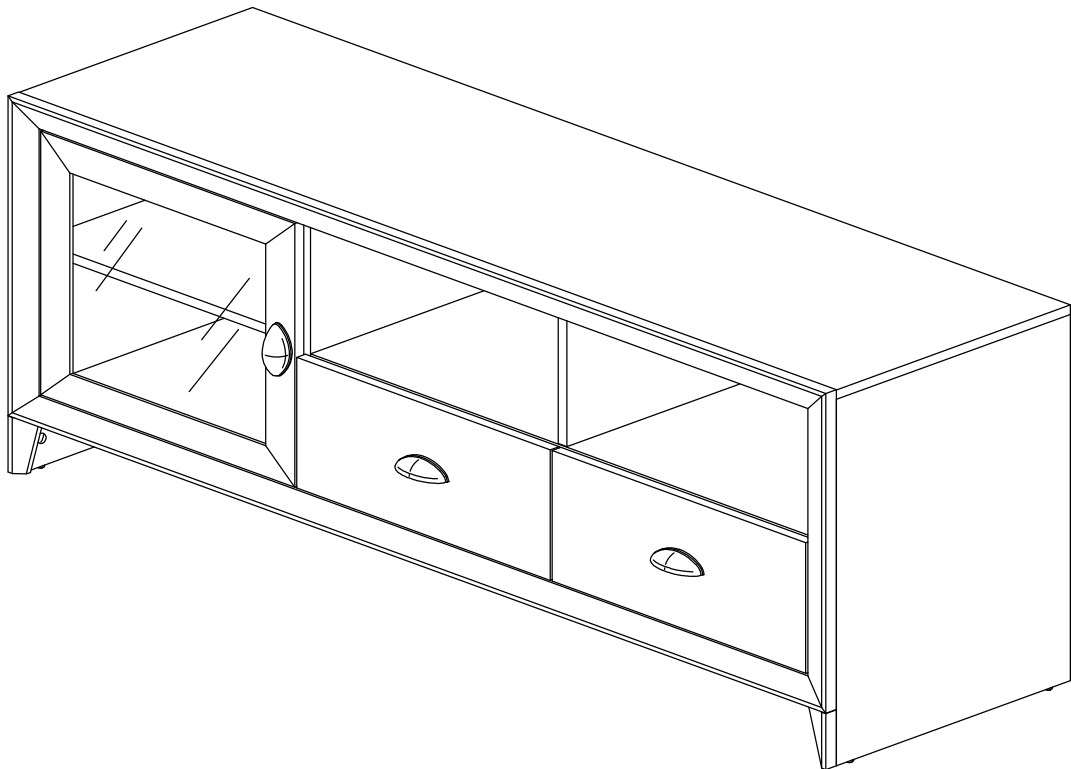

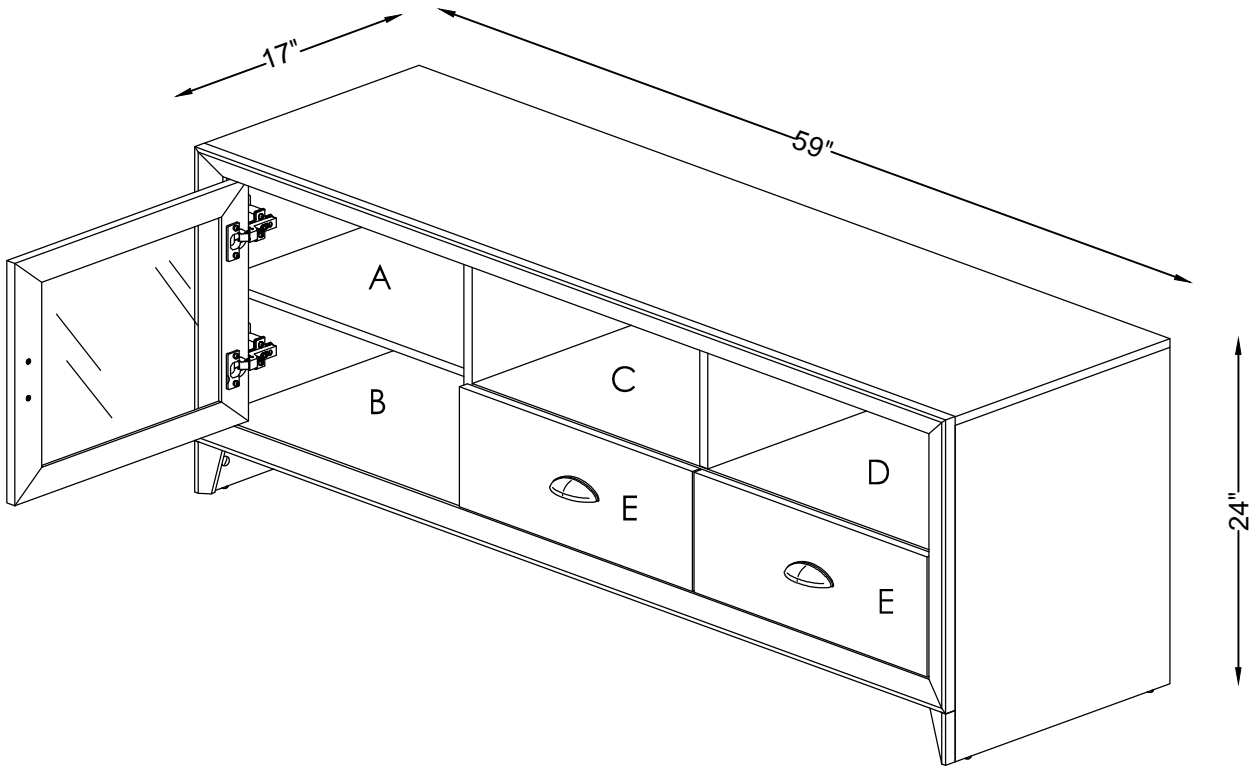

GENERAL SPECIFICATIONS

WIDTH : 59"

DEPTH : 17"







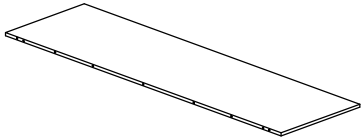
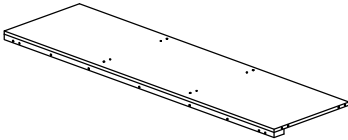
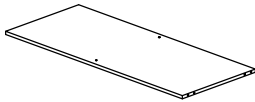
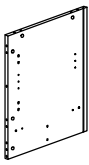

HEIGHT : 24"

PRODUCT NET WEIGHT : 89.3 Lbs

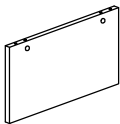
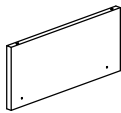
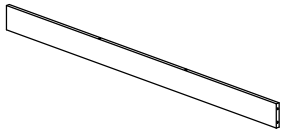

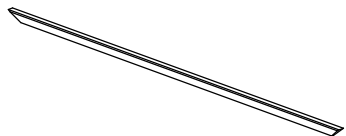

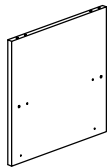
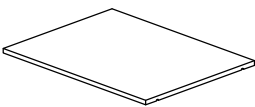
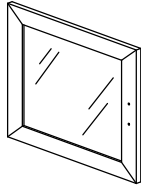
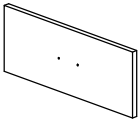
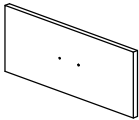
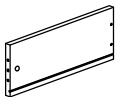
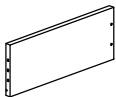
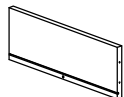

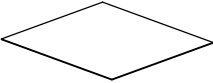
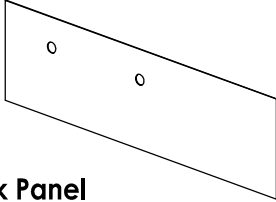

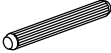

SHIPS IN 1 BOX







	INTERNAL DIMENSIONS (WxDxH)	WEIGHT LIMIT
TOP	N/A	110 LBS
STORAGE A	18" x 15" x 8.81"	35 LBS
STORAGE B	18" x 15" x 9.92"	55 LBS
STORAGE C	17.24" x 14.56" x 9.52"	35 LBS
STORAGE D	17.99" x 14.56" x 9.52"	35 LBS
DRAWER E	14.44" x 13.18" x 5.7"	30 LBS

•PARTS LIST

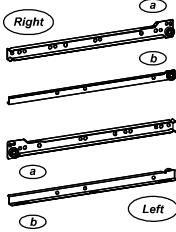
<p>A</p>  <p>▪ Top Main Panel</p>	<p>B</p>  <p>▪ Bottom Panel</p>	<p>C</p>  <p>▪ Middle Shelf</p>		
<p>D</p>  <p>▪ Side Panel (Left)</p>	<p>E</p>  <p>▪ Side Panel (Right)</p>	<p>F</p>  <p>▪ Partition panel (Upper)</p>	<p>G</p>  <p>▪ Partition panel (Lower)</p>	
<p>H</p>  <p>▪ Bottom Crossbar</p>	<p>I</p>  <p>▪ Frame Leg (Left)</p>	<p>J</p>  <p>▪ Frame Leg (Right)</p>	<p>K1</p>  <p>▪ Horizontal Frame x 2</p>	
<p>K2</p>  <p>▪ Vertical Frame x 2</p>	<p>L</p>  <p>▪ Partition (Big)</p>	<p>M</p>  <p>▪ Shelf Panel</p>	<p>N</p>  <p>▪ Door</p>	
<p>O</p>  <p>▪ Drawer Front (Left)</p>	<p>P</p>  <p>▪ Drawer Front (Right)</p>	<p>Q</p>  <p>▪ Drawer Side (Left) x 2</p>	<p>R</p>  <p>▪ Drawer Side (Right) x 2</p>	<p>S</p>  <p>▪ Drawer Back x 2</p>
<p>T</p>  <p>▪ Drawer Crossbar x 2</p>	<p>U</p>  <p>▪ Drawer Bottom x 2</p>	<p>V</p>  <p>▪ Back Panel</p>		

•HARDWARE

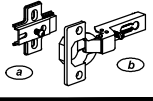
PART	QTY.	ITEM	
1	52Pcs	Wooden Pin	
2	2Pcs	Wooden Pin	
3	8Pcs	Screw - 5 x 8mm (Euro Screw)	
4	20Pcs	Screw - 3.5 x 15mm	
5	10Pcs	Screw - 4 x 38mm	
6	4Pcs	Screw - 5 x 38mm	
7	8Pcs	TP 10#x1/2" Screw	
8	20Pcs	Nail	
9	38Sets	Cam Lock & Bolt Sets	
10	10Pcs	Plastic Cap	
11	4Pcs	Metal Pin	

PART	QTY.	ITEM	
12	2Sets	Metal Guides Sets	
13	4Pcs	Plastic Base	
14	3Sets	Handle Set	
15	5Pcs	Plastic Feet	
16	2Sets	Door Hinge Set	
17	2Pcs	L Bracket	

 • Cam Bolt

 • Cam Lock

▪ BOLT INSTALLATION AS BELOW :

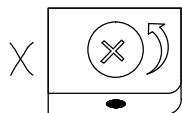
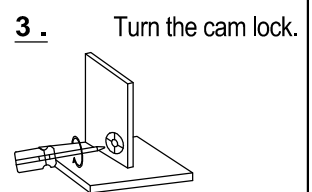
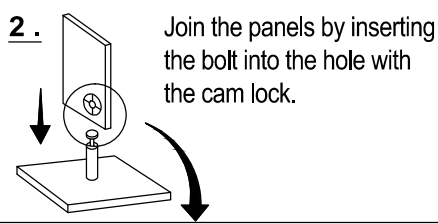
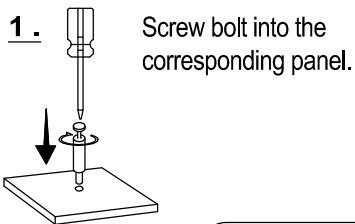

INCORRECT:
Turn cam lock

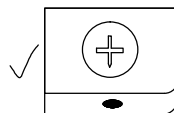

CORRECT:

▪ Before assembling panels that use the cam bolt and cam lock. Make sure that the cam lock is aligned to receive the bolt.

GENERAL ASSEMBLY TIPS AND TROUBLESHOOTING DURING ASSEMBLY:

- * Before you start assembling, make sure you have all the parts and necessary hardware by doing a quick inventory.
- * Follow the assembly instructions step by step, and do not skip any unless advised to do so by RTA PRODUCTS' Customer Service.
- * On each step, and to avoid misalignments, always leave screws loose, and do not tighten them until all are in place.
- * In wood panels, the laminate might be covering the holes.
If there are no visible holes: Pass the tip of your finger around the area where the hole should be, and press against the surface to feel the indentation.
If the hole looks too small for the screw or bolt: carefully perforate the laminate with the tip of a pen.

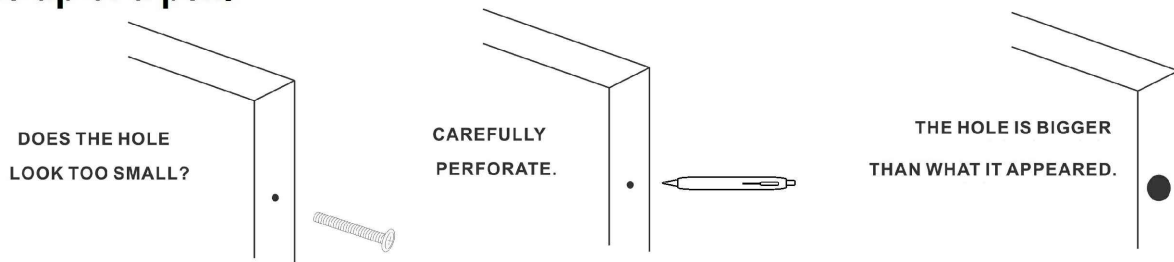

- * In wood panels, some might have inserts that look like screws. Those inserts are either nuts or cam locks. Make sure they are aligned to receive the screws or bolts.

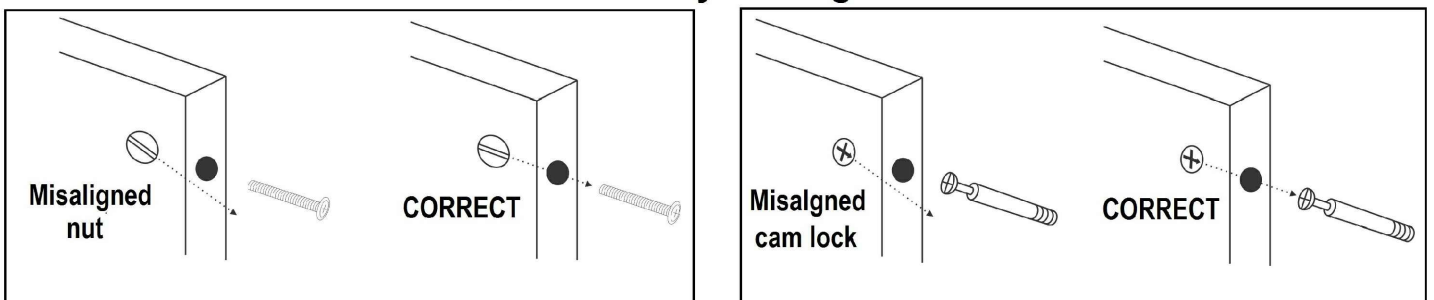

- * Make sure to use the correct screws or bolts, and do not overtighten them. Using wrong screws or overtightening them might cause damage to the parts, and such damage is not covered by the product's warranty.

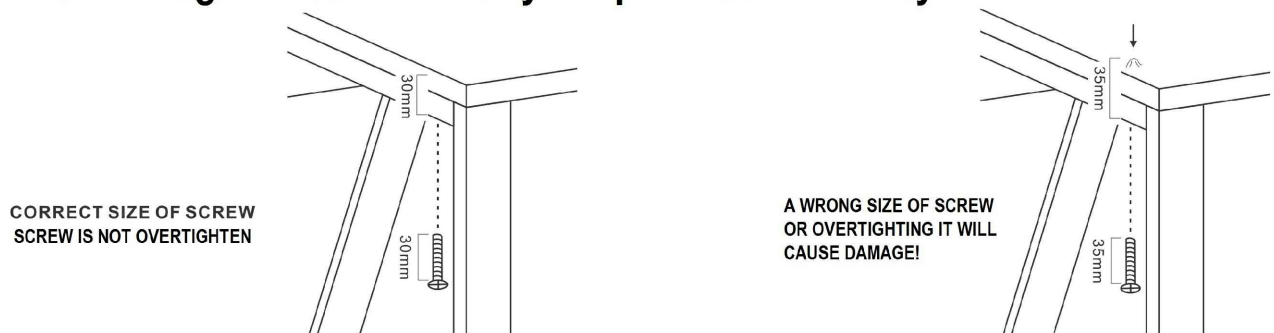

1

1  x52

MAKE SURE TO INSERT THE WOODEN PINS IN THE CORRECT HOLES AS SOME ARE INTENDED FOR OTHER KIND OF HARDWARE!

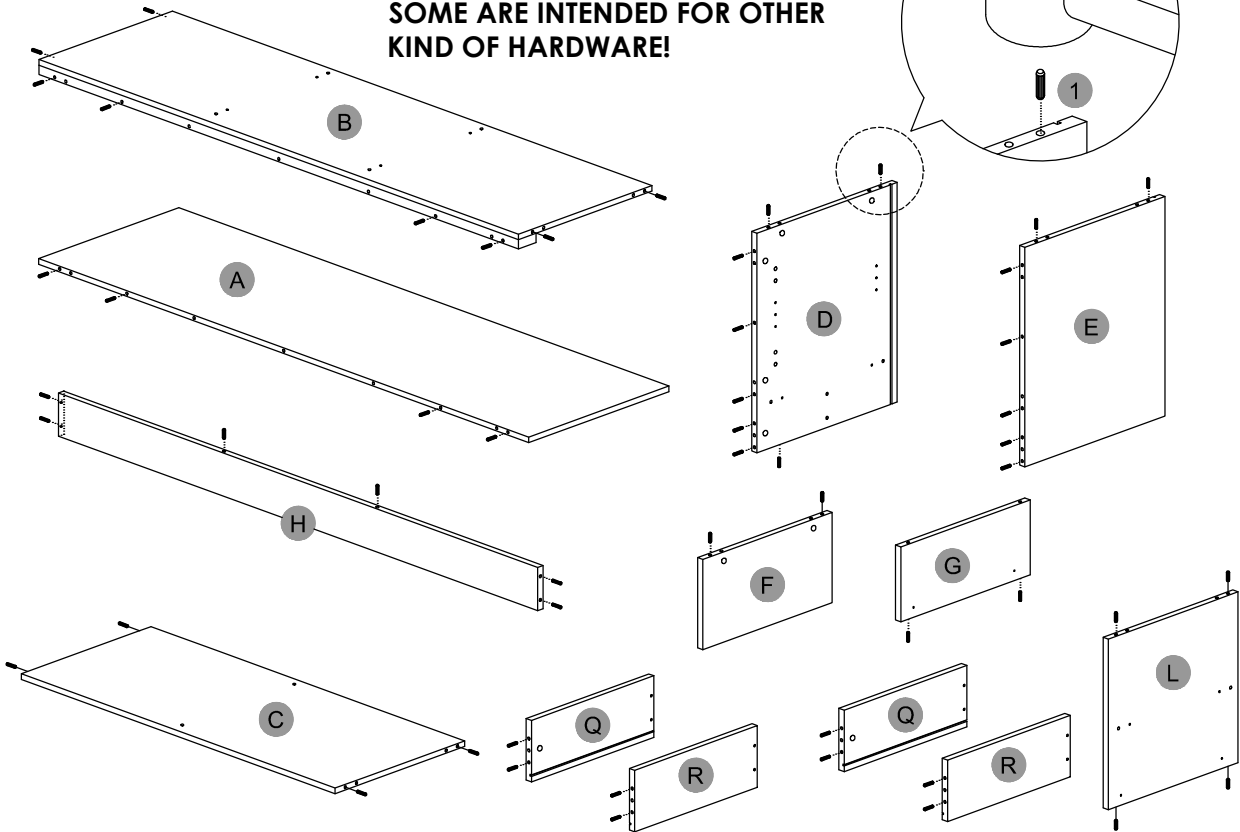

Install the wooden pins (1) into the panels (A), (B), (C), (D), (E), (F), (G), (H), (L), (Q) and (R) in the corresponding holes as shown in the illustrations, but make sure to use the correct holes as some are intended for other kind of hardware in subsequent steps.

2

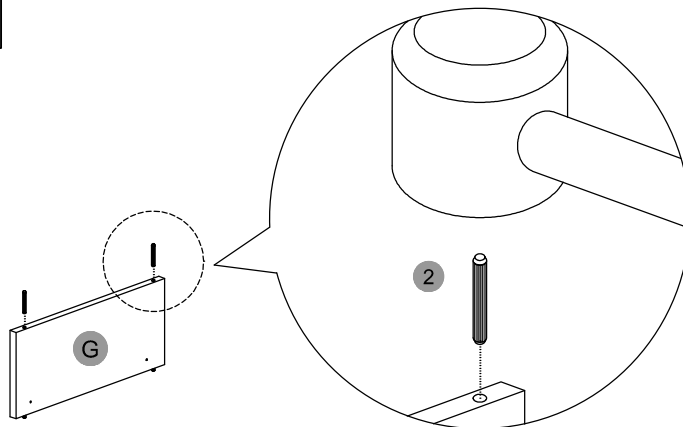
2  x2

Insert wooden pins (2) into the top of panel (G) as shown.

3

9 x8

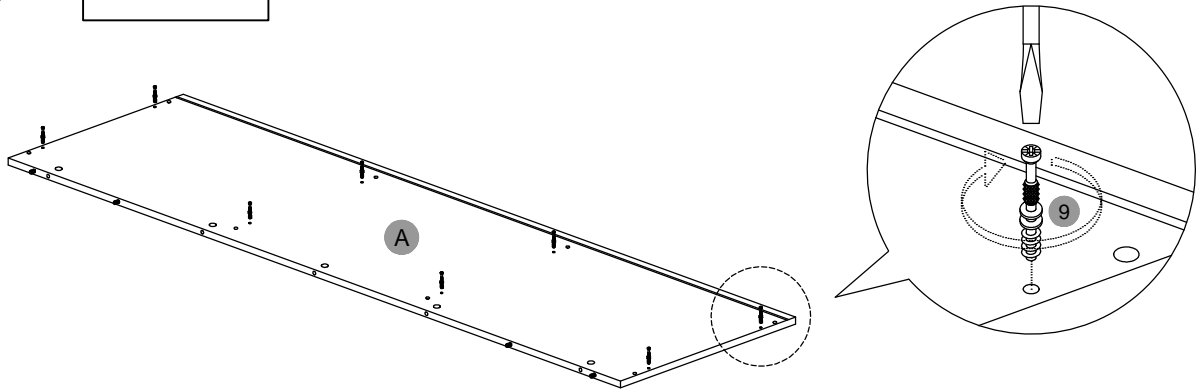

Attach cam bolts (9) to the corresponding holes on Main Panel (A) as shown, but make sure to use the correct holes as some are intended for other kind of hardware in subsequent steps.

4

9 x14

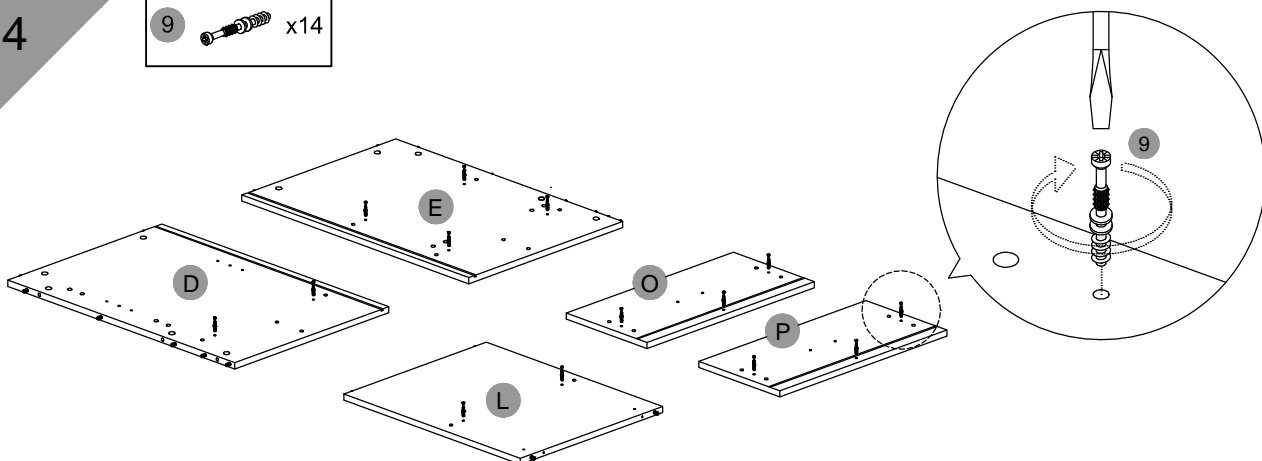

Attach cam bolts (9) to the corresponding holes on panels (D), (E), (L), (O) and (P) as shown, but make sure to use the correct holes as some are intended for other kind of hardware in subsequent steps.

5

11 x4

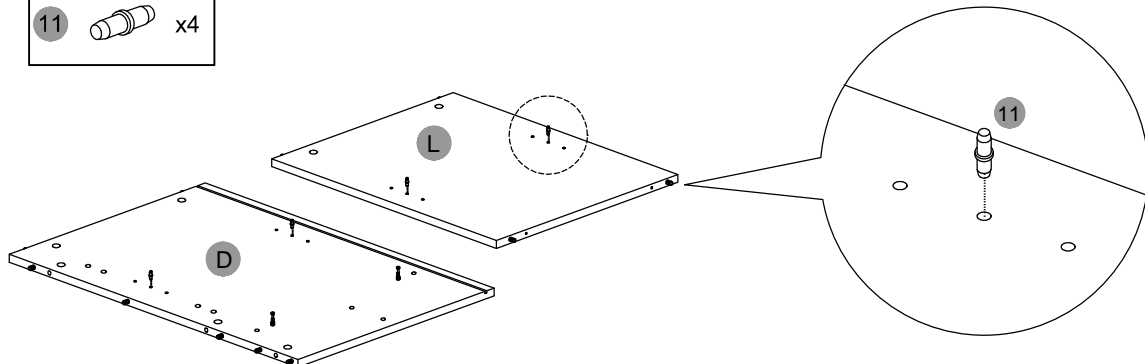

Insert the metal pins (11) into the corresponding holes on panels (D) and (L) as shown. You can adjust the height for the shelves later.

6

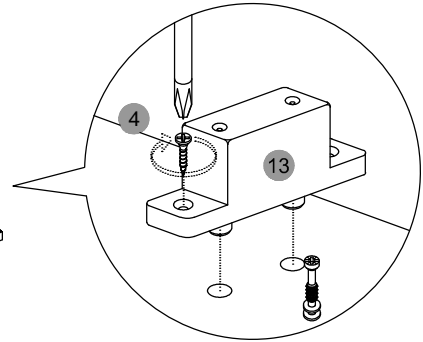
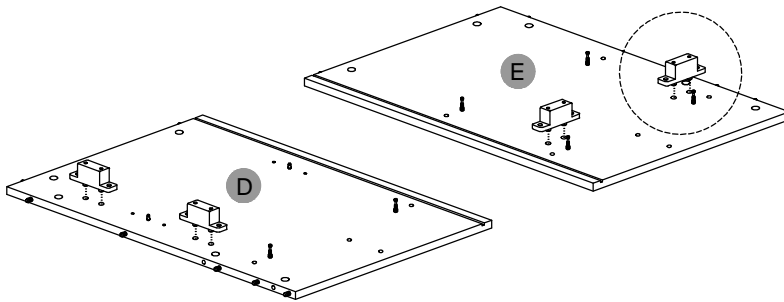
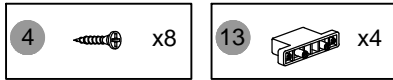

Assemble the plastic bases (13) to the panels (D) and (E) using screws (4) as shown.

7

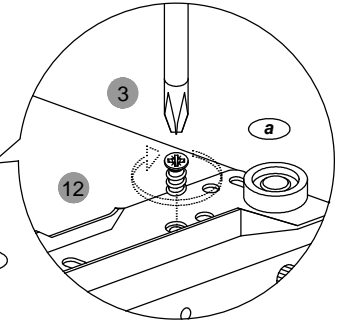
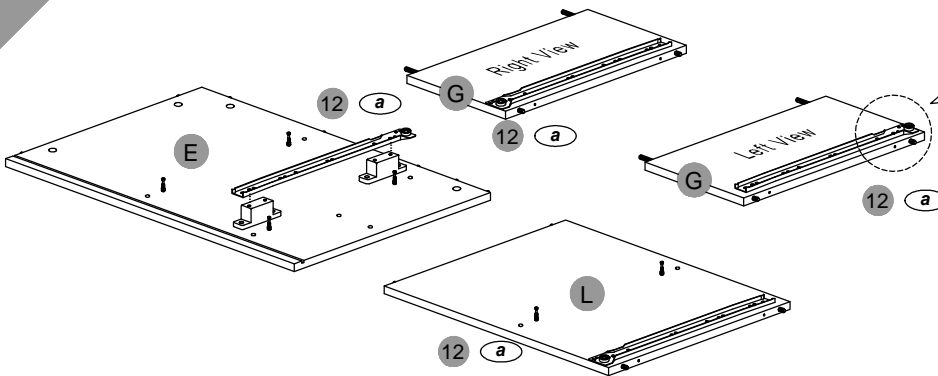
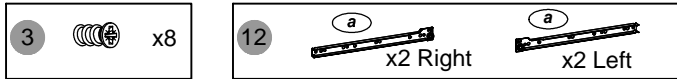

Assemble the FLAT sliders (12) to the panels (E), (G) and (L) using screws (3) as shown. Screw first at the front of the sliders then at the back. On panel (E), the slider assembles to the plastic bases (13), not the wood. NOTE: The "L" shape sliders are used until step 23.

8

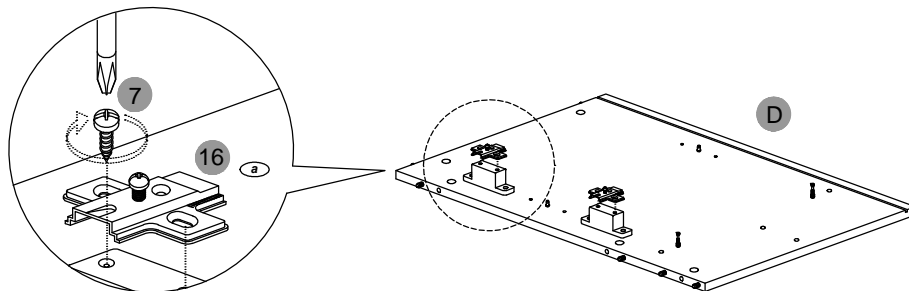
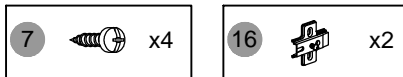

Grab the hinges (16) and if they come already joined, unscrew them in the middle to separate them into parts (a) and (b). Assemble part 16(a) to the hinge base (13) on panel (D) using screws (7) as shown.

9

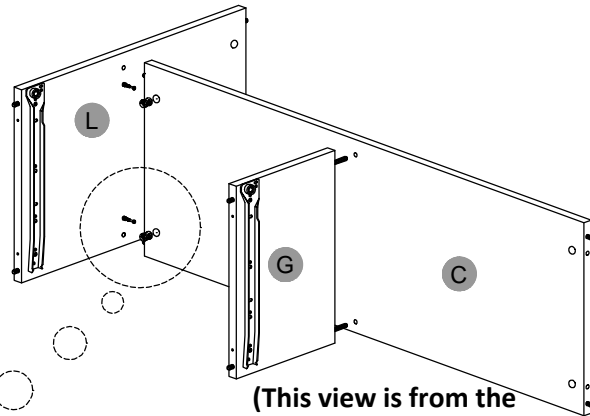
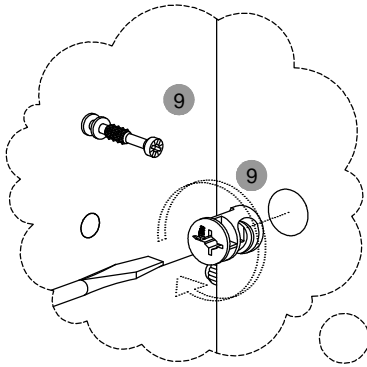
9  x2

(This view is from the underside of the unit)

First install and align the cam locks (9) to panel (C), then assemble the panel (L) to (C) as explained in page 4. Finally, join the panel (G) to panel (C) as shown.

10

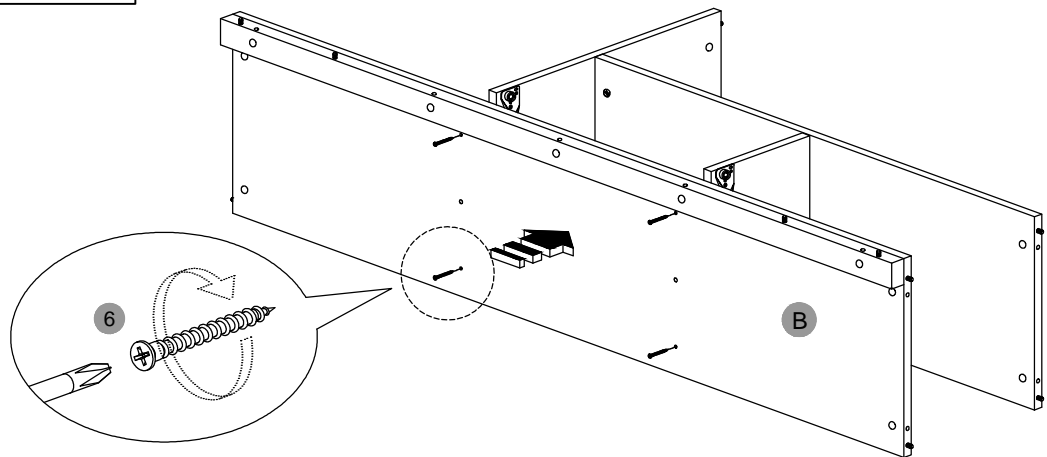
6  x4

Assemble the Bottom panel (B) to panels (G/L) using screws (6) as shown.

11

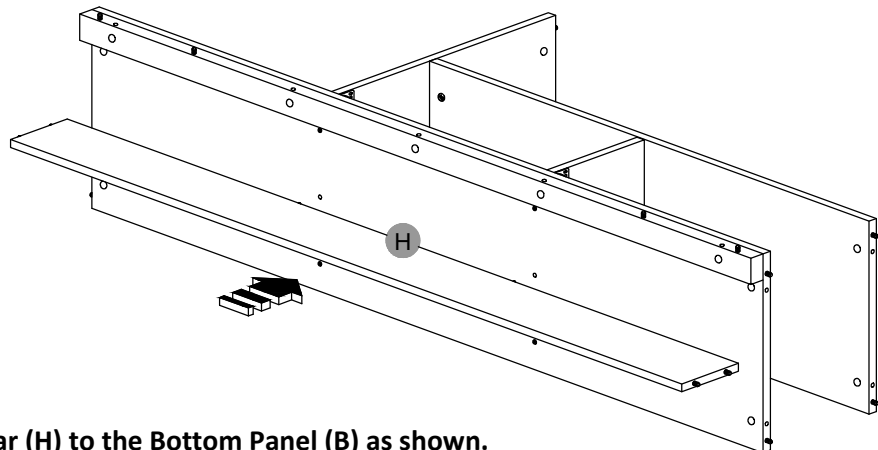

Join the Bottom Crossbar (H) to the Bottom Panel (B) as shown.

12

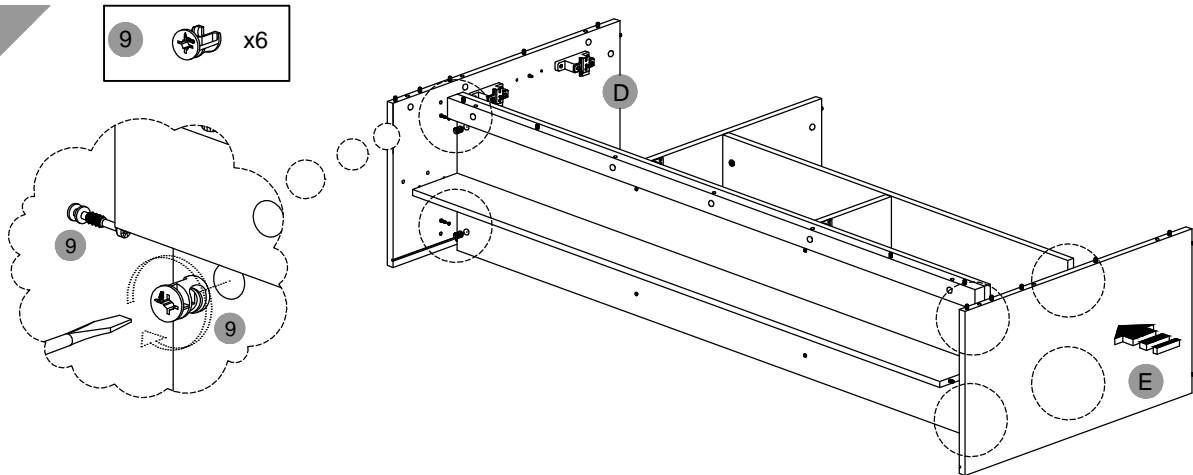

Install and align the cam locks (9) to the bottom panel (B) and middle shelf (C) in the locations shown, and assemble the panel (D) to (B) and panel (E) to (B/C) as explained in page 4.

13

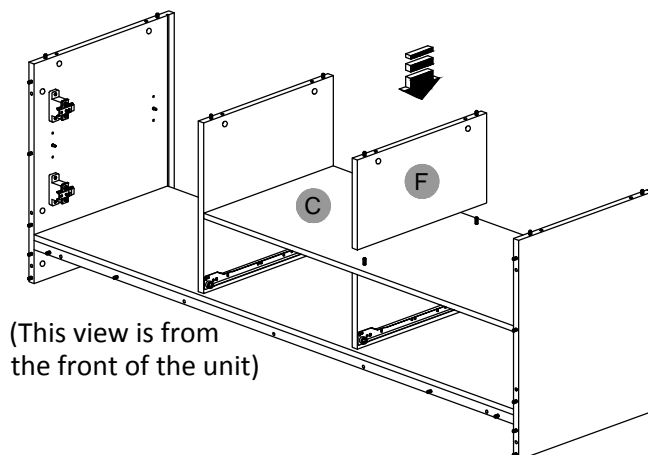

Attach the Partition Panel-Upper (F) to the Middle shelf (C) as shown.

14

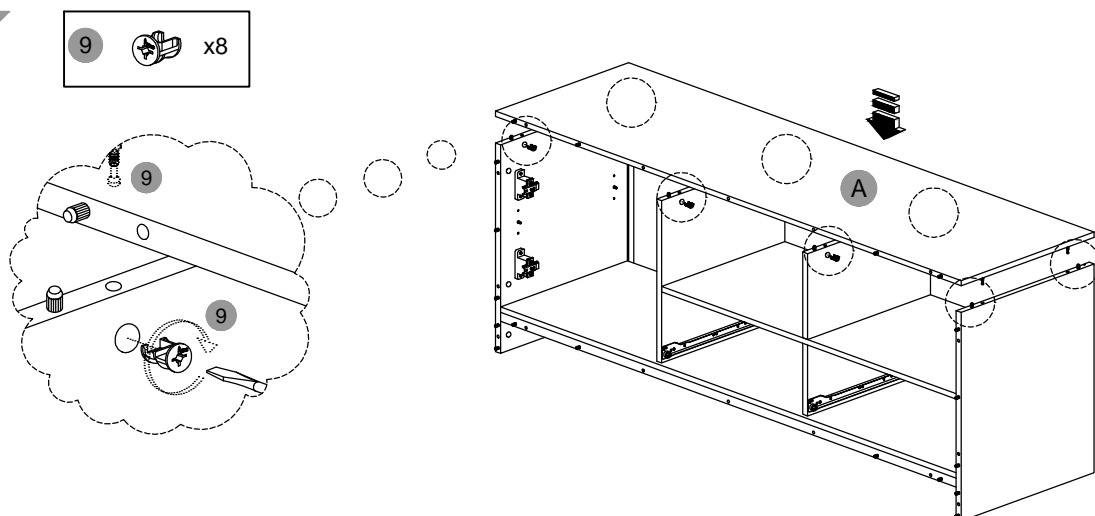

First install and align the cam locks (9) to the panels (D/L/F/E) in the locations shown, then assemble the Top panel (A) as explained in page 4.

15

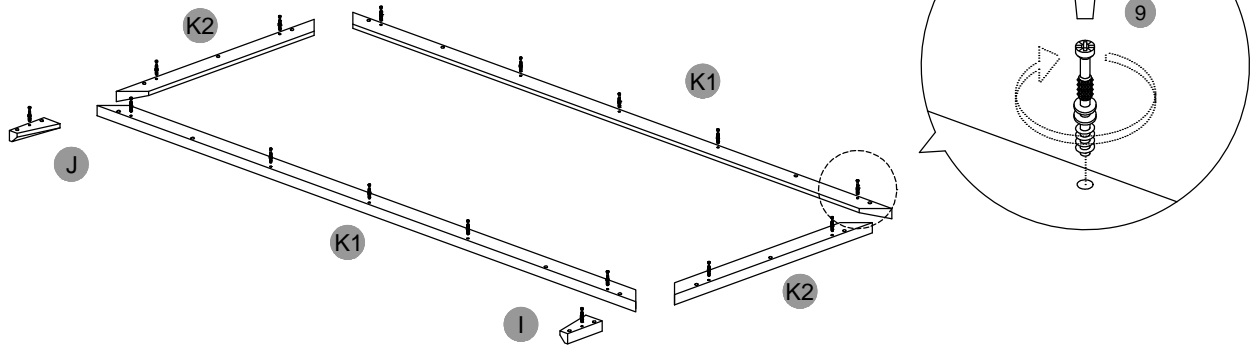
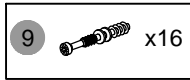

Attach the cam bolts (9) to the panels (I), (K1) and (K2) in the corresponding holes as shown, but make sure to use the correct holes as some are intended for other kind of hardware in subsequent steps.

16

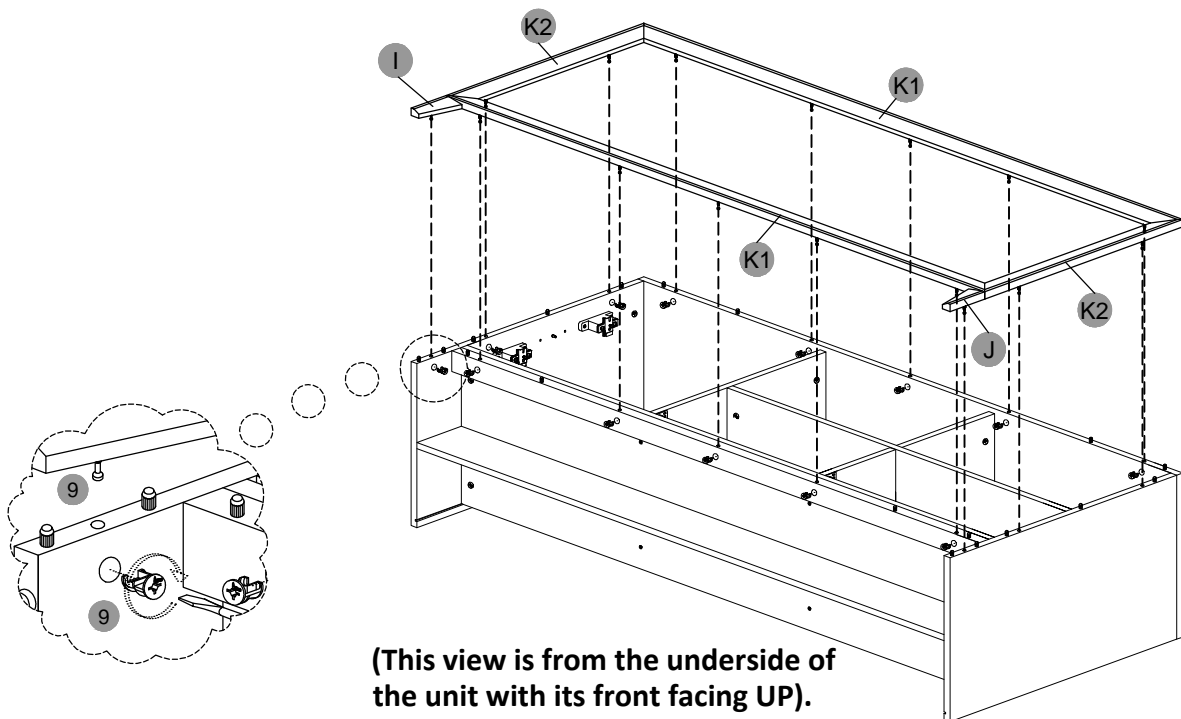

(This view is from the underside of the unit with its front facing UP).

First install and align the cam locks (9) to the panels (A/B/D/E) in the locations shown, then assemble the Top panel (A) as explained in page 4.

17

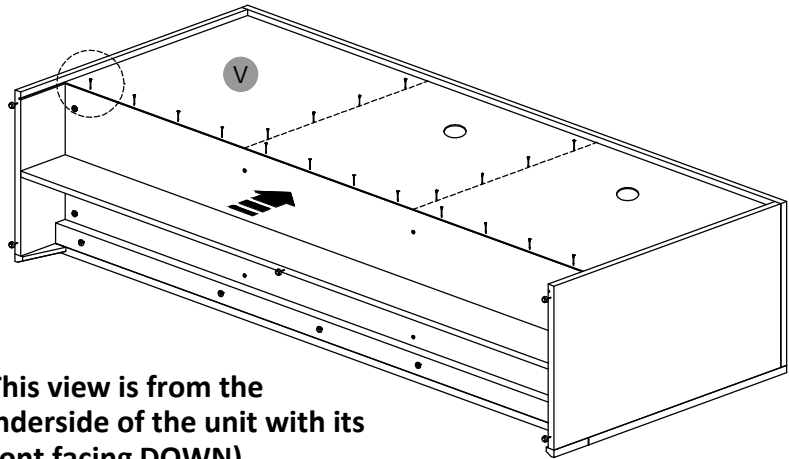
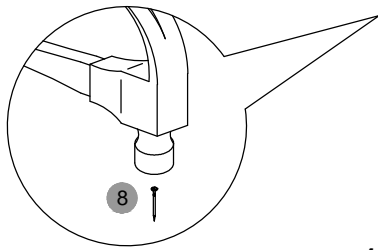
8  x20

(This view is from the underside of the unit with its front facing DOWN).

Attach the back panel (V) to the backside of the unit using nails (8) as shown, but please pay attention to the orientation of the cable holes on the panel.

18

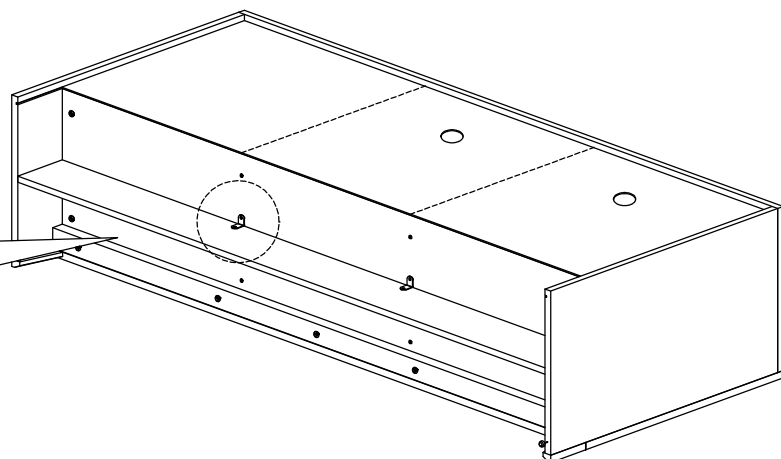
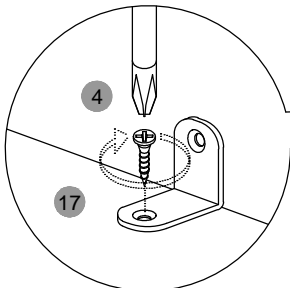
4  x417  x2

Attach the L bracket (17) to the panels (B) and (H) using screws (4) as shown.

19

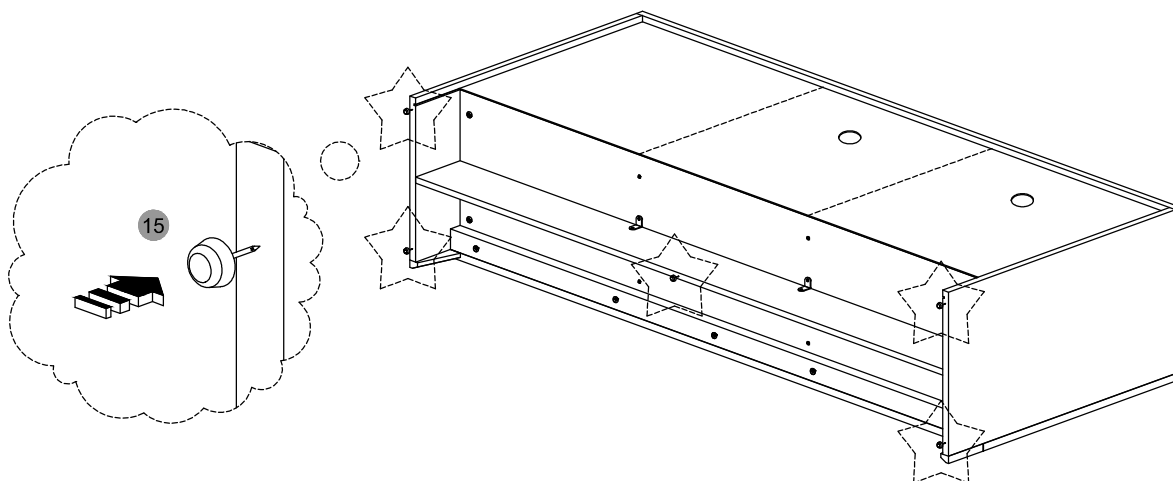
15  x5

Attach the plastic feet (15) to the panels (D), (E) and (H) as shown.

20

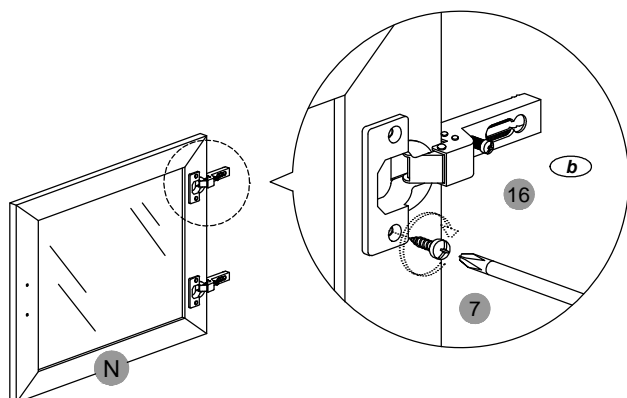
7  x416  x2

Attach the Door Hinges (16b) to the Door (N) using screws (7) as shown.

21

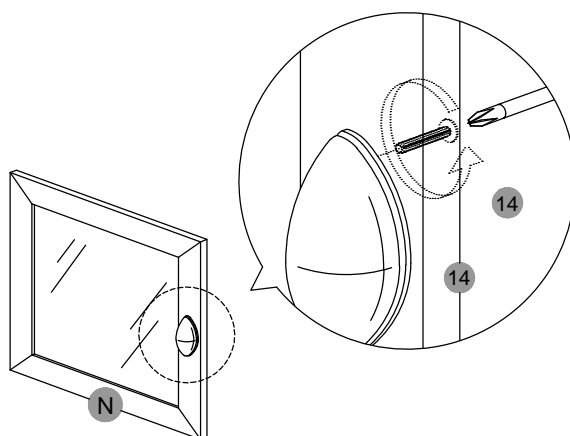
14  x1

Attach the Handle (14) to the Door (N) using the screws that come with it. Please note the orientation of the handle.

22

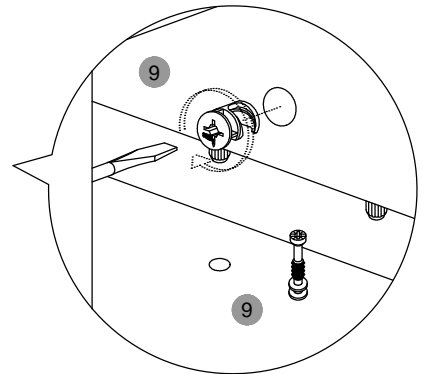
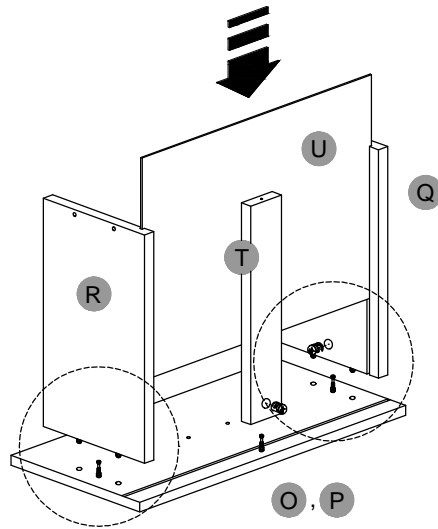
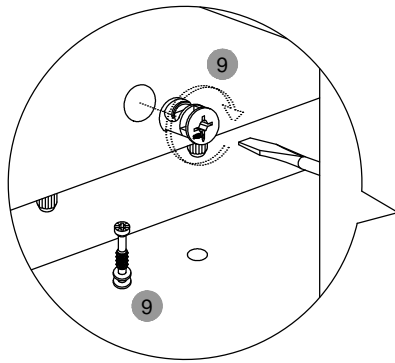

First install and align the cam locks (9) into the corresponding holes on panels (R), (T) and (Q) as explained in page 4. Then Assemble those panels to the Front panels (O) and (P) respectively as explained in page 4. Finally, slide the bottom panels (U) thru the grooves of panels (O/P/R/Q).

23

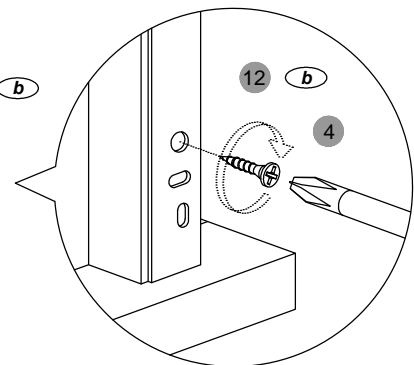
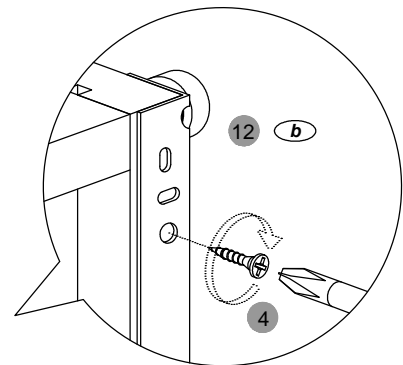
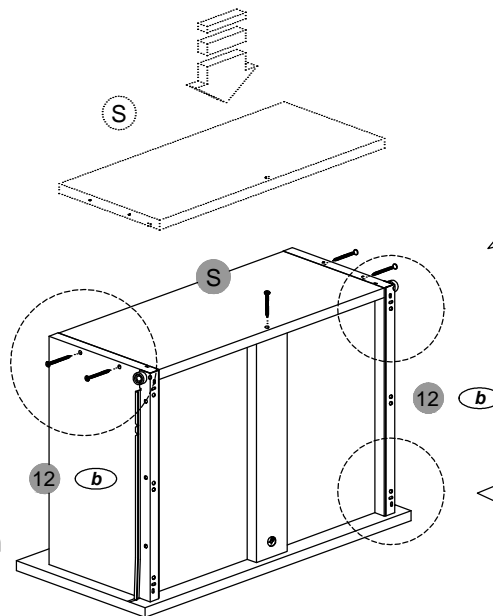
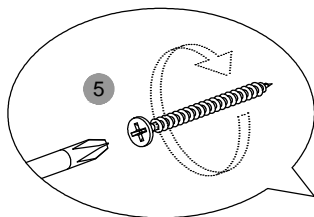
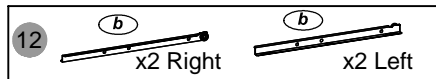
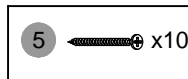
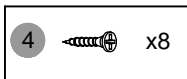

(This view is from the bottom of the drawer with is front facing down).

Assemble the back panel (S) to the panels (R/Q) using screws (5) as shown. Then grab the "L" shaped sliders (12) and assemble them to the bottom of the drawers using screws (4) as shown. NOTE: their wheels will be facing towards the back of the drawer. Also make sure the sliders are in contact with the wood on the bottom and the side.

24

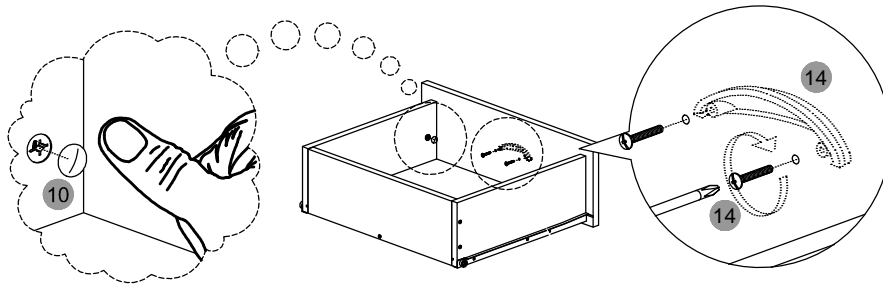
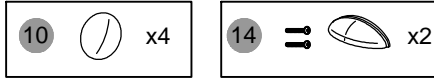

Assemble the handles (14) to the front panels (O) and (P) on both drawers using the screws that come with them. Please note the orientation of the handles. Then cover the cam locks with the plastic caps (10).

25

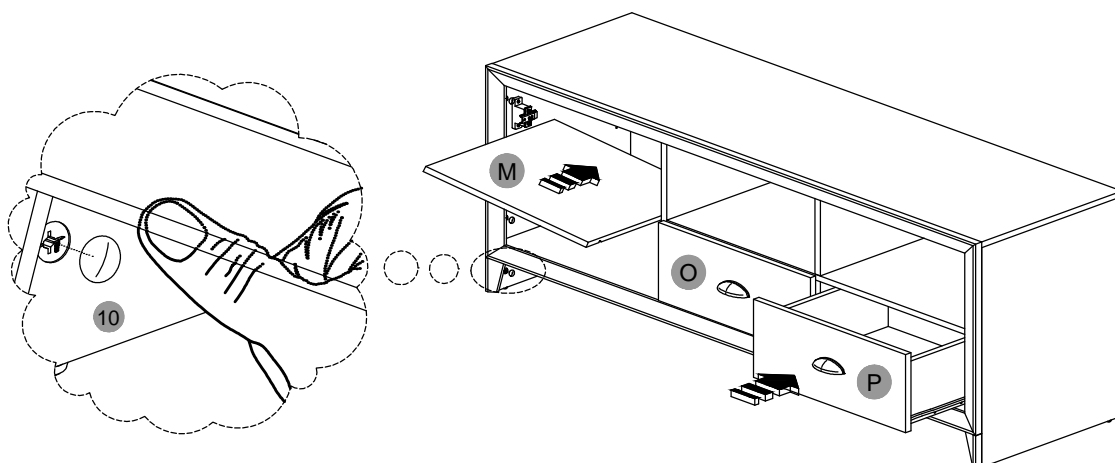
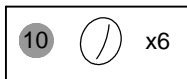

First insert the drawers into the unit, making sure the drawer with front panel (O) goes on the LEFT and the one with panel (P) goes on the RIGHT. Then insert the Shelf panel (M) into the unit. Finally, cover the cam locks that are visible at the front of the unit with the plastic caps (10).

26

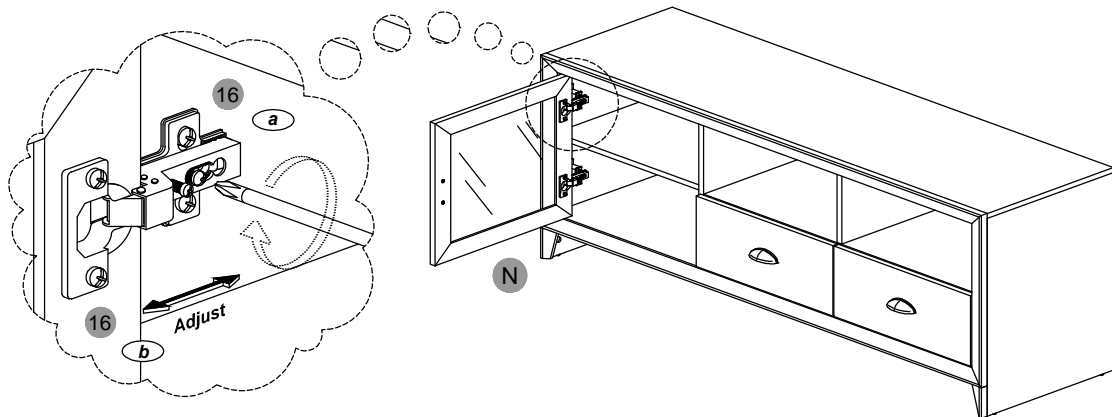

To fine-tune the position of the door, unscrew loose the hinges according to how the door should be adjusted:

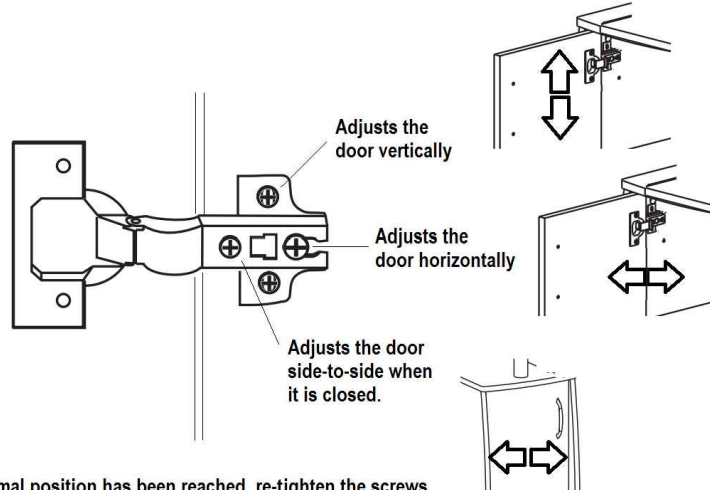

When the optimal position has been reached, re-tighten the screws.

Assemble the Door (N) to the unit by joining the 2 parts of the hinges as shown

CARE AND MAINTENANCE

PLEASE READ THOROUGHLY

- **Do not expose the surfaces to direct sunlight or to extreme environmental conditions. Damages caused by this kind of exposure is not covered by the product's warranty.**
- **Clean the surfaces preferable with a soft cloth damped with a solution of a mild soap and water, then dry with a clean towel.**
- **Do not use solvents or abrasive materials to clean any part of the unit.**
- **Do not allow children to play over or under the unit.**
- **Do not let children operate moving/mechanical parts or reach inside any of the compartments without your supervision.**
- **Before moving or transporting the unit:**
 - a) **Remove all objects from the tabletop, shelves, drawers or compartments that are heavy or might fall off.**
 - b) **If the unit is on wheels, make sure that they are unlocked.**
 - c) **If the unit is not on wheels, it must be handled by at least 2 persons. Use both of your hands and bend your legs, not your backs.**
- **In case of glass breakage (items with glass tops or parts) do not handle the broken glass with your bare hands, and notify the manufacturer, vendor or distributor immediately.**