

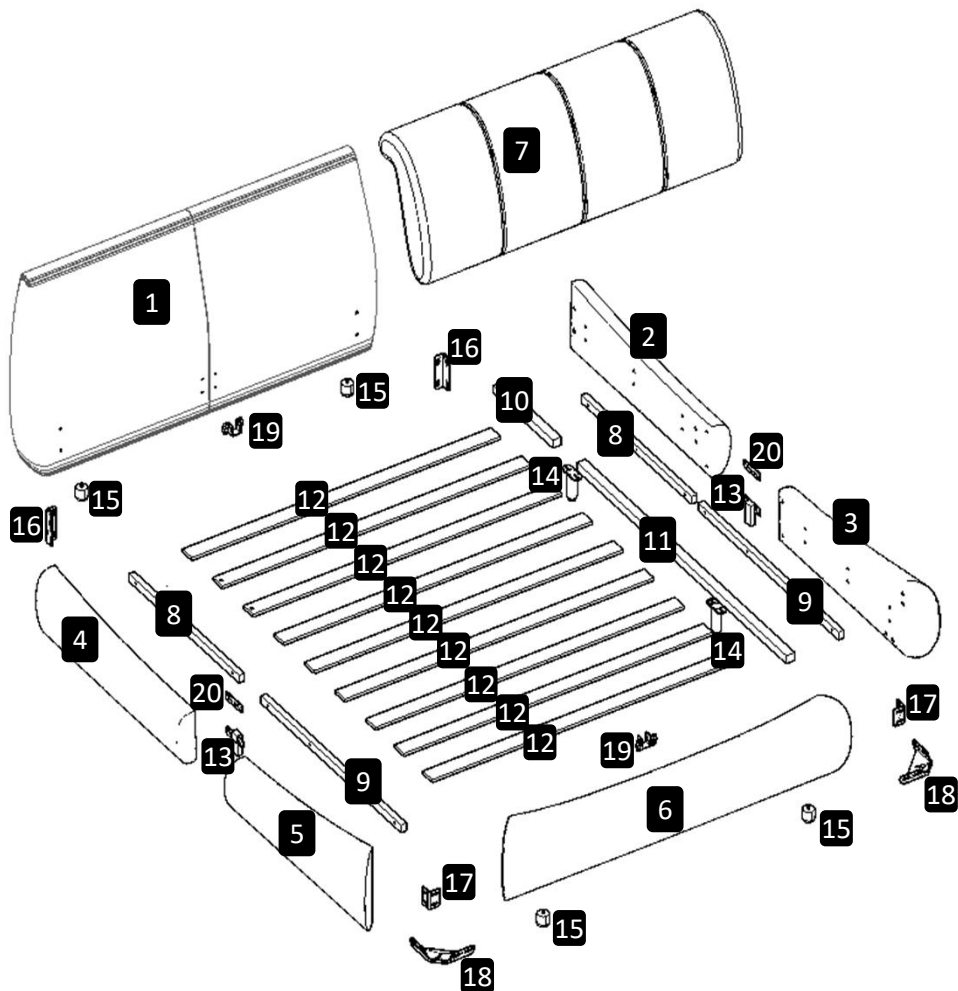

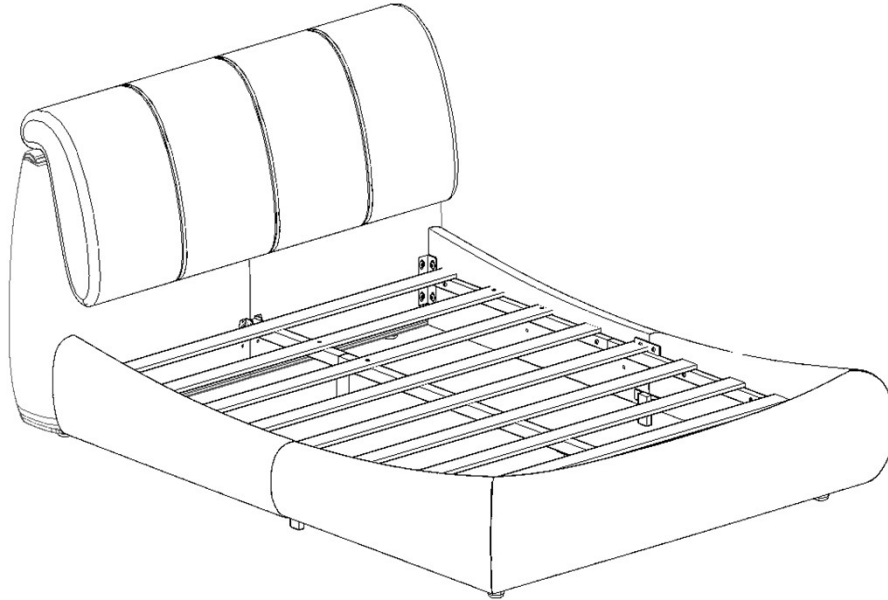



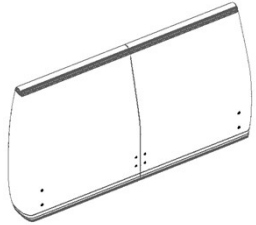
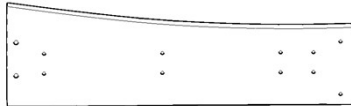
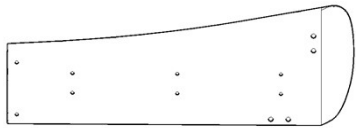
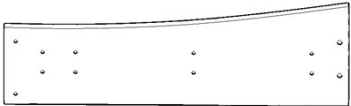
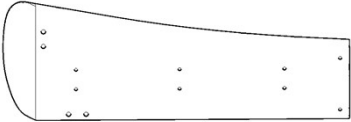
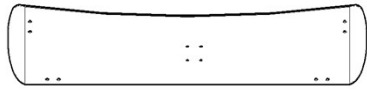
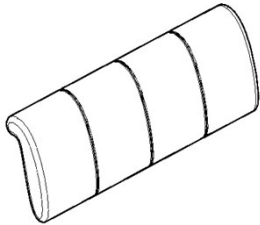
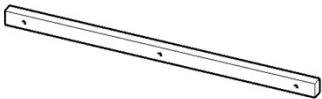

# ASSEMBLY INSTRUCTION

BW00045AAA / BW00045AAE/ BW00045AAK/BW00045AAL

- TIPS**
1. This bed fit standard twin mattress 80" L x 76" W.
  2. Always use the recommended size mattresses or mattress supports, or both, to help prevent the likelihood of entrapment or falls.
  3. Do not allow horseplay on or under the bed and prohibit jumping on the bed.
  4. Do not use substitute part. Contact the manufacture or dealer for replacement part.



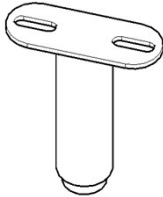

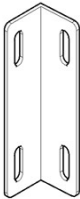
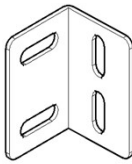
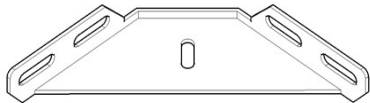



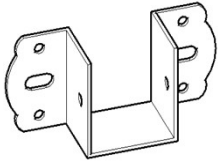
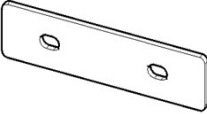



# Part List

<p>1</p>  <p>Headboard x1</p>	<p>2</p>  <p>Side Rail x1</p>	<p>3</p>  <p>Side Rail x1</p>
<p>4</p>  <p>Side Rail x1</p>	<p>5</p>  <p>Side Rail x1</p>	<p>6</p>  <p>Footboard x1</p>
<p>7</p>  <p>Soft Cushion x1</p>	<p>8</p>  <p>Side Support Bracket x2</p>	<p>9</p>  <p>Side Support Bracket x2</p>
<p>10</p>  <p>Support Frame x1</p>	<p>11</p>  <p>Support Frame x1</p>	<p>12</p>  <p>Slats x9</p>
<p>13</p>  <p>Short-Support Leg x2</p>	<p>14</p>  <p>Long-Support Leg x2</p>	<p>15</p>  <p>Plastic Feet x4</p>
<p>16</p>  <p>Long-Angle Lron x2</p>	<p>17</p>  <p>Short-Angle Lron x2</p>	<p>18</p>  <p>Triangle-Angle Lron x2</p>

## Part List

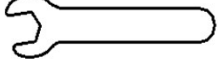
<p style="text-align: center;"><b>19</b></p>  <p style="text-align: center;">U-Shaped Bracket x2</p>	<p style="text-align: center;"><b>20</b></p>  <p style="text-align: center;">Iron Sheet x2</p>
---	---

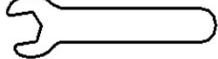
## Hardware List

<p style="text-align: center;"><b>A</b></p>  <p style="text-align: center;">Bolts(M6X20mm) X12</p>	<p style="text-align: center;"><b>B</b></p>  <p style="text-align: center;">Bolts(M6X40mm) X14</p>	<p style="text-align: center;"><b>C</b></p>  <p style="text-align: center;">Bolts(M8X20mm) X28</p>
<p style="text-align: center;"><b>D</b></p>  <p style="text-align: center;">Bolts(M8X50mm) X2</p>	<p style="text-align: center;"><b>E</b></p>  <p style="text-align: center;">Nut(M8) X4</p>	<p style="text-align: center;"><b>F</b></p>  <p style="text-align: center;">Flat Gasket X4</p>
<p style="text-align: center;"><b>G</b></p>  <p style="text-align: center;">Spanner(M6) X1</p>	<p style="text-align: center;"><b>H</b></p>  <p style="text-align: center;">Allen Key(M6) X1</p>	<p style="text-align: center;"><b>I</b></p>  <p style="text-align: center;">Spanner(M8) X1</p>
<p style="text-align: center;"><b>J</b></p>  <p style="text-align: center;">Allen Key(M8) X1</p>	<p style="text-align: center;"><b>K</b></p>  <p style="text-align: center;">Screws (M4X20mm) X6</p>	

## Step1

**Attention:** Do not tighten the screws before completing the entire installation. If you have any difficulty with the installation process, please feel free to contact us.

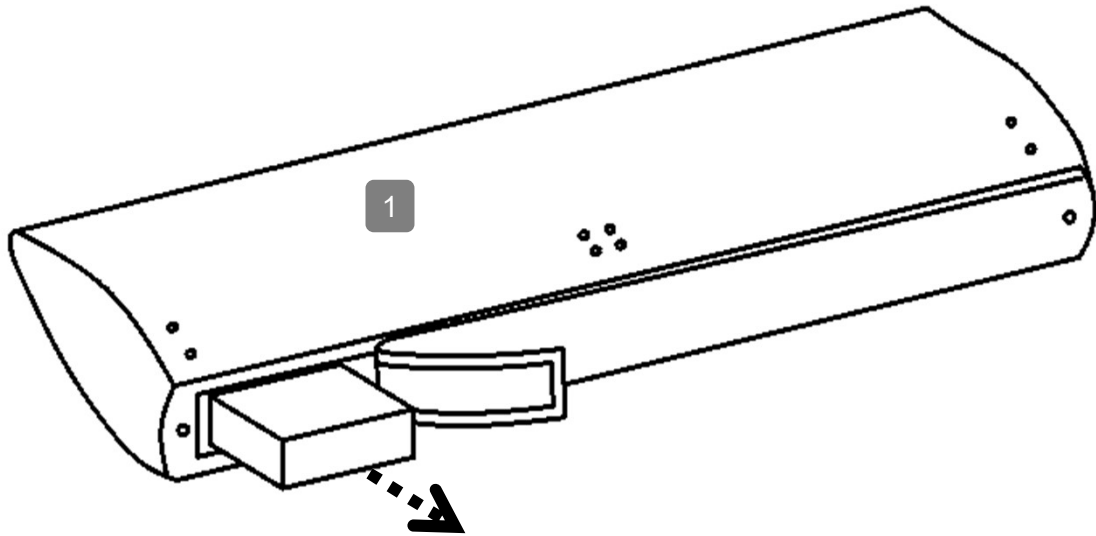

First, uncover the bottom cloth on the left side of the bed head, and then take out the hardware accessories carton

## Step2

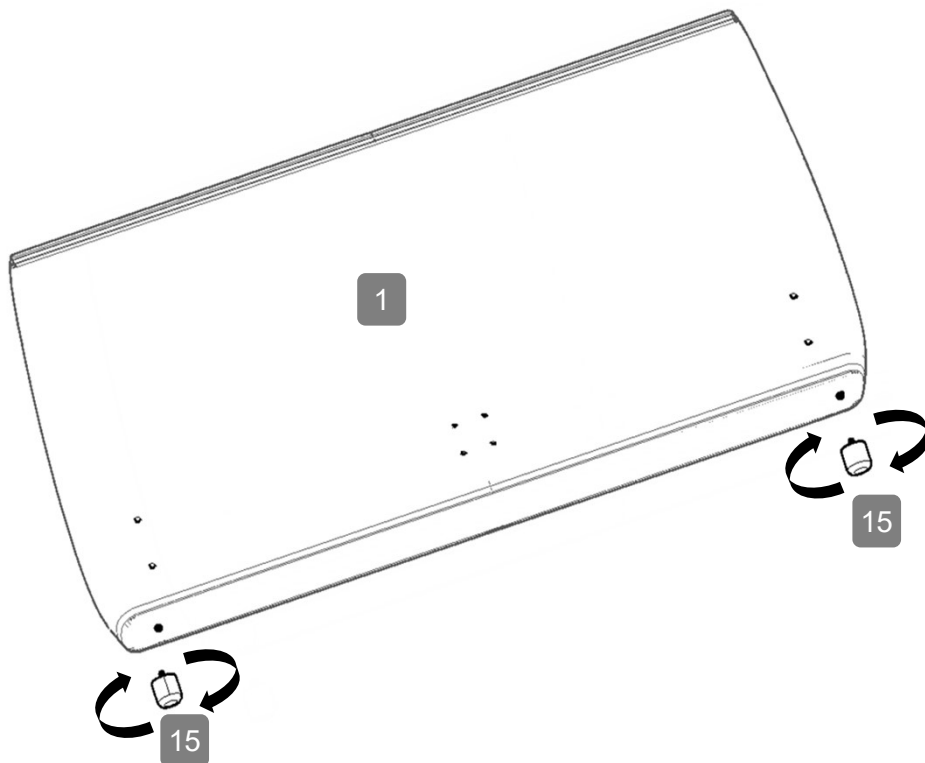

# Step3

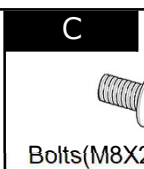
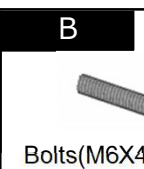
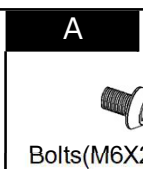
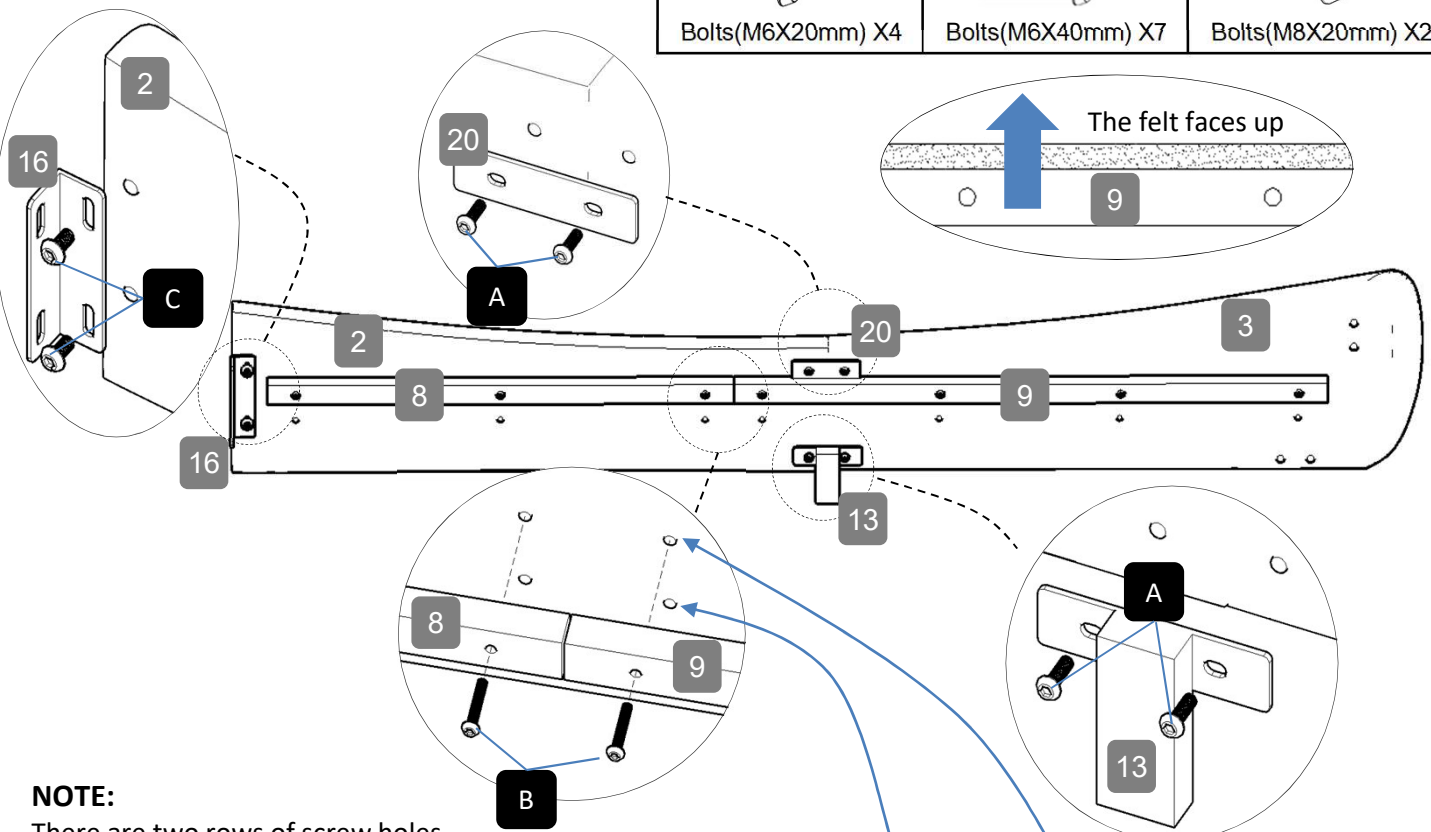



**NOTE:**

There are two rows of screw holes.  
If the mattress is more than 12 inches thick, install parts 8 and 9 into the lower screw holes.  
If the mattress is less than 12 inches thick, install parts 8 and 9 into the screw holes on the upper level

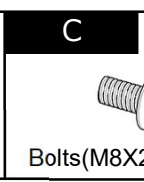
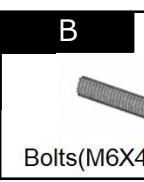
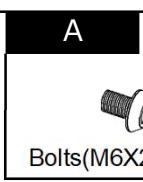
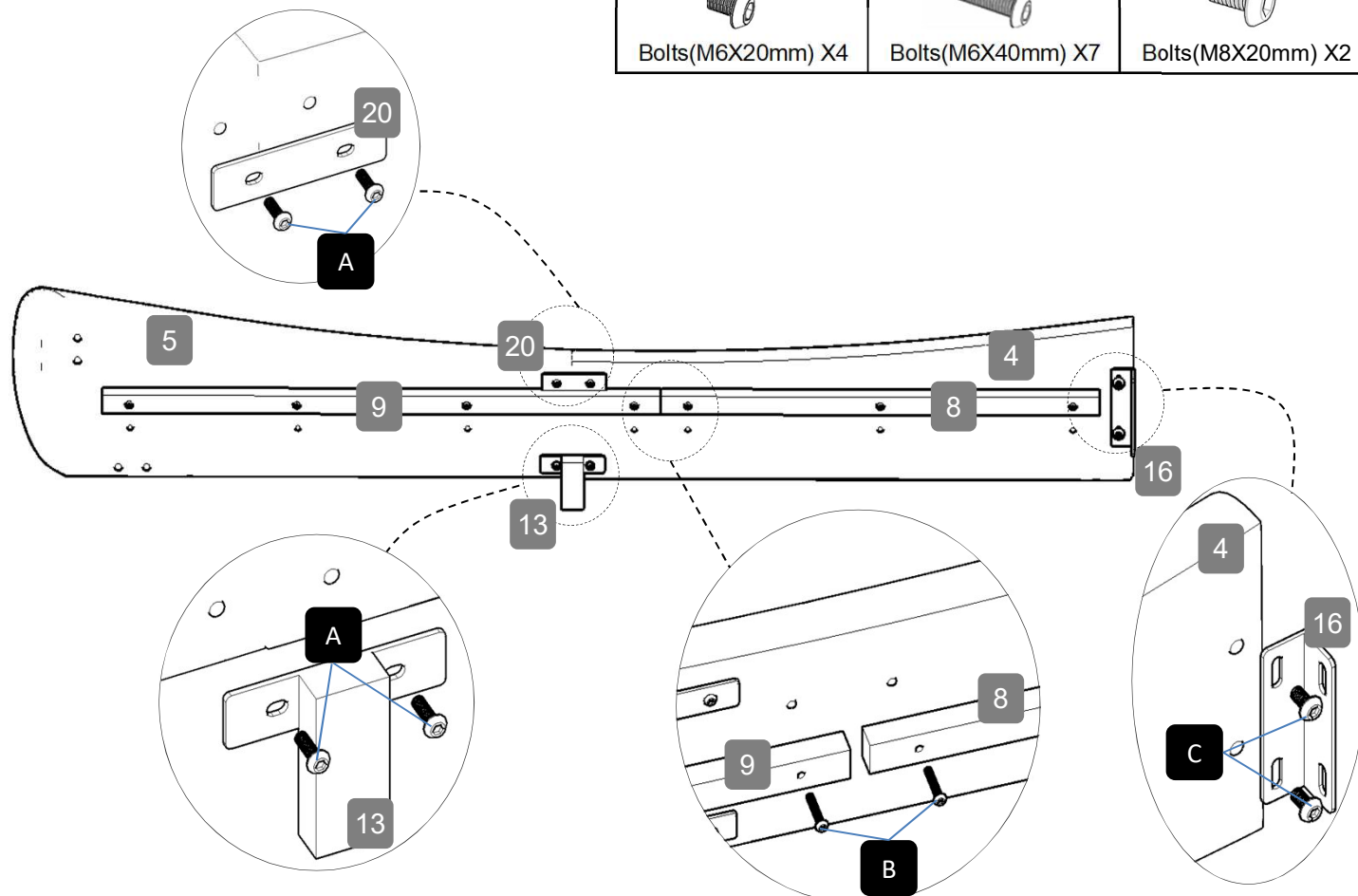
# Step4



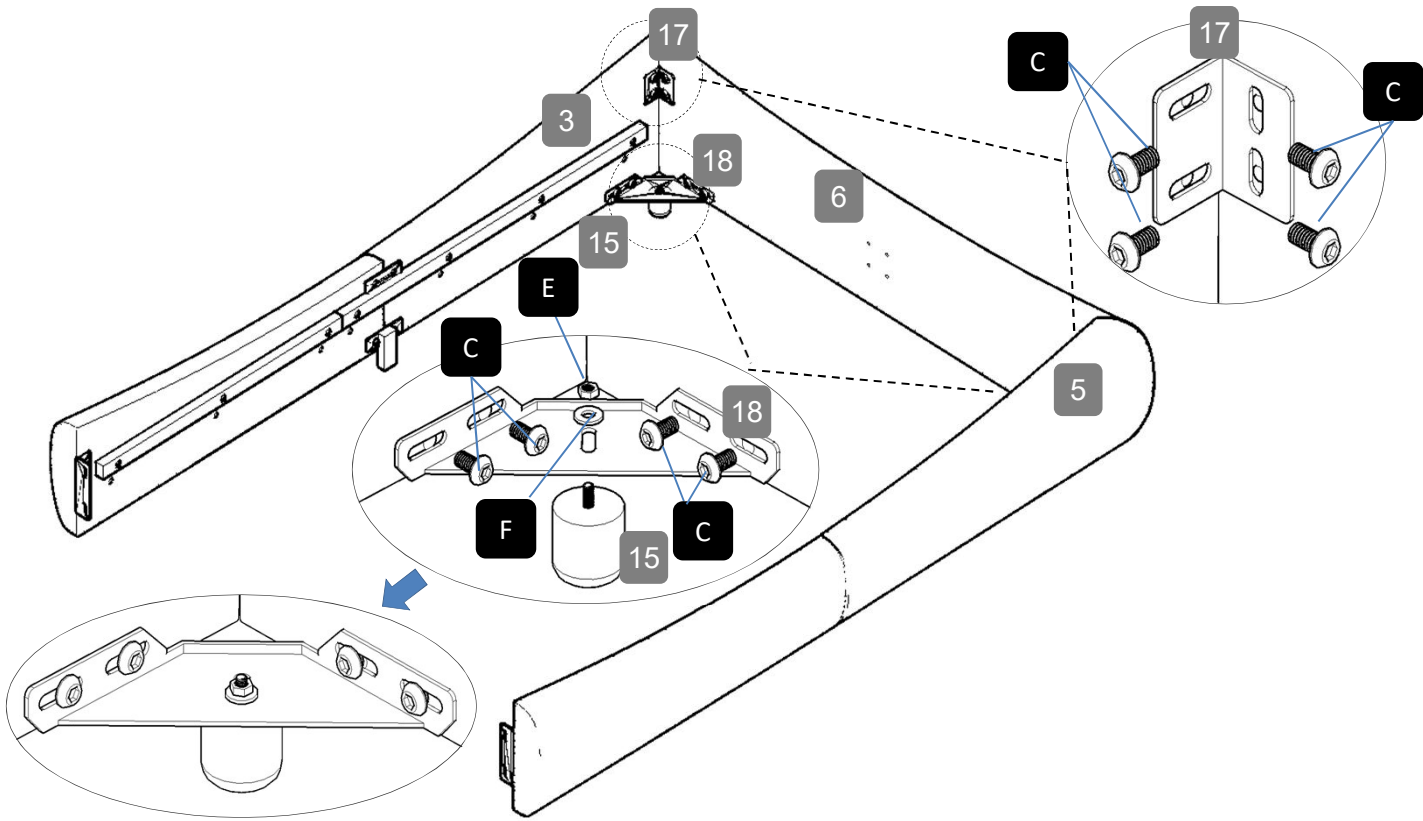

# Step5

<b>C</b>  Bolts(M8X20mm) X2	<b>E</b>  Nut(M8) X2	<b>F</b>  Flat Gasket X2
---	--	--



# Step6

<b>A</b>  Bolts(M6X20mm) X4	<b>C</b>  Bolts(M8X20mm) X4
--	--

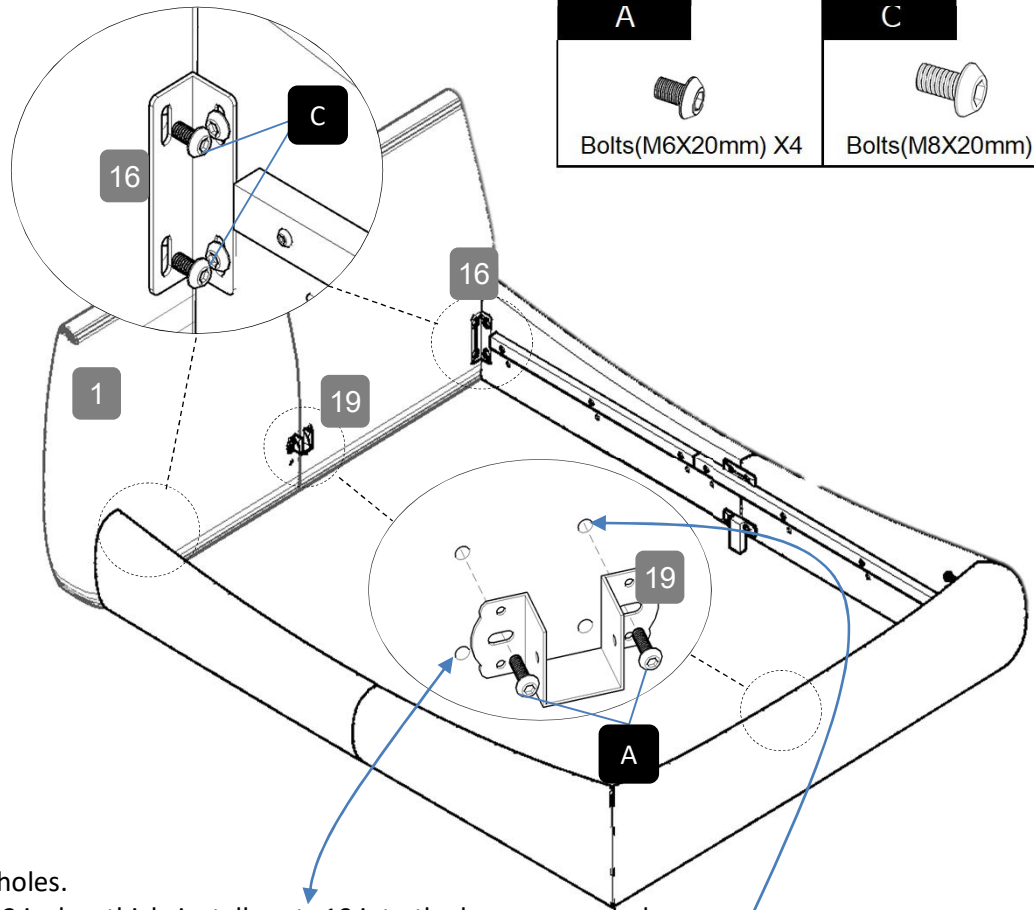

**NOTE:**

There are two rows of screw holes.  
If the mattress is more than 12 inches thick, install parts 19 into the lower screw holes.  
If the mattress is less than 12 inches thick, install parts 19 into the screw holes on the upper level

# Step7

C



Bolts(M8X20mm) X4

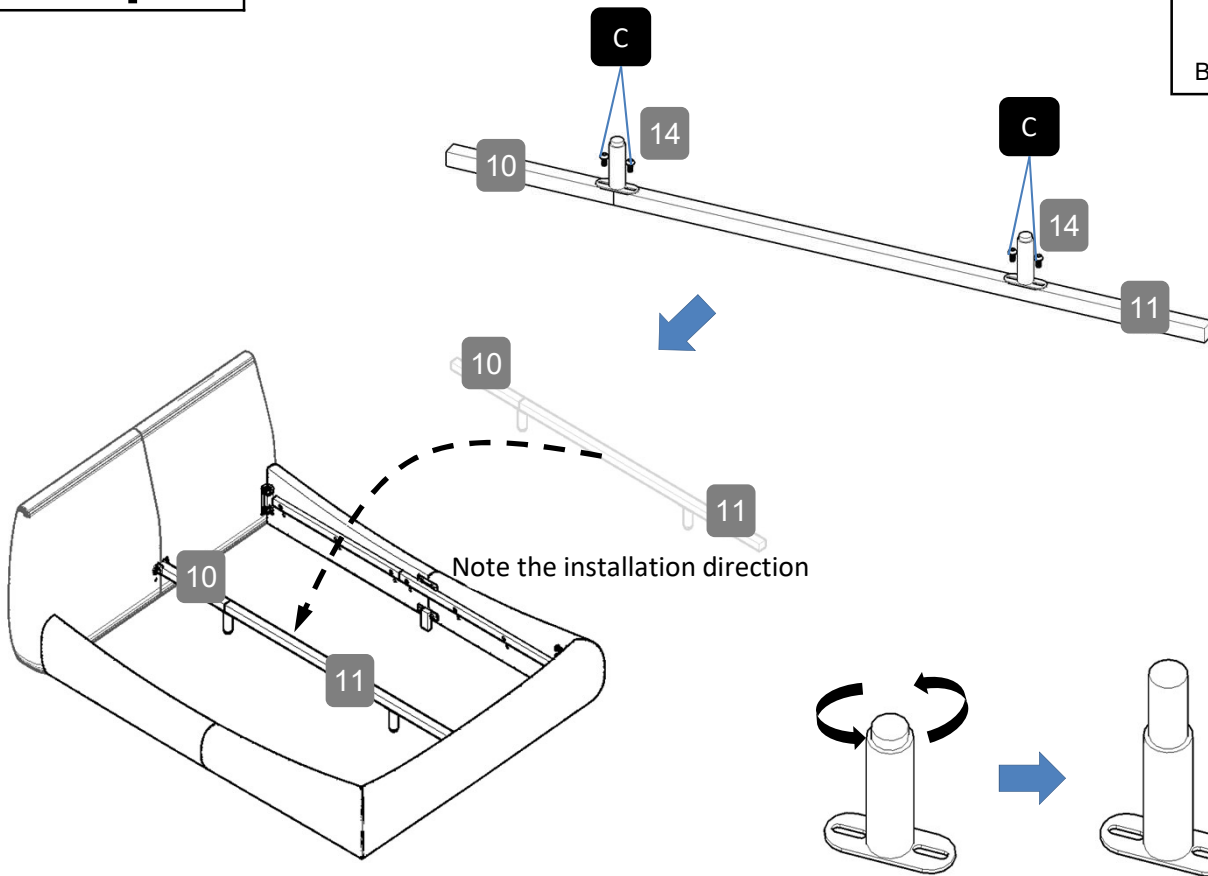

Note the installation direction

**Note:** The height of the foot can be adjusted by rotating the foot

# Step8

K



Screws (M4X20mm) X6

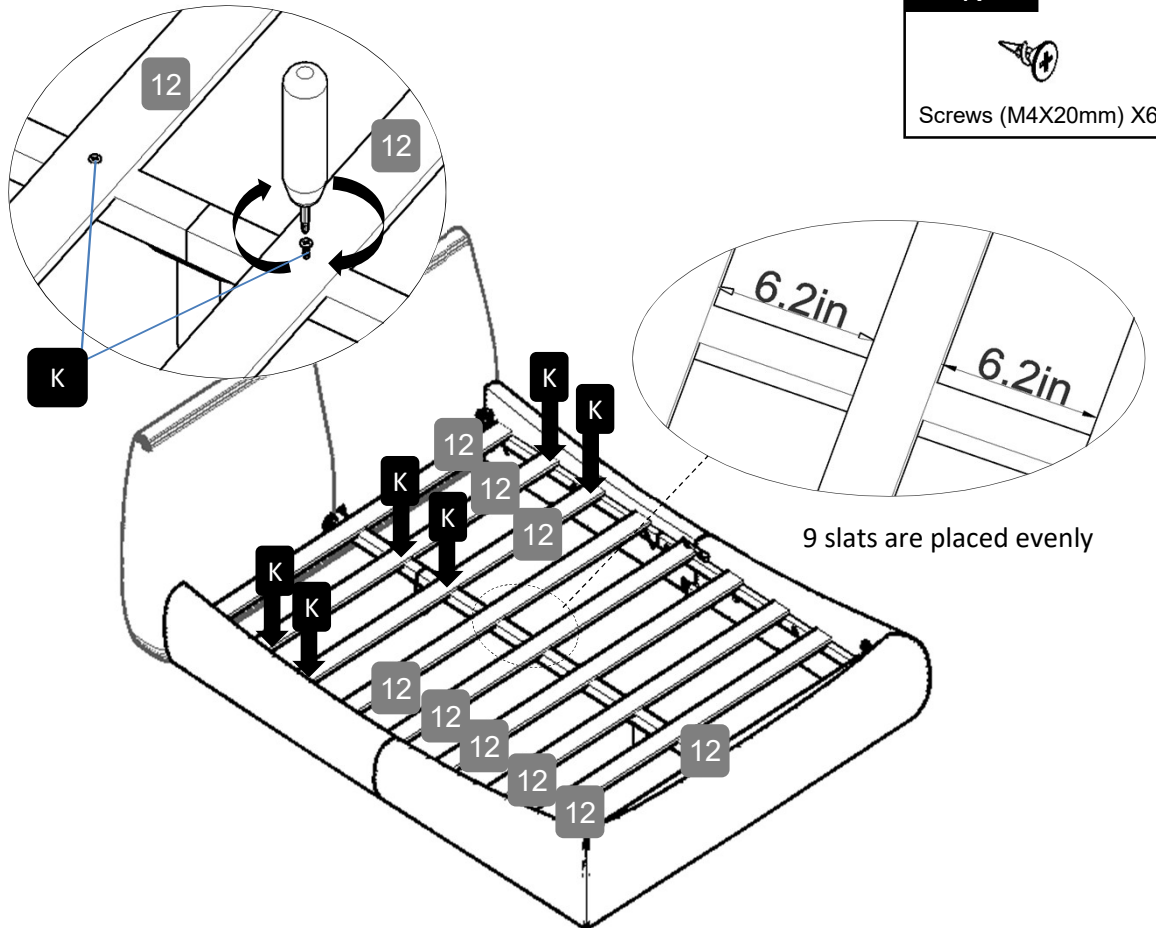

9 slats are placed evenly

## Step9

Repeat the procedure until all four pillows are fitted into the cushion

① Open the zipper and take out the pillow

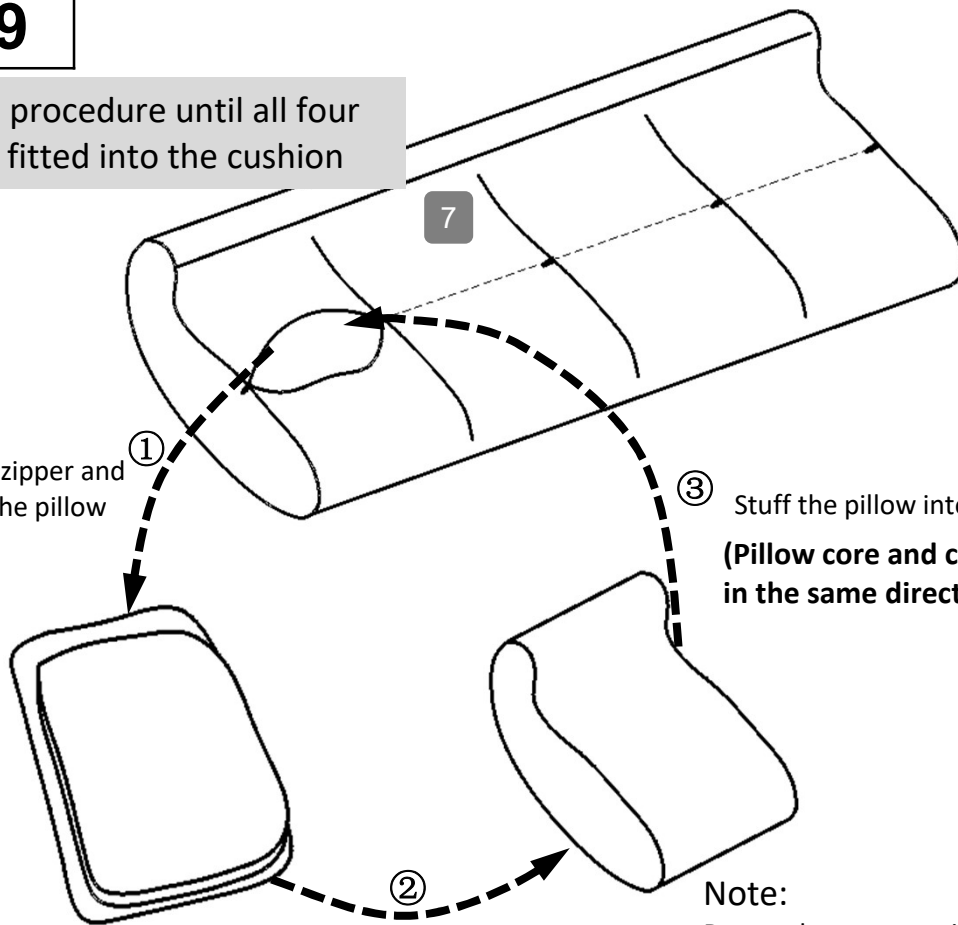

③ Stuff the pillow into the cushion  
(Pillow core and cushion should be in the same direction)

② Tear open the packing plastic bag

Note:

Due to the compression packaging of the backrest, please pat it gently until it is fluffy and leave it for 48 hours to recover 100%

## Step10

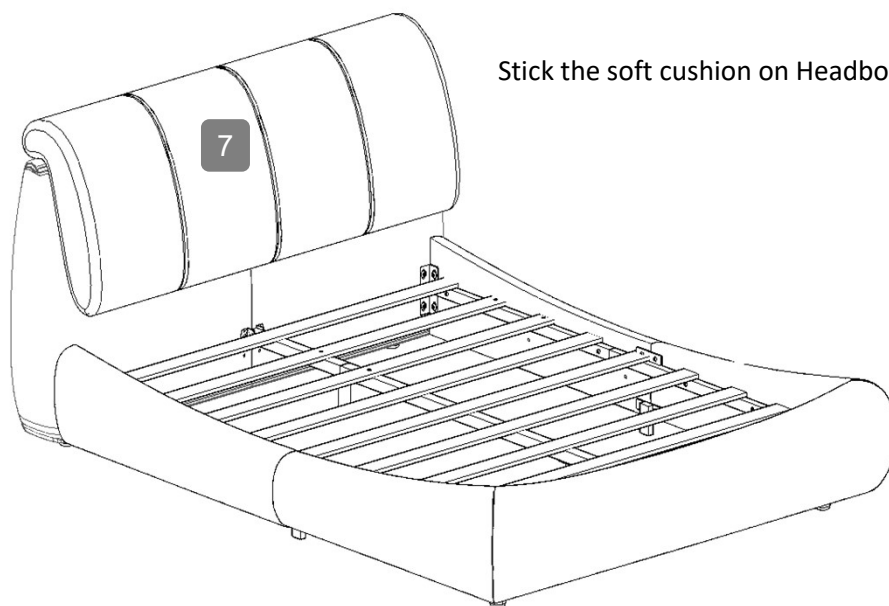

Stick the soft cushion on Headboard