

ASSEMBLY INSTRUCTIONS

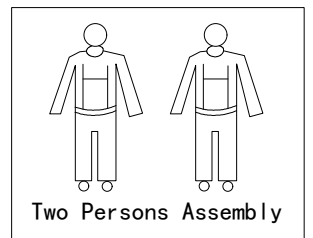

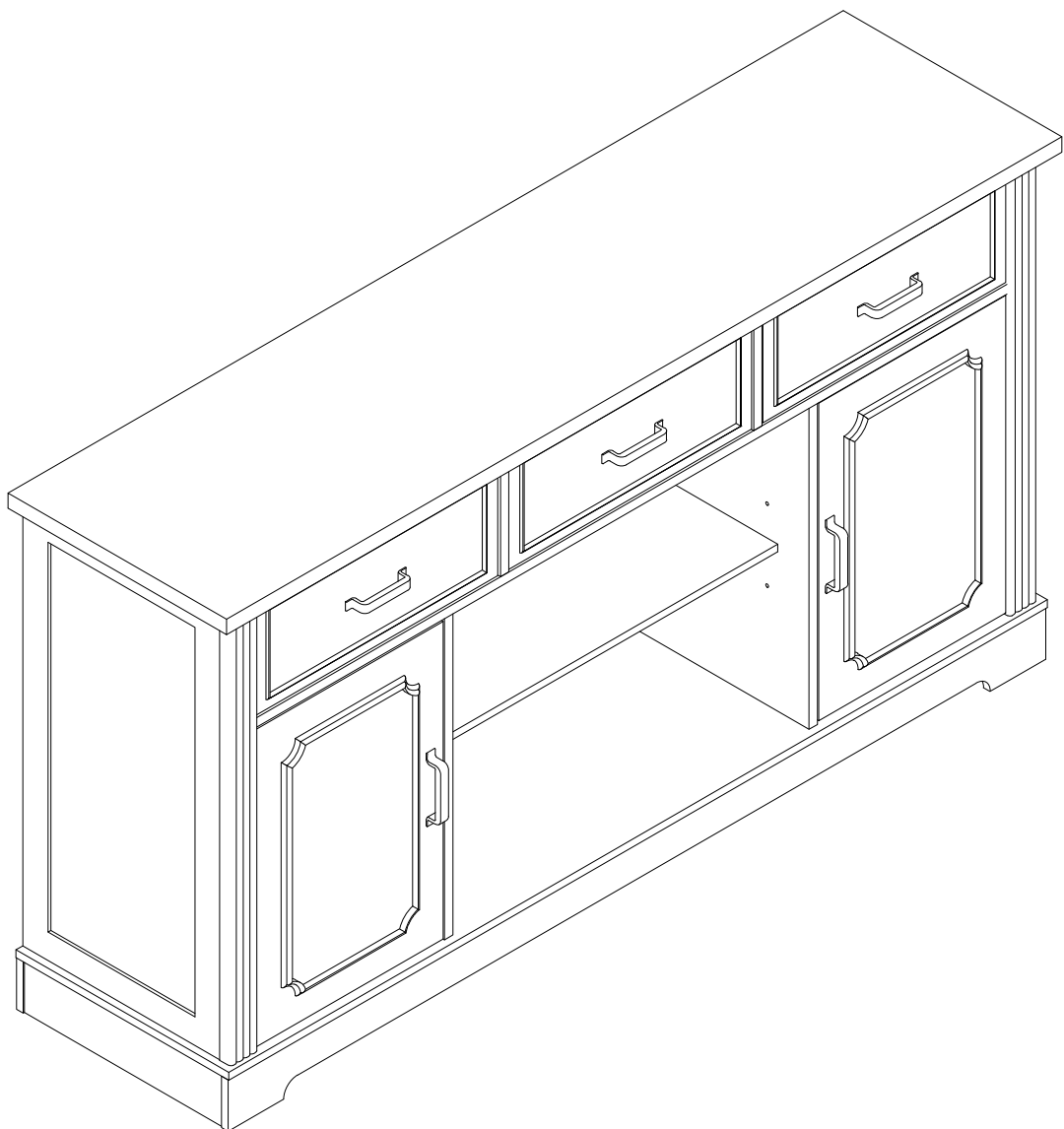

ASSEMBLY TOOLS REQUIRED (NOT INCLUDED)

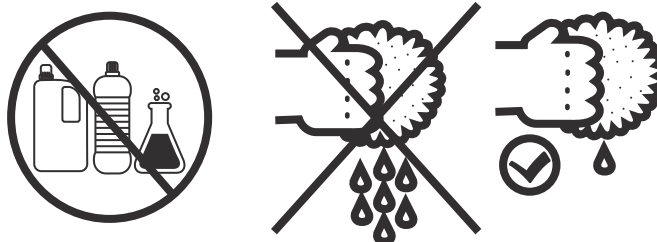
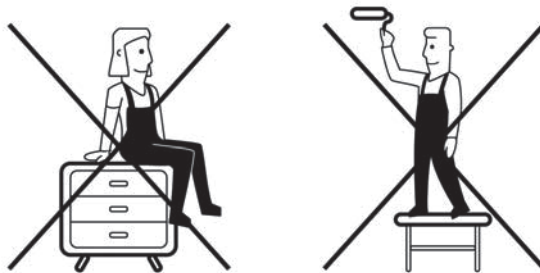
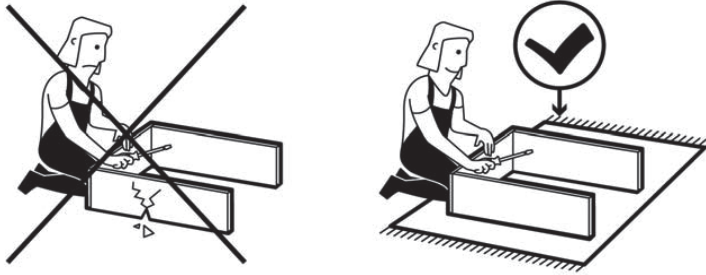
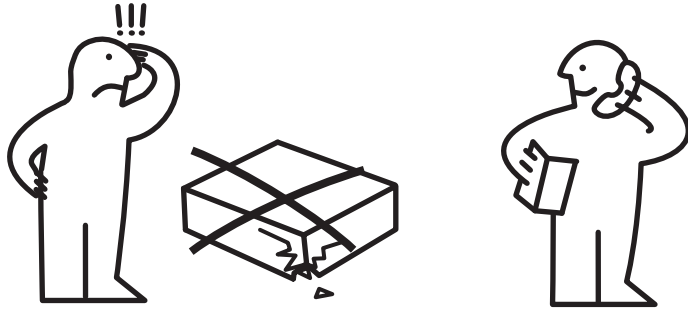
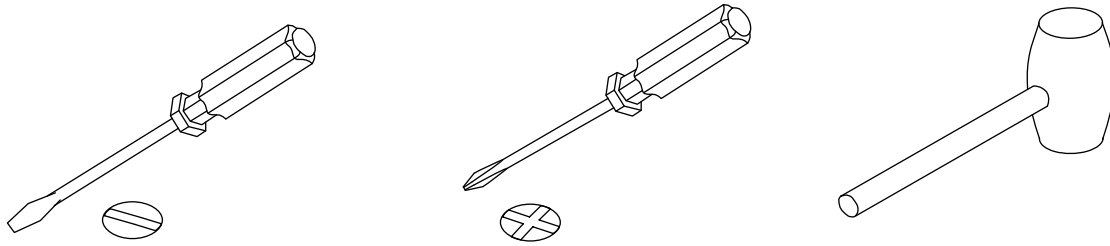

- * Before discarding packing materials, please check all parts and hardware are presented.
- * Please follow the instructions closely.
- * After few days of initial assembly, the product may have acclimated to new environment, please tighten all hardware again.

Dowel Installation

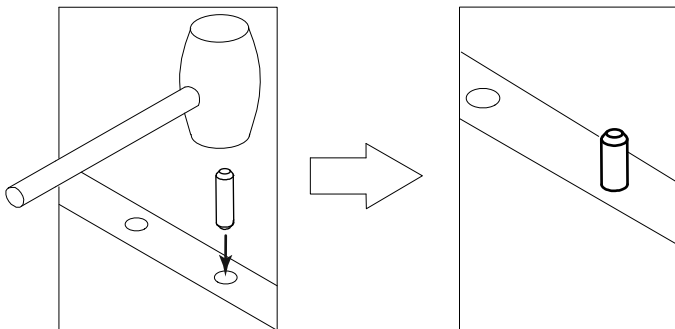

Gently tap dowel into hole with rubber mallet.

CAM-LOCK

Tighten until shoulder is flush with panel. Do not overtighten or undertighten

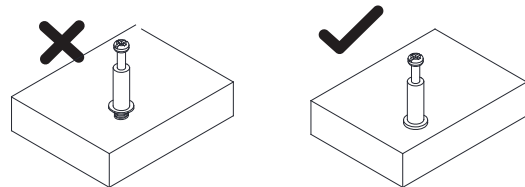
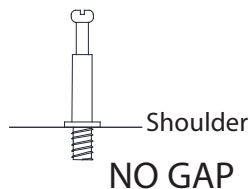

WHEN FITTING CAMS



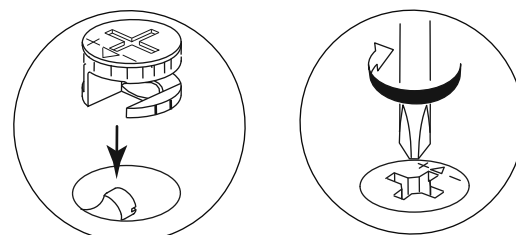
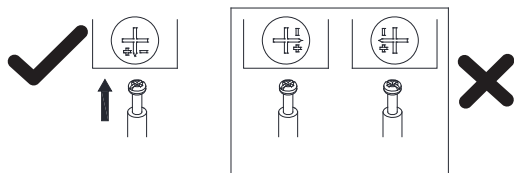



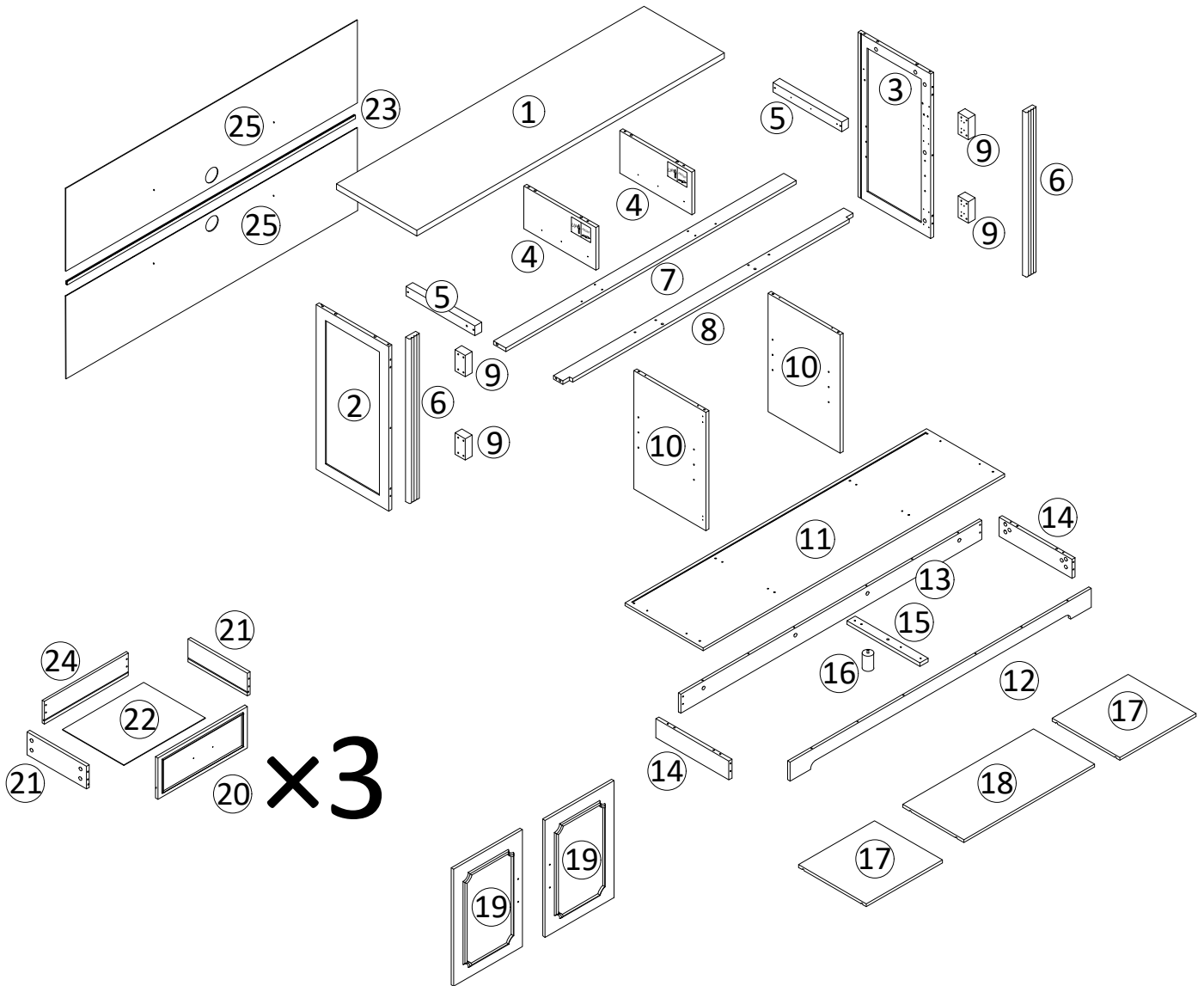



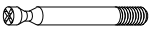

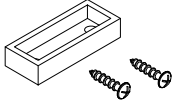
ENSURE STARTING POSITION IS CORRECT BEFORE YOU INSERT CONNECTING CAM-PILLAR
TURN CLOCKWISE UNTIL SECURE

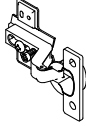

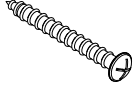
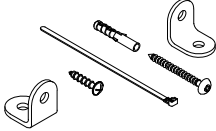
Laying out all the parts and hardware and identifying each part as shown below. It may help you when you assemble the item.

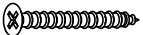
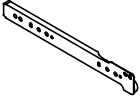

① ×1	② ×1	③ ×1	④ ×2	⑤ ×2	⑥ ×2
⑦ ×1	⑧ ×1	⑨ ×4	⑩ ×2	⑪ ×1	⑫ ×1
⑬ ×1	⑭ ×2	⑮ ×1	⑯ ×1	⑰ ×2	⑱ ×1
⑲ ×2	⑳ ×3	㉑ ×6	㉒ ×3	㉓ ×1	㉔ ×3
㉕ ×2					

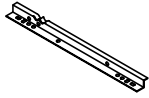
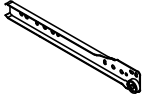
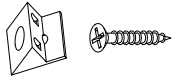
A	×62+2(Spare)	B	×62+3(Spare)	C	×44+2(Spare)	D	×4	E	×5
									
Ø6×27mm		Ø15×9.5mm		Ø6×30mm		FA3×12mm		M6×15L-φ15×6T	
F	×36+2(Spare)	G	×4	H	×12+2(Spare)	I	×24+2(Spare)	J	×24+2(Spare)
									
FA3×12mm		Ø26mm-L		M5×14mm		FA4×12mm		FA4×25mm	
K	×2	L	×4+1(Spare)	M	×5	N	×10+2(Spare)	O	×16+2(Spare)
									
4×40mm/4×12mm		FA3×12mm		130mmH		M4×16mm		FA4×40mm	
CL	×3	DL	×3	DR	×3	CR	×3	P	×8+1(Spare)
									
300mm		300mm		300mm		300mm		FA3×14mm	

1

Turn the screws vertically
from slow to fast.

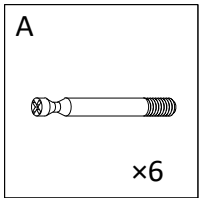
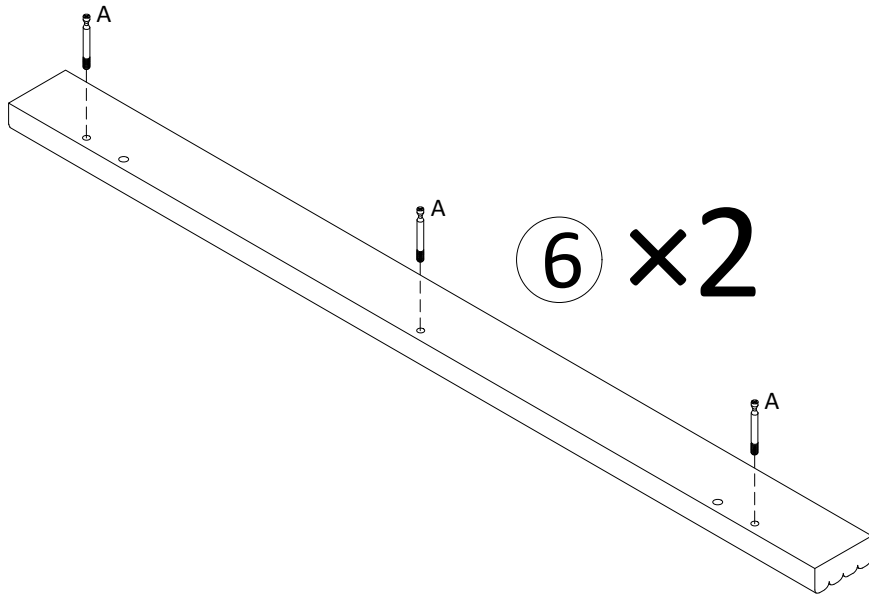

2

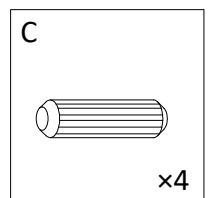
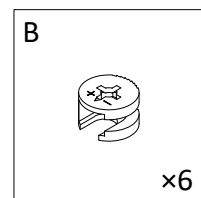
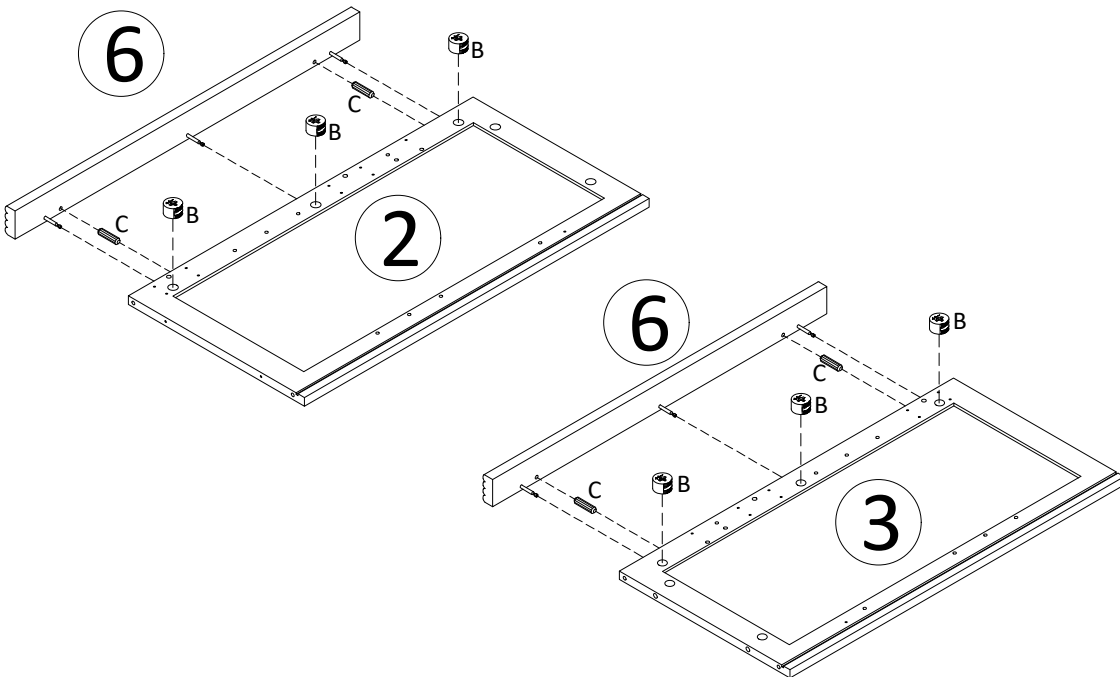

3

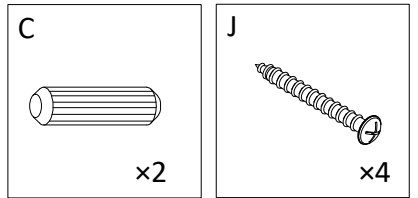
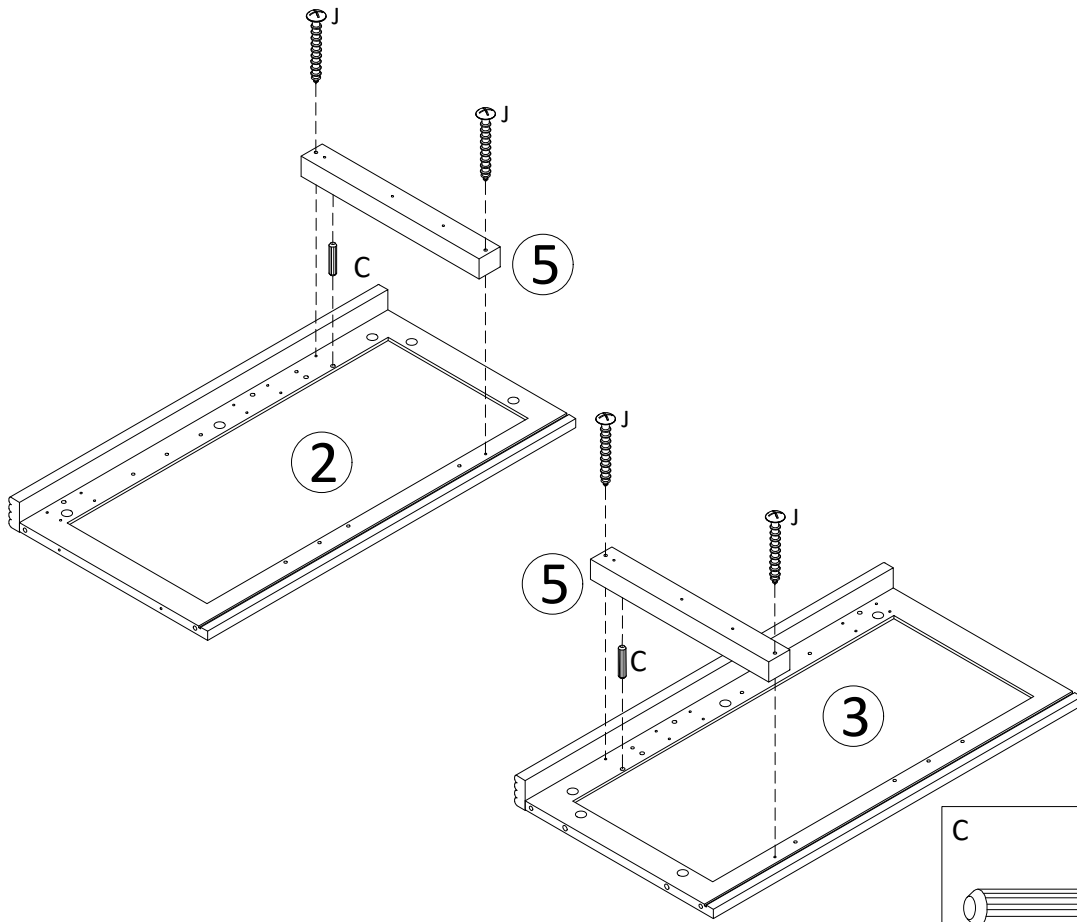

4

Turn the screws vertically from slow to fast.

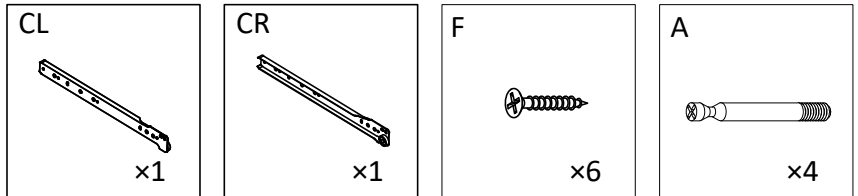
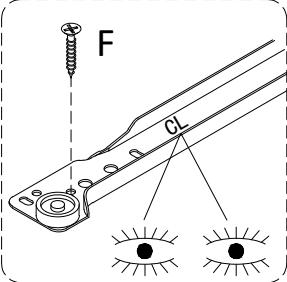
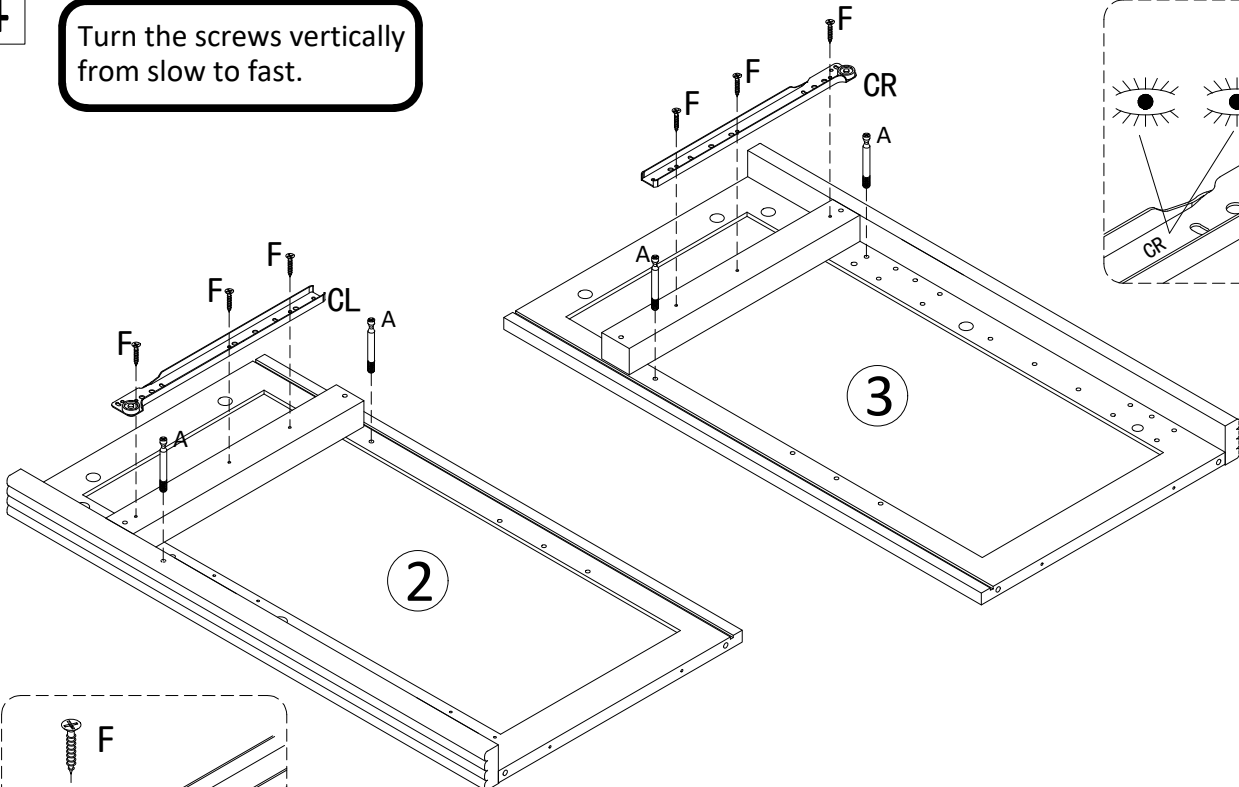

5

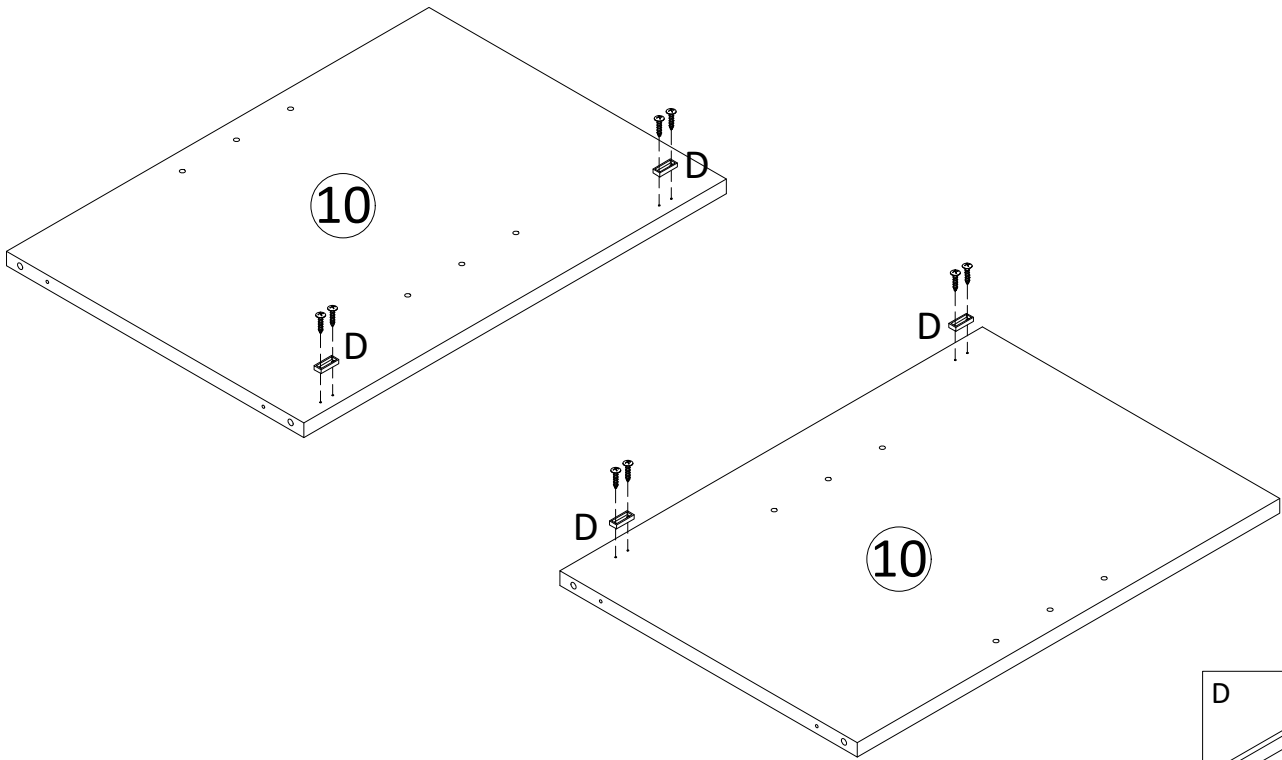

6

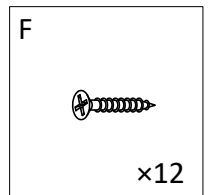
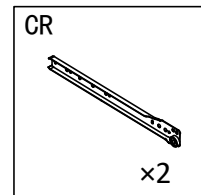
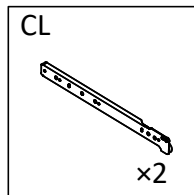
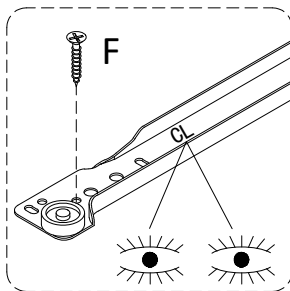
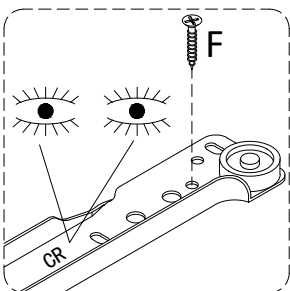
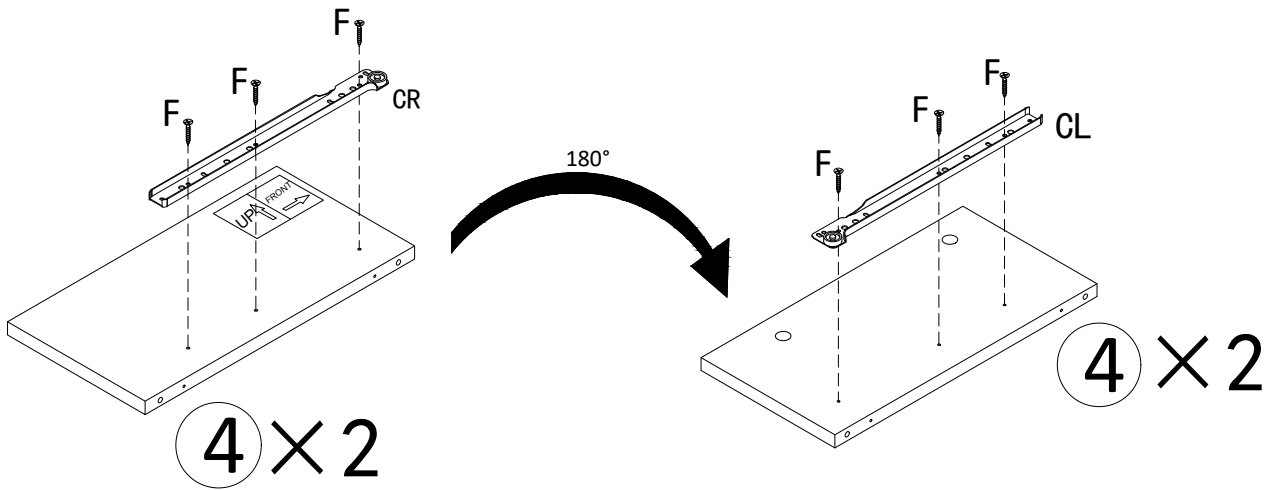

7

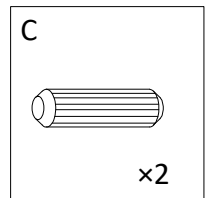
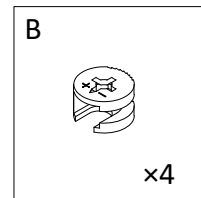
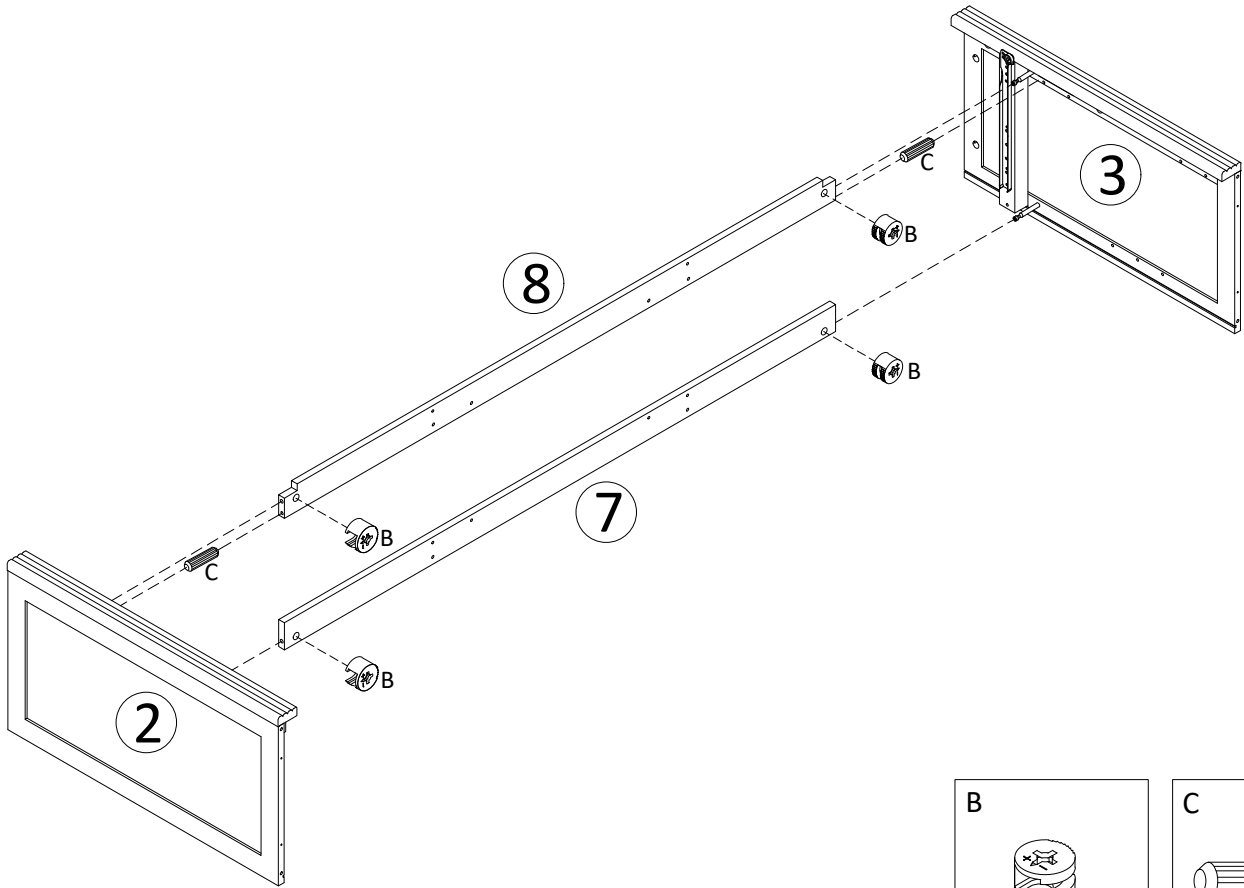

8

Note the directions in part 10.

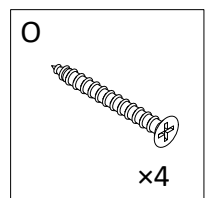
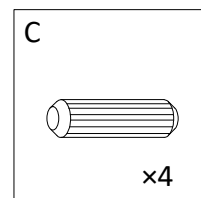
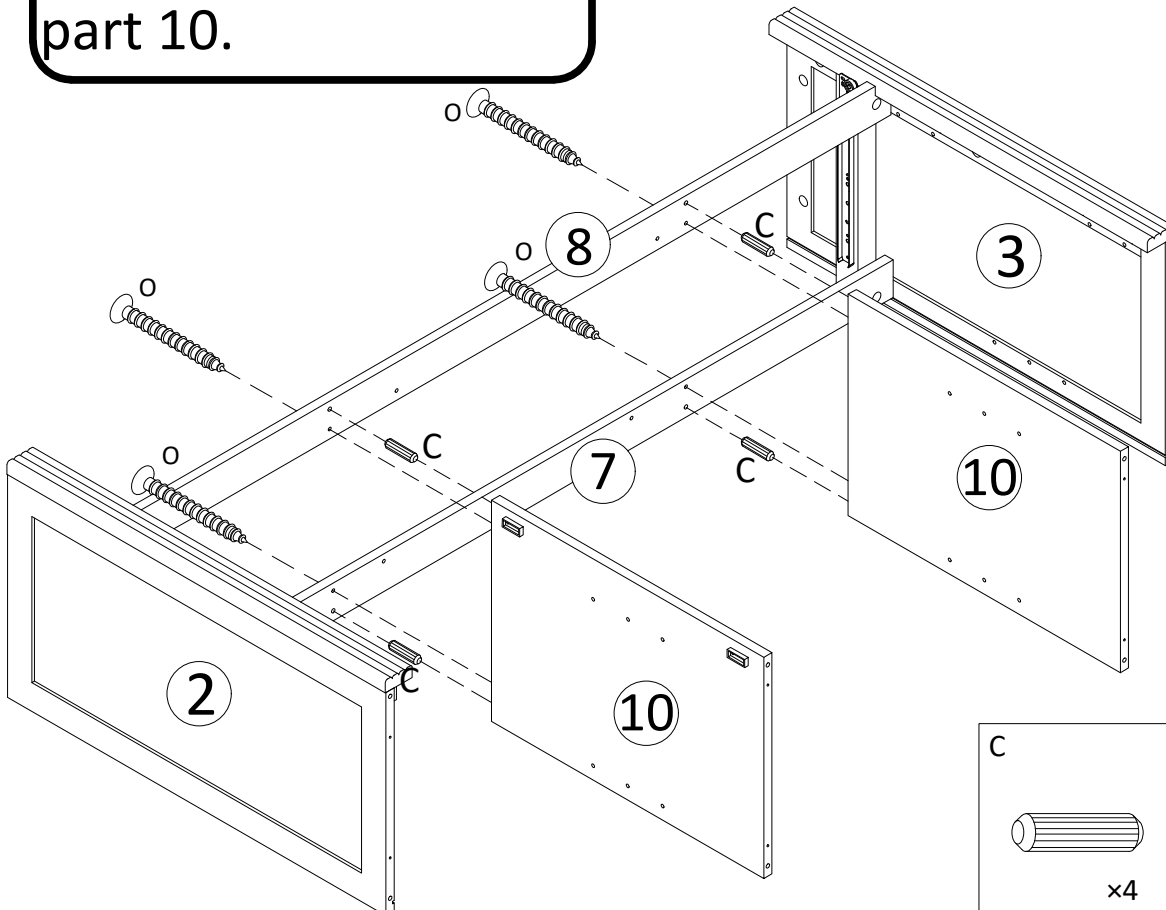

9

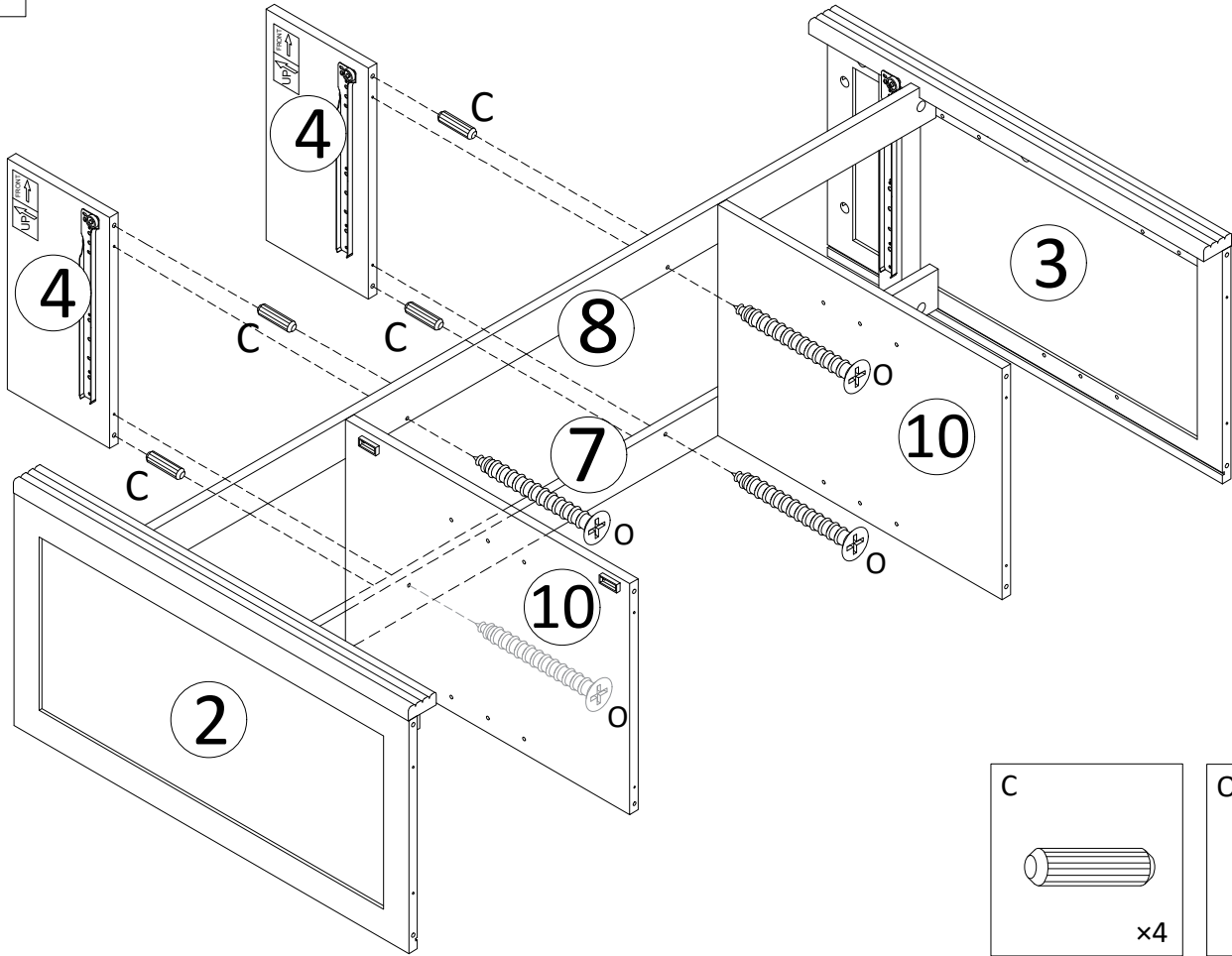

10

Turn the screws vertically from slow to fast.

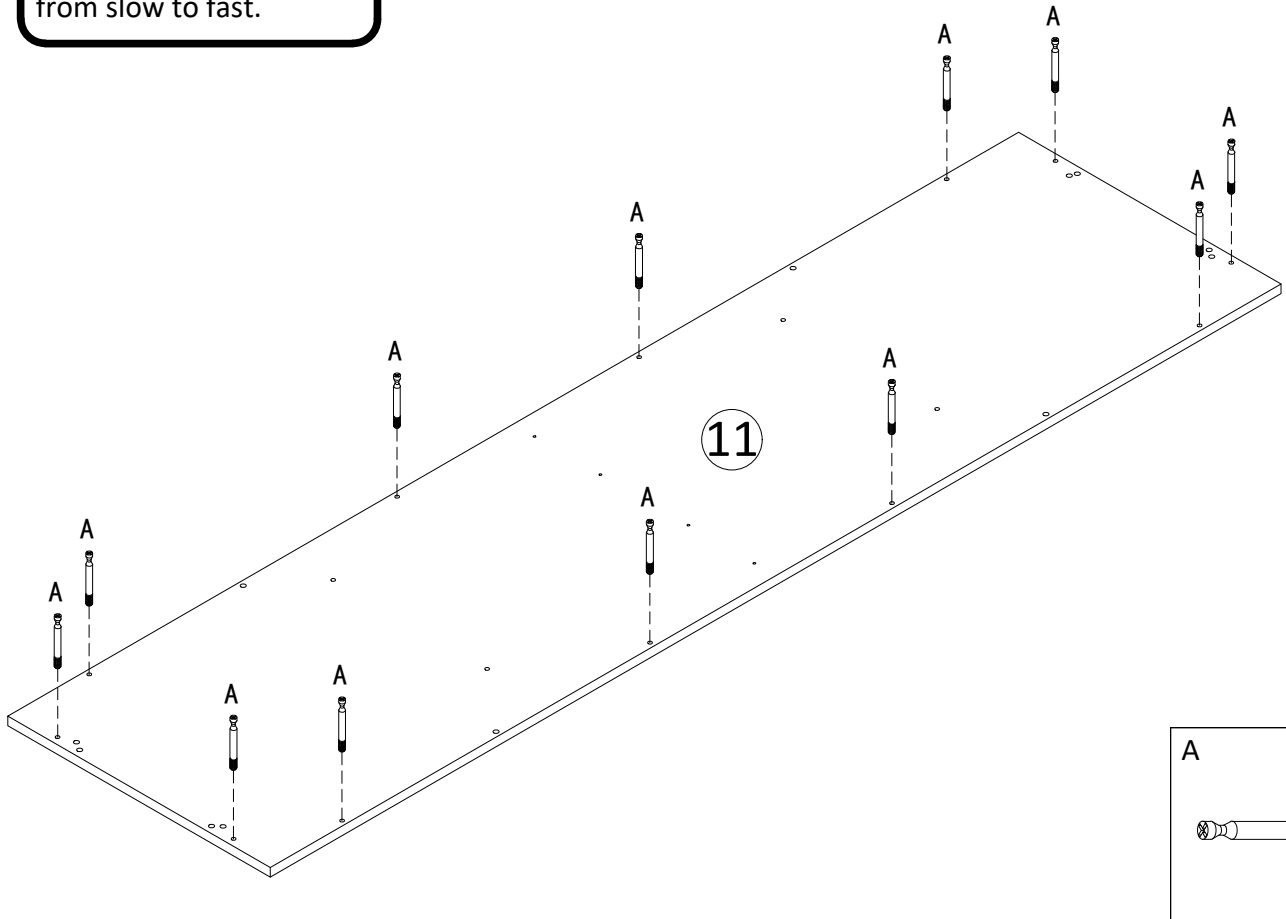

11

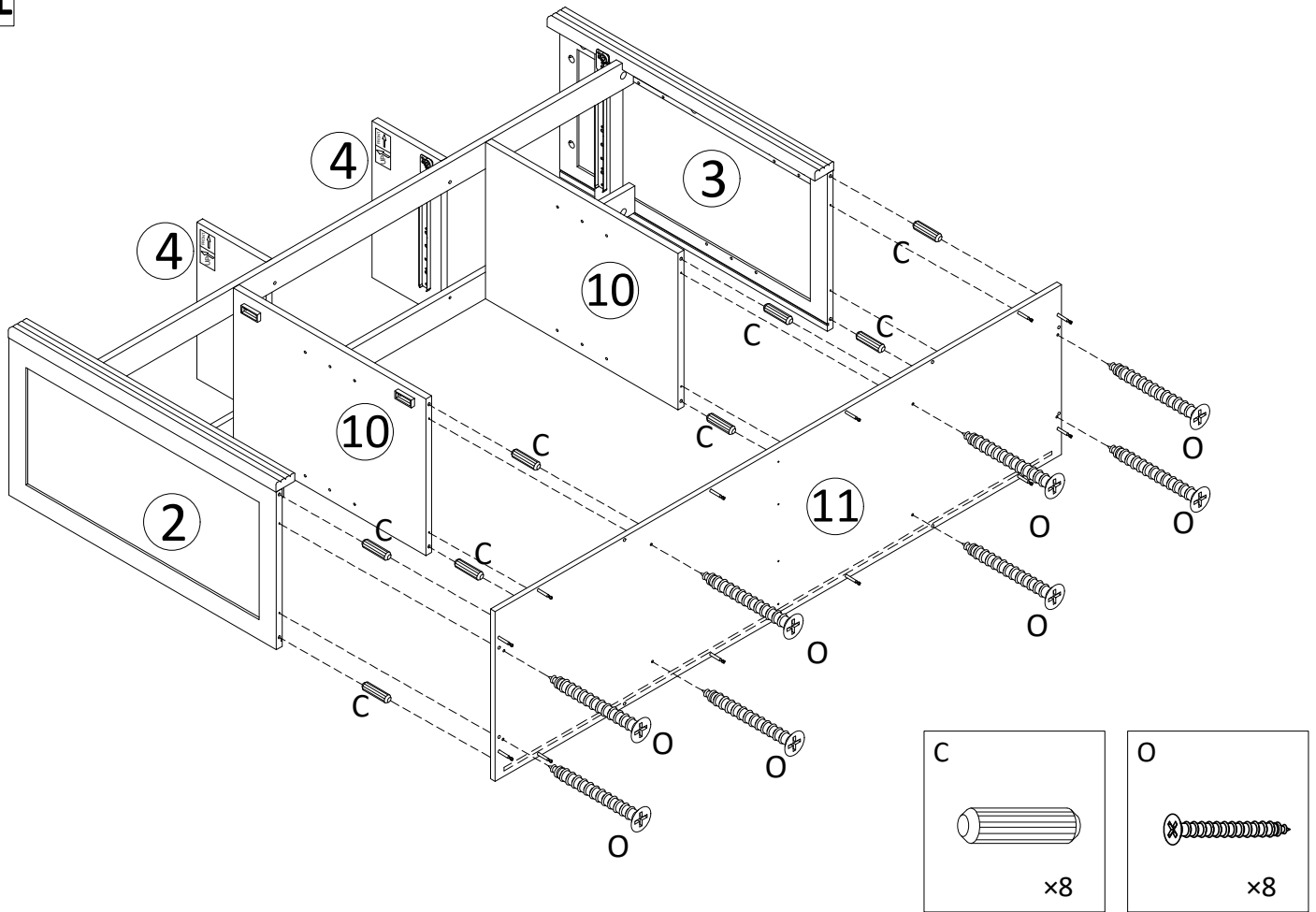

12

Turn the screws vertically from slow to fast.

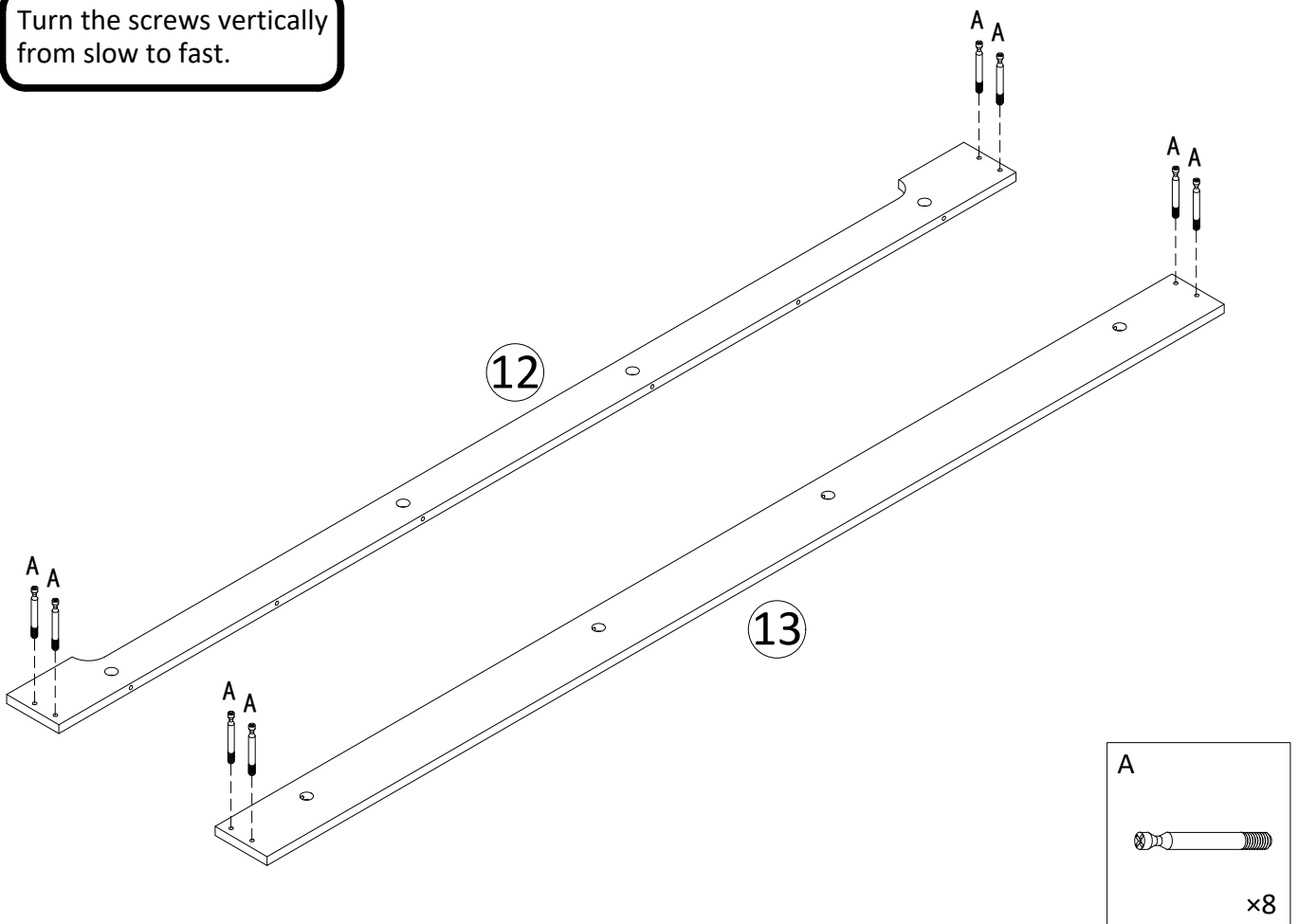

13

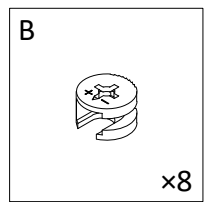
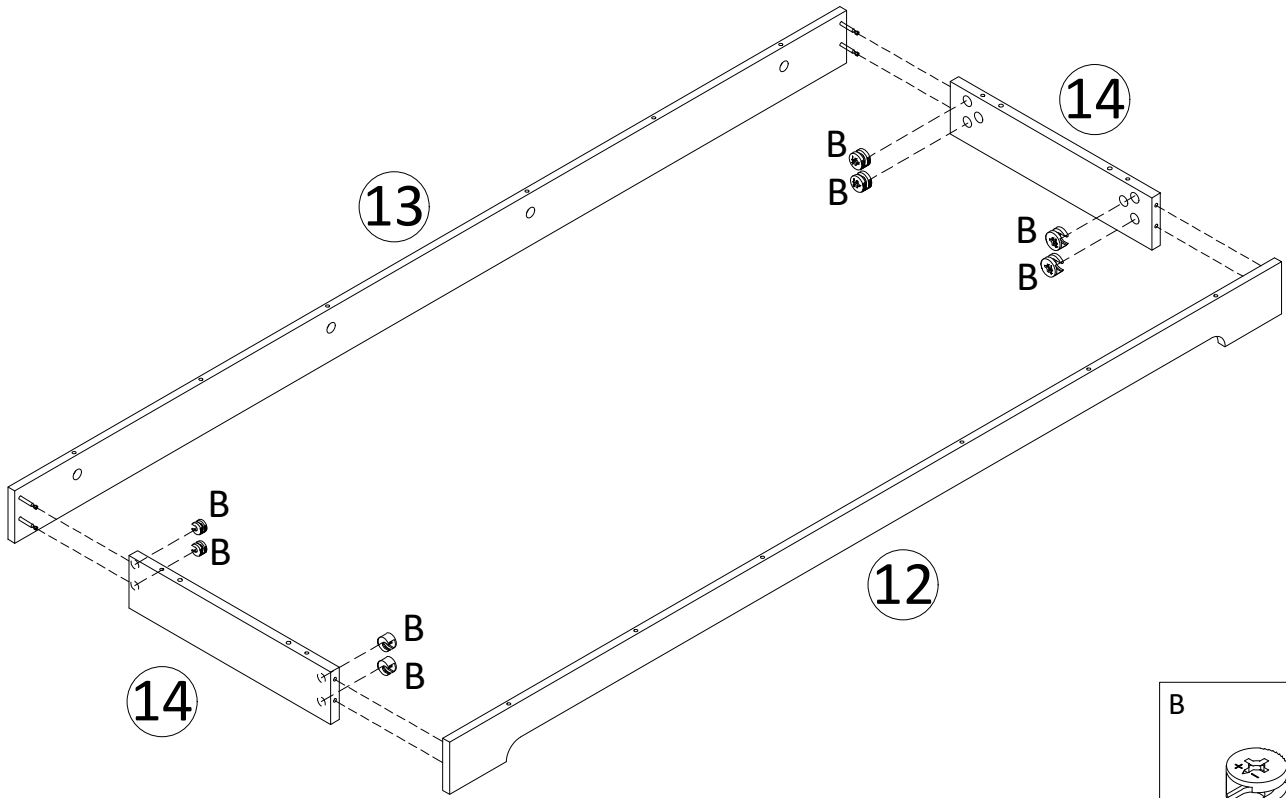

14

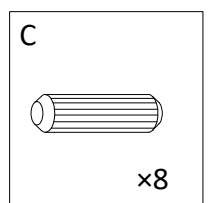
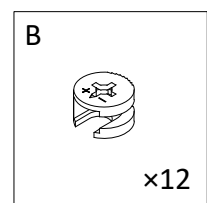
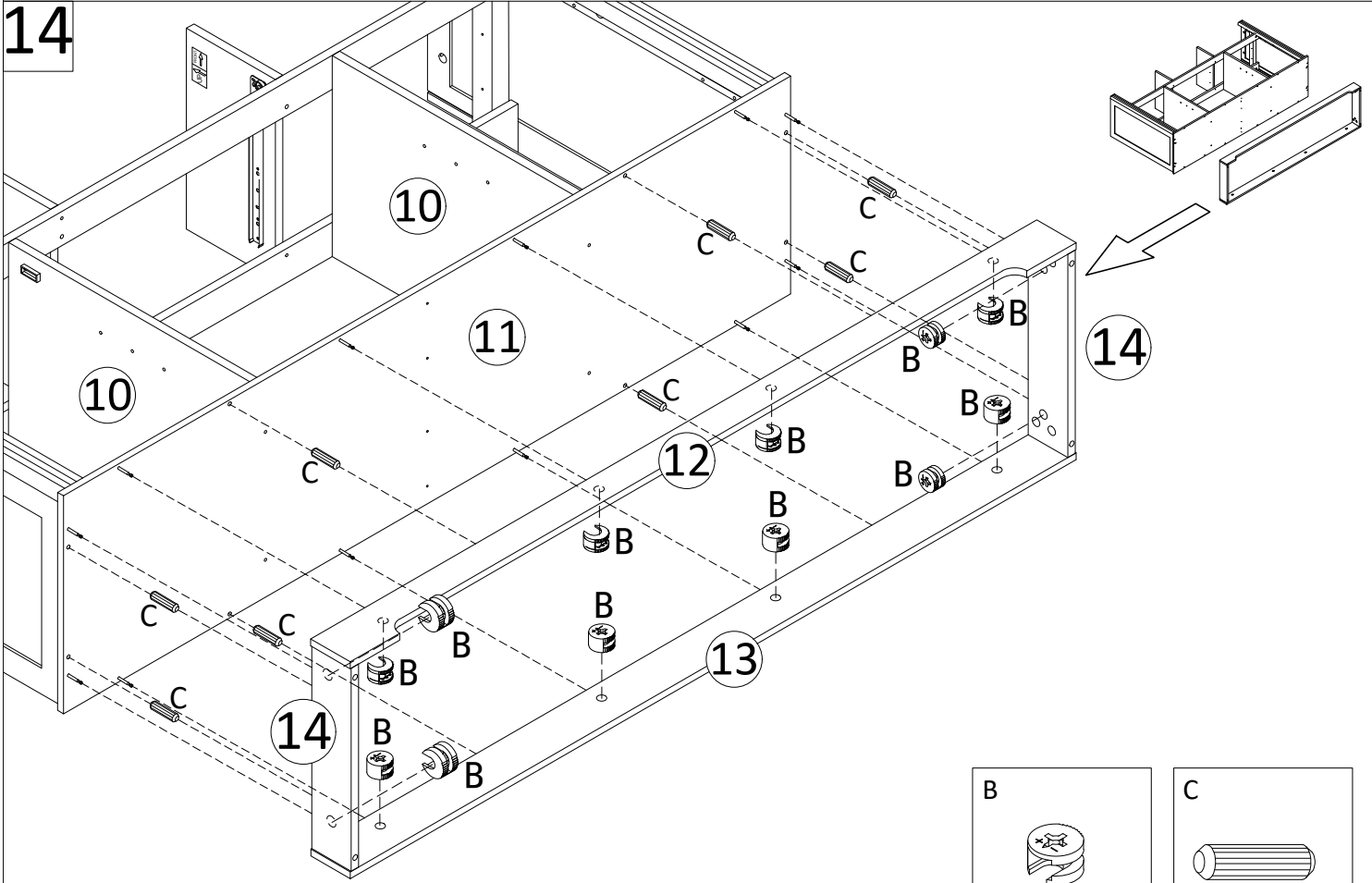

15

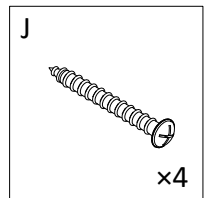
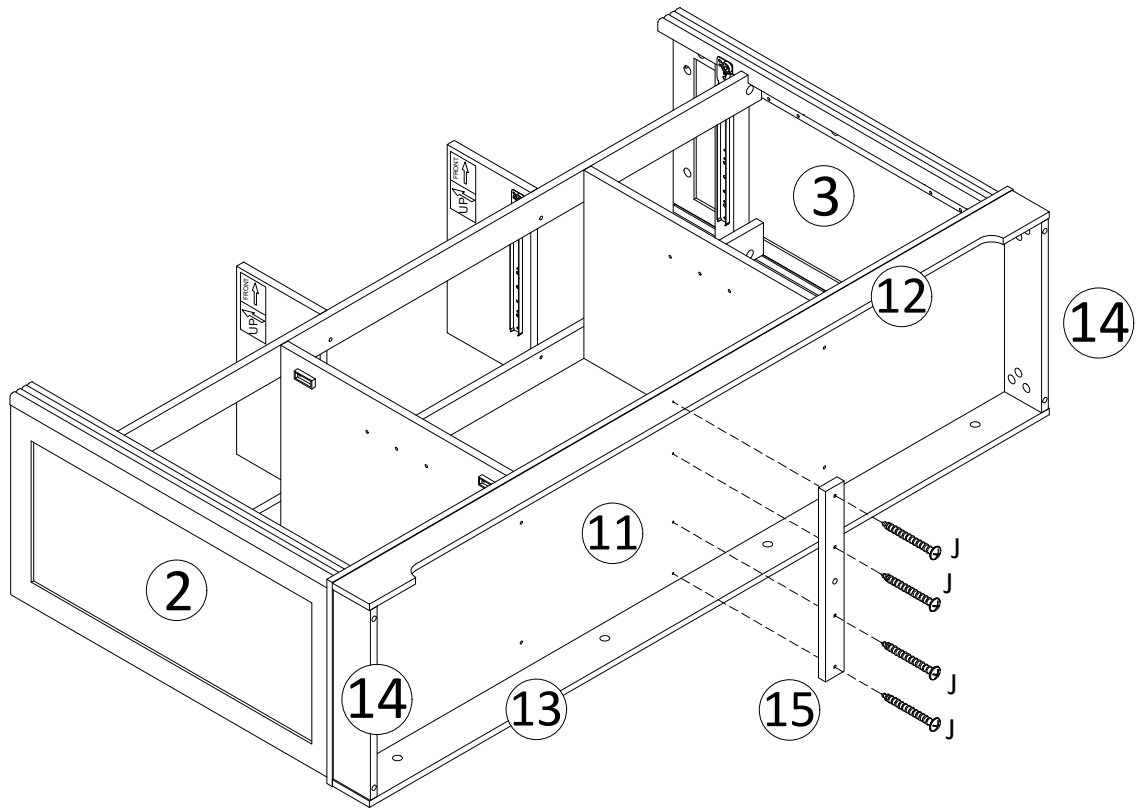

16

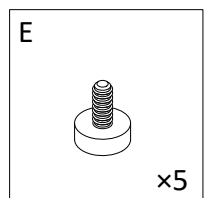
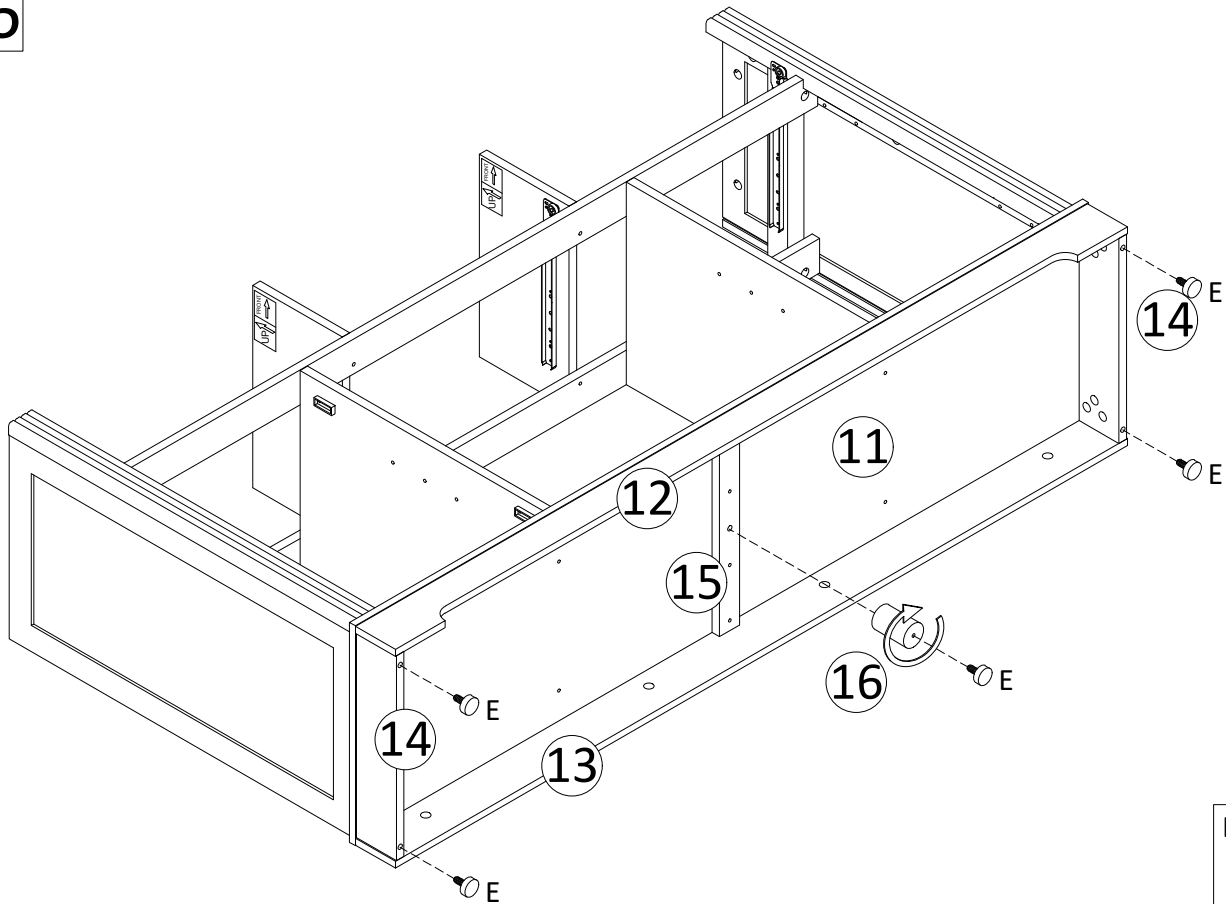

17

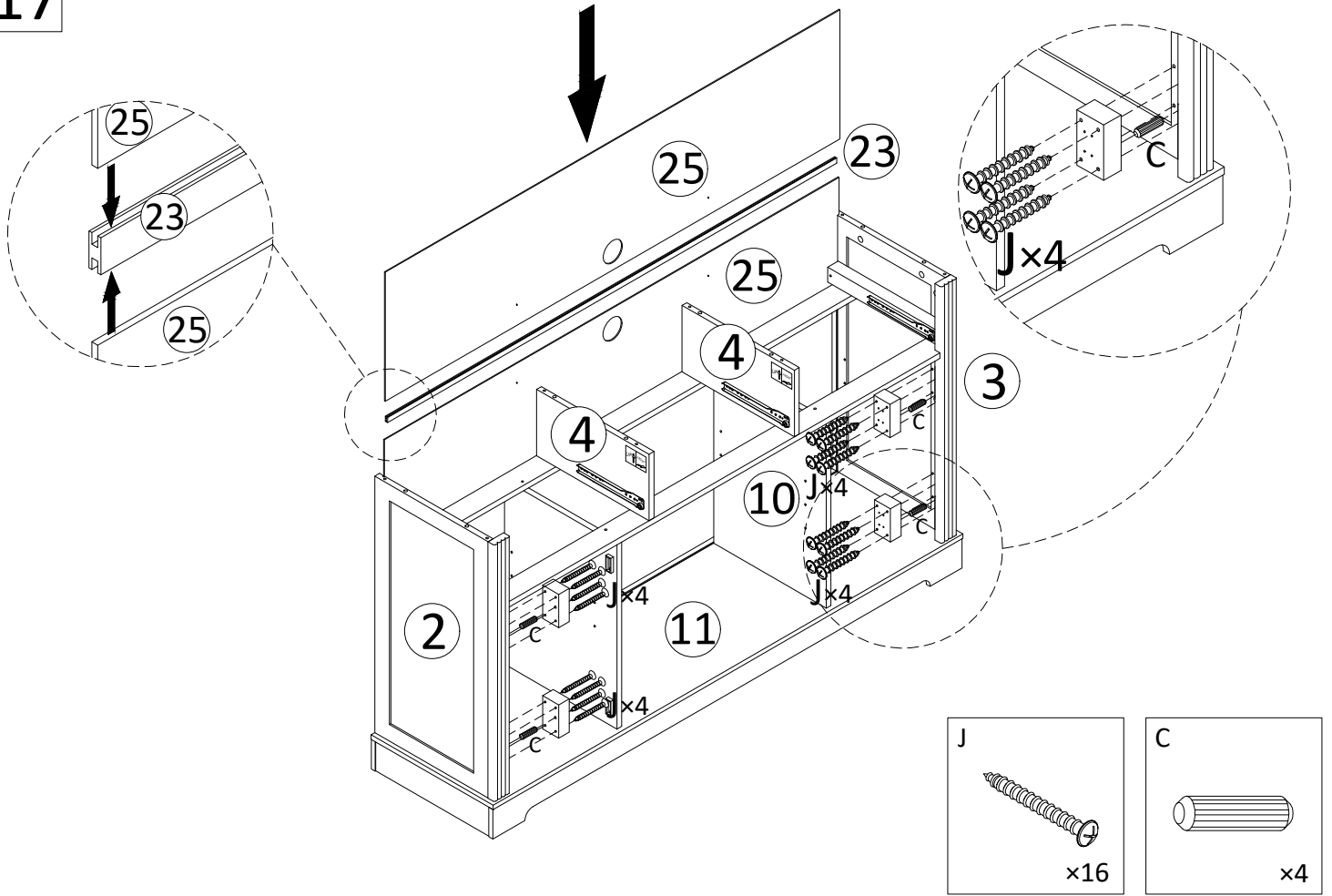

18

Turn the screws vertically from slow to fast.

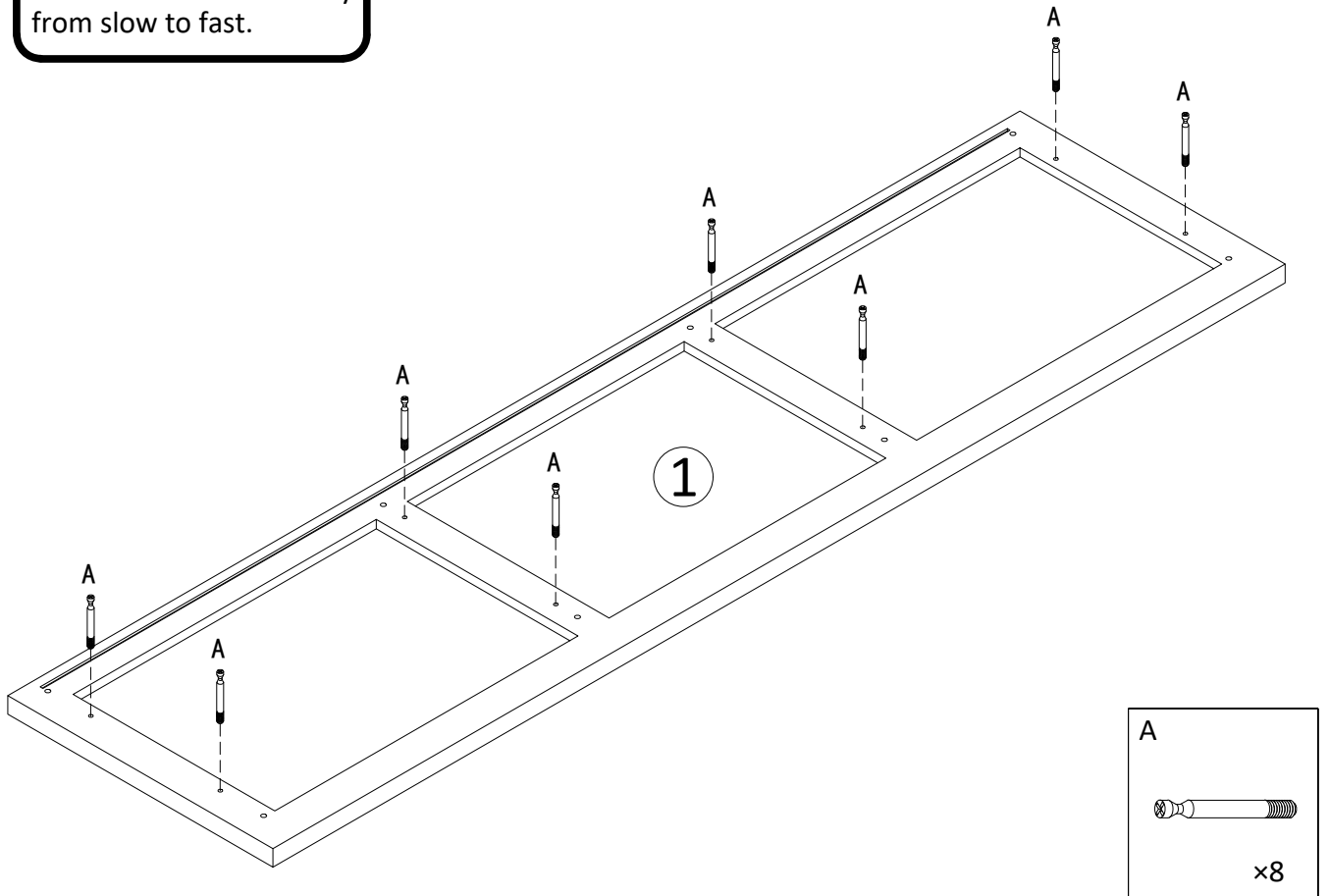

19

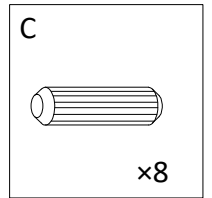
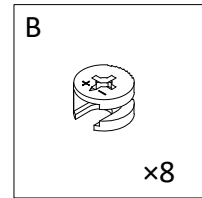
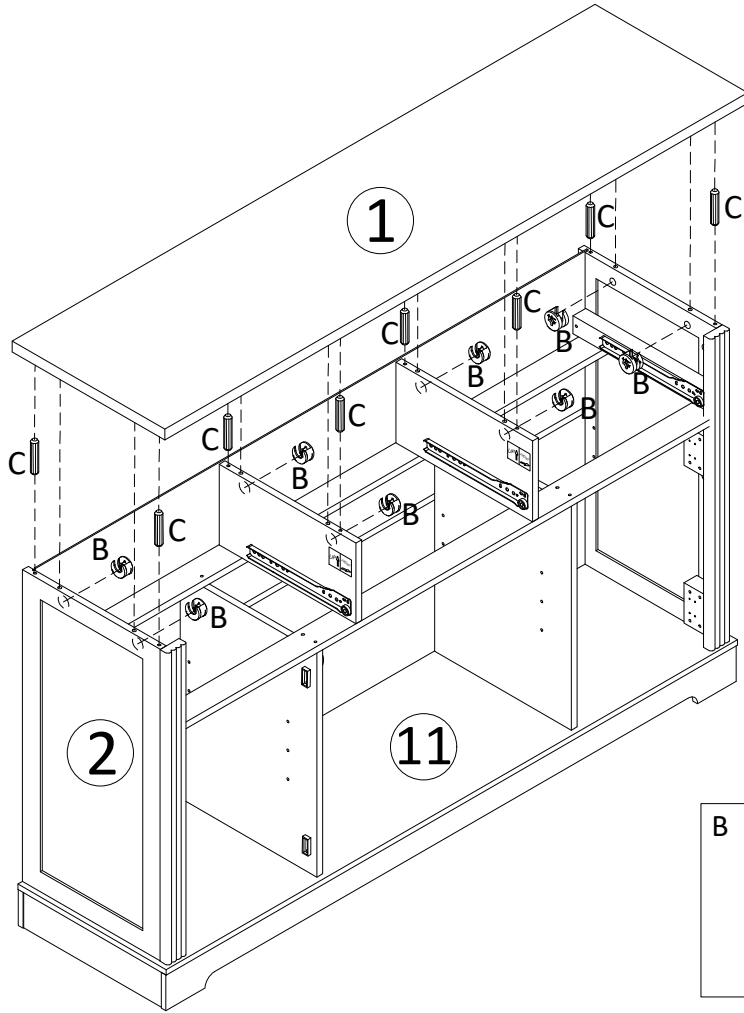

20

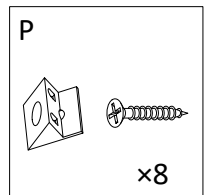
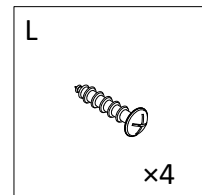
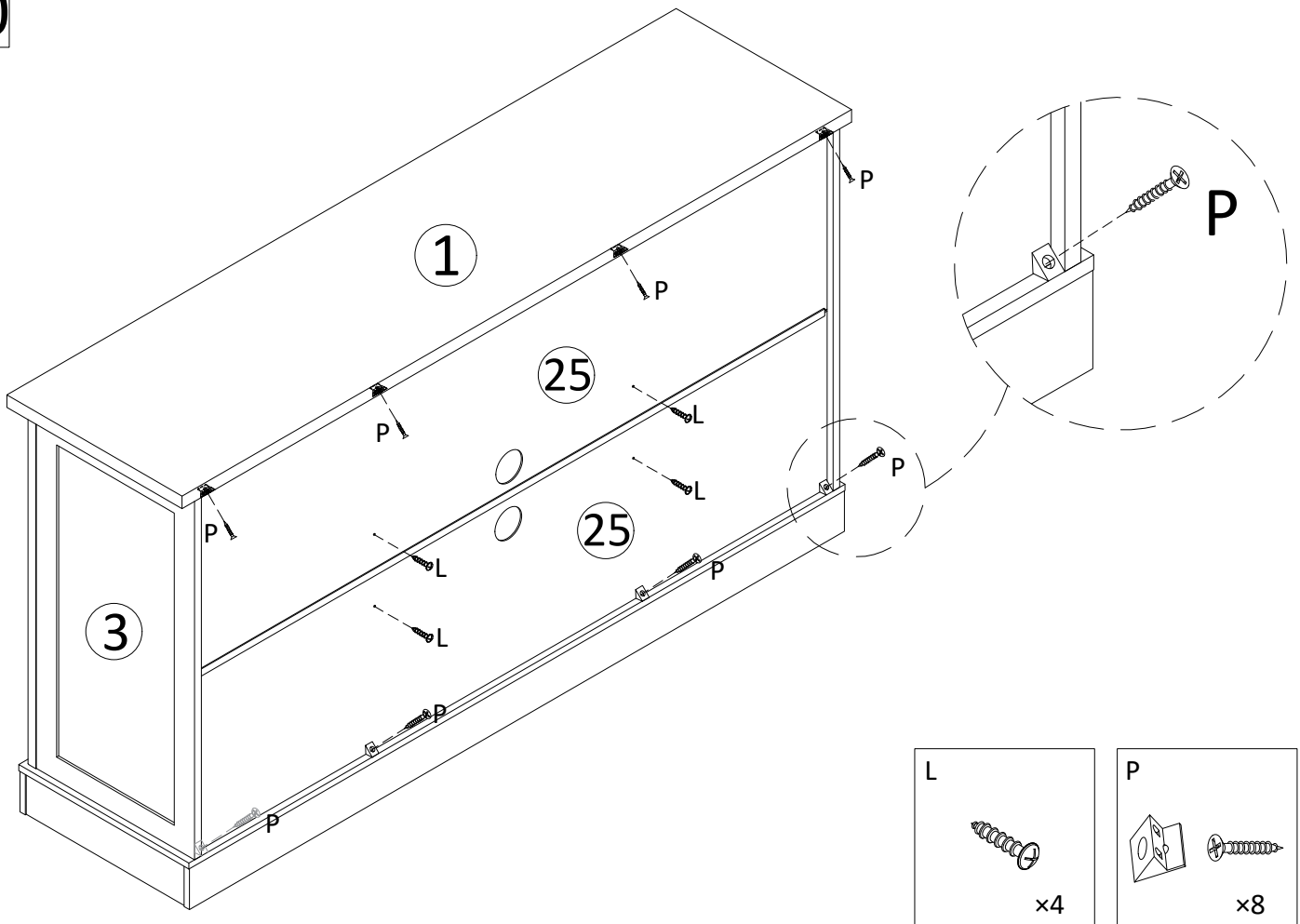

Turn the screws vertically from slow to fast.

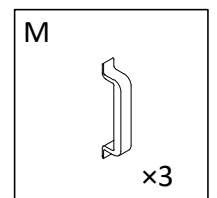
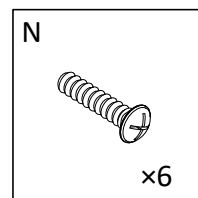
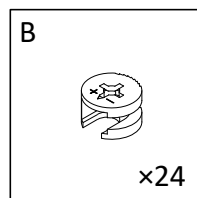
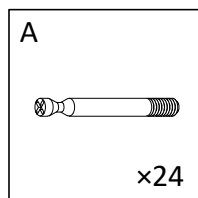
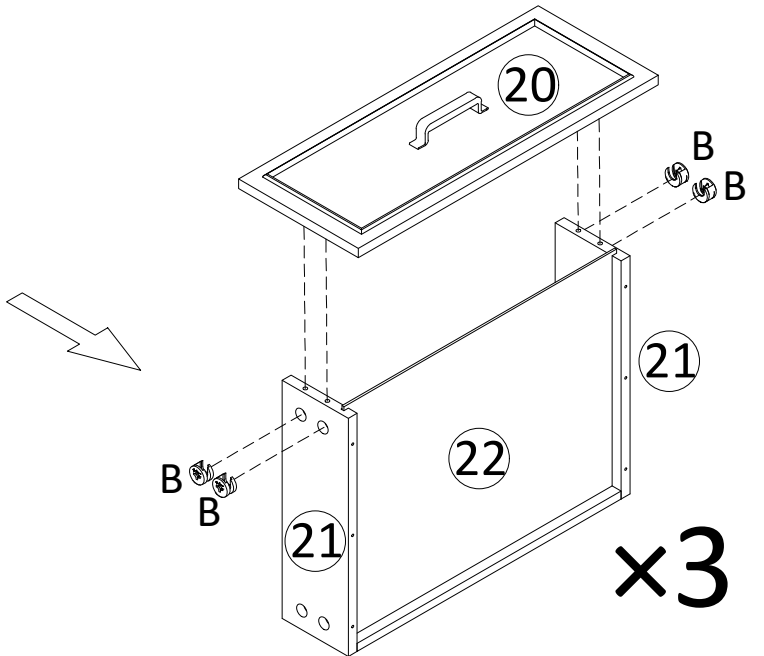
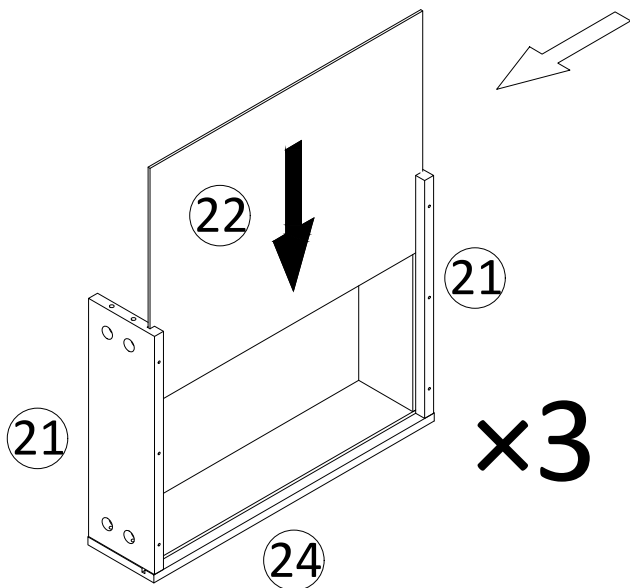
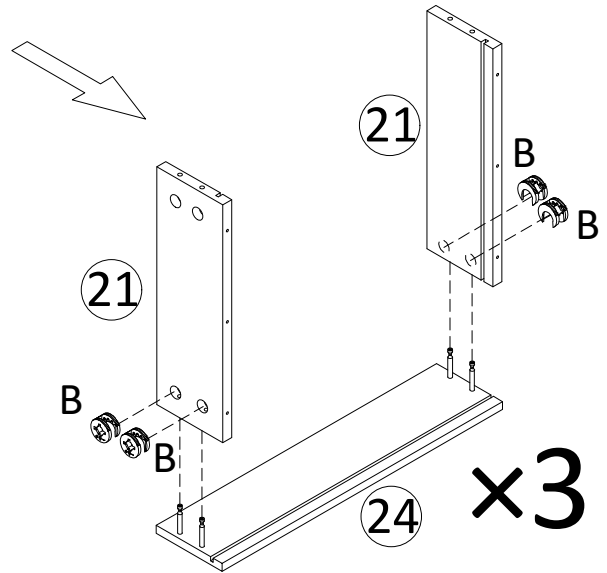
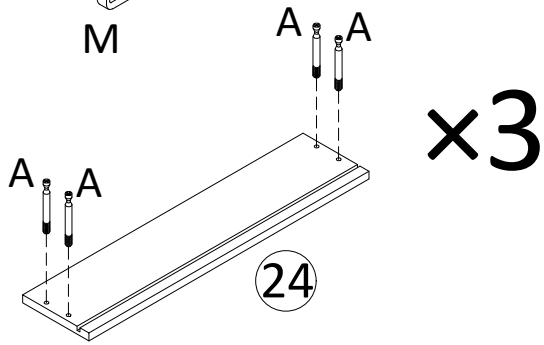
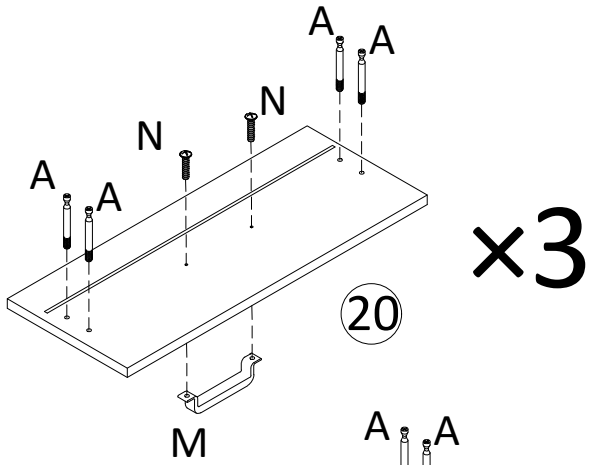

22

Turn the screws vertically from slow to fast.

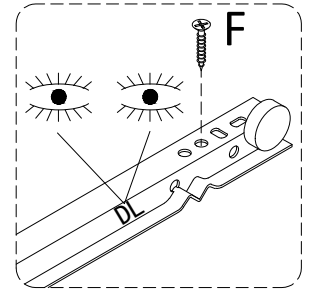
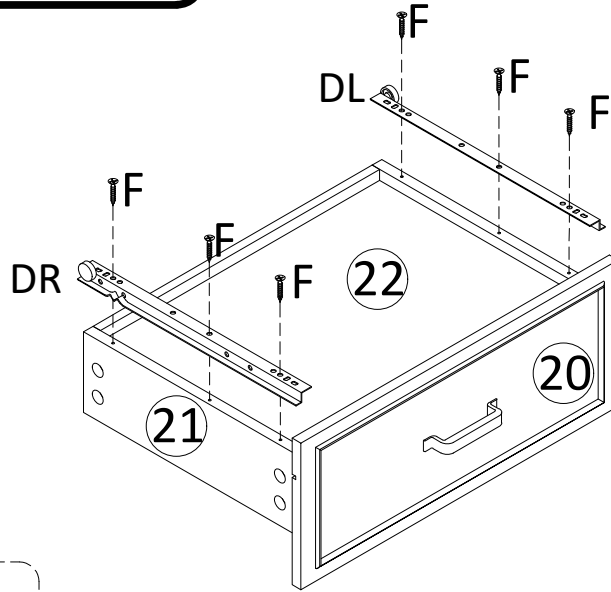

x3

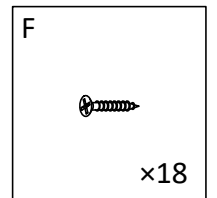
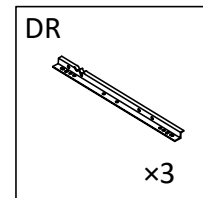
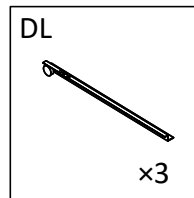
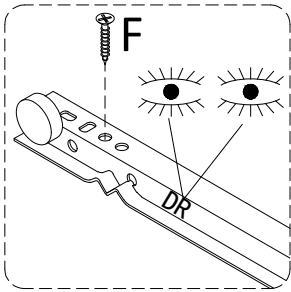

23

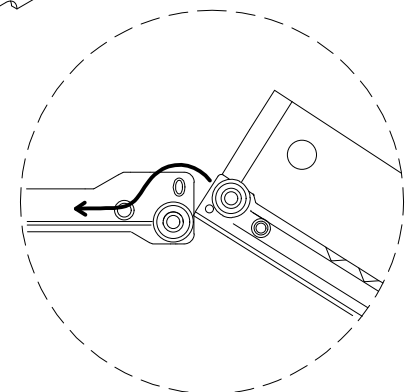
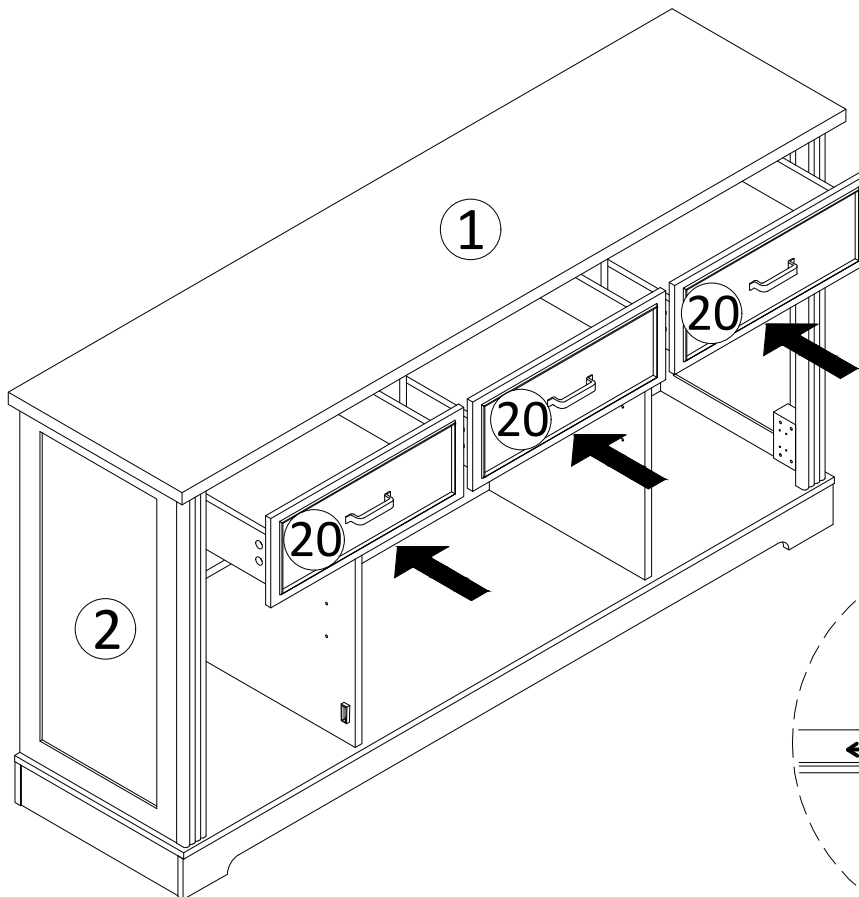

24

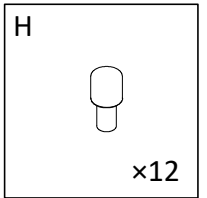
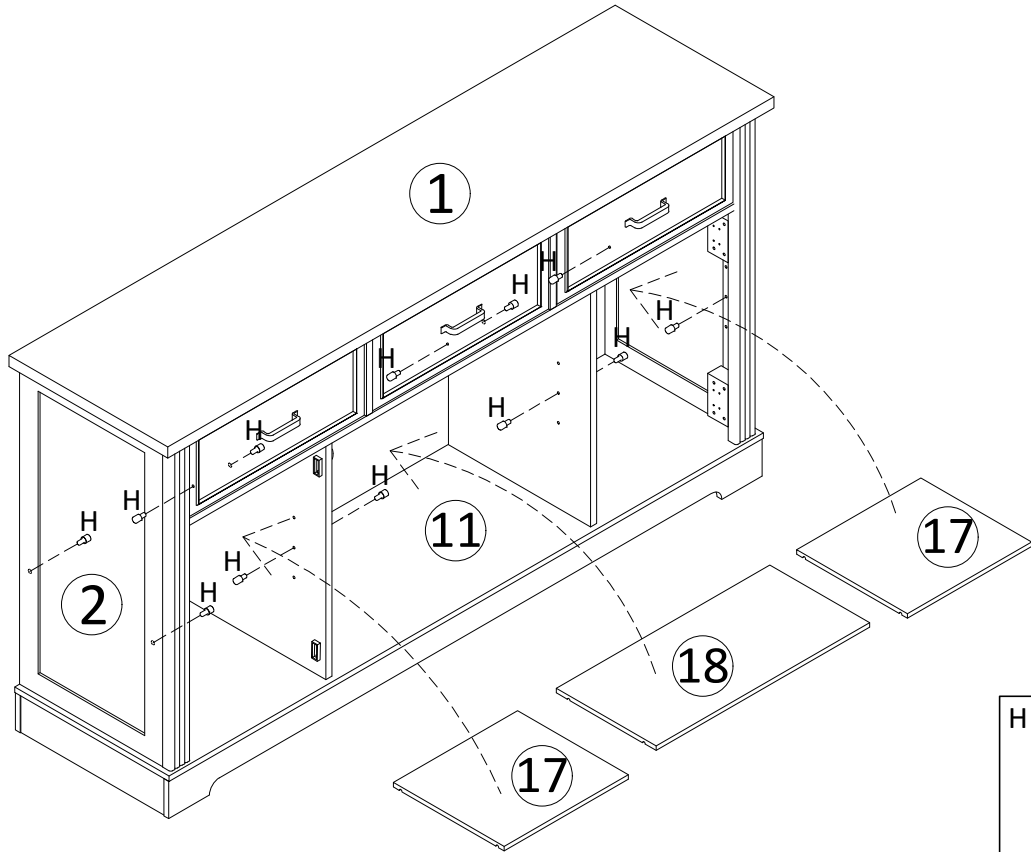

25

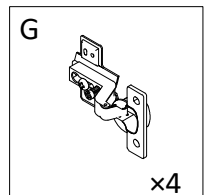
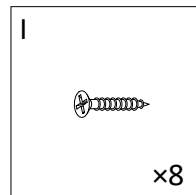
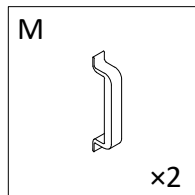
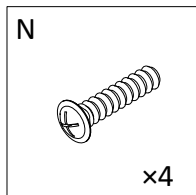
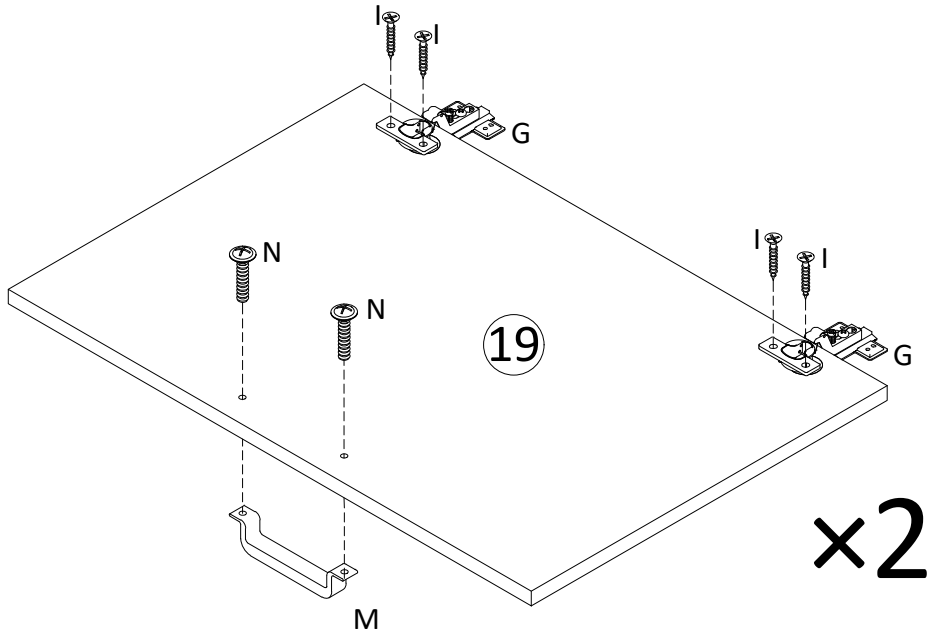

STEP (1)

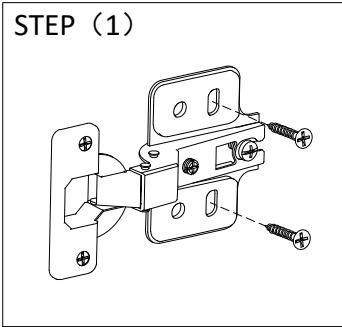

Tips: Turning the screw to approx 50% tightness, don't be fully tight.

STEP (2)

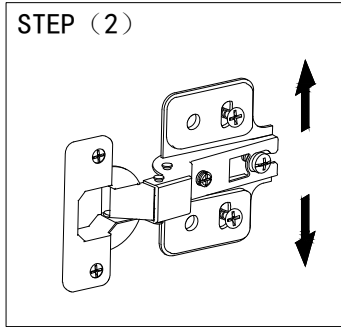

Tips: Moving the hinges up or down appropriately to adjust the gap between the door with the cabinet top and bottom.

STEP (3)

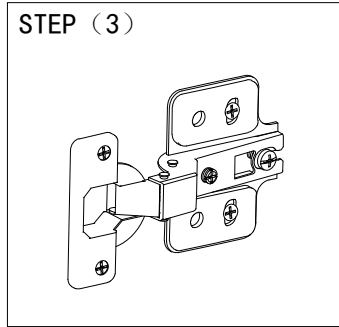

Tips: Tightening the screws completely.

STEP (4)

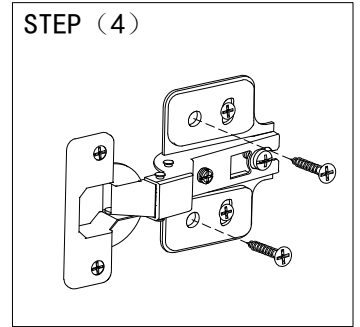

Tips: Tightening the other screws completely.

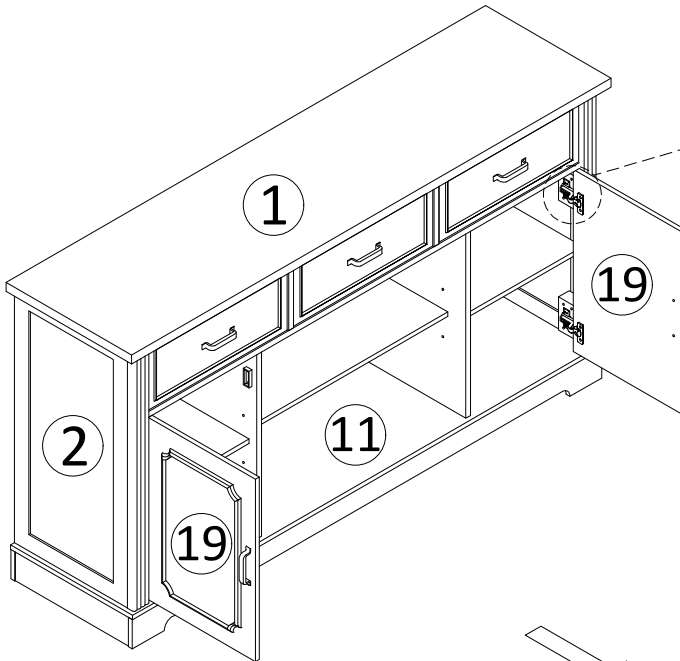

Turn the screws vertically from slow to fast.

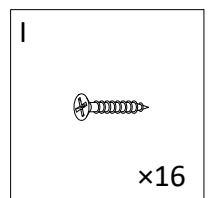
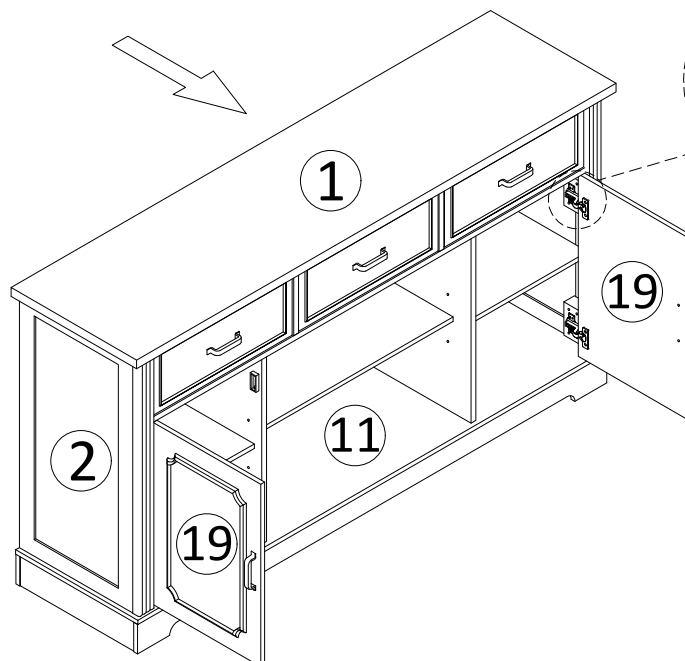

27 Tips: If the gap between the doors with the partition panel is too far or close, please turning the screw as shown below .

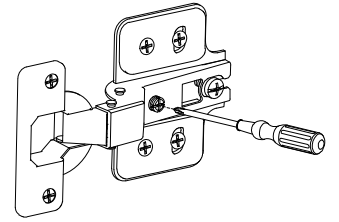
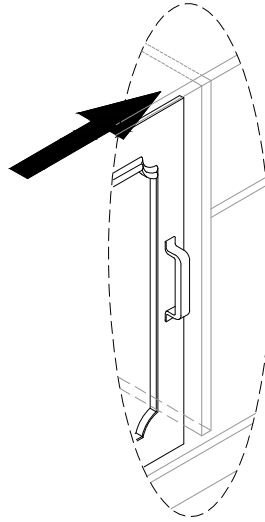
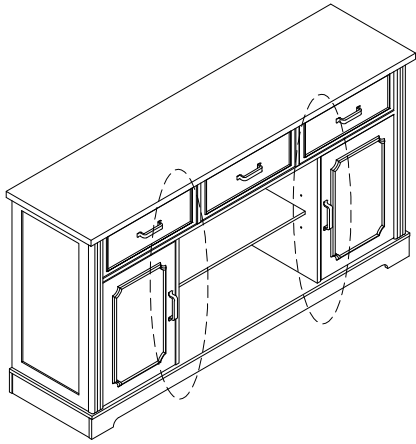

Tips: Adjusting the screw as shown in the following picture can make the door move forward or backward.

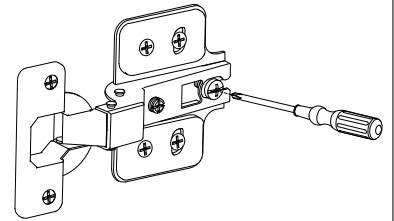
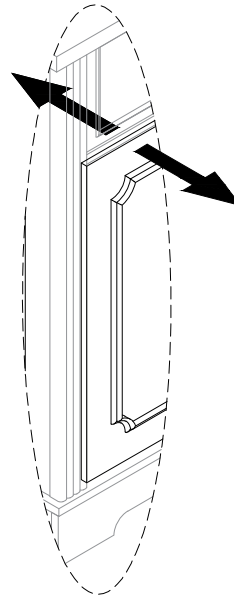
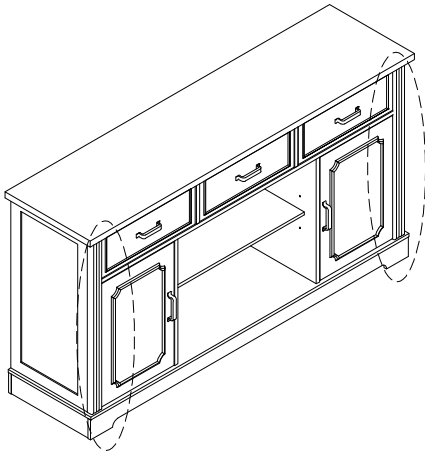

Tips: Adjusting the levelers appropriately underneath the bottom of the foot can make the gaps between the door and frames of cabinet even.

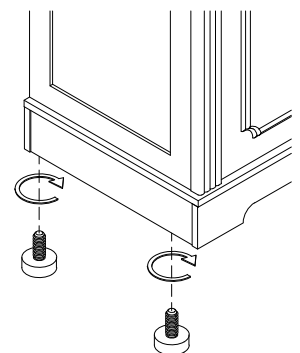
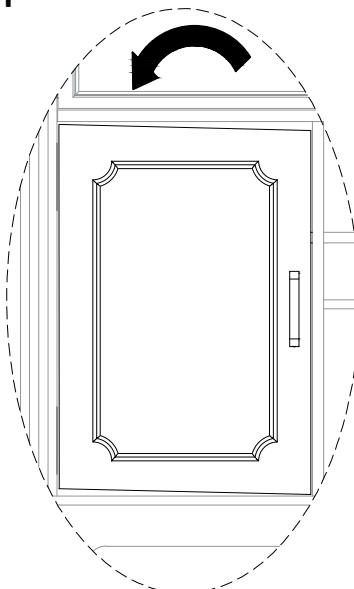
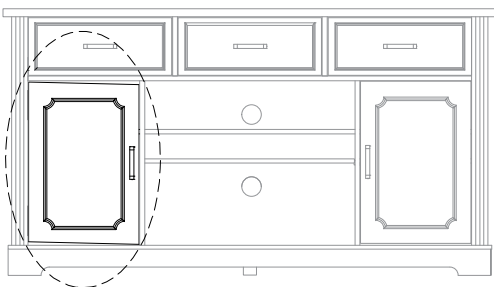

28

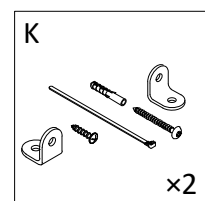
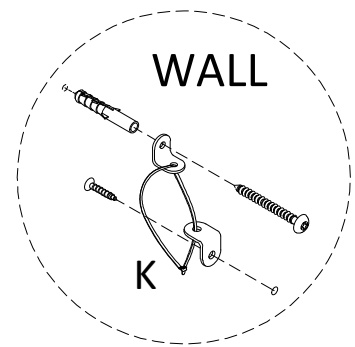
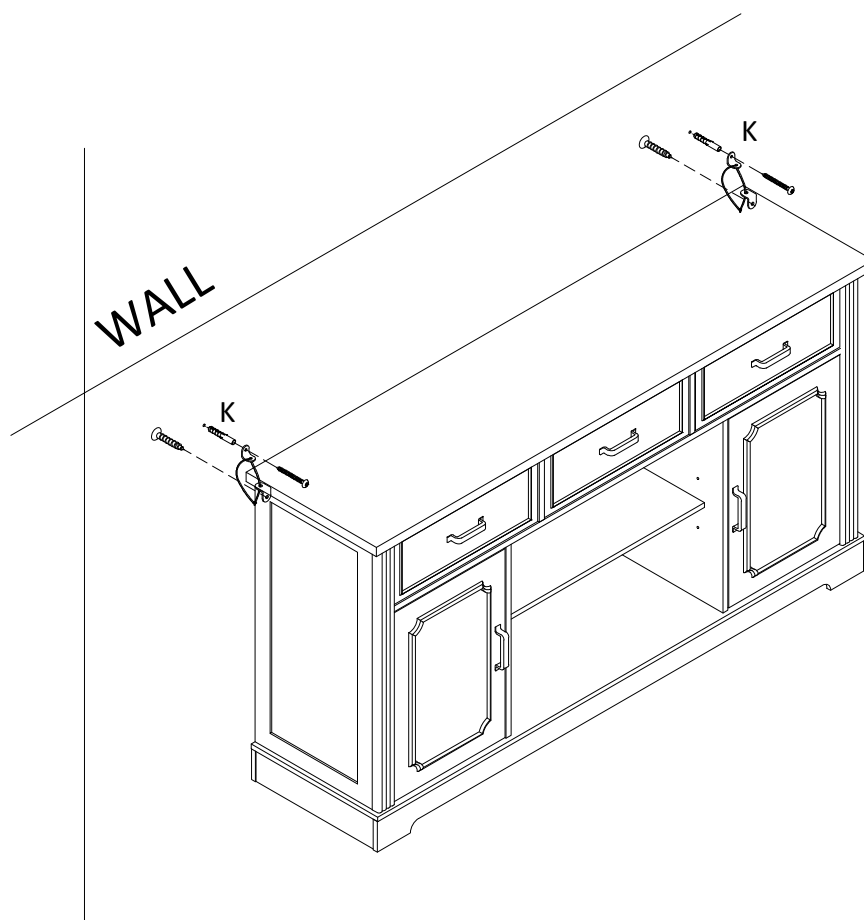

29

