

LJJ-V1

FTBFSR-5006

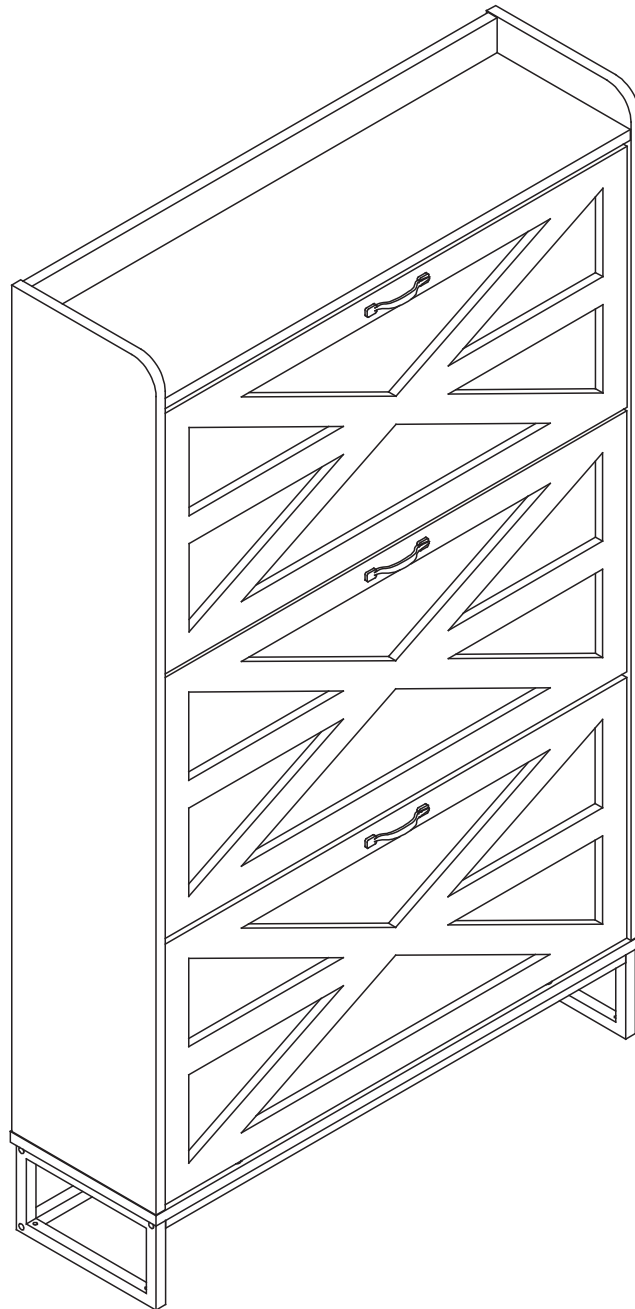

**SHOE CABINET
SCHUHSCHRANK
MEUBLE À CHAUSSURES
MOBILE PORTA SCARPE
ZAPATERO**



"IMPORTANT, RETAIN FOR FUTURE REFERENCE: READ CAREFULLY"

German: WICHTIG, FÜR SPÄTERE NACHSCHLAGE AUFBEWAHREN: SORGFÄLTIG LESEN

Spanish: IMPORTANTE, GUARDAR PARA REFERENCIA FUTURA: LEER ATENTAMENTE

Italian: IMPORTANTE, CONSERVARE PER RIFERIMENTI FUTURI: LEGGERE ATTENTAMENTE

French: IMPORTANT, À CONSERVER POUR RÉFÉRENCE FUTURE : LIRE ATTENTIVEMENT

1. Periodically check that all components are tightly secured.

2. Assemble on a flat, clean, and soft surface.

3. Confirm all parts are present prior to assembly.

4. Prepare electric tools in advance for a quicker installation.

1. Prüfen Sie regelmäßig, ob alle Komponenten fest sitzen.

2. Montieren Sie das Gerät auf einer ebenen, sauberen und weichen Oberfläche.

3. Vergewissern Sie sich vor dem Zusammenbau, dass alle Teile vorhanden sind.

4. Bereiten Sie Elektrowerkzeuge im Voraus vor, um eine schnellere Installation zu ermöglichen.

1. Vérifiez périodiquement que tous les composants sont bien fixés.

2. Assemblez le tout sur une surface plane, propre et douce.

3. Confirmez que toutes les pièces sont présentes avant l'assemblage.

4. Préparez les outils électriques à l'avance pour une installation plus rapide.

1. Controllare periodicamente che tutti i componenti siano fissati saldamente.

2. Assemblare su una superficie piana, pulita e morbida.

3. Assicurarasi che siano presenti tutte le parti prima dell'assemblaggio.

4. Preparare gli strumenti elettrici in anticipo per un'installazione più veloce.







1. Revise que todos los componentes estén asegurados con regularidad.



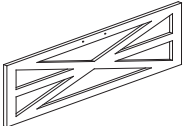
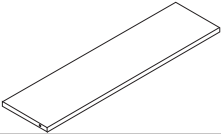

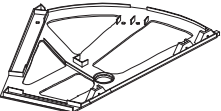

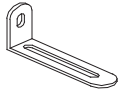
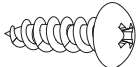
2. Monte sobre una superficie que sea plana, limpia y suave.

3. Antes de montar el producto, revise que tenga todas las piezas a mano.

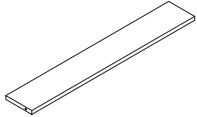
4. Para facilitar la instalación, prepare las herramientas eléctricas necesarias con tiempo.

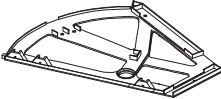
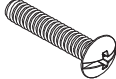
Item no. Nr. N° d'article Articolo No. Artículo No.	Reference Image Referenzbild Image de référence Immagine di riferimento Imagen de referencia	Qty. Menge Qté. Qtà Cant.	Item no. Nr. N° d'article Articolo No. Artículo No.	Reference Image Referenzbild Image de référence Immagine di riferimento Imagen de referencia	Qty. Menge Qté. Qtà Cant.
1		X1	2		X1
3		X1	4		X1
5		X1	6		X2
7		X1	8		X2
9		X2	10		X1

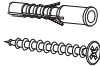
Item no. Nr. N° d'article Articolo No. Artículo No.	Reference Image Referenzbild Image de référence Immagine di riferimento Imagen de referencia	Qty. Menge Qté. Qtà Cant.
11		X3
13		X6
B	 φ15*12mm	X20
D		X3
F		X3
H	 ST3.5*14mm	X10
J		X2
L	 ST4*14mm	X2
N	 M6*25mm	X12
P		X6

Item no. Nr. N° d'article Articolo No. Artículo No.	Reference Image Referenzbild Image de référence Immagine di riferimento Imagen de referencia	Qty. Menge Qté. Qtà Cant.
12		X3
A	 φ6*35mm	X20
C	 φ8*30mm	X14
E		X3
G	 M4*20mm	X6
I	 ST3*16mm	X36
K	 ST4*35mm	X2
M		X2
O		X4

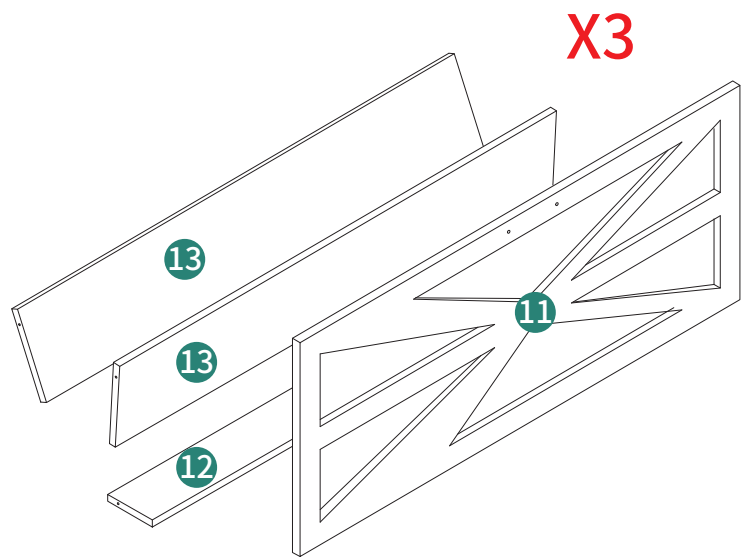
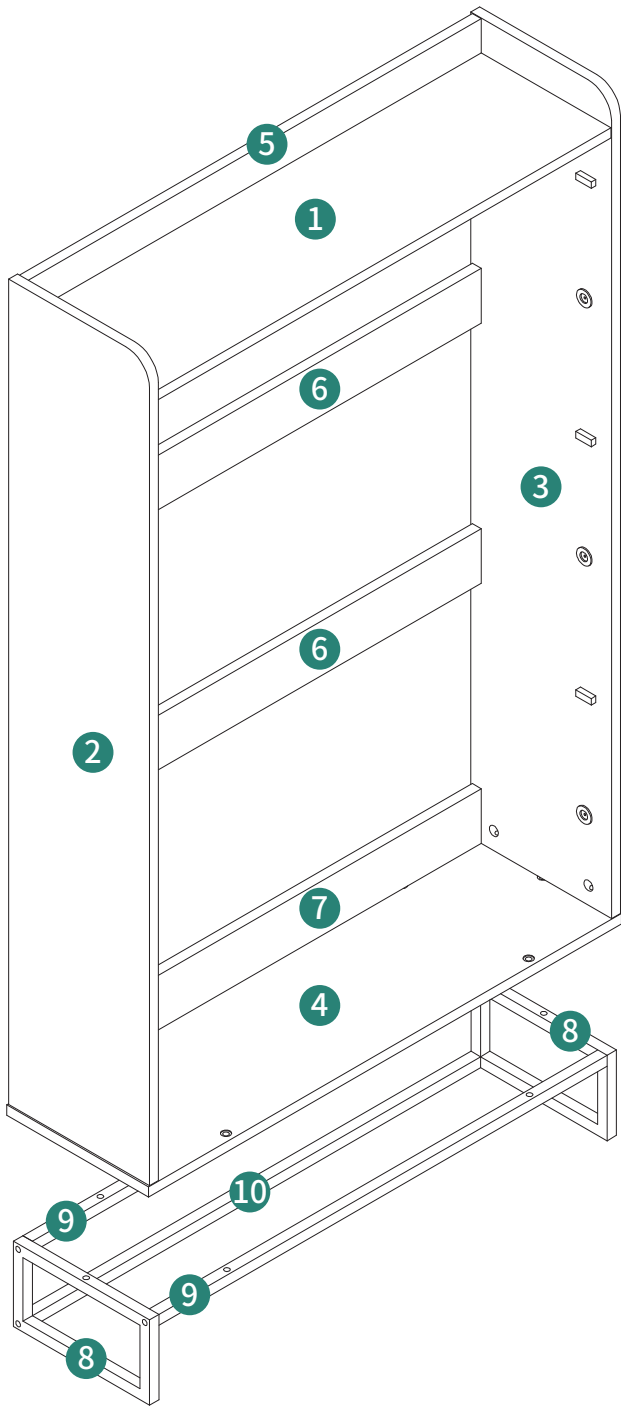

1

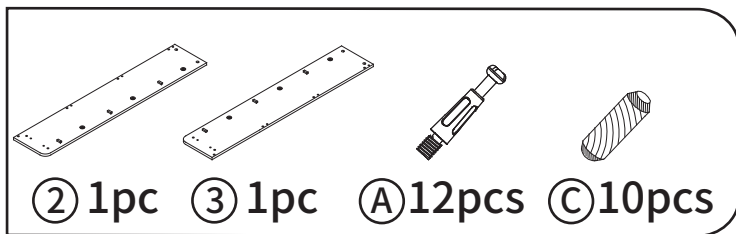

② 1pc ③ 1pc ① 12pcs ④ 10pcs

This block contains a parts list for step 1. It includes two long metal plates (labeled 2 and 3), a screwdriver (labeled A), and a cylindrical pin (labeled C). The items are arranged horizontally. Below the items, the list specifies: ② 1pc, ③ 1pc, ① 12pcs, and ④ 10pcs.

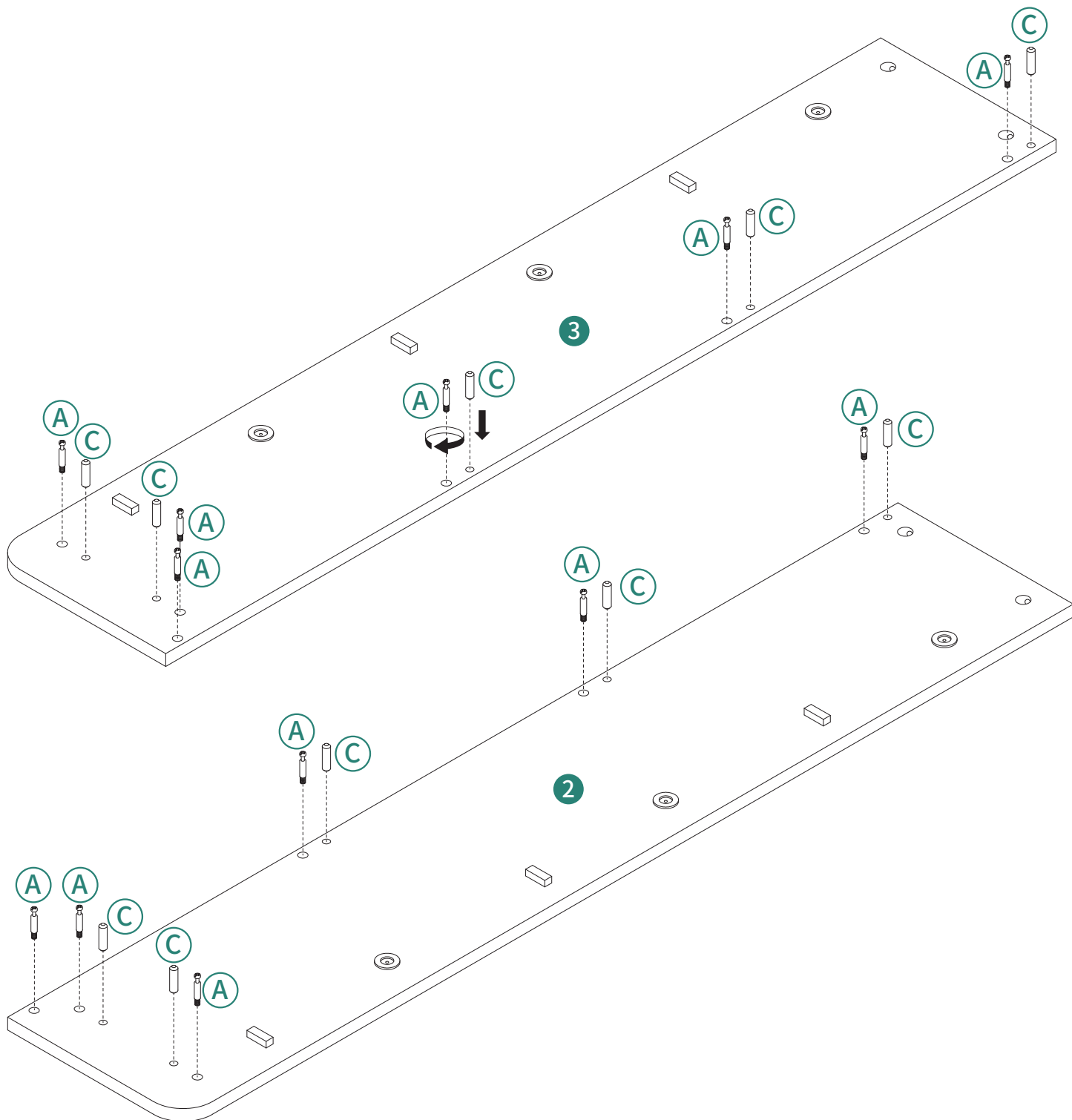
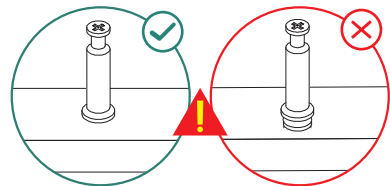

2

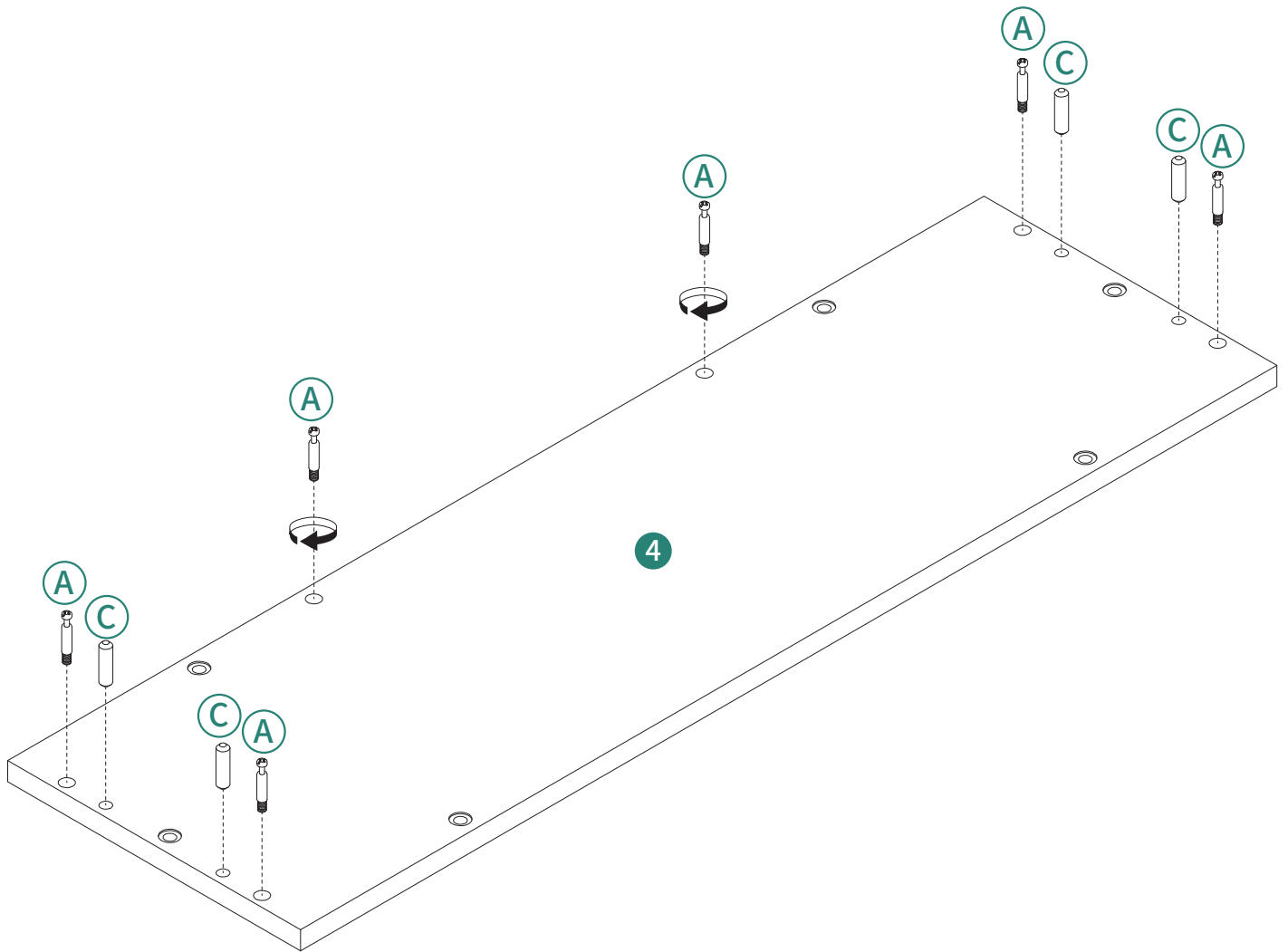
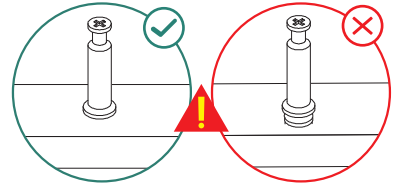
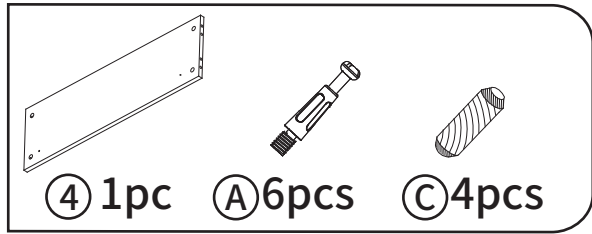

3

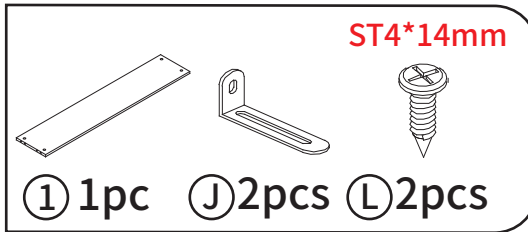

Do not fully tighten screws before completing step 10.

Vor Abschluss von Schritt 10 die Schrauben nicht vollständig festziehen.

Ne serrez pas complètement les vis avant d'avoir terminé l'étape 10.

Non stringere completamente le viti prima di completare il passaggio 10.

No apriete completamente los tornillos antes de completar el paso 10.

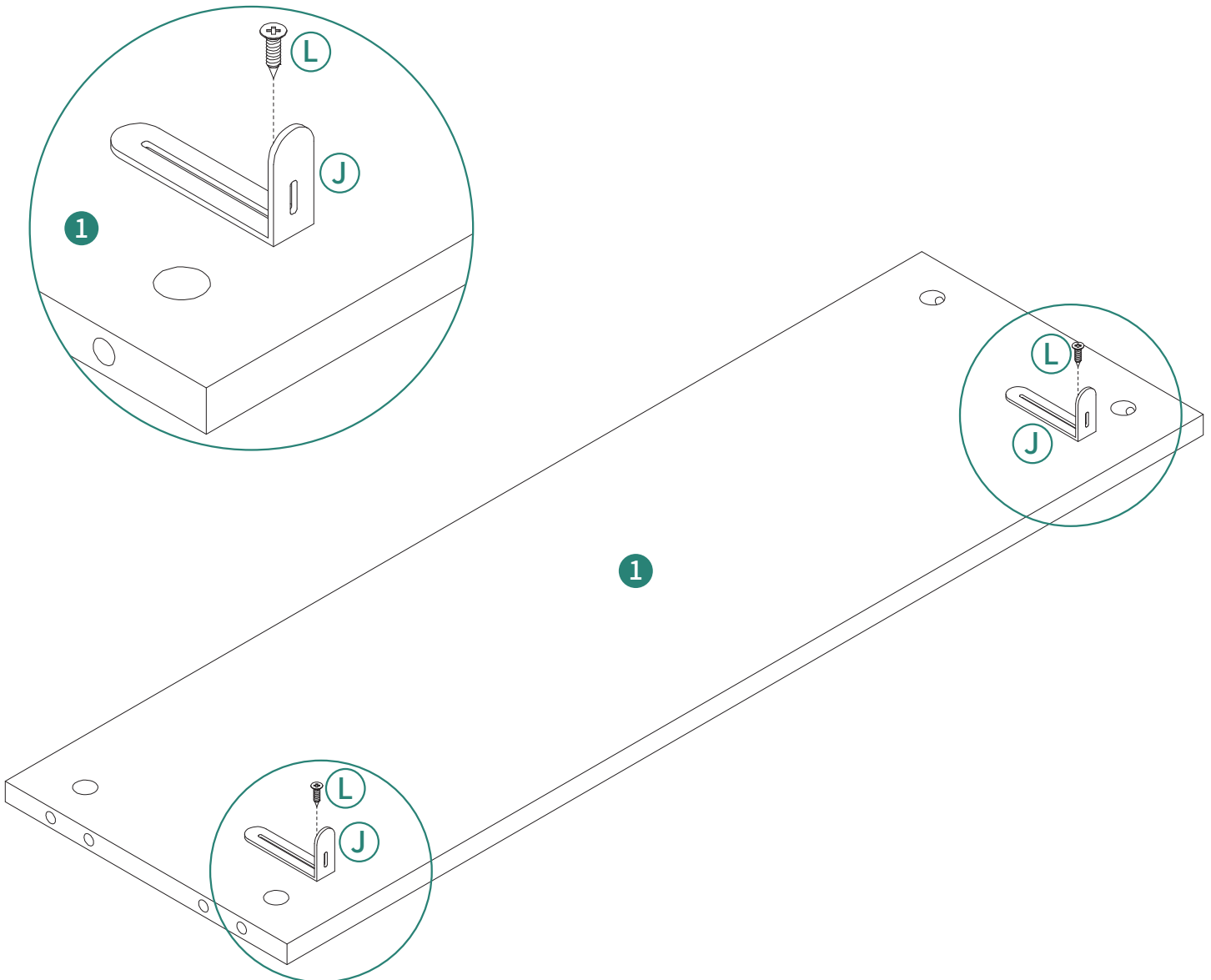

4

- ⑤ 1pc
- Ⓐ 2pcs
- Ⓑ 2pcs

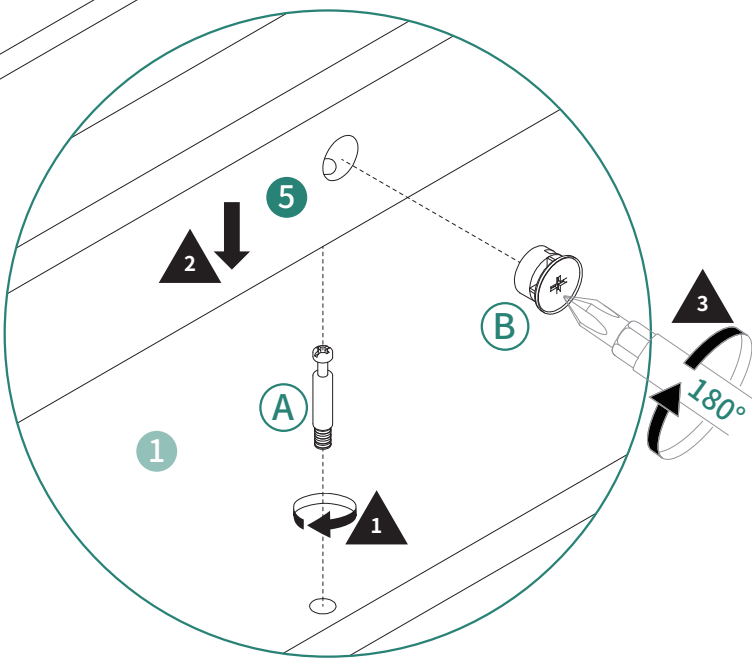
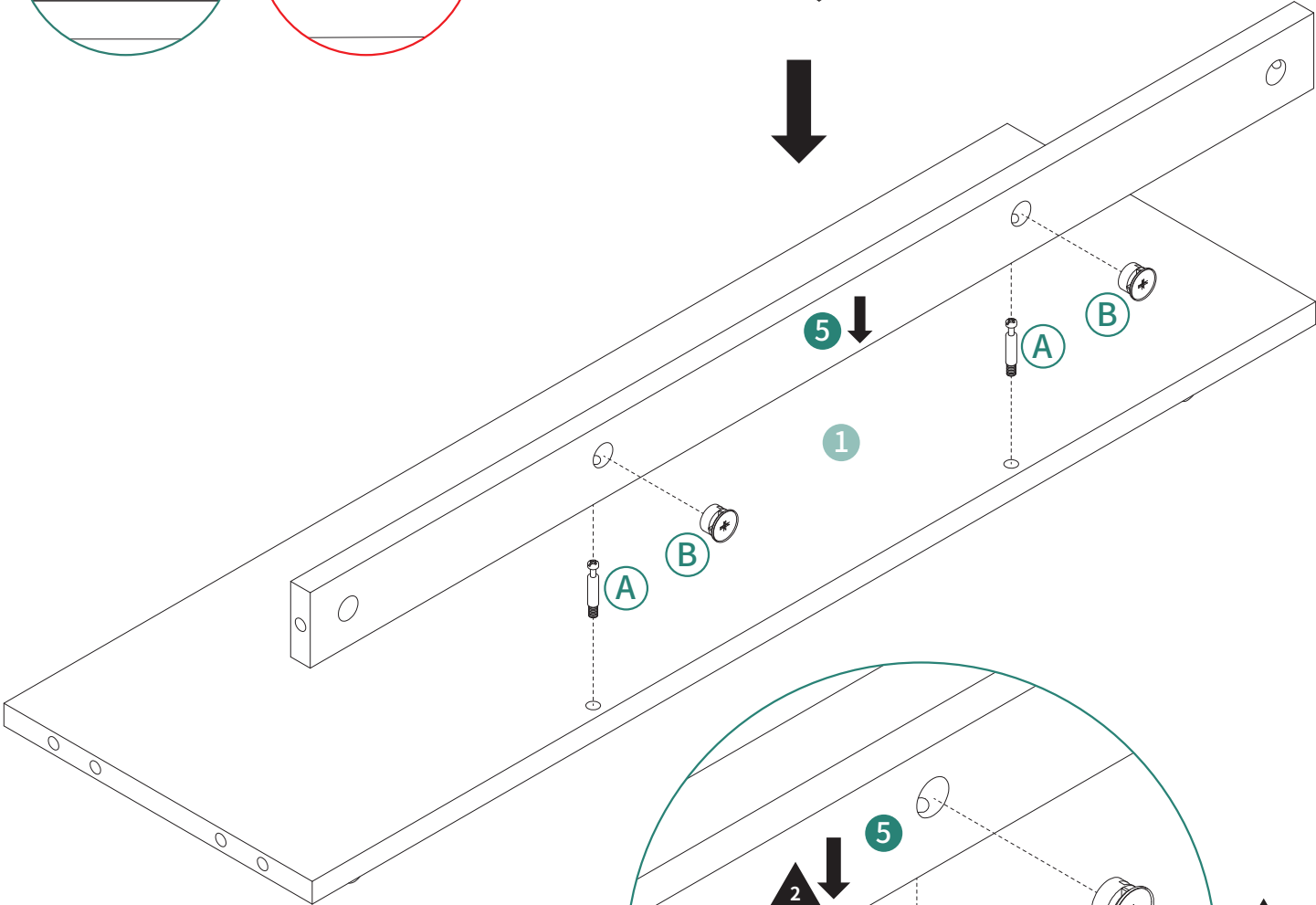
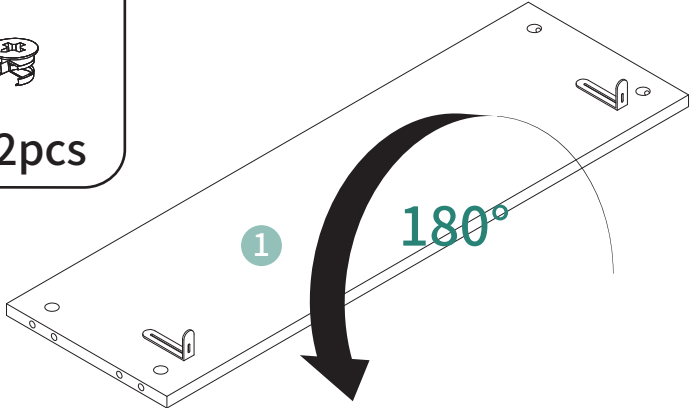
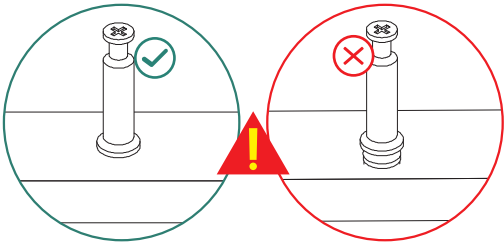

5

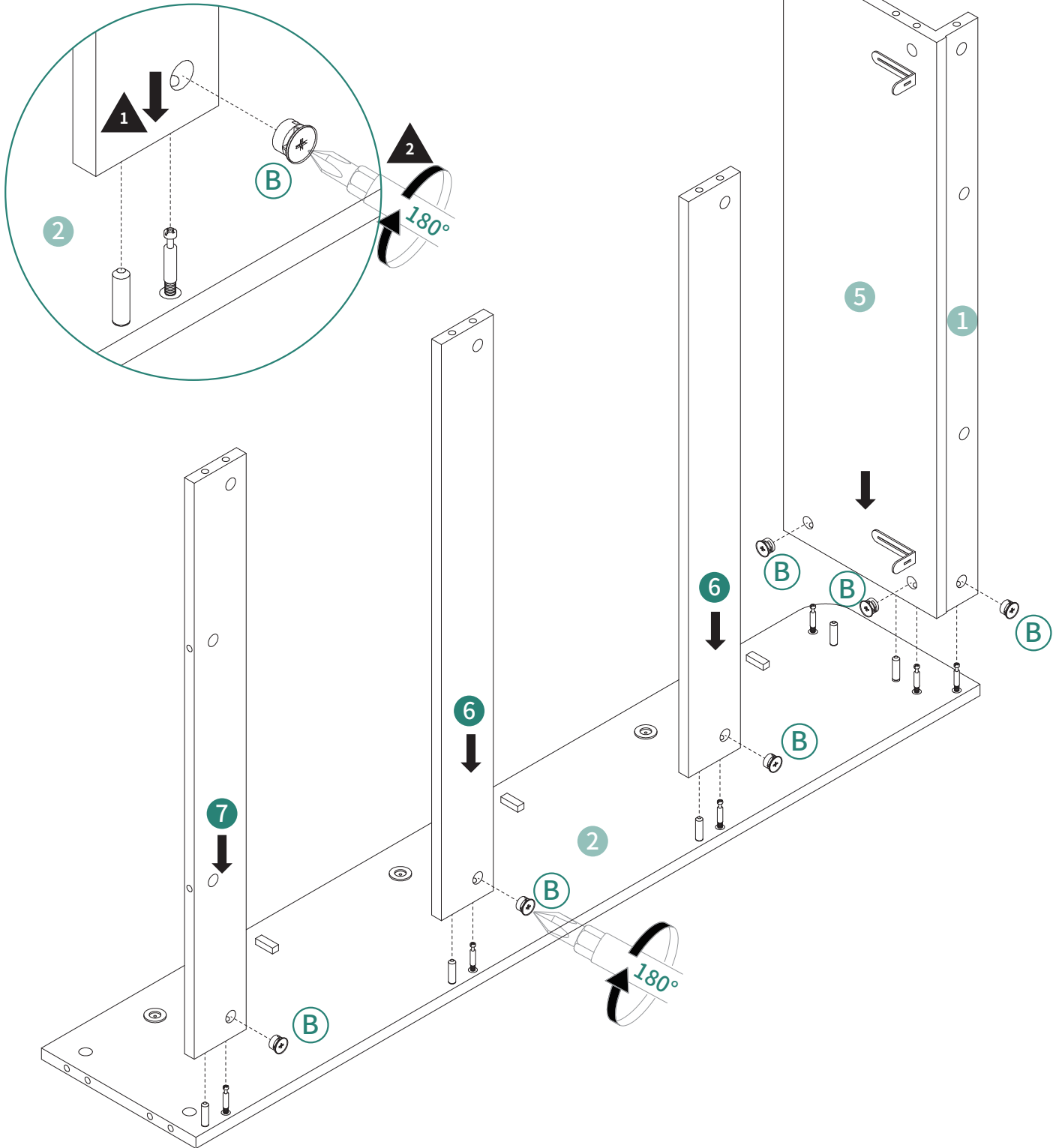
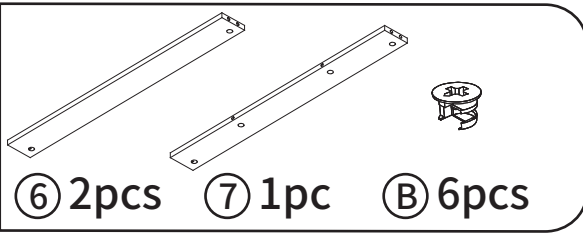

6



(B) 6pcs

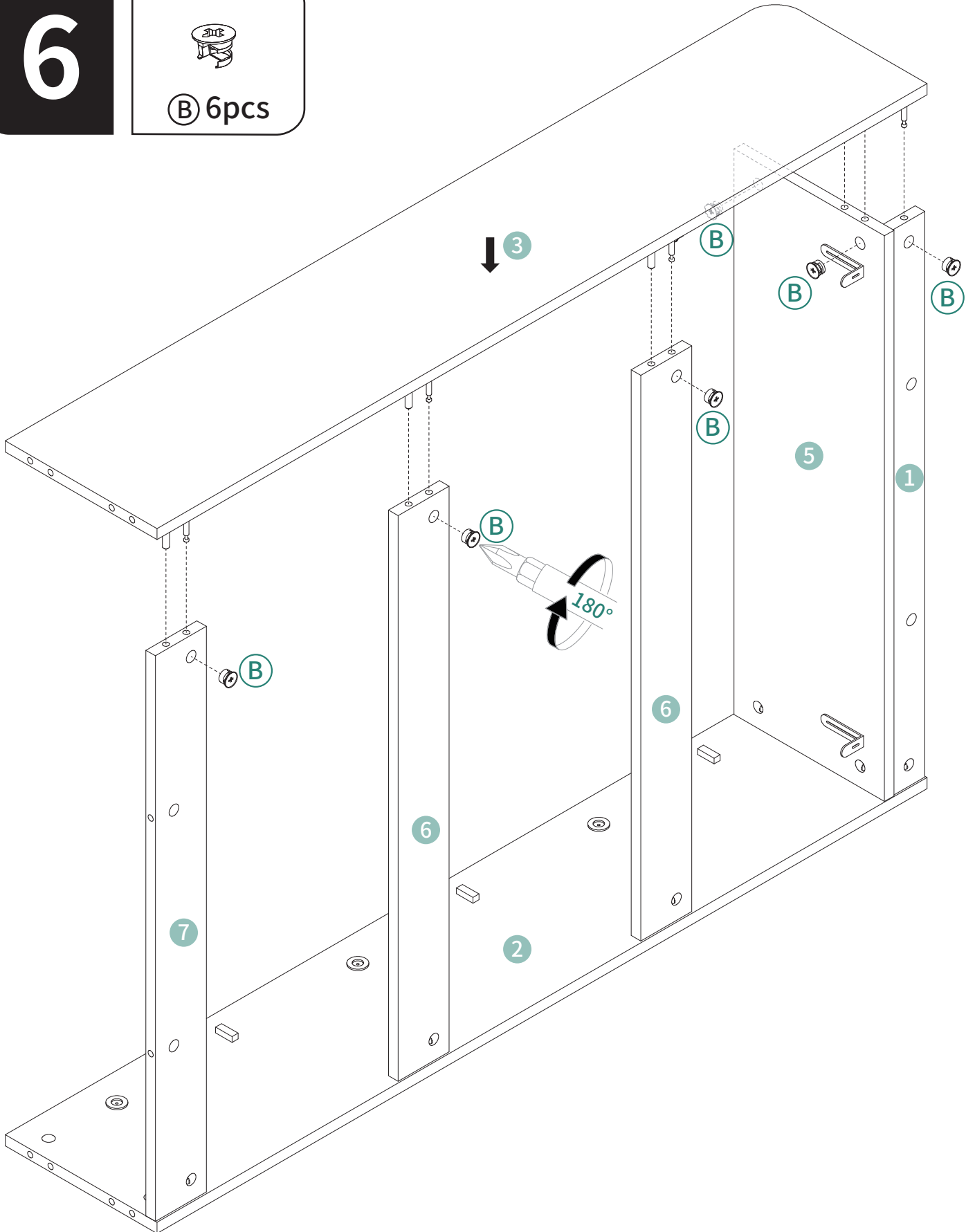

7

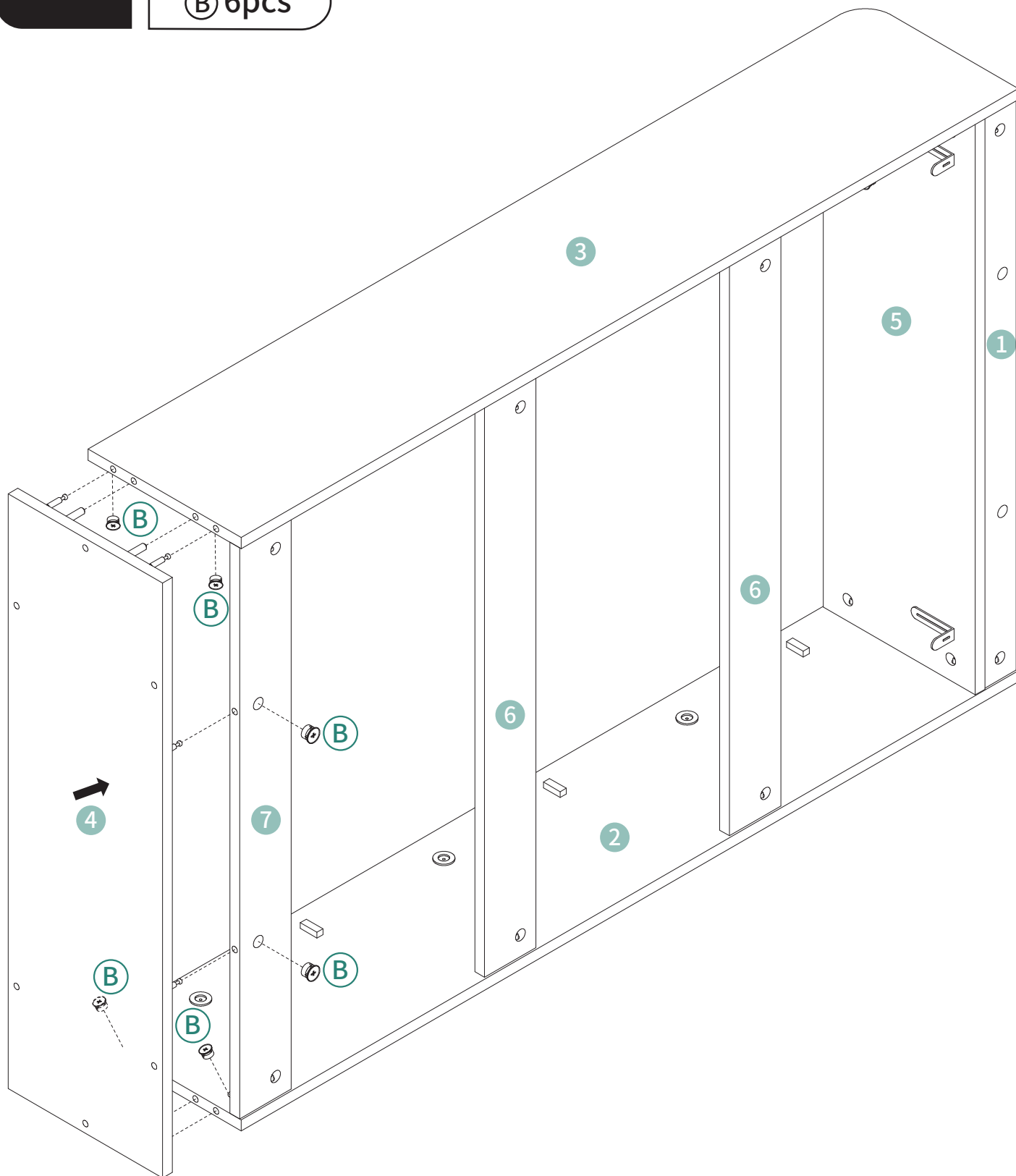
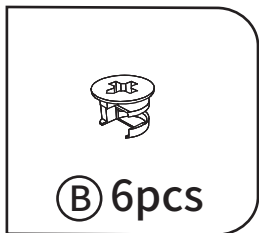

8

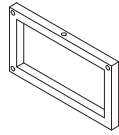

⑧ 2pcs

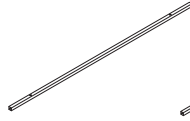

⑨ 2pcs

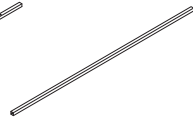

⑩ 1pc

M6*25mm

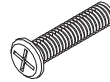

Ⓝ 6pcs



⓪ 4pcs

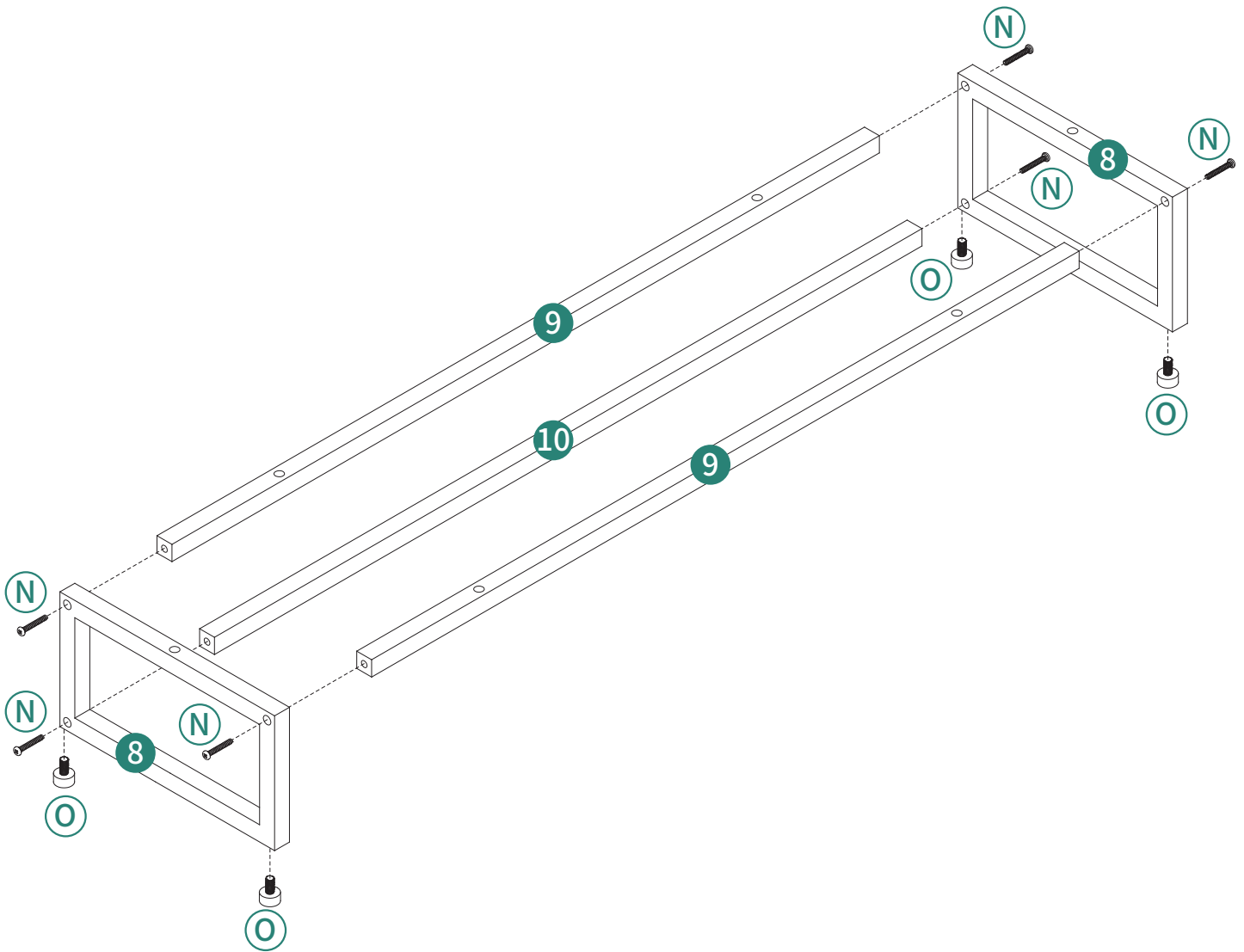

9

M6*25mm



(N) 6pcs

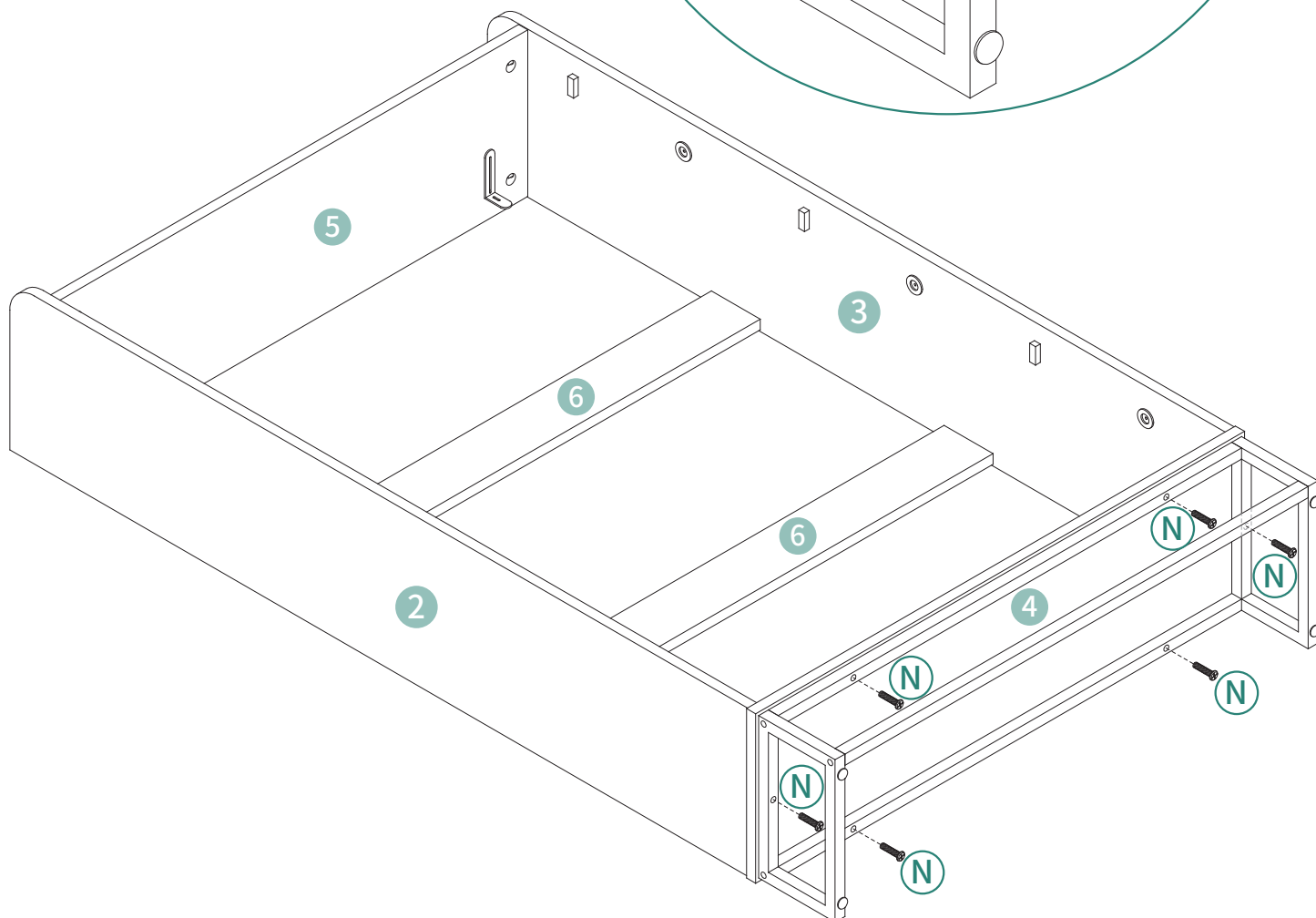
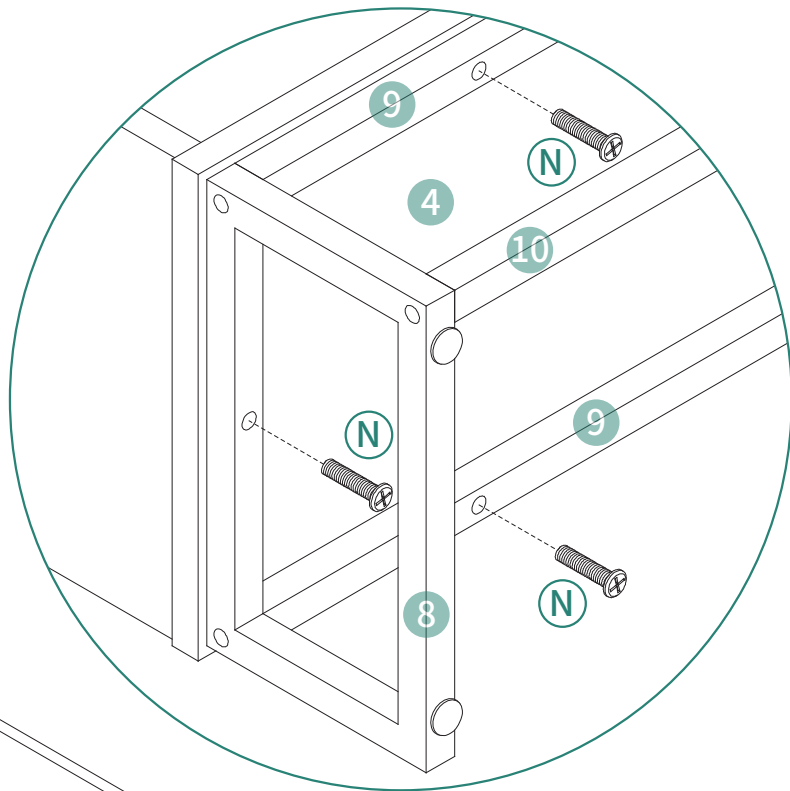

10

ST4*35mm

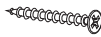

(K) 2pcs

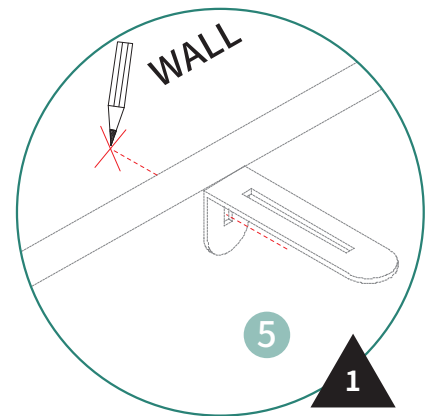
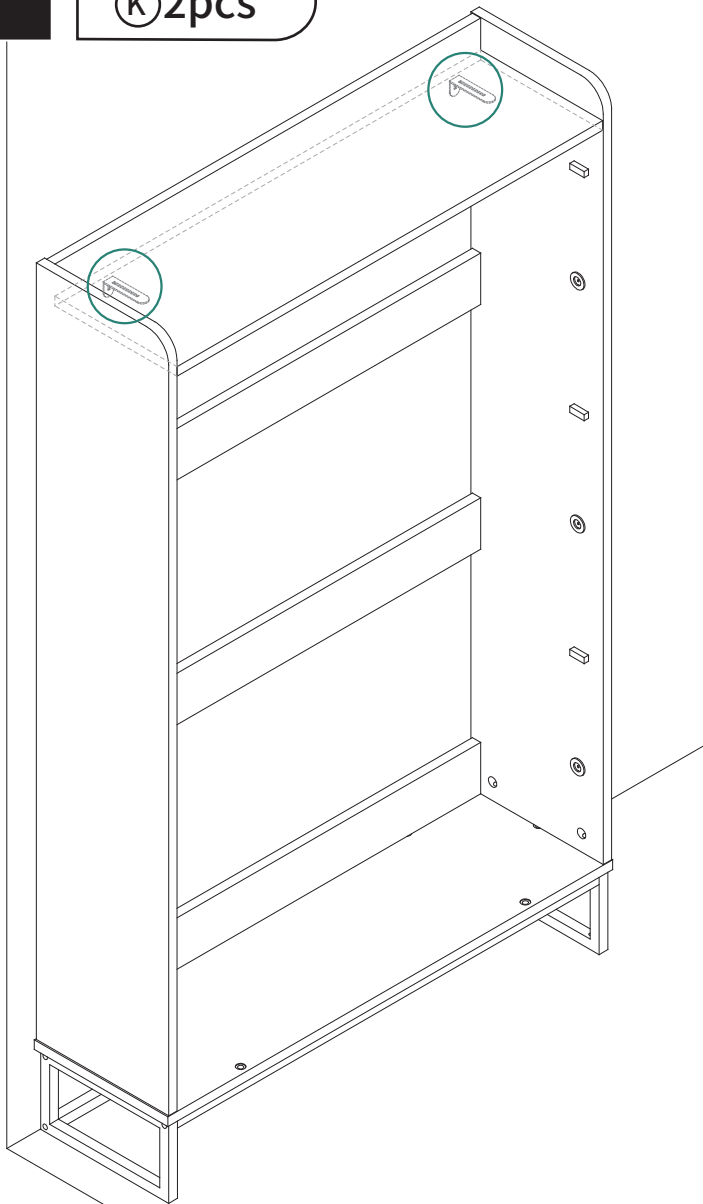

1

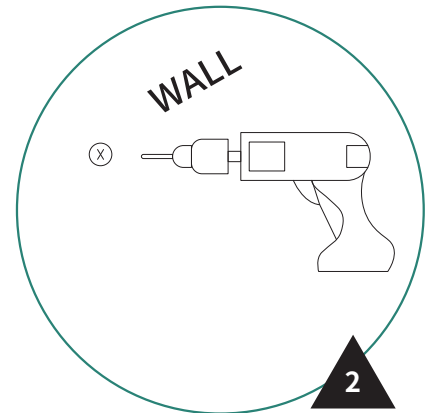

2

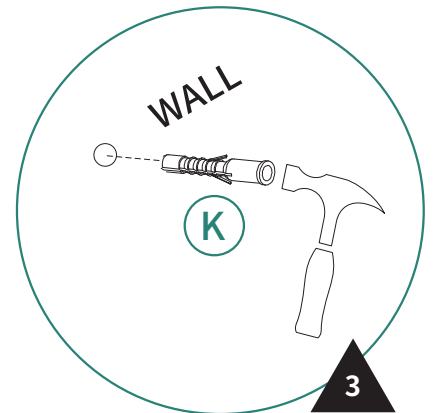

3

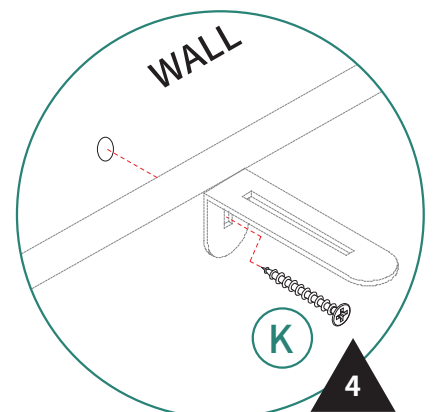

4

Fixing the fabric dresser to the wall is recommended.
Please follow the instructions.

Es wird empfohlen, die Stoffkommode an der Wand zu befestigen.
Bitte befolgen Sie die Anweisungen.

Il est recommandé de fixer la commode en tissu au mur.
Veuillez suivre les instructions.

Si consiglia di fissare il comò in tessuto alla parete. Seguire le istruzioni.

Se recomienda fijar la cómoda de tela a la pared.
Por favor, siga las instrucciones.

11

X3

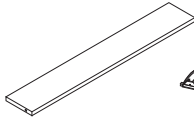

⑫ 3pcs

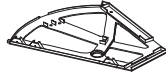

Ⓔ 3pcs

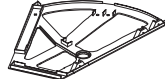

Ⓕ 3pcs



ST3*16mm

Ⓖ 6pcs

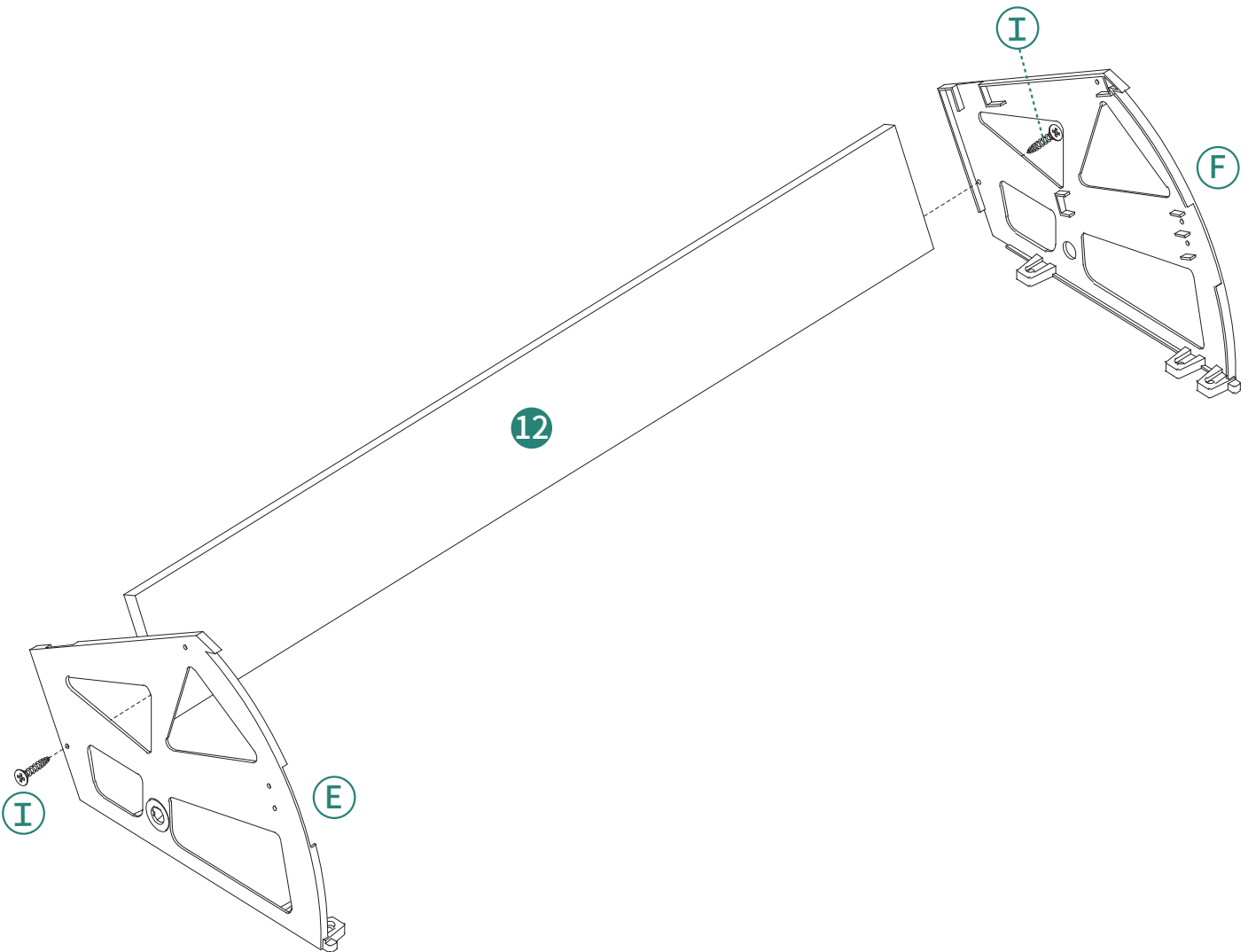

12
X3

M4*20mm ST3*16mm

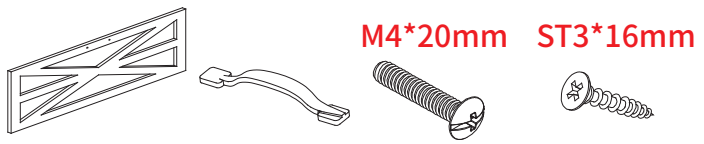

① 3pcs ④ 3pcs ⑥ 6pcs ⑧ 18pcs

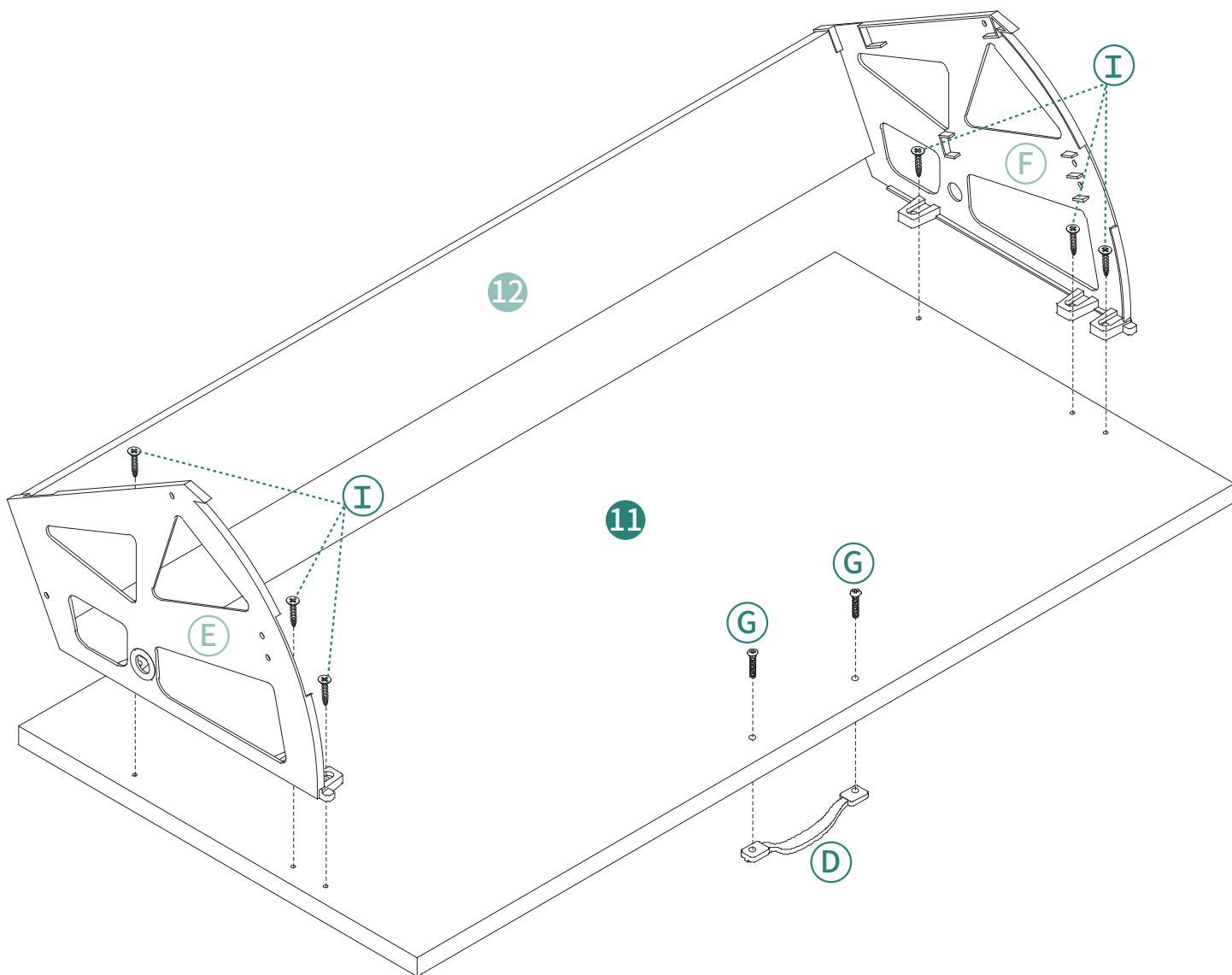

13
X3

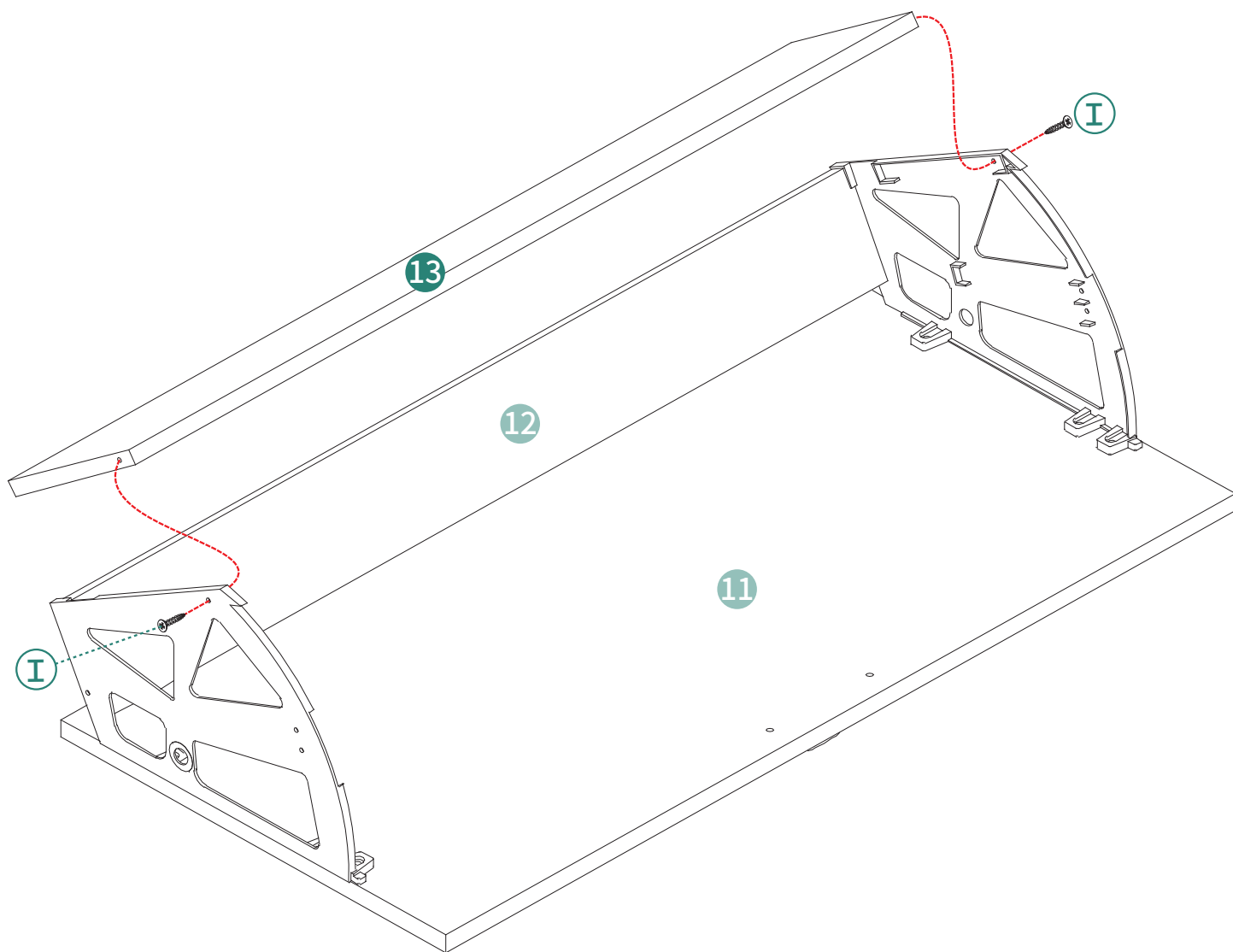
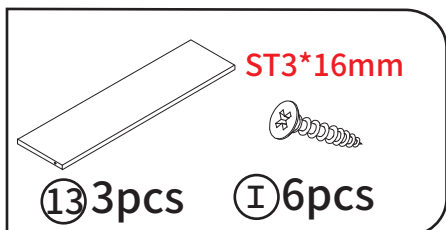

14

ST3.5*14mm

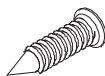

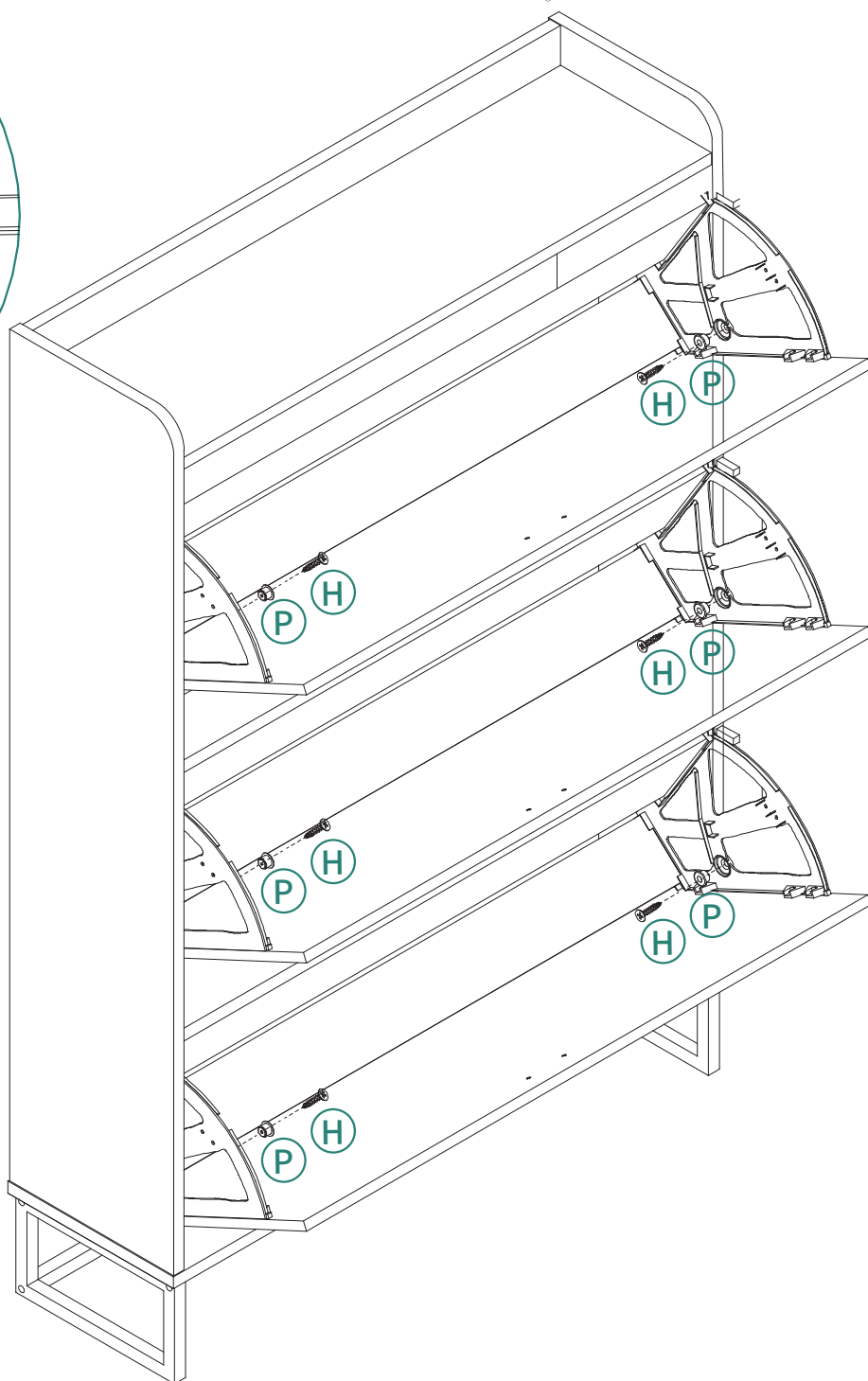
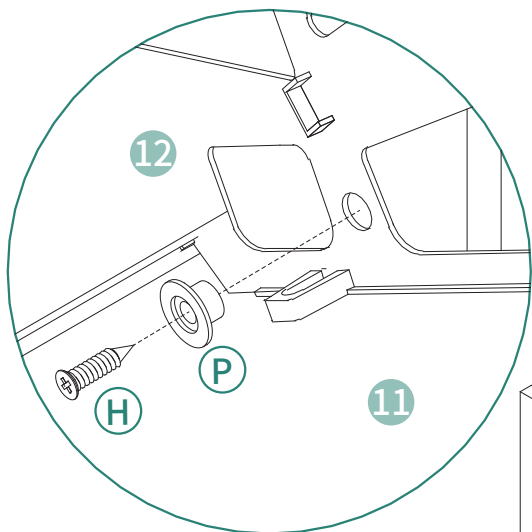
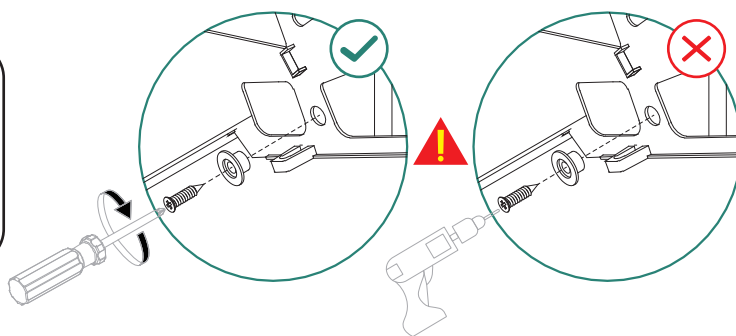

(H) 6pcs

(P) 6pcs

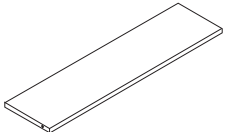

15

 **ST3*16mm**

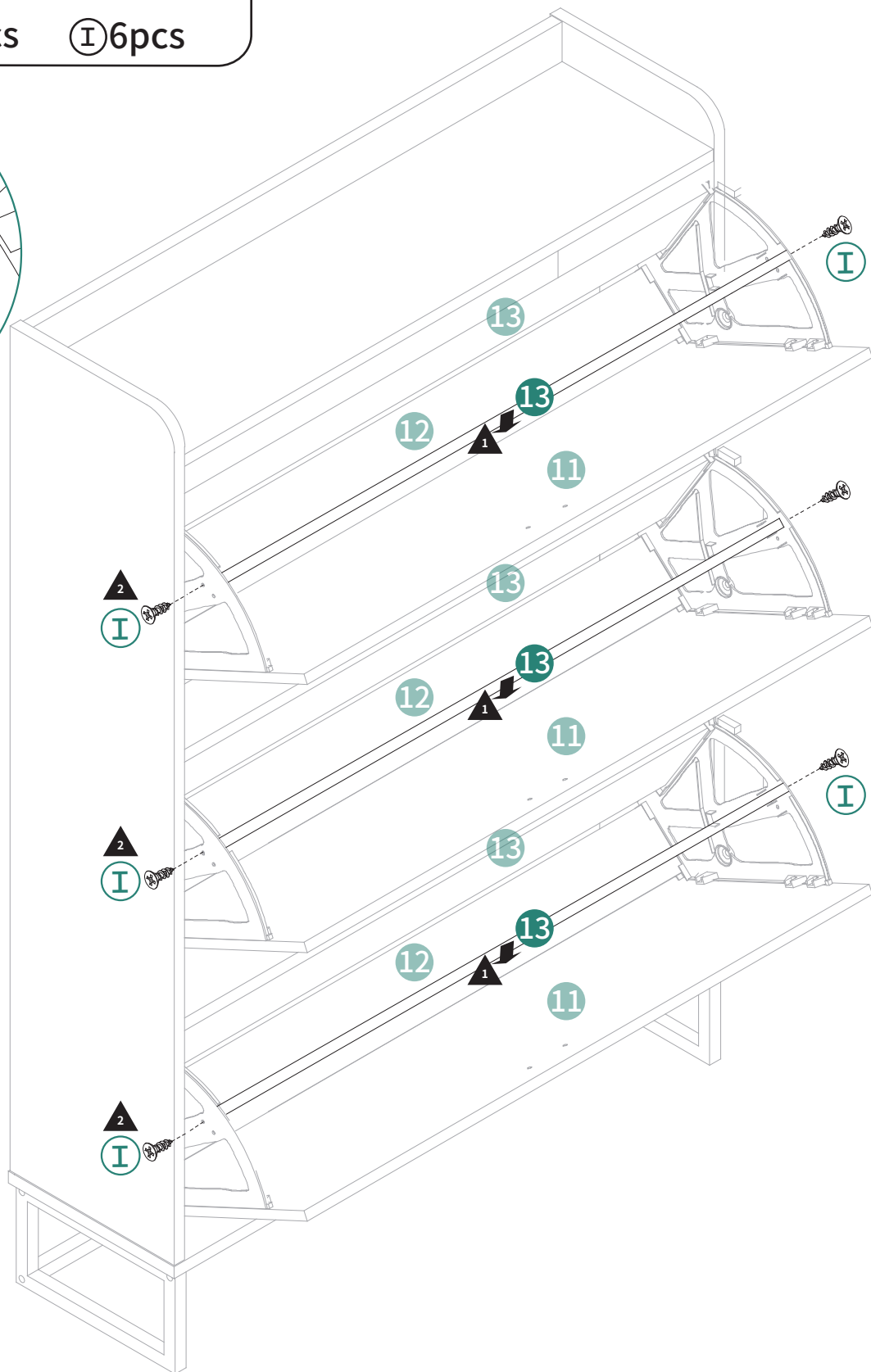
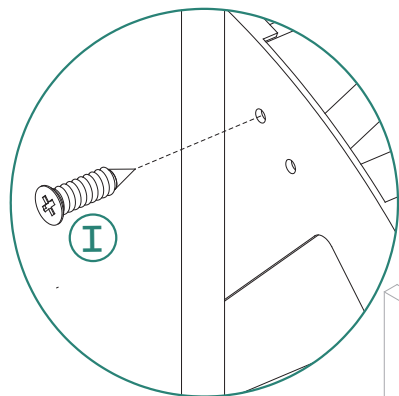
⑬ 3pcs **Ⓘ 6pcs**

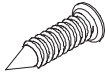

16

ST3.5*14mm



(H) 4pcs



(M) 2pcs

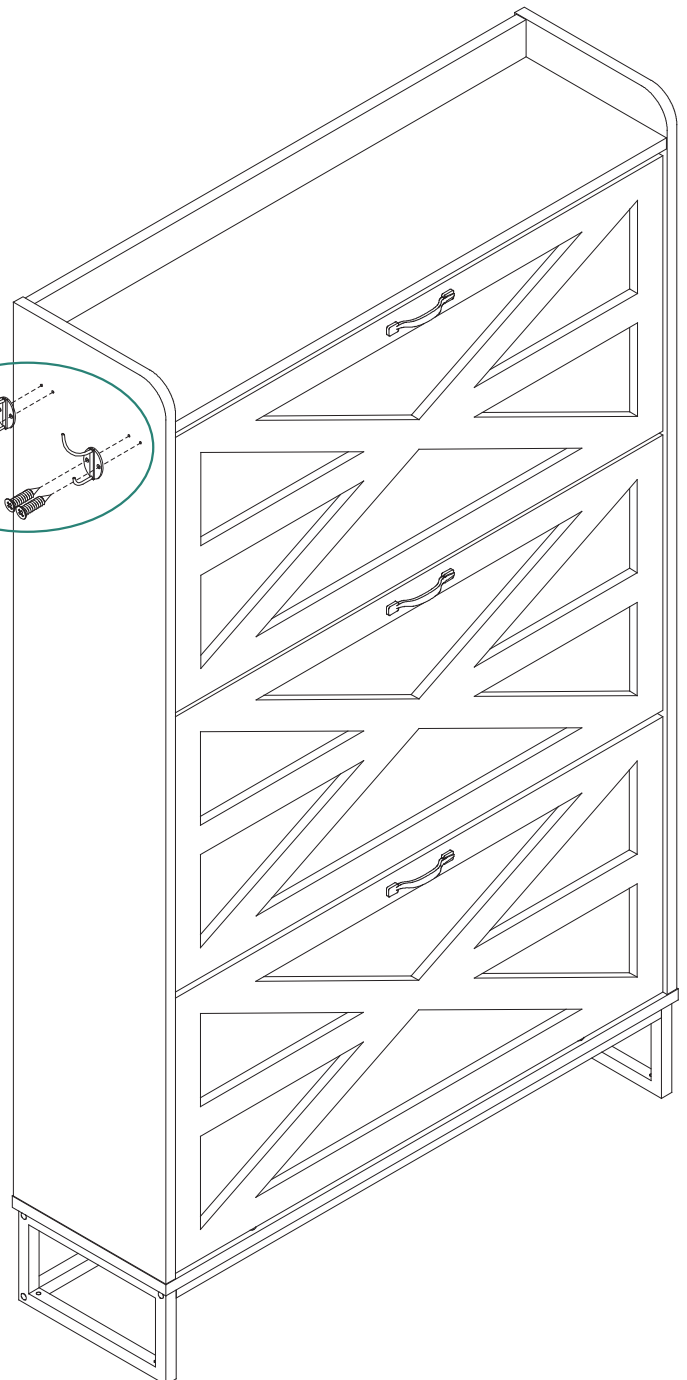
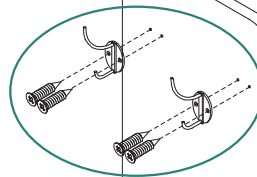
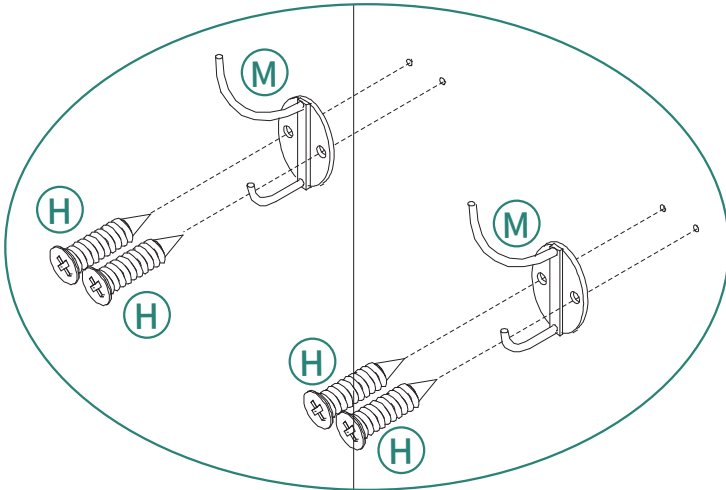

Installation Completed

Installation abgeschlossen

Installation complétée

Installazione completata

Instalación completada