

# Assembly Instructions

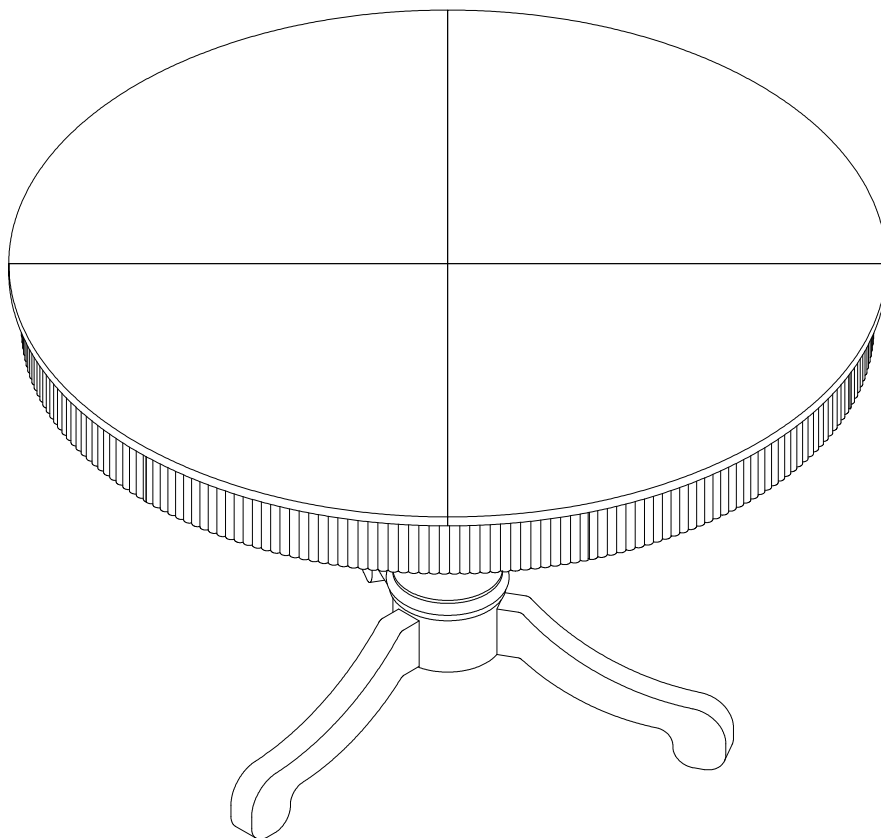

# Before Assembly

## Tips Before Your Start:

- Remove all wrapping material, including staples & packing straps before you start to assemble.
- DO NOT tighten all screws and bolts until the assembly is completely assembled.
- Keep all hardware parts out of reach of children.

## QUICKFIT

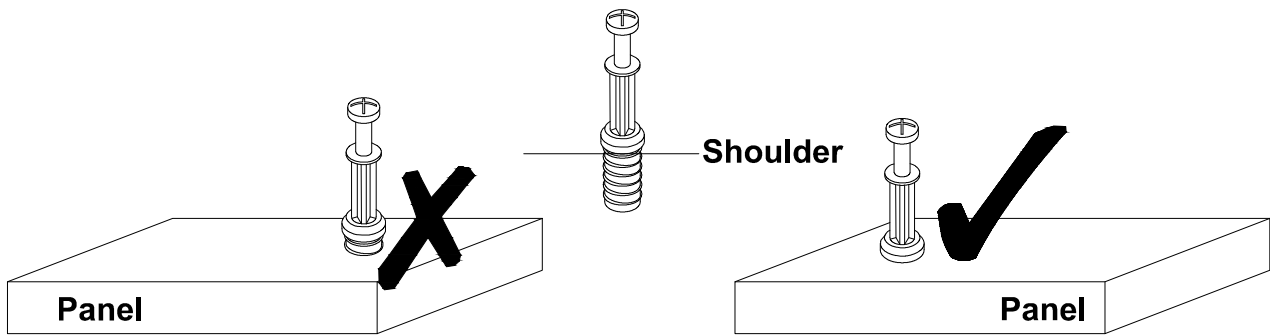

Tighten quickfit until shoulder is flush with panel. Do not overtighten or undertighten.

## CAM LOCK

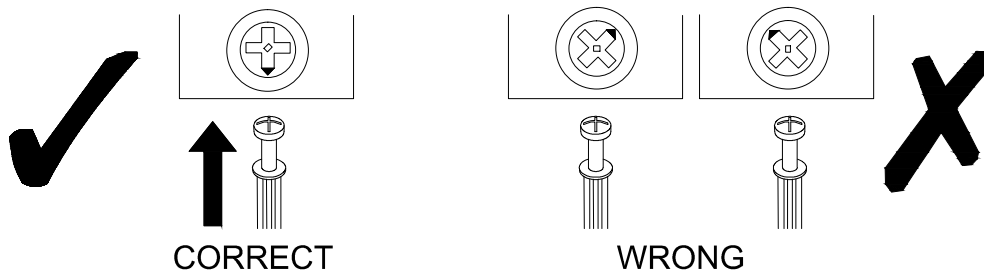

When fitting a cam lock, ensure the starting position is correct before inserting the connecting QUI CKFIT

Quickfit head should be in the centre of the cam lock when the two panels are joined.

Cam lock should be inserted before quickfit.

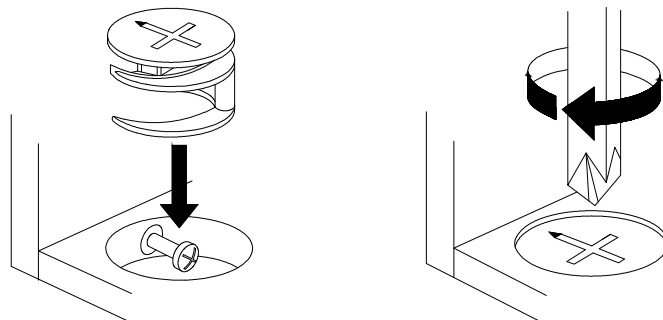

Turn cam lock clockwise to tighten.

# Before Assembly

## Tips Before Your Start

How to separate the drawer slider:

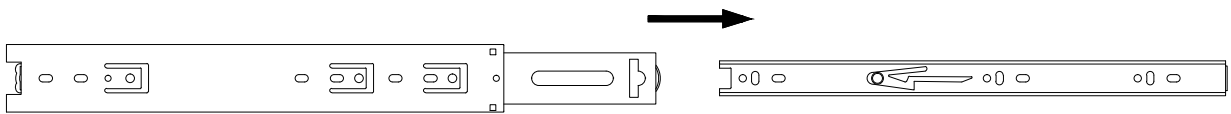
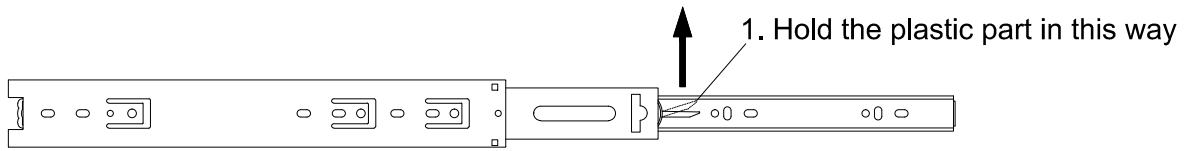

2. Pull out the inner slider for drawer box fixing

## Drawer Front Alignment

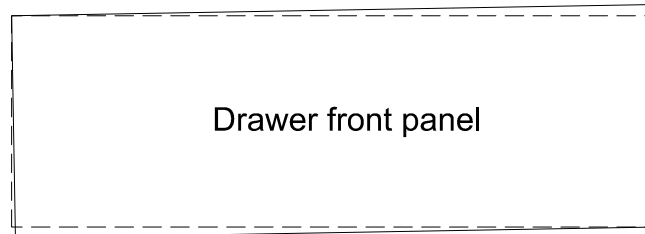



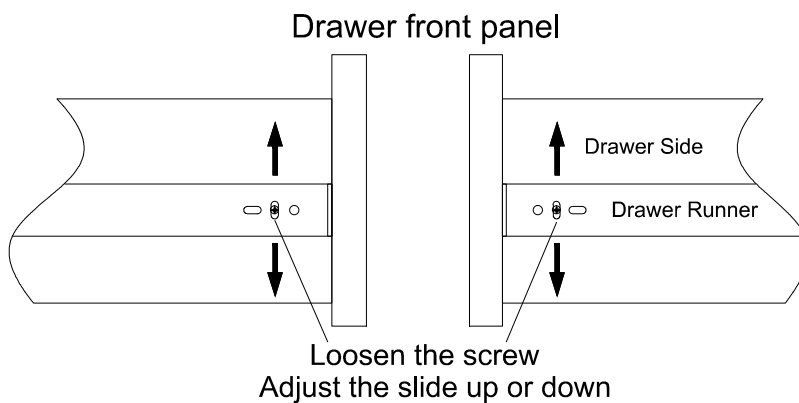





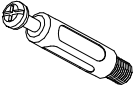

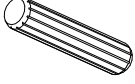
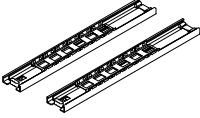

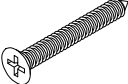
If the drawer front panel is NOT level after being assembled, then...

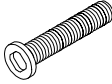
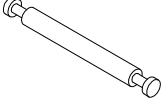

Loosen the screws on the left and right hand side, then adjust the drawer slide up or down, until the drawer fronts are even/level, then tighten the screws.

# Part List

<p><b>No. A</b> Quantity: 24 Pcs Cam Lock Dowel 8*28mm</p> 	<p><b>No. B</b> Quantity: 40 Pcs Cam φ15</p> 	<p><b>No. C</b> Quantity: 40 Pcs Sticker Ø20</p> 	<p><b>No. D</b> Quantity: 22 Pcs Dowel 8*30mm</p> 
<p><b>No. E</b> Quantity: 2 Sets Drawer Slider 10"</p> 	<p><b>No. F</b> Quantity: 16 Pcs Screw M3.5*12mm</p> 	<p><b>No. G</b> Quantity: 8 Pcs Screw M4*30mm</p> 	<p><b>No. H</b> Quantity: 16 Pcs Screw M6*40mm</p> 
<p><b>No. I</b> Quantity: 3 Pcs Foot Pad Ø20</p> 	<p><b>No. J</b> Quantity: 12 Pcs Screw M8*20mm</p> 	<p><b>No. K</b> Quantity: 16 Pcs Screw M8*40mm</p> 	<p><b>No. L</b> Quantity: 8 Pcs Double-ended rod 6*64mm</p> 
<p><b>No. M</b> Quantity: 8 Pcs Allen Key 4#</p> 	<p><b>No. N</b> Quantity: 1 Pcs Allen Key 5#</p> 	<p><b>No. O</b> Quantity: 10 Pcs Gasket Ø13</p> 	<p><b>No. P</b> Quantity: 10 Pcs Gasket</p> 

# Product structure

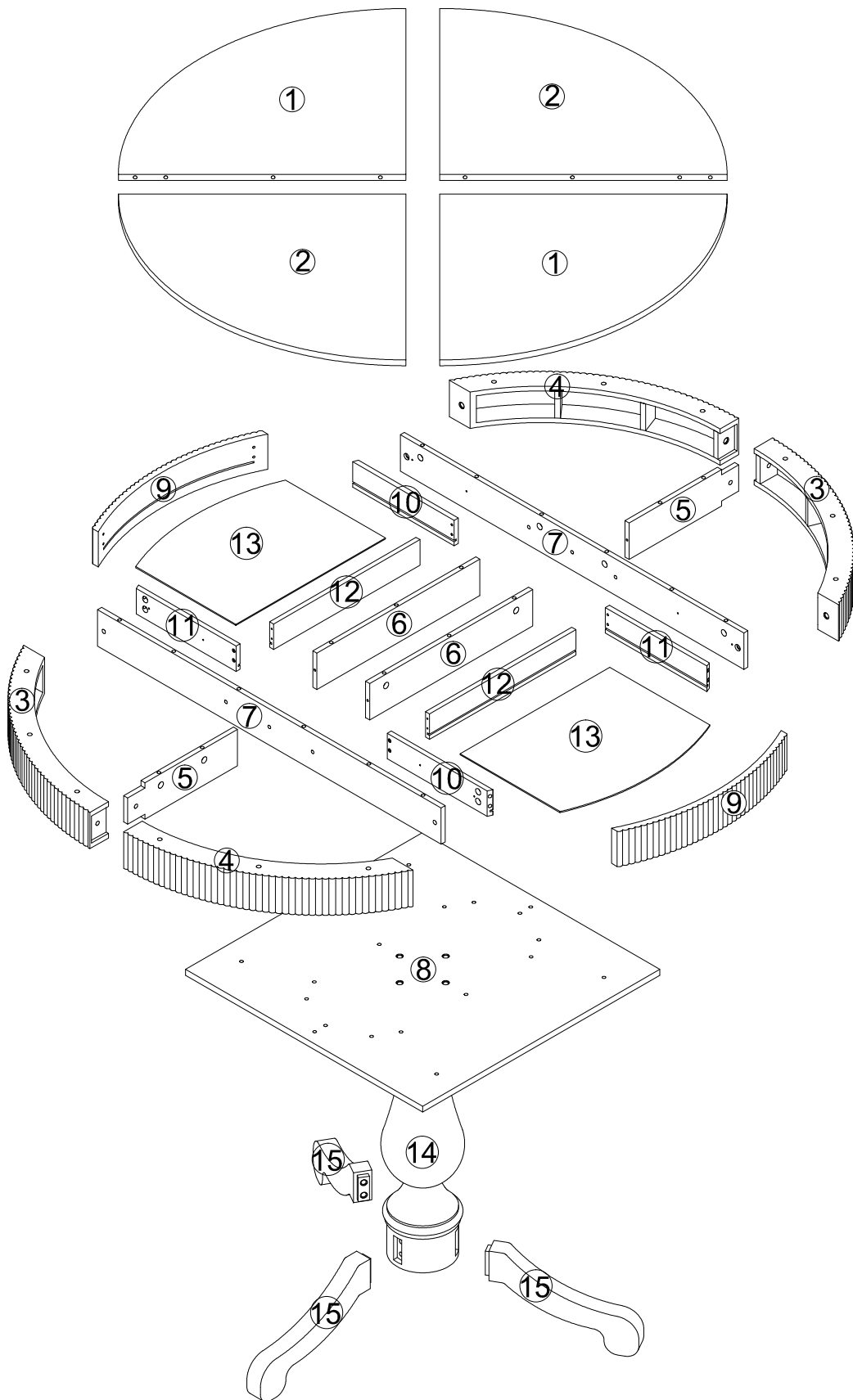

# STEP 1

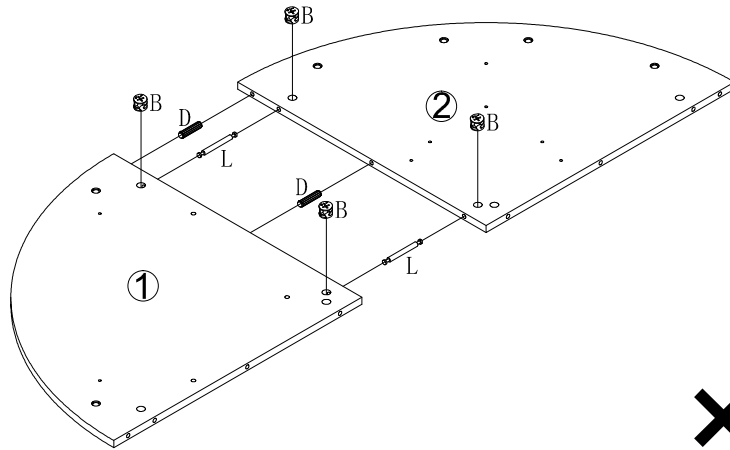

**x2**

No. B  
Quantity: 8 Pcs  
Ø15



No. D  
Quantity: 4 Pcs  
8\*30mm

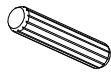

No. L  
Quantity: 4 Pcs  
6\*64mm

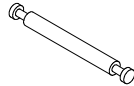

# STEP 2

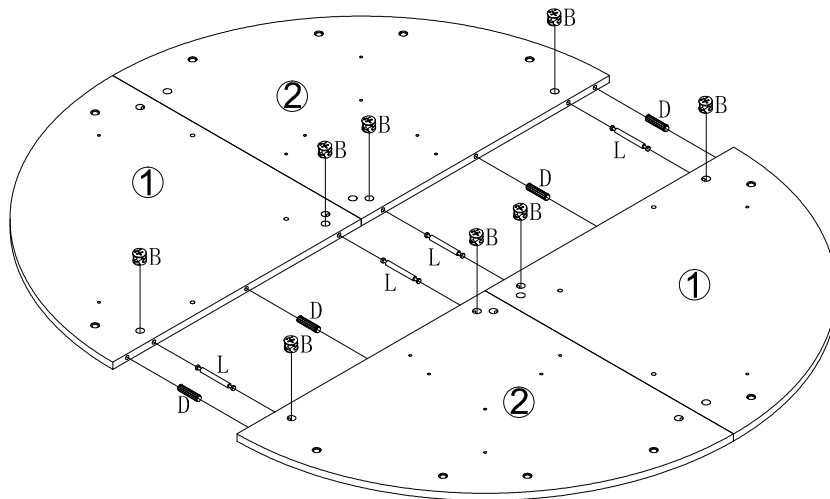

No. B  
Quantity: 8 Pcs  
Ø15



No. D  
Quantity: 4 Pcs  
8\*30mm

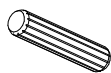

No. L  
Quantity: 4 Pcs  
6\*64mm

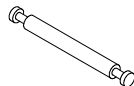

# STEP 3

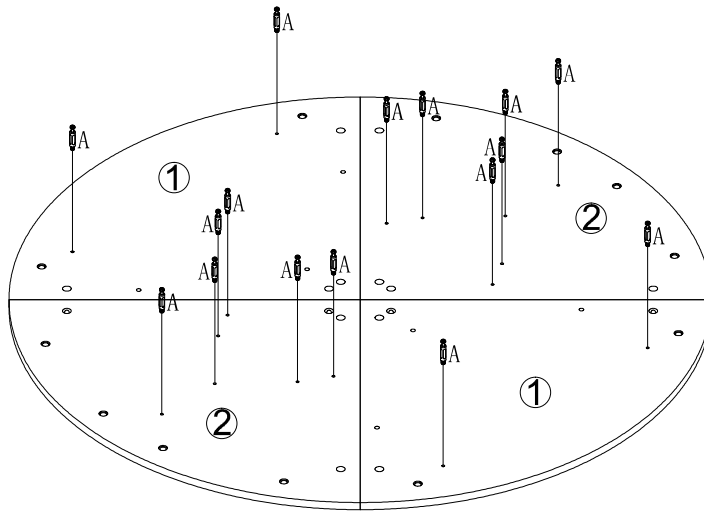

No. A  
Quantity: 16 Pcs  
8\*28 mm



# STEP 4

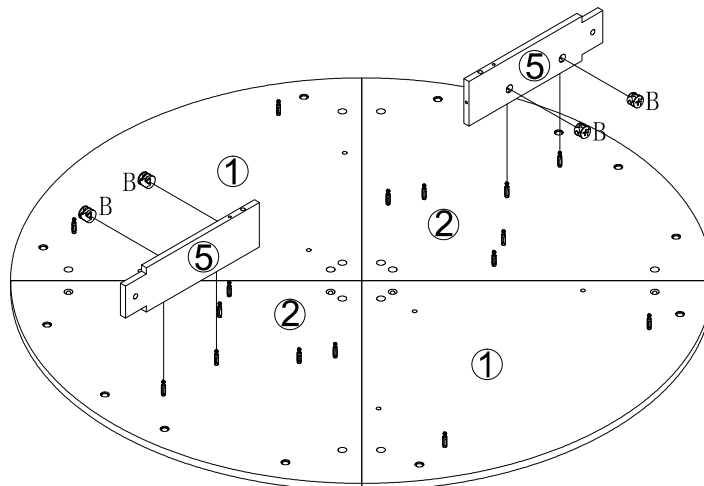

No. B  
Quantity: 4 Pcs  
Ø15



# STEP 5

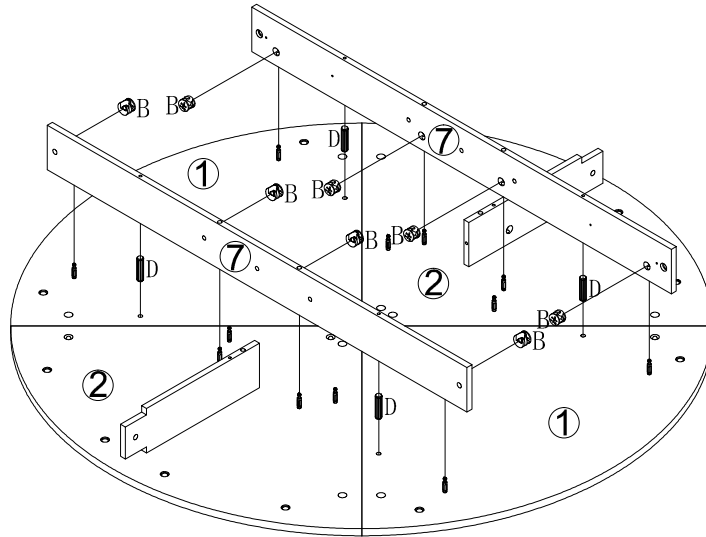

No. B  
Quantity: 8 Pcs  
Ø15



No. D  
Quantity: 4 Pcs  
8\*30mm

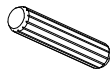

# STEP 6

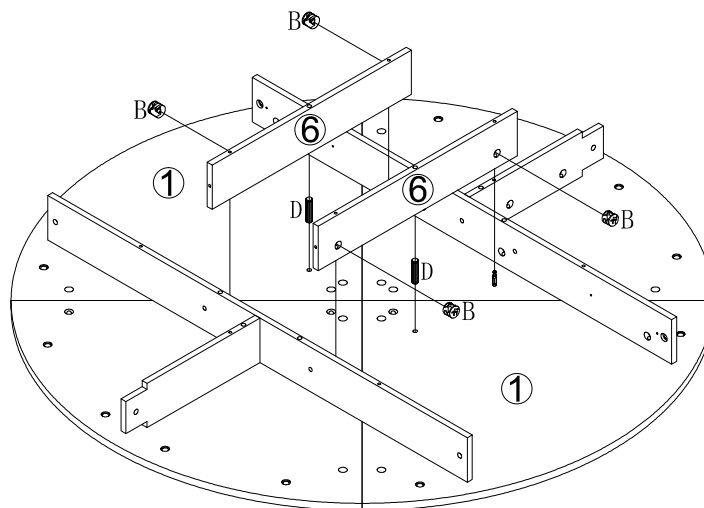

No. B  
Quantity: 4 Pcs  
Ø15



No. D  
Quantity: 2 Pcs  
8\*30mm

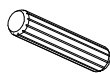

# STEP 7

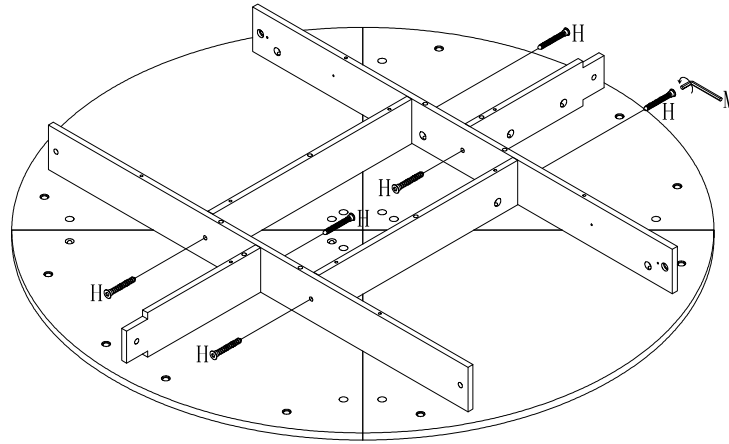

No. H  
Quantity: 6 Pcs  
M6\*40mm



No. M  
Quantity: 1 Pcs  
4#



# STEP 8

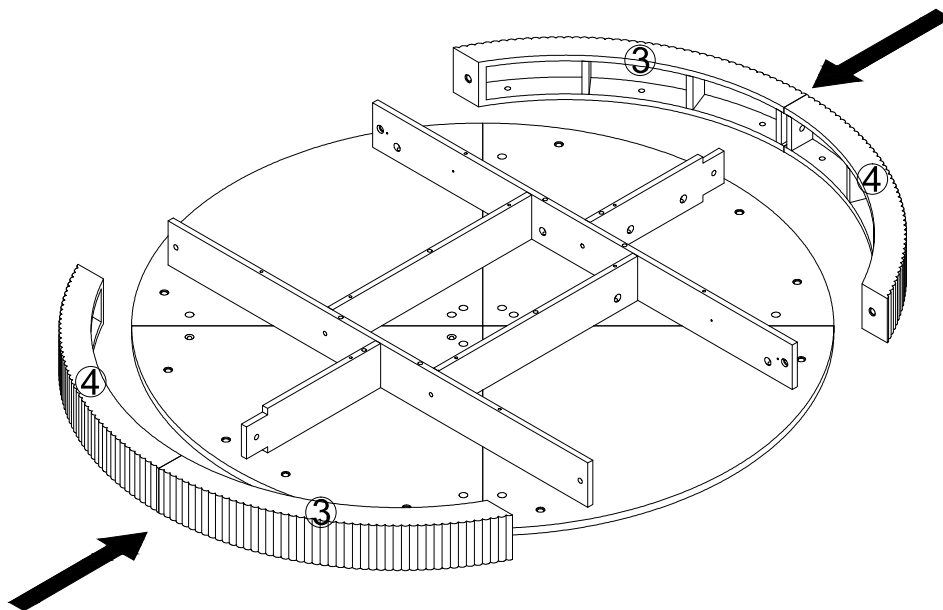

# STEP 9

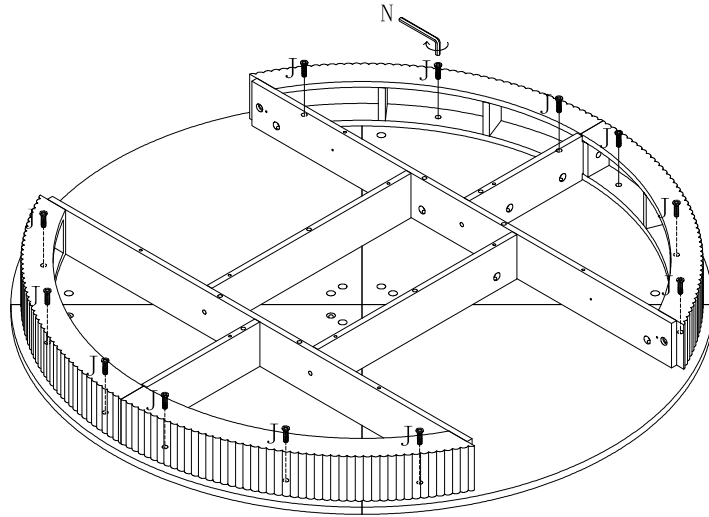

No. J  
Quantity: 12 Pcs  
M8\*20mm



No. N  
Quantity: 1 Pcs  
5#

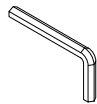

# STEP 10

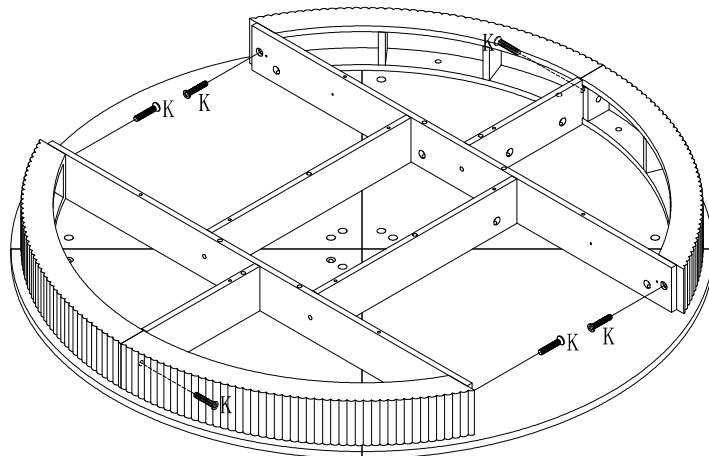

No. K  
Quantity: 6 Pcs  
M8\*40mm

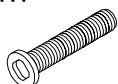

No. N  
Quantity: 1 Pcs  
5#

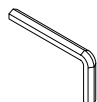

# STEP 11

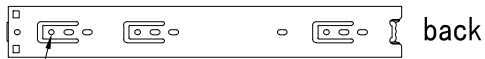

The first screw hole should corresponded with the board location hole

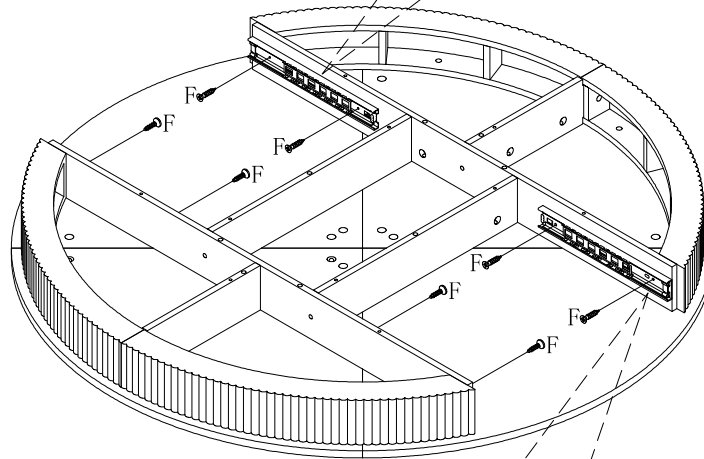
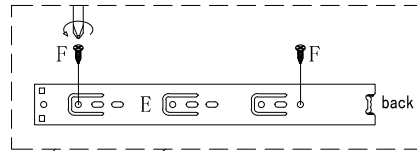

No. E  
Quantity: 2 Sets  
10"

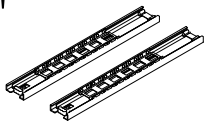

No. F  
Quantity: 8 Pcs  
M3.5\*12mm

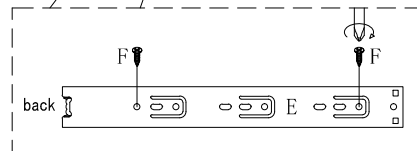

# STEP 12

No. D  
Quantity: 8 Pcs  
8\*30mm

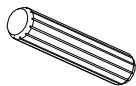

No. H  
Quantity: 10 Pcs  
M6\*40mm



No. M  
Quantity: 1 Pcs  
4#

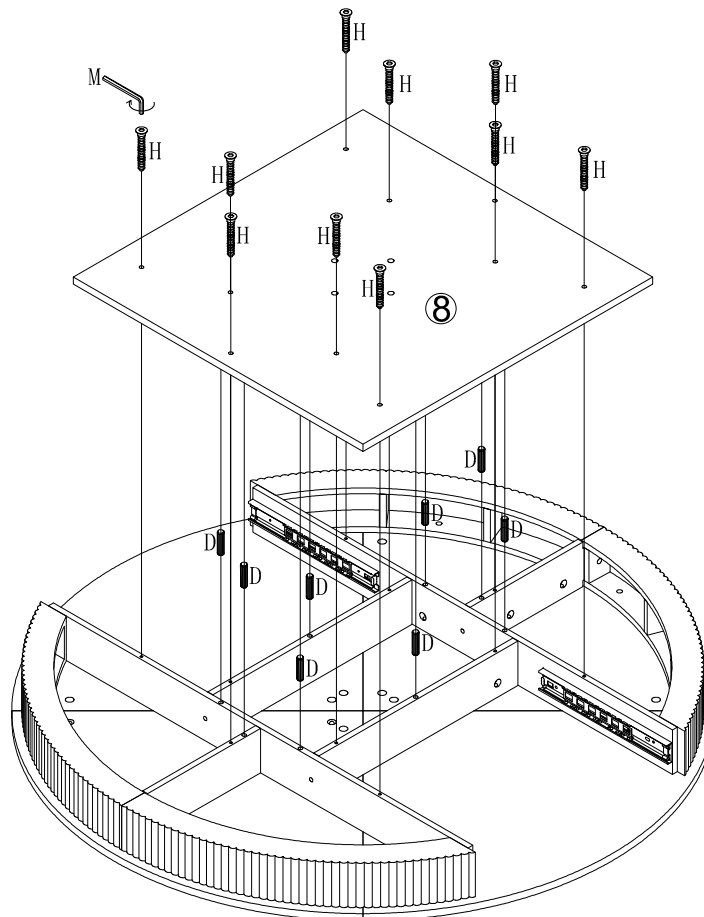

# STEP 13

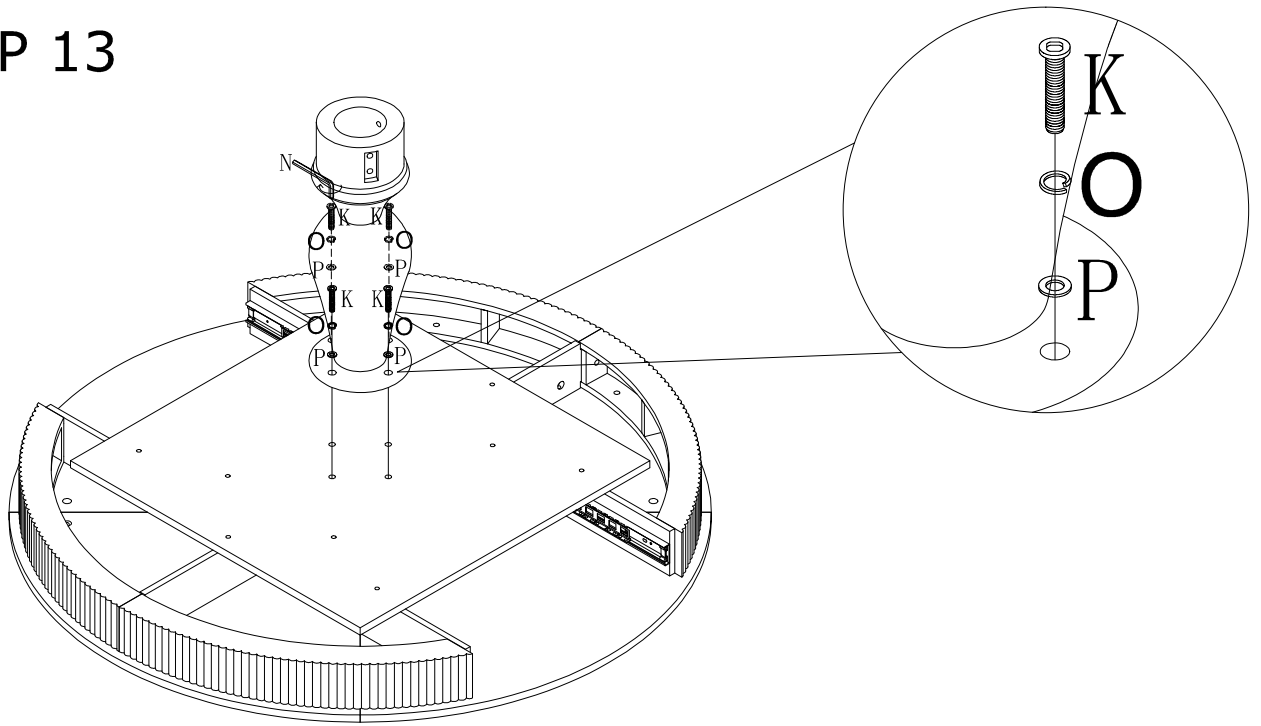

No. K  
Quantity: 4 Pcs  
M8\*40mm

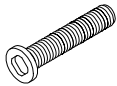

No. N  
Quantity: 1 Pcs  
5#



No. O  
Quantity: 4 Pcs  
Ø13



No. P  
Quantity: 4 Pcs



# STEP 14

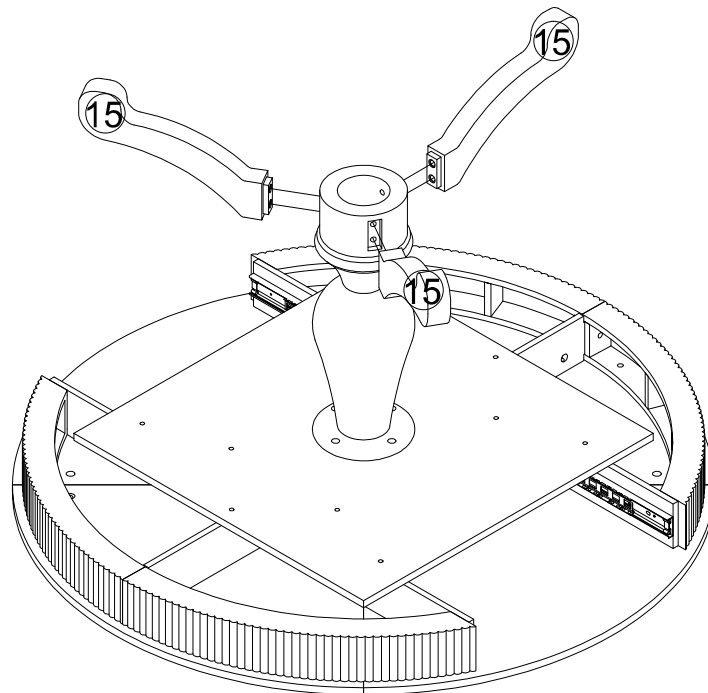

# STEP 15

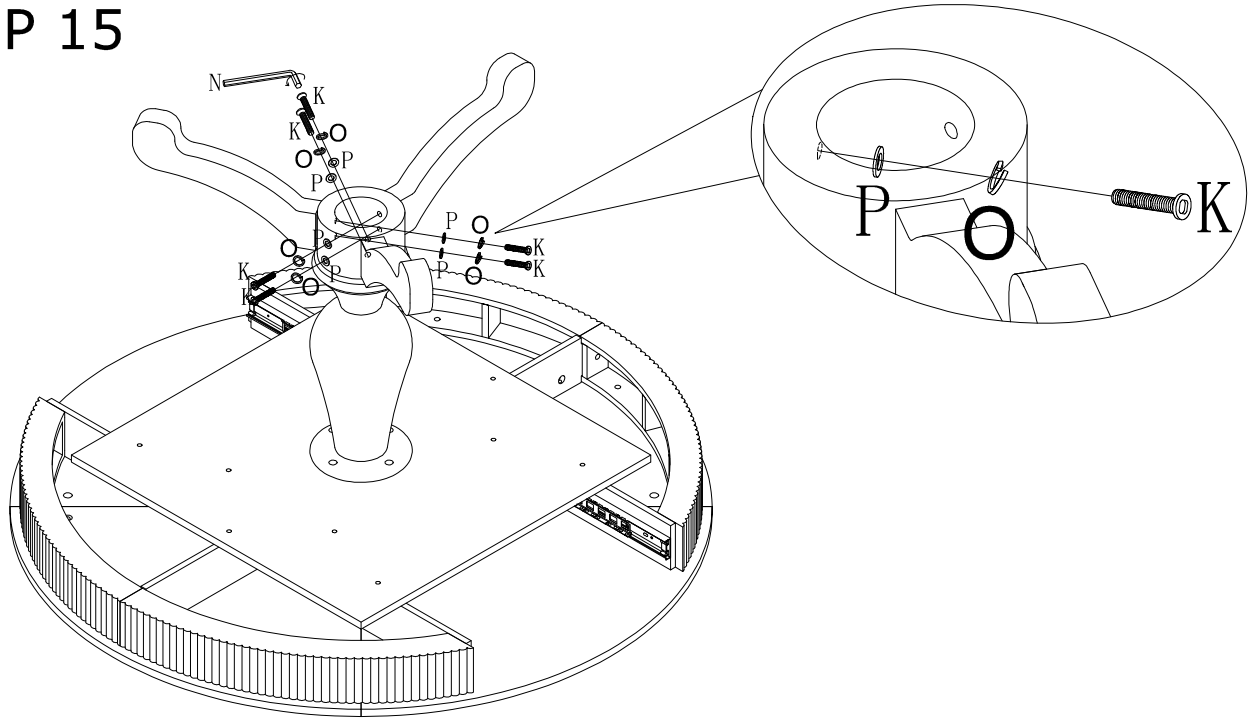

No. K  
Quantity: 6 Pcs  
M8\*40mm

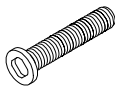

No. N  
Quantity: 1 Pcs  
5#



No. O  
Quantity: 6 Pcs  
Ø13



No. P  
Quantity: 6 Pcs



# STEP 16

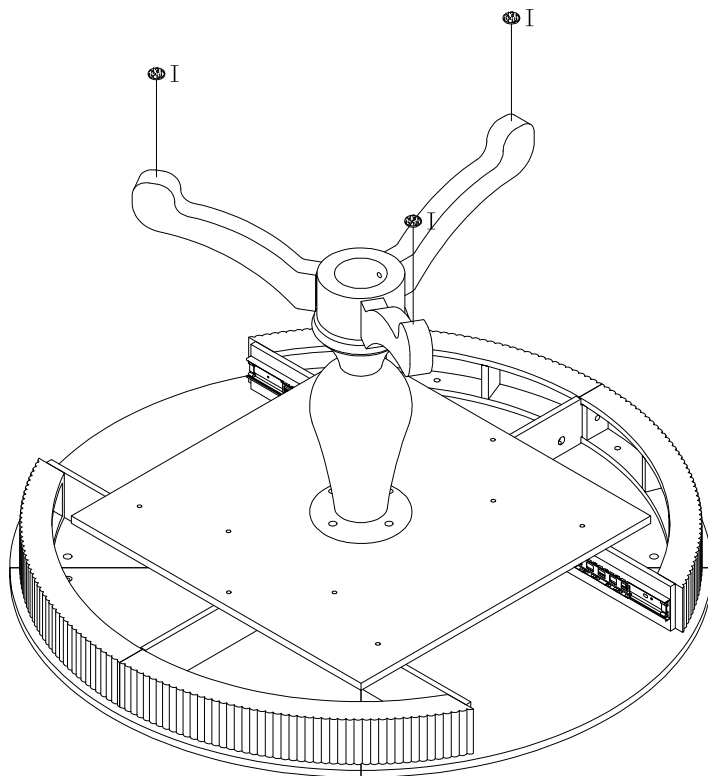

No. I  
Quantity: 3 Pcs  
Ø20



# STEP 17

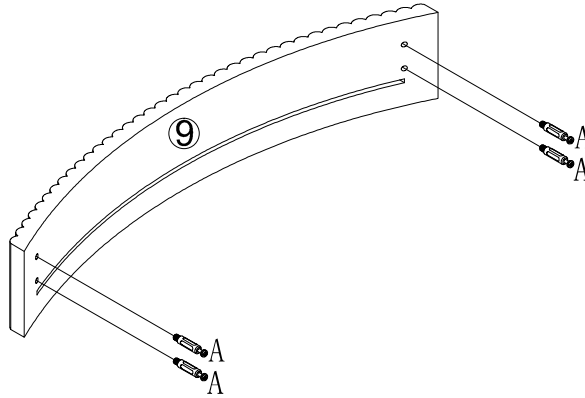

**x2**

No. A  
Quantity: 8 Pcs  
8\*28 mm



# STEP 18

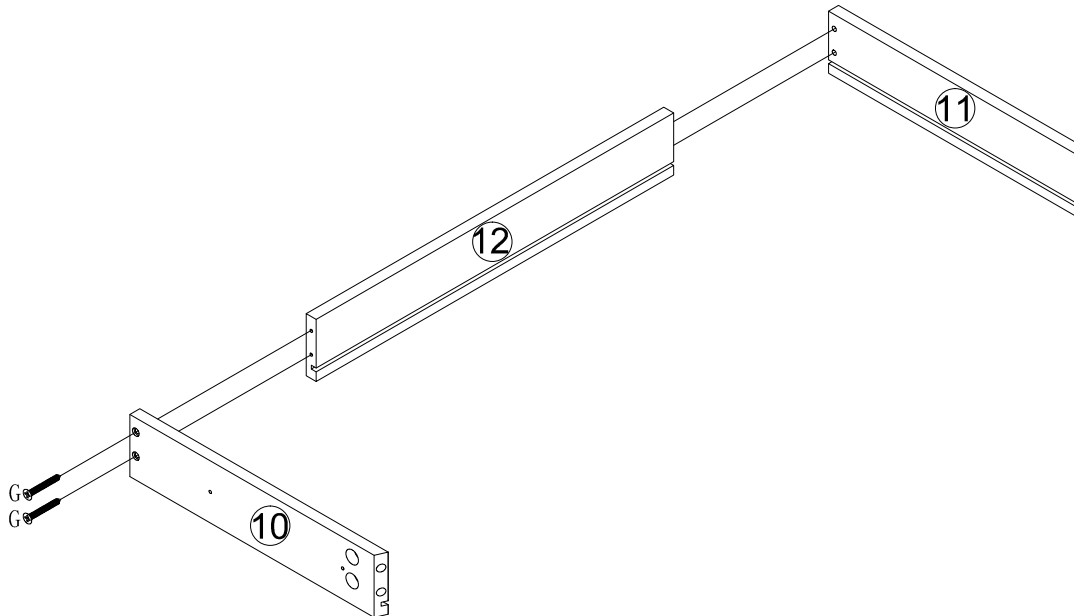

**x2**

No. G  
Quantity: 8 Pcs  
M4\*30mm

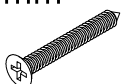

# STEP 19

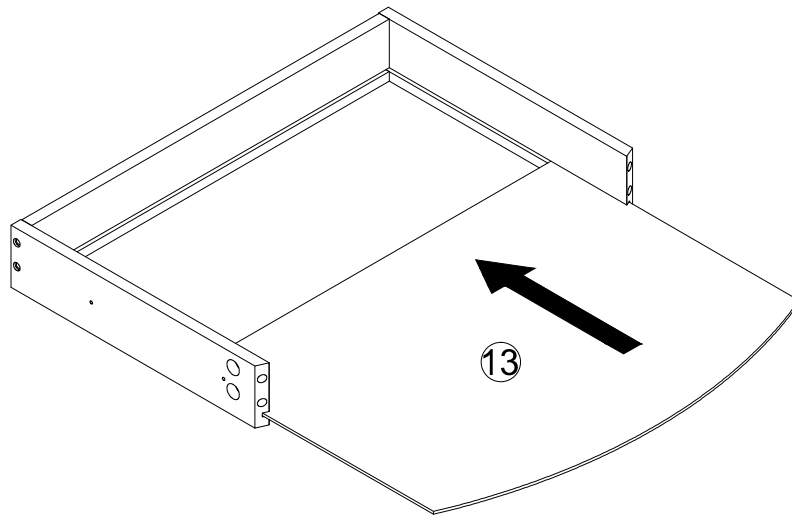

**x2**

# STEP 20

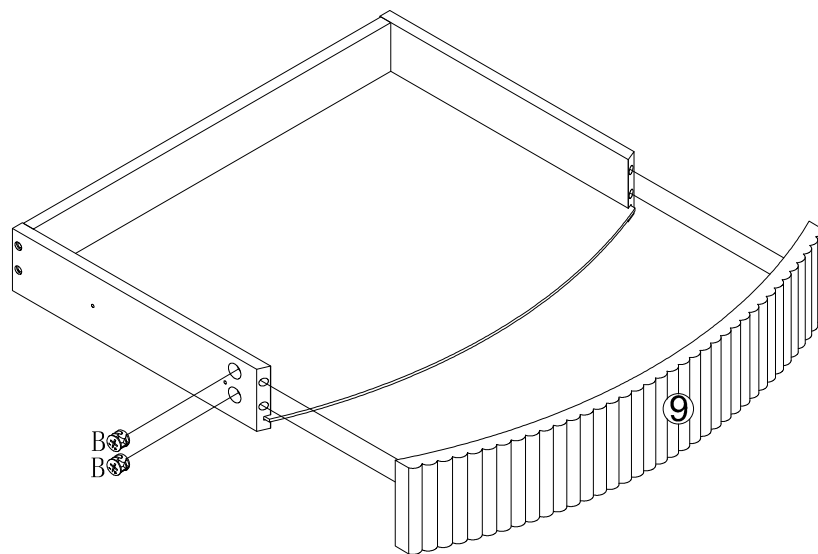

**x2**

No. B  
Quantity: 8 Pcs  
Ø15



## STEP 21

 back

The first screw hole should corresponded with the board location hole

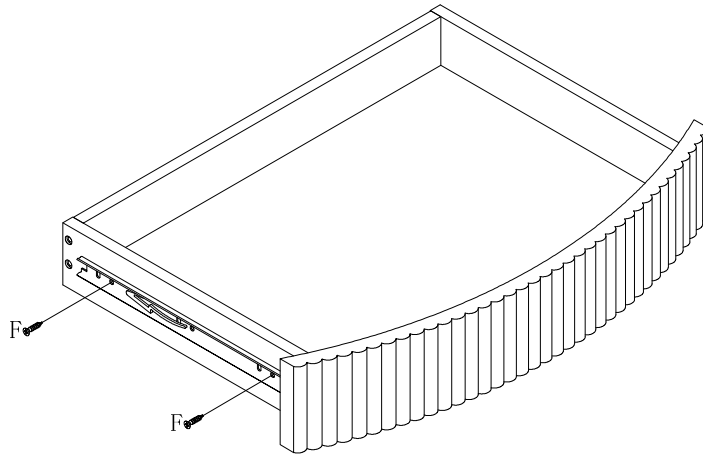

No. E  
Quantity: 2 Sets  
10"

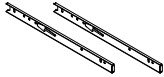

No. F  
Quantity: 8 Pcs  
M3.5\*12mm



**x2**

## STEP 22

