

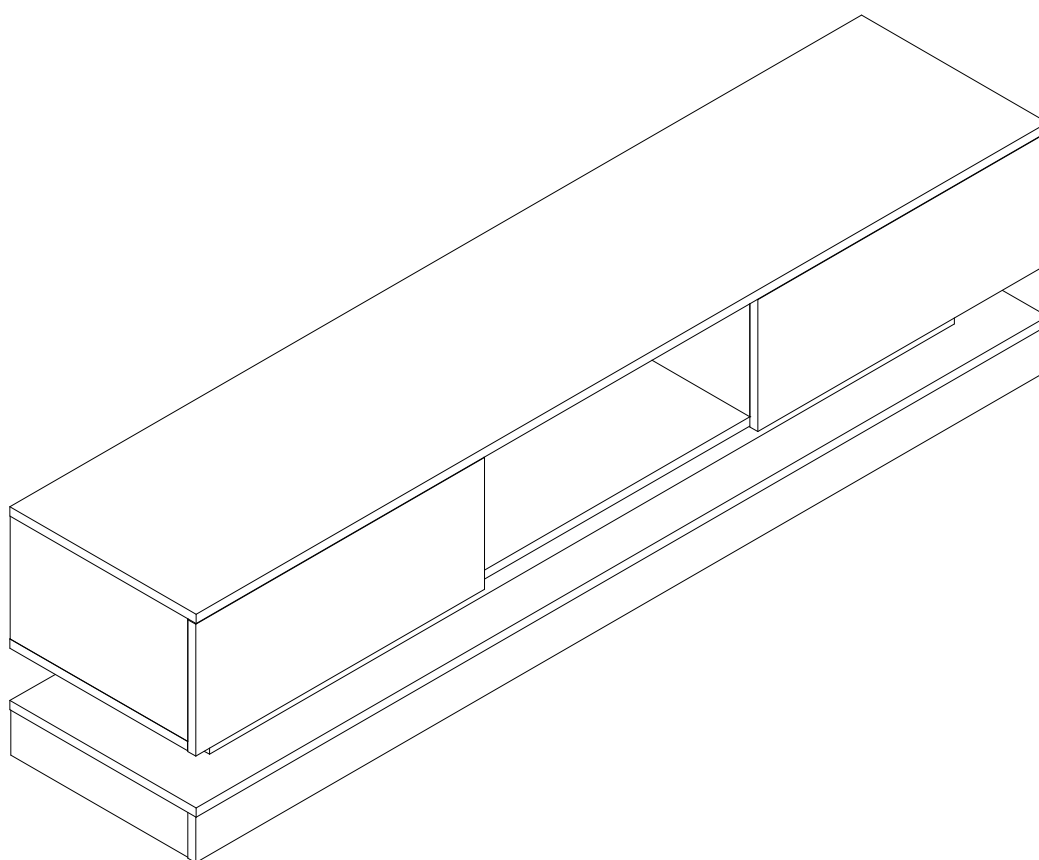

Product manual



Our product will be delivered to you in 2 packages. The delivery times of these 2 packages may differ, please be patient and thank you for your understanding.

 2PERS	 45 MIN	Tool Required Not Provided	
			

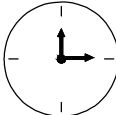
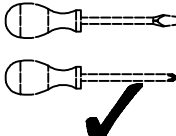
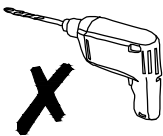
Sicherheits- und Pflegehinweise

Wichtig: Bitte lesen Sie diese Anweisungen vollständig durch, bevor Sie mit der Montage beginnen.

Achtung: Dieses Gerät ist relativ schwer. Bitte heben Sie es vorsichtig an. Überprüfen Sie, ob alle auf den Seiten aufgeführten Komponenten und Werkzeuge vorhanden sind.

Entfernen Sie sämtliches Zubehör aus den Plastiktüten und teilen Sie es in seine Gruppen auf.

Halten Sie Kinder und Tiere vom Arbeitsbereich fern, Kleinteile könnten beim Verschlucken ersticken. Teile der Montage sind mit 2 Personen einfacher.

Stellen Sie sicher, dass Sie genügend Platz haben, um die Teile anzuordnen, bevor Sie beginnen.

Stellen Sie sich nicht auf das Produkt und belasten Sie es nicht, dies könnte zu Schäden führen.

Montieren Sie den Gegenstand so nah wie möglich an seiner endgültigen Position im selben Raum.

Montieren Sie das Gerät auf einer weichen, ebenen Oberfläche, um eine Beschädigung des Geräts oder Ihres Bodens zu vermeiden. Verwenden Sie dazu den geöffneten Gerätekarton.

Pflege und Wartung

Reinigen Sie das Gerät nur mit einem feuchten Tuch und einem milden Reinigungsmittel.

Verwenden Sie keine Bleichmittel oder Scheuermittel. Überprüfen Sie von Zeit zu Zeit, ob sich an diesem Gerät keine Schrauben gelöst haben.

(Notiz)

Bei Bedarf kann die nächste Seite ausgeschnitten und während der gesamten Zusammenstellung als Referenz verwendet werden.

Bewahren Sie diese Seite zusammen mit diesen Anweisungen zum späteren Nachschlagen im Produkthandbuch auf.

Dieses Produkt besteht aus 2 Logistikpaketen. Bitte überprüfen Sie die Anzahl Ihrer Pakete. Wenn eines fehlt, wenden Sie sich bitte an die Logistik.

Bitte lesen Sie alle Vorsichtsmaßnahmen und Anweisungen in diesem Handbuch, bevor Sie dieses Produkt verwenden.

Wenn Sie Fragen zu diesem Produkt haben, wenden Sie sich bitte rechtzeitig an Ihren Lieferanten.



COMHARBOR LIMITED
Unit C, Swift Point, Cosford Lane, Rugby, CV21 1PY



Safety and Care Advice

Important - Please read these instructions fully before starting assembly

Warning: This unit is relatively heavy. Please lift with care. Check you have all the components and tools listed on pages.

Remove all fittings from the plastic bags and separate them into their groups.

Keep children and animals away from the work area, small parts could choke if swallowed. Parts of the assembly will be easier with 2 people.

Make sure you have enough space to layout the parts before starting. Do not stand or put weight on the product, this could cause damage.

Assemble the item as close as possible to its final position in the same room.

Assemble on a soft level surface to avoid damaging the unit or your floor use opened out unit carton.

Care and maintenance

Only clean using a damp cloth and mild detergent, do not use bleach or abrasive cleaners. From time to time check that there are no loose screws on this unit.

(Note)

If required the next page can be cut out and used as reference throughout the assembly.

Keep this page with these instructions for future reference Product Manual.

This product consists of 2 logistics packages, please check the number of your packages, if there is any missing, please contact the logistics.

Please read all precautions and instructions in this manual before using this product.

If you have any questions about this product, please contact your supplier in time.

Conseils de sécurité et d'entretien

Important - Veuillez lire entièrement ces instructions avant de commencer l'assemblage

Attention : cet appareil est relativement lourd. Veuillez soulever avec précaution. Vérifiez que vous disposez de tous les composants et outils répertoriés sur les pages.

Retirez tous les raccords des sacs en plastique et séparez-les en groupes.

Gardez les enfants et les animaux éloignés de la zone de travail, les petites pièces pourraient s'étouffer en cas d'ingestion. Les pièces de l'assemblage seront plus faciles à 2 personnes.

Assurez-vous de disposer de suffisamment d'espace pour disposer les pièces avant de commencer. Ne vous tenez pas debout et ne mettez pas de poids sur le produit, cela pourrait l'endommager.

Assemblez l'objet le plus près possible de sa position finale dans la même pièce.

Assemblez sur une surface douce pour éviter d'endommager l'unité ou votre sol, utilisez le carton de l'unité ouvert.

Entretien et maintenance

Nettoyez uniquement à l'aide d'un chiffon humide et d'un détergent doux, n'utilisez pas d'eau de Javel ni de nettoyeurs abrasifs. Vérifiez de temps en temps qu'il n'y a pas de vis desserrées sur cet appareil.

(Note)

Si nécessaire, la page suivante peut être découpée et utilisée comme référence tout au long de l'assemblage.

Conservez cette page avec ces instructions pour référence future du manuel du produit.

Ce produit se compose de 2 colis logistiques, veuillez vérifier le numéro de vos colis, s'il en manque, veuillez contacter la logistique.

Veuillez lire toutes les précautions et instructions de ce manuel avant d'utiliser ce produit.

Si vous avez des questions sur ce produit, veuillez contacter votre fournisseur à temps.



EN_QUICKFIT: Tighten quickfit until shoulder is flush with panel. Do not overtighten or undertighten.

FR_RACCORD RAPIDE: Faites serrer le raccord rapide jusqu'à ce que l'épaulement soit parfaitement encastré dans le panneau. Il ne faut ni trop serrer ni insuffisamment serrer.

ES_QUICKFIT: Apriete quickfit hasta que el hombro se descargue con el panel. NO lo sobreapriete ni lo apriete poco.

DE_QUICKFIT: Ziehen Sie den Quickfit fest, bis die Schulter mit der Platte bündig ist. Bitte nicht zu fest oder zu schwach anziehen.

IT_MONTAGGIO RAPIDO: Stringere il montaggio rapido fino a quando la spalla è a filo con il pannello, non stringere troppo o troppo poco.

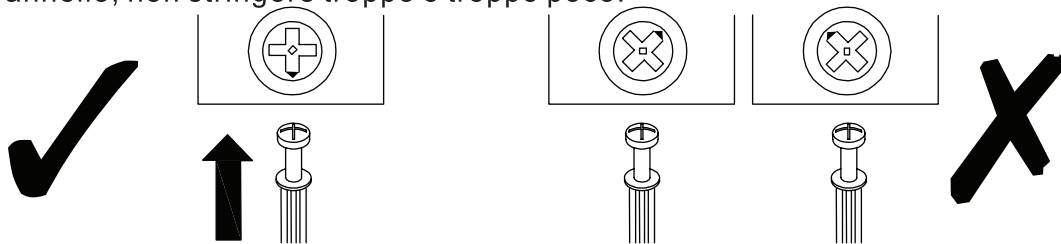

EN_CAM LOCK: When fitting cam lock, ensure starting position is correct before you insert connecting quickfit.

FR_SERRURE BATTEUSE: Avant d'insérer la serrure batteuse, veillez à la bonne orientation avant d'insérer le raccord rapide.

ES_CIERRE DE LA CÁMARA: Cuando instale el cierre de la cámara, asegúrese de que la posición de inicio es correcta antes de que inserte el quickfit conector.

DE_CAM-LOCK: Achten Sie bei der Montage des Cam-Locks auf die richtige Ausgangsposition, bevor Sie den Quickfit einsetzen.

IT_BLOCCAGGIO A CAMMA: Quando si monta il bloccaggio a camma, assicurarsi che la posizione iniziale sia corretta prima di inserire il montaggio rapido di collegamento.



EN_Quickfit head should be in the centre of the cam lock when the two panels are joined.

Cam lock should be inserted before quickfit.

FR_Lorsque les deux panneaux sont assemblés, la tête du raccord rapide doit reposer au centre de la serrure batteuse. Il faut insérer la serrure batteuse avant le raccord rapide.

ES_El cabezal del quickfit debe estar en el centro del cierre de la cámara cuando se unan los dos paneles.

Se debe insertar el cierre de la cámara antes que el quickfit.

DE_Der Quickfit-Kopf sollte sich in der Mitte des Cam-Locks befinden, wenn die beiden Platten zusammengefügt sind. Der Cam-Lock sollte vor dem Quickfit eingesetzt werden.

IT_La testa del montaggio rapido deve trovarsi al centro del bloccaggio a camma quando i due pannelli sono uniti.

Il Bloccaggio a Camma deve essere inserito prima del montaggio rapido.

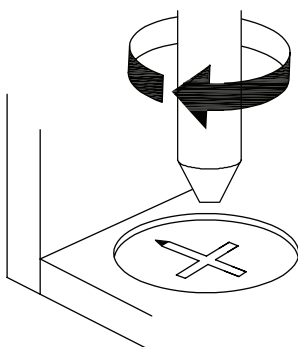

EN_Turn cam lock clockwise to tighten.

FR_Faites tourner la serrure batteuse dans le sens des aiguilles d'une montre pour la resserrer.

ES_Gire el cierre de la cámara en sentido horario para apretarlo.

DE_Drehen Sie den Cam-Lock im Uhrzeigersinn, um ihn festzuziehen.

IT_Ruotare il bloccaggio a camma in senso orario per stringere.

BOX-1/2
N625P170655

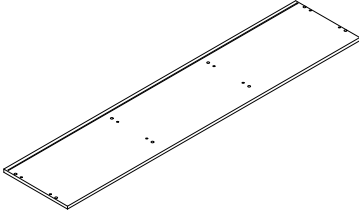
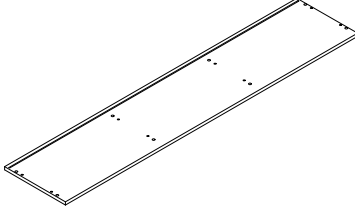
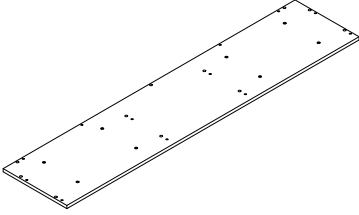
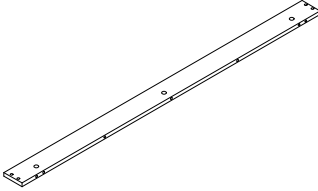
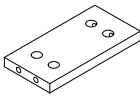
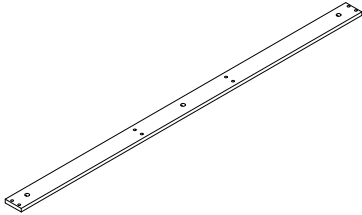
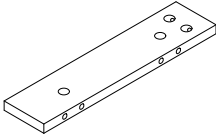
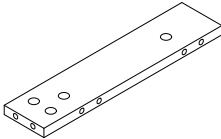
①		1
②		1
③		1
⑨		2
⑩		2
⑪		1
⑫		1
⑬		1

BOX-2/2
N625P170656

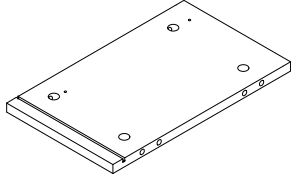
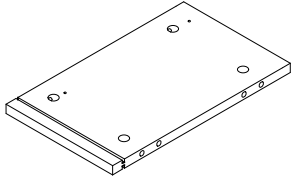
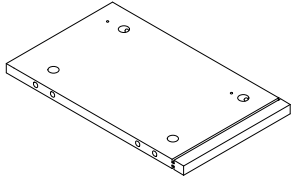
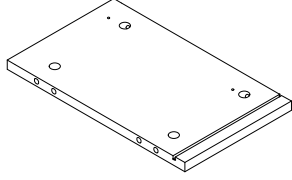
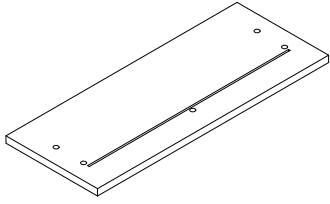
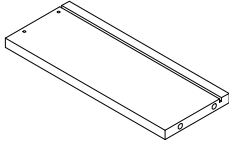
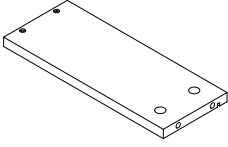
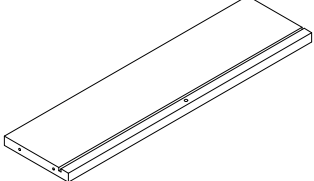
④		1
⑤		1
⑥		1
⑦		1
⑧		2
⑭		2
⑮		2
⑯		2

BOX-1/2
N625P170655

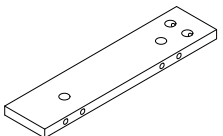



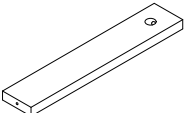
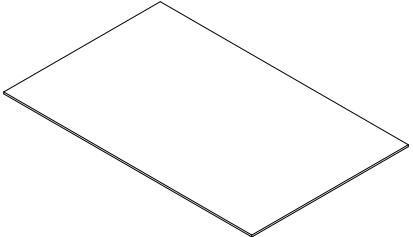
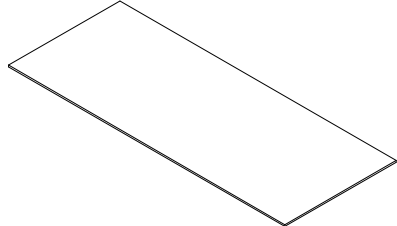
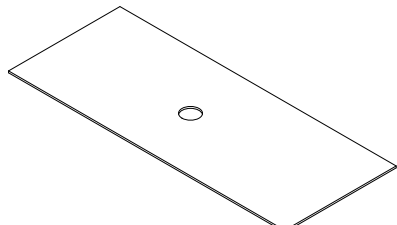
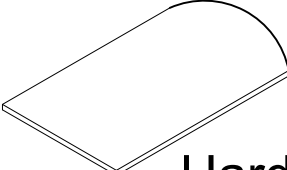

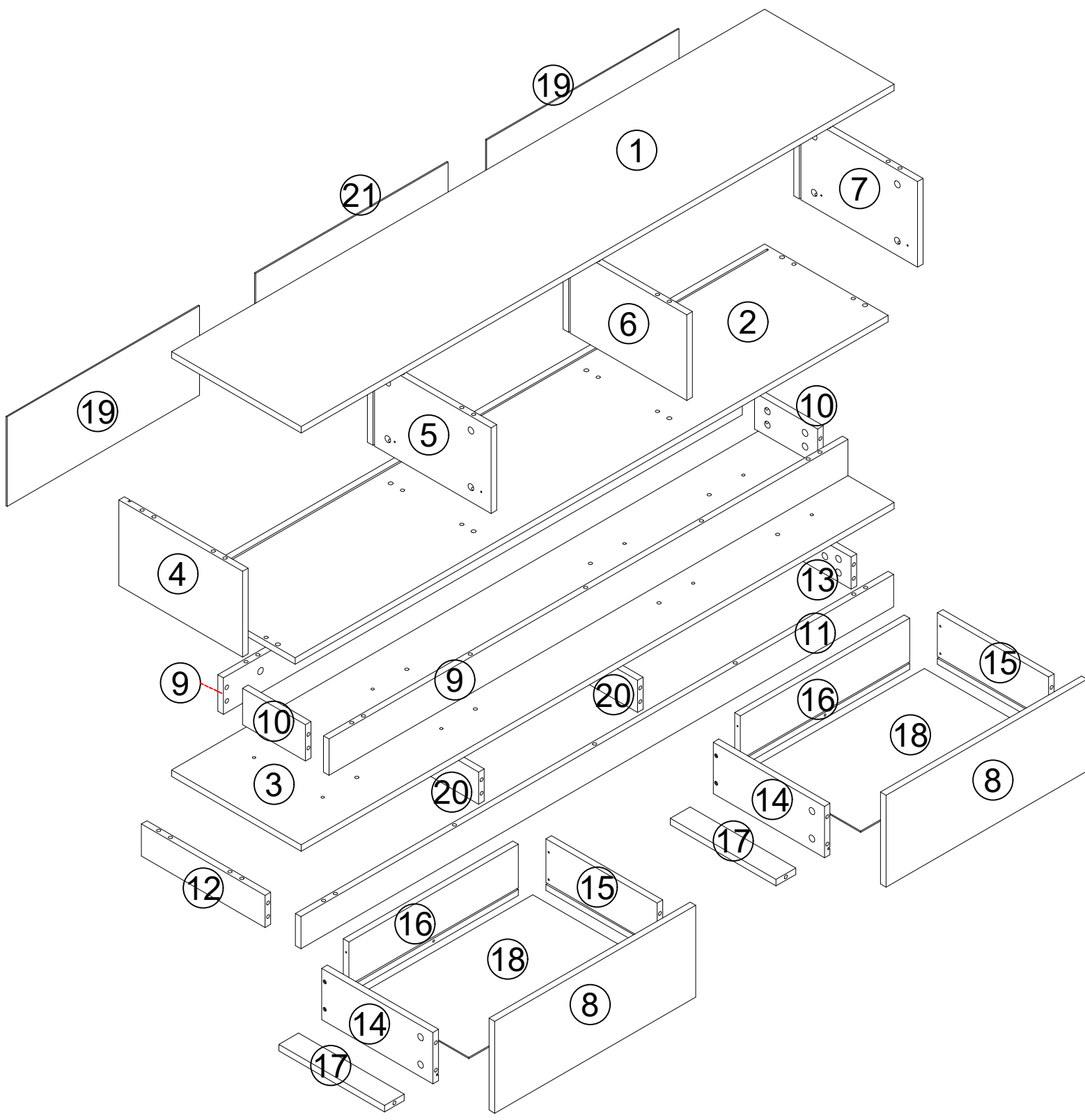
②0		2
----	---	---

BOX-2/2
N625P170656

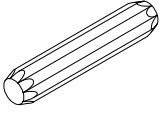
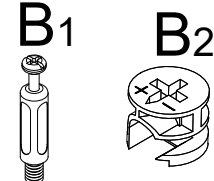
①7		2
①8		2
①9		2
②1		1
 Hardware kit		

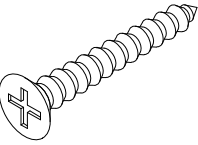
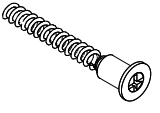
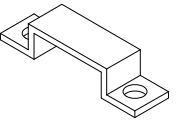

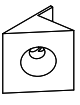
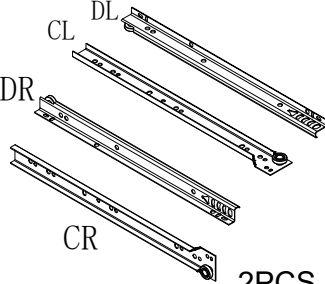

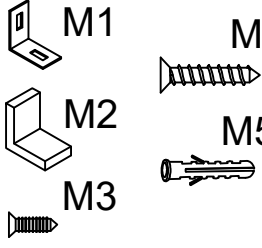
Hardware List for N625P170655/N625P170656

<p>A M8*40</p>  <p>44PCS</p>	<p>B</p> <p>B1 B2</p>  <p>M6*40 59PCS</p>	<p>C M3.5*14</p>  <p>44PCS</p>	<p>D M3.5*35</p>  <p>10PCS</p>
<p>E M7*50</p>  <p>8PCS</p>	<p>F</p>  <p>8PCS</p>	<p>G</p>  <p>1PCS</p>	<p>H</p>  <p>12PCS</p>
<p>CL DL</p> <p>DR</p> <p>CR</p>  <p>2PCS</p>	<p>K</p>  <p>59PCS</p>	<p>M</p> <p>M1 M2 M3</p> <p>M4 M5</p>  <p>2PCS</p>	

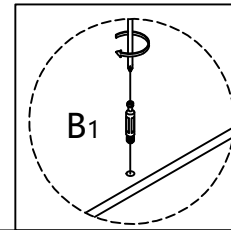
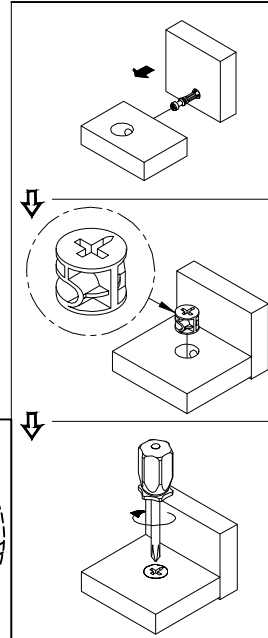
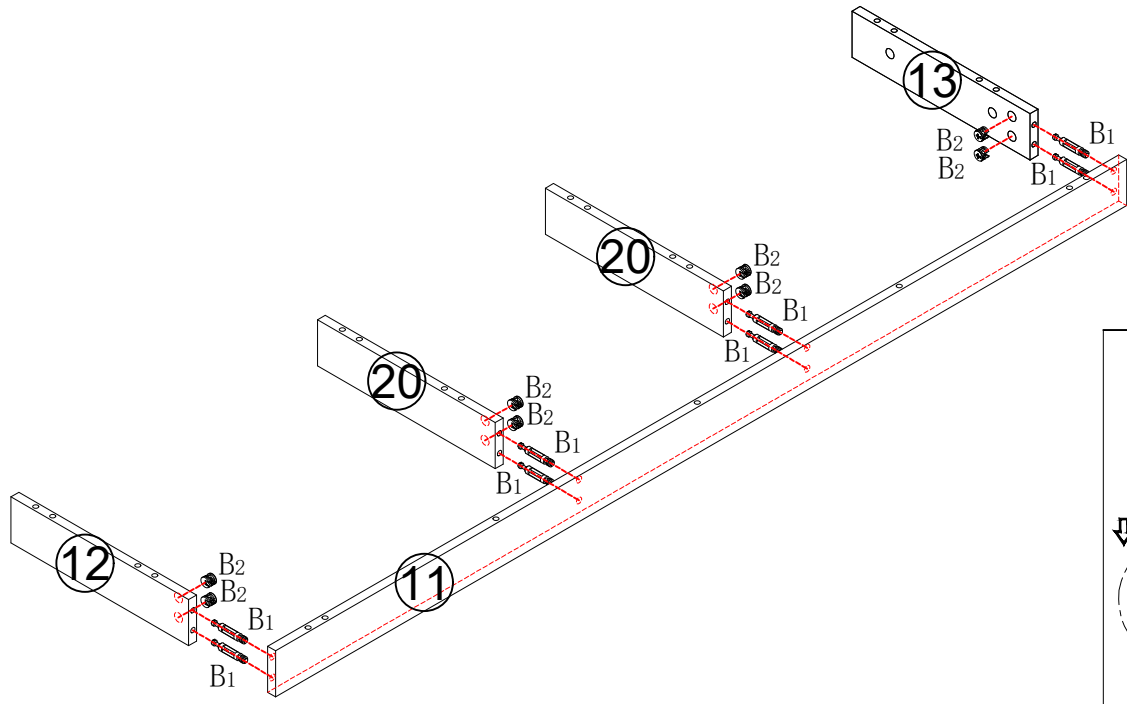

STEP 1



	B ₁ x8pcs
	B ₂ x8pcs

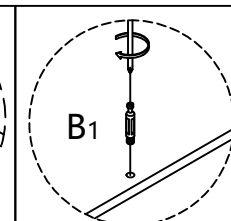
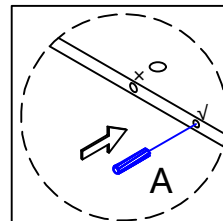
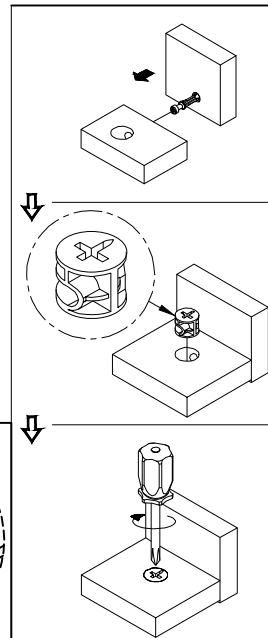
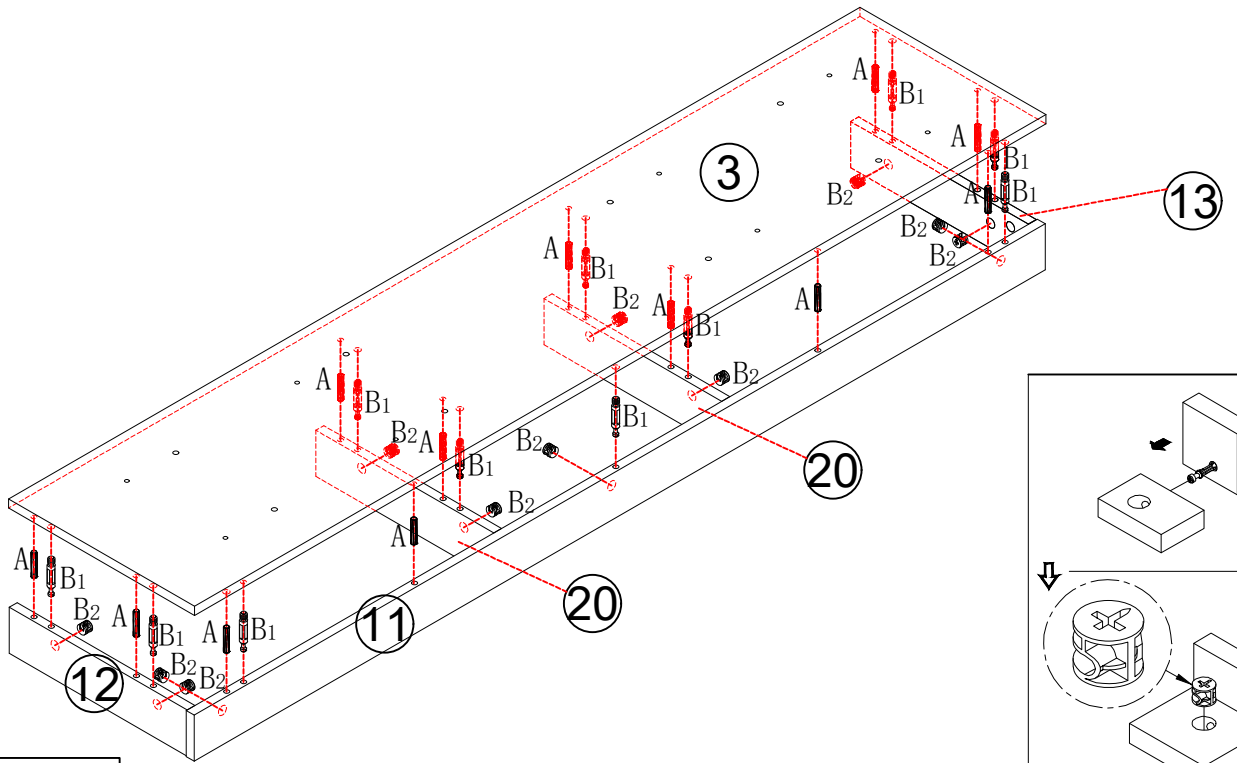

STEP 2



	Ax12pcs
	B ₁ x11pcs
	B ₂ x11pcs

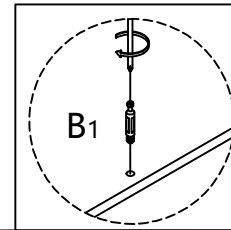
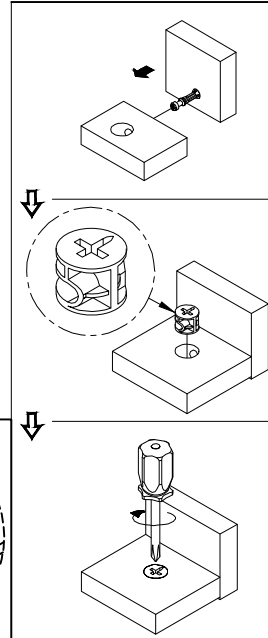
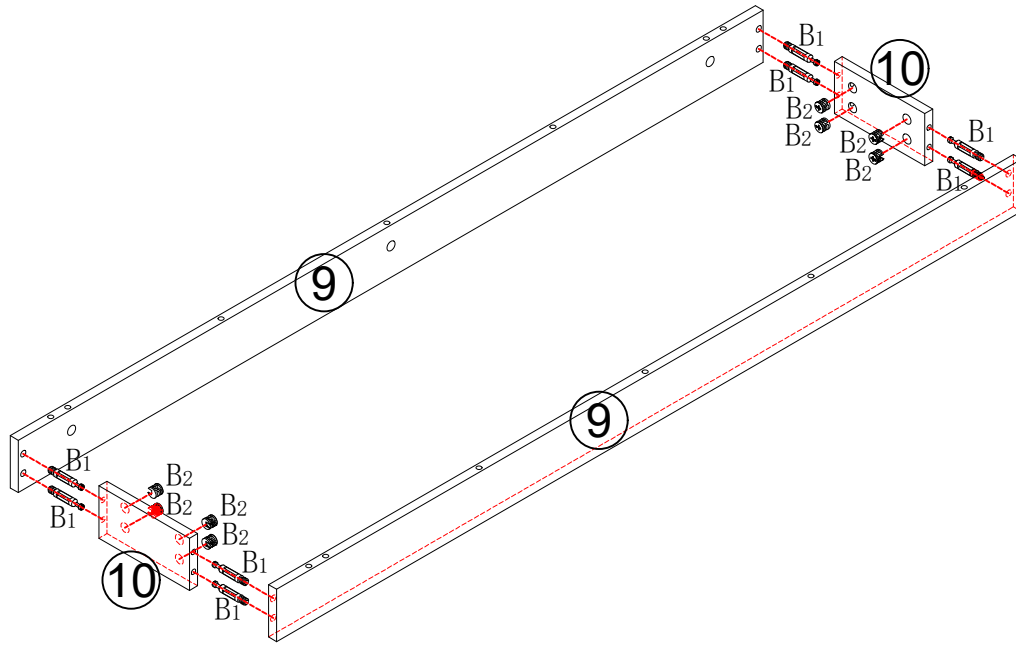

STEP 3

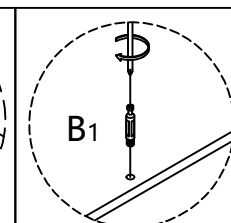
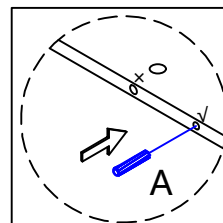
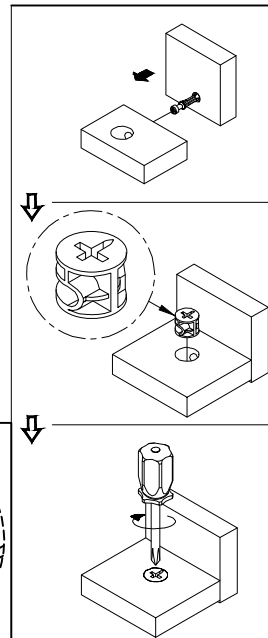
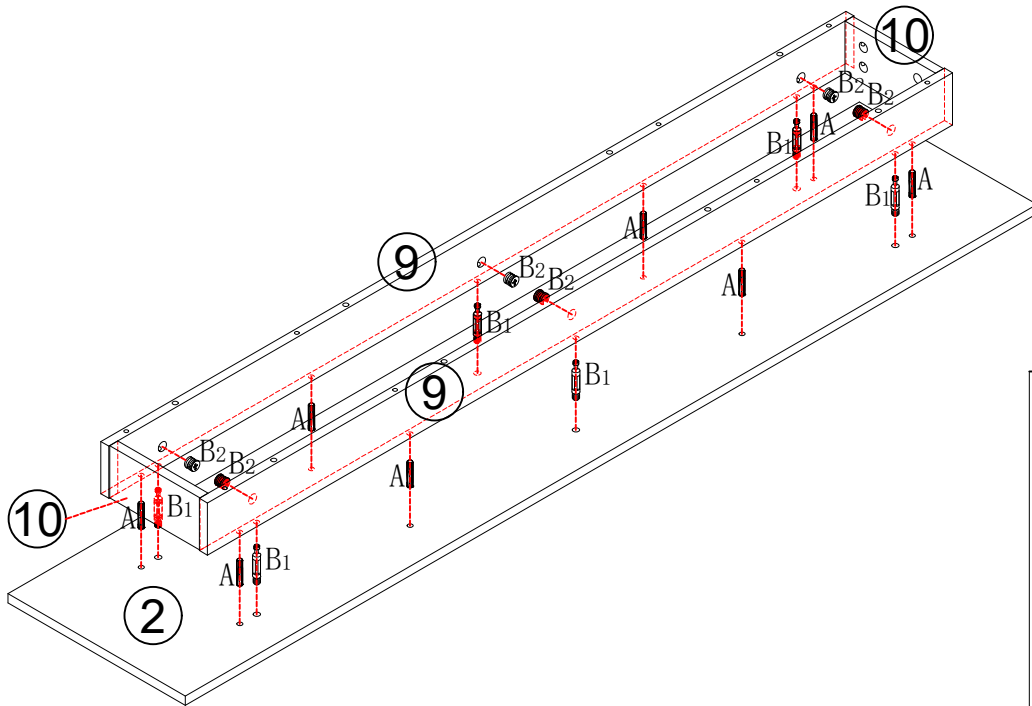

	B ₁ x8pcs
	B ₂ x8pcs

STEP 4





	Ax8pcs
	B ₁ x6pcs
	B ₂ x6pcs

STEP 5

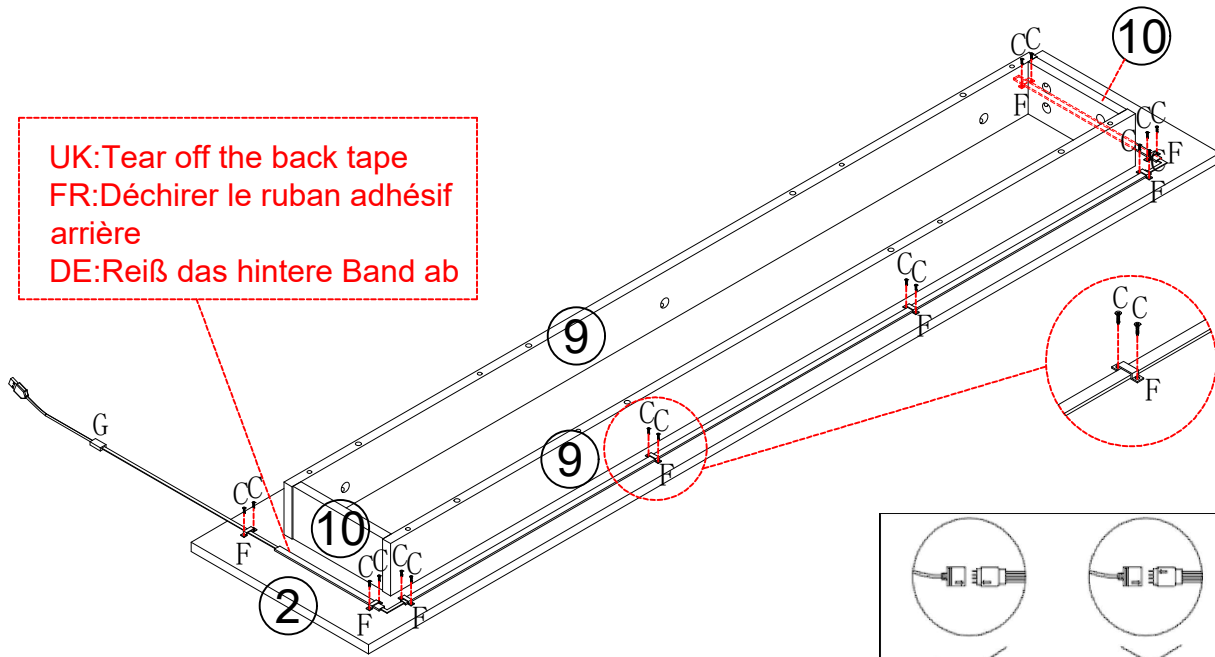
UK: Tear off the back tape
 FR: Déchirer le ruban adhésif arrière
 DE: Reiß das hintere Band ab





	Gx1pcs
	Fx8pcs
	Cx16pcs

UK: The connection of light stripe
 DE: Die Verbindung von Lichtstreifen
 FR: La connexion de la bande lumineuse

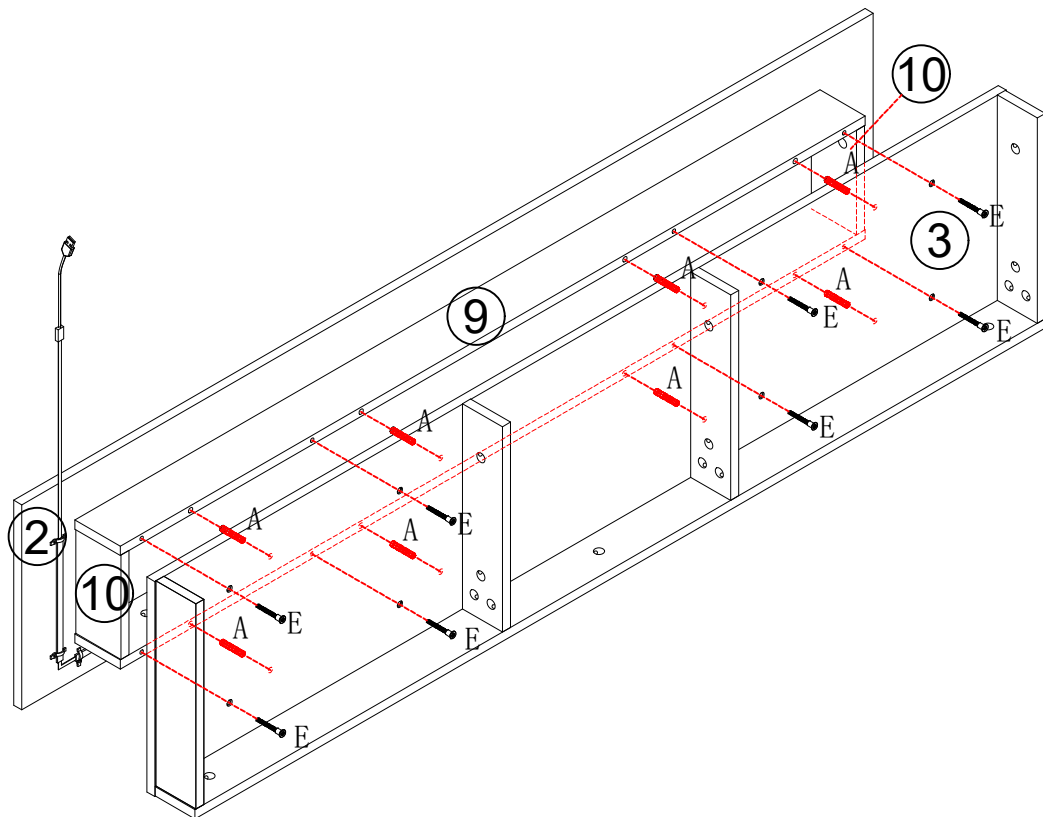
STEP 6



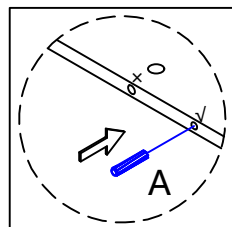

	Ax8pcs
	Ex8pcs

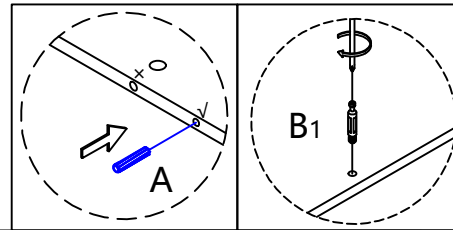
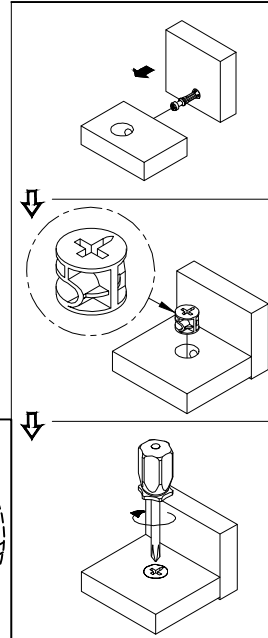
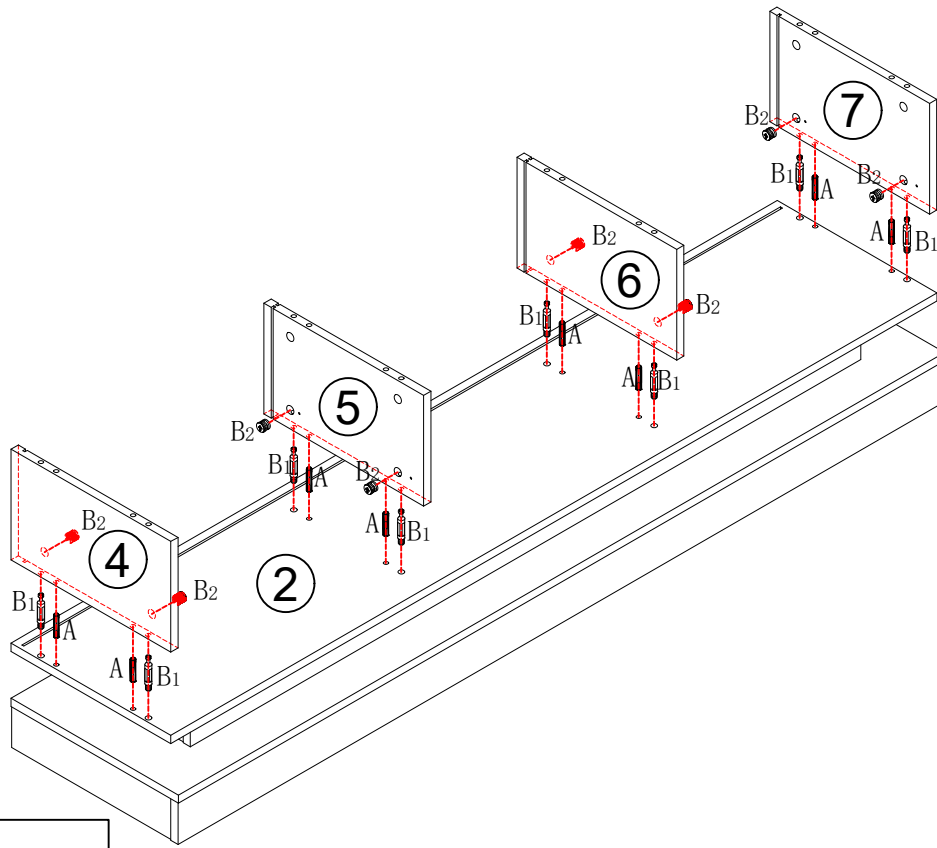

STEP 7





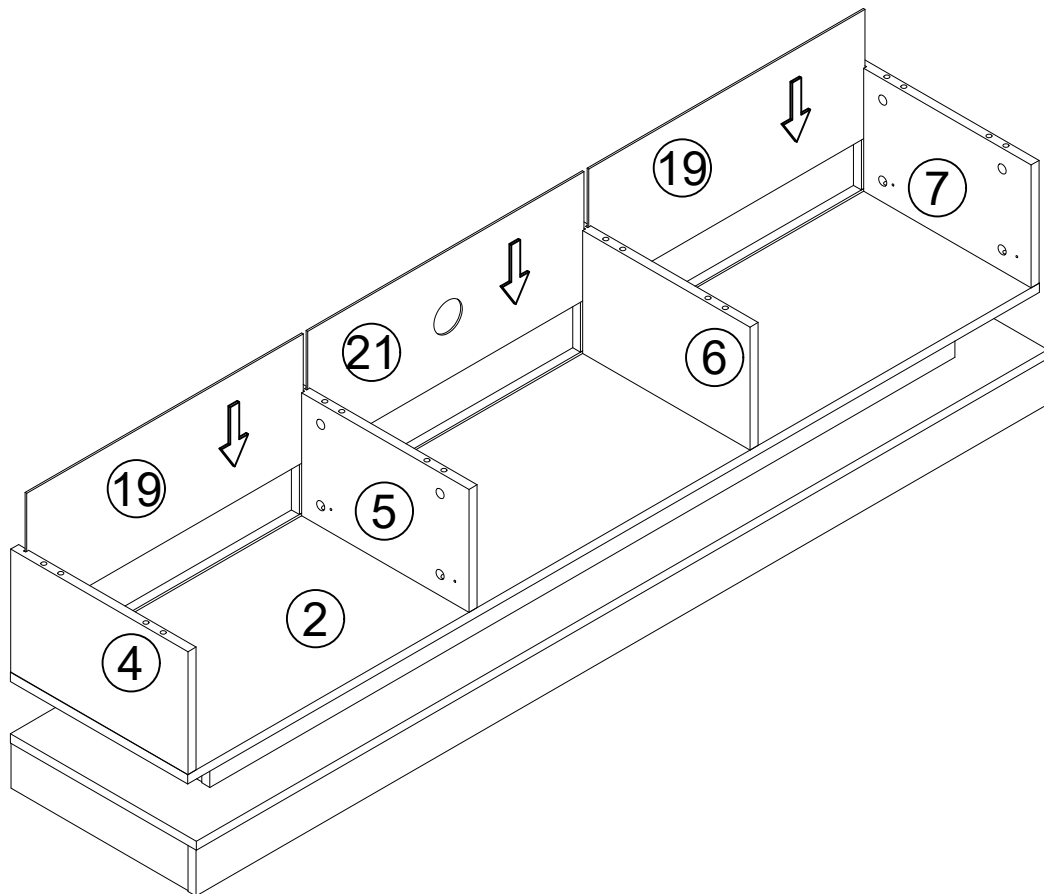

	Ax8pcs
	B ₁ x8pcs
	B ₂ x8pcs

STEP 8

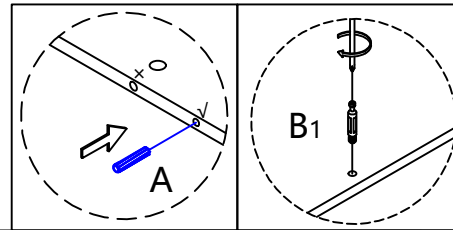
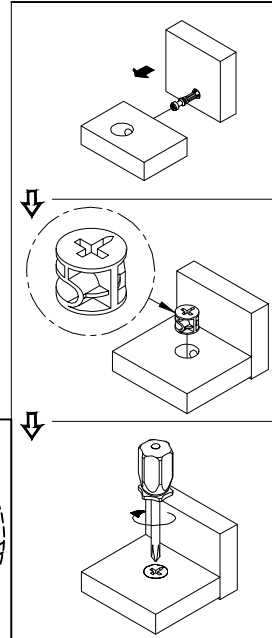
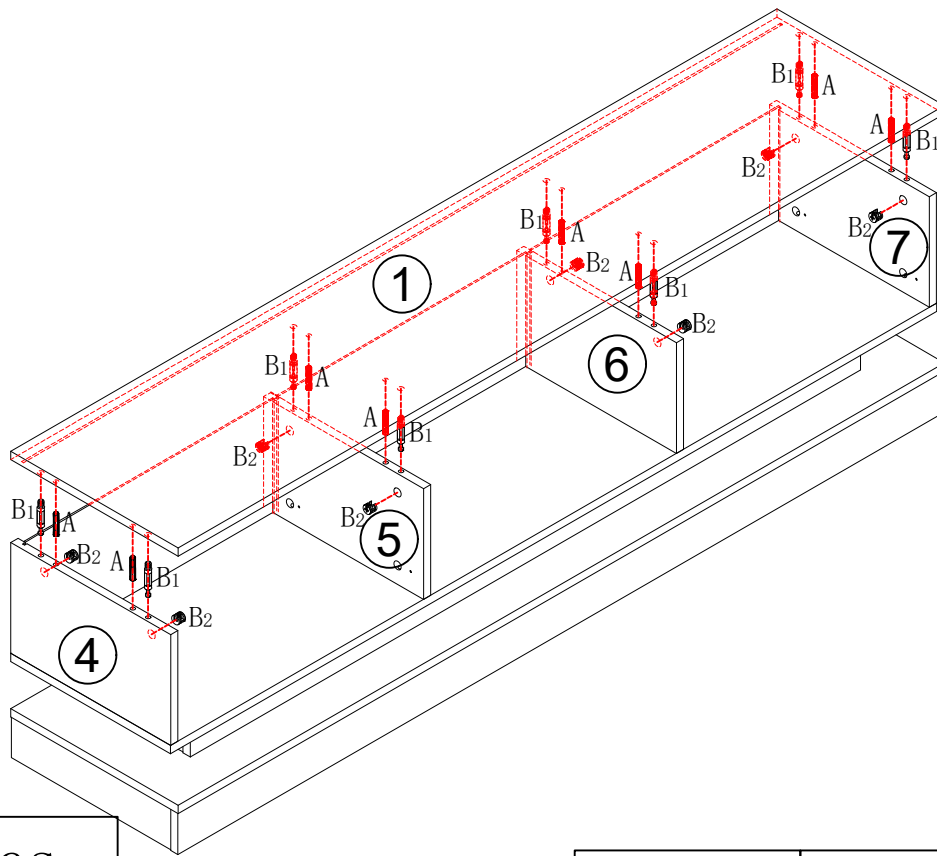



STEP 9



	Ax8pcs
	B ₁ x8pcs
	B ₂ x8pcs

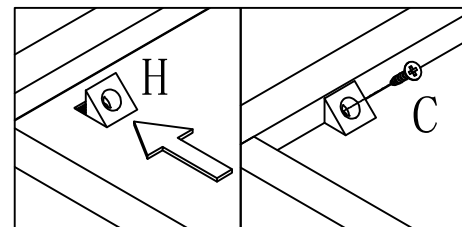
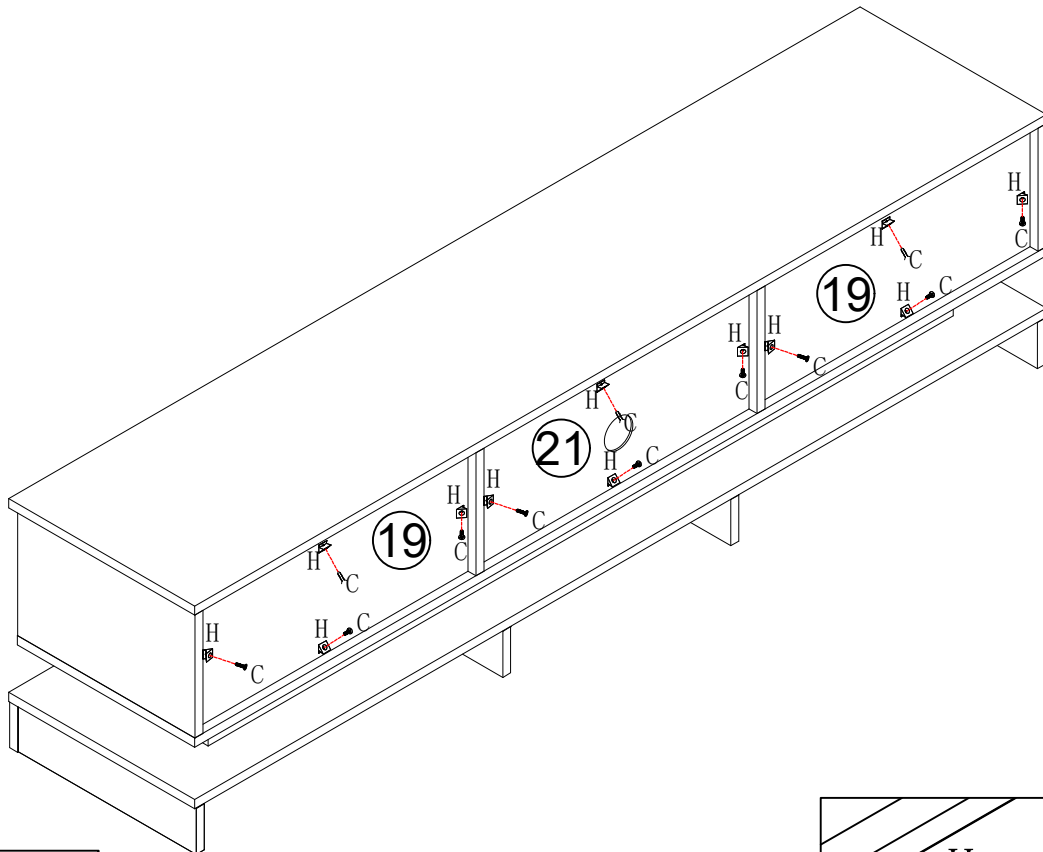

STEP 10

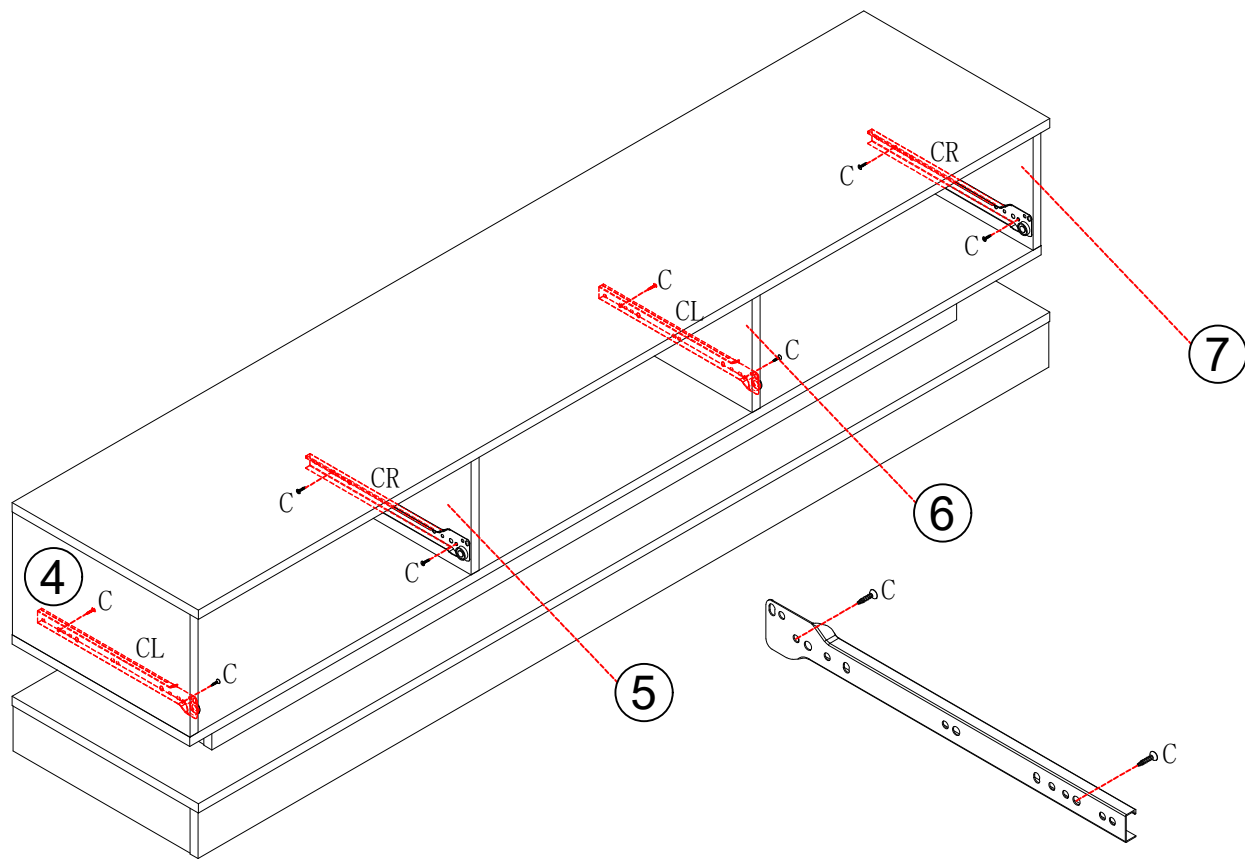

	Cx12pcs
	Hx12pcs

STEP 11

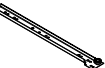

	Cx8pcs		
	CLx2pcs		CRx2pcs

STEP 12

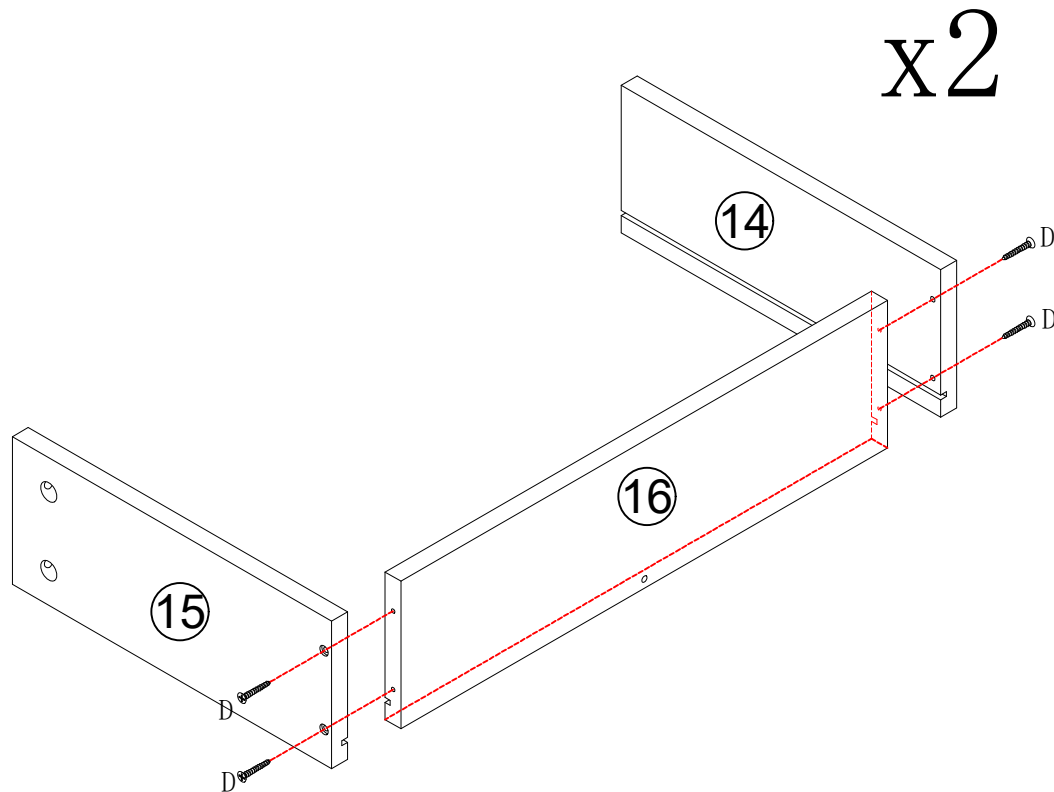

	Dx8pcs
--	--------

STEP 13

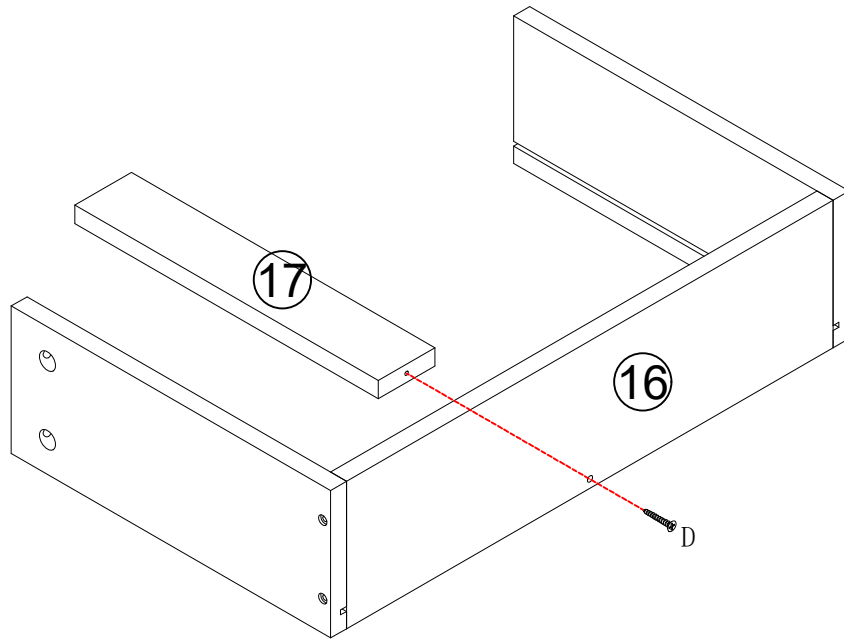

x2

	Dx2pcs
--	--------

STEP 14

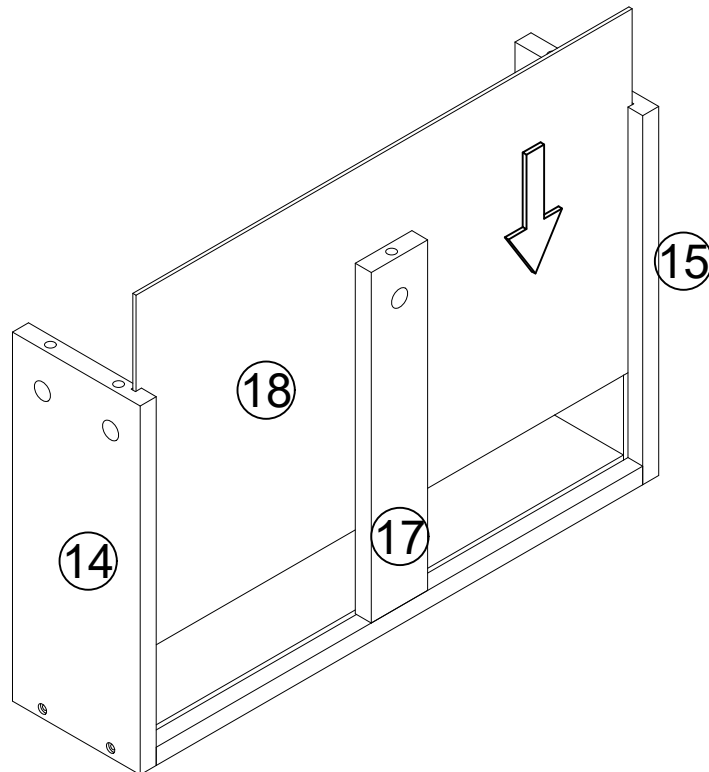

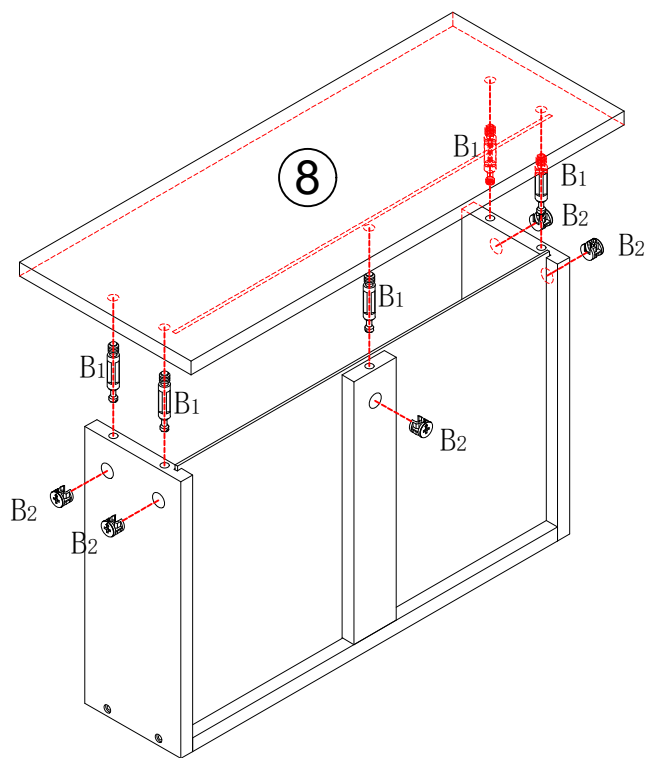

x2

STEP 15

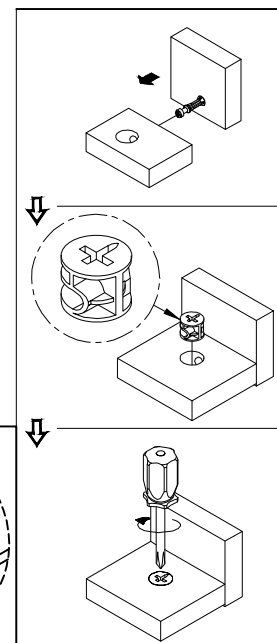

x2





	B ₁ x10pcs
	B ₂ x10pcs

STEP 16

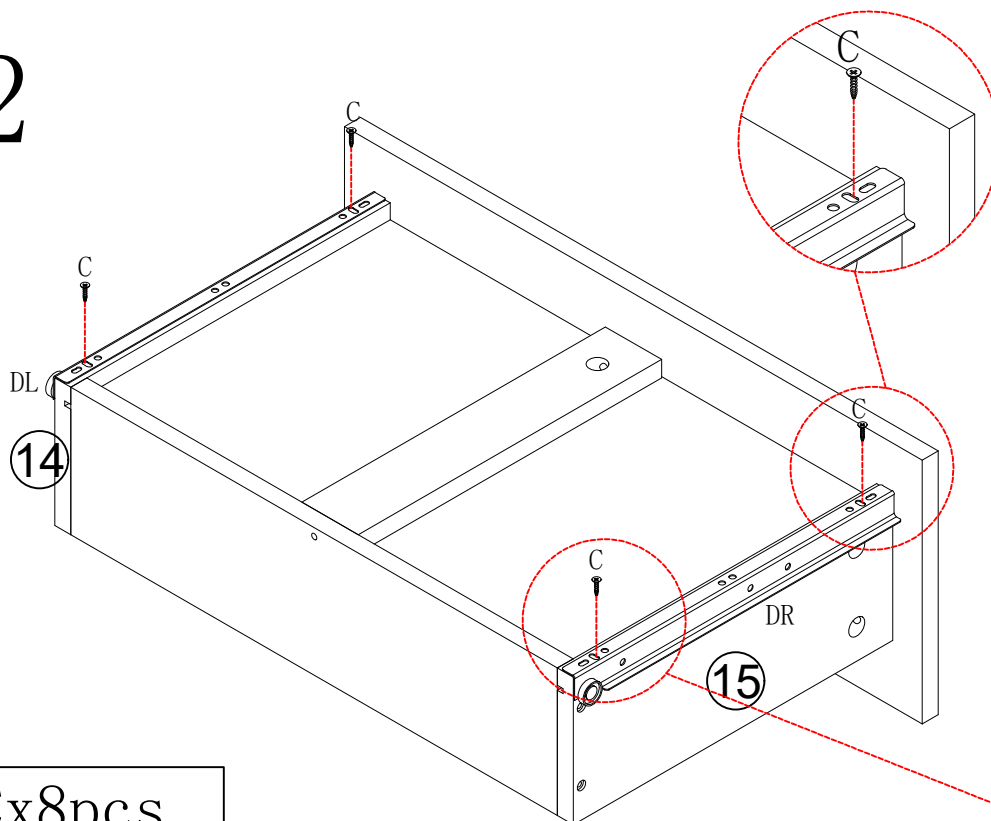
x2



	Cx8pcs
	DLx2pcs
	DRx2pcs

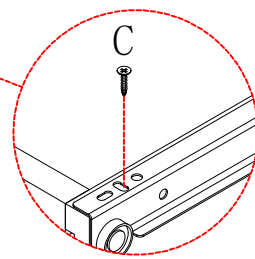



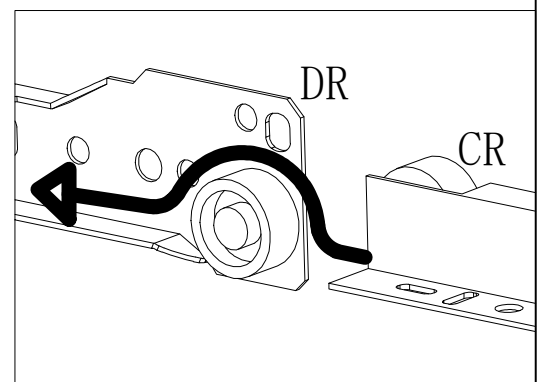
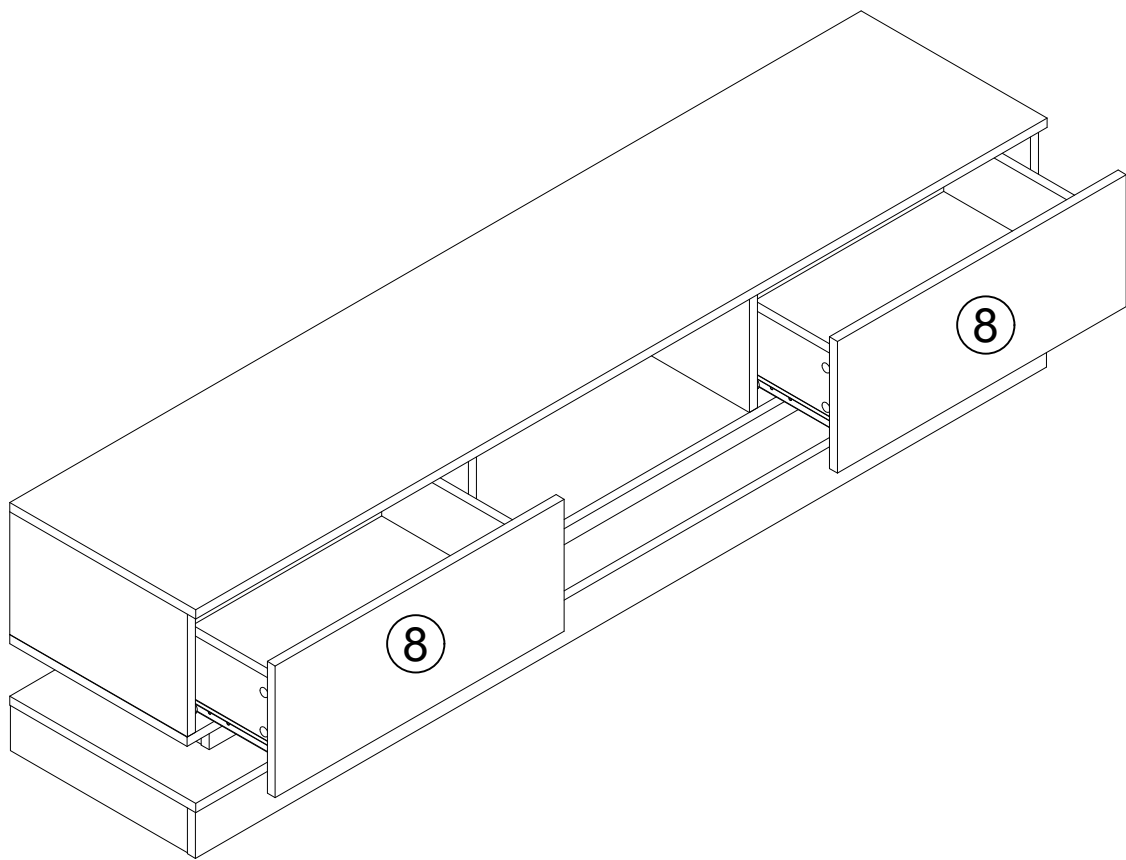

STEP 17

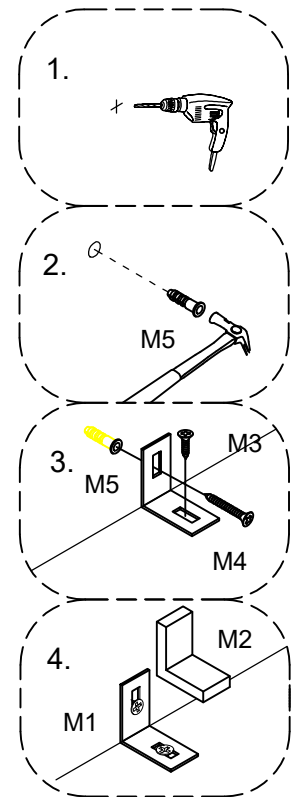
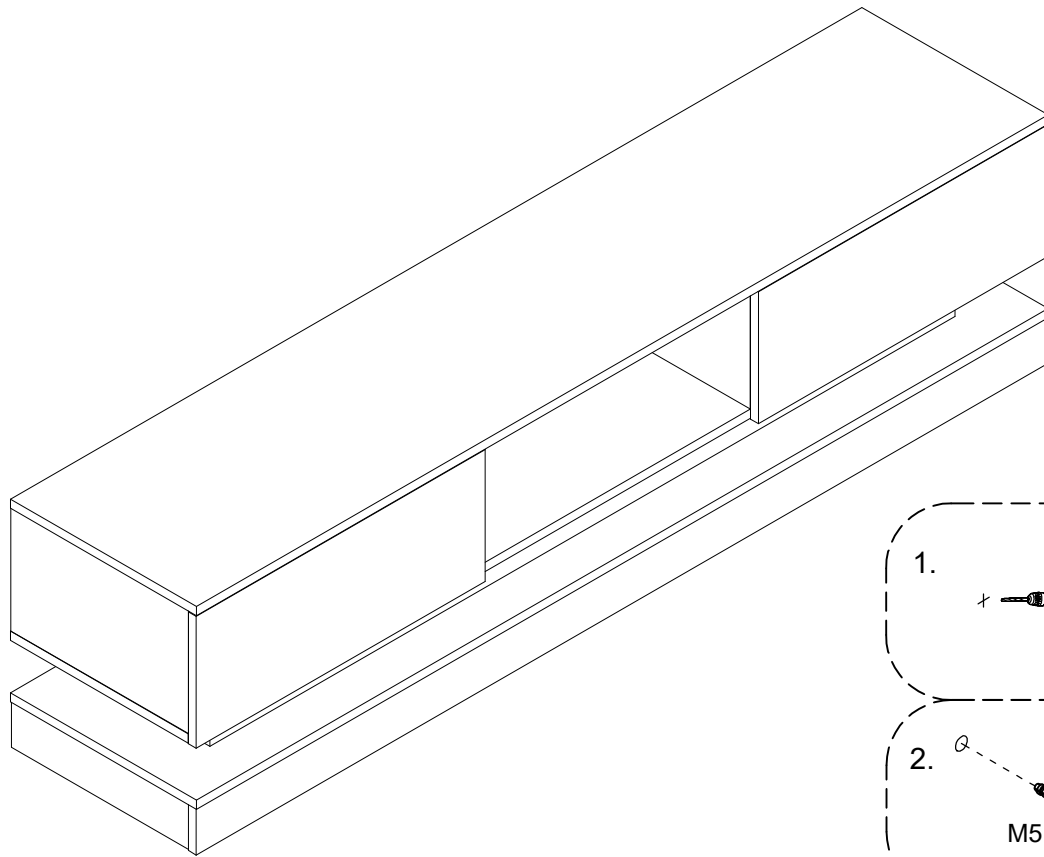

STEP 18



	M1x2pcs
	M2x2pcs
	M3x2pcs
	M4x2pcs
	M5x2pcs

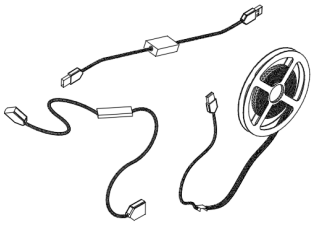

Anleitung zur Verwendung des LED-Controllers
Instructions for use of LED controller



iOS- und Android-Systeme können die App durch Scannen des QR-Codes herunterladen. Öffnen Sie den Browser oder ein anderes Tool mit der Funktion „QR-Code scannen“ und scannen Sie den QR-Code wie folgt:

iOS and android systems can download the app by scanning the QR code. Open the browser or other tools with "scan QR code" function, scan the QR code as below:

App-Download

QR-Code scannen
scan the QR code



App-Bedienung
App operation

Klicken Sie auf das App-Symbol „duoCo Strip“ und rufen Sie die App-Seite auf.
Click “duoCo Strip” app icon, and enter the app page



Wenn nach dem Aufrufen der App-Oberfläche Bluetooth nicht aktiviert ist und es eine Anwendung gibt, die die Bluetooth-Funktion des Geräts aktivieren möchte, klicken Sie auf Zulassen.

After entering the App interface, if Bluetooth is not turned on and there is an application that wants to turn on the Bluetooth function of the device, click Allow.

STEP 19

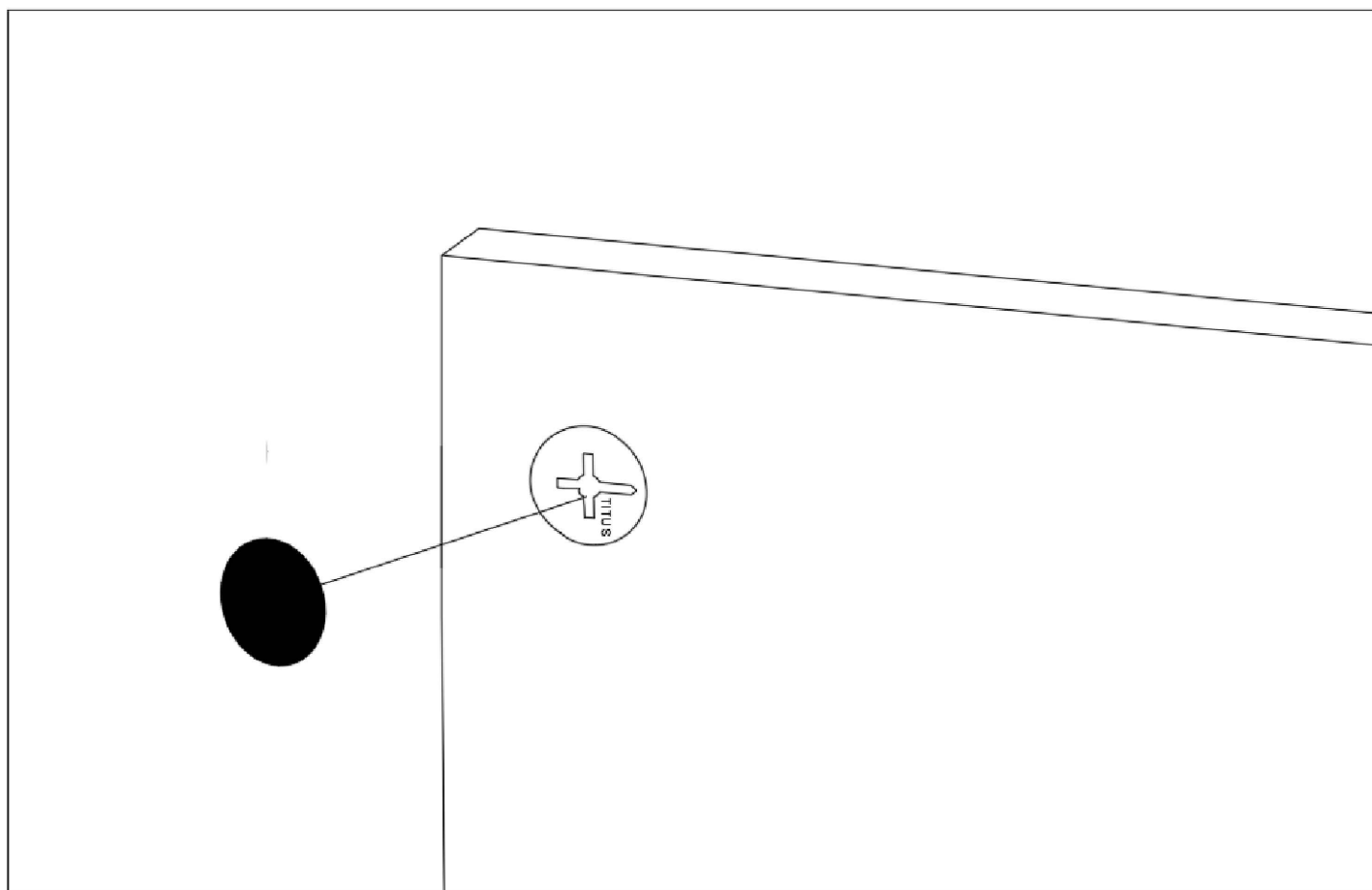

UK: After installing the product, stick the number K on the perforated position

FR: Une fois le produit installé, collez le numéro K à l'endroit où il y a des trous

DE: Nach der Installation des Produkts kleben Sie die Nummer K auf die perforierte Position



Kx30pcs

Verification of Compliance

Verification No.:	TMC210319126-E
Name and address of Applicant:	Shenzhen CWG Technology Co., Ltd 5 / F, No.264 Baoshi East Road, Shiyan street, Bao'an District, Shenzhen,China 518108
Name and address of Manufacturer	Shenzhen CWG Technology Co., Ltd 5 / F, No.264 Baoshi East Road, Shiyan street, Bao'an District, Shenzhen,China 518108
Product name:	LED Strip
Rated:	DC12V
Product model(s):	CWG-5050RGB-60D-12V , additional models reference attachment
Product trademark:	创唯光

This verification confirms that the product meets the requirements of the following standard. The conformity was demonstrated based on following standard(s) listed by European Commission as harmonized with EMC Directive 2014/30/EU.

EN IEC 55015:2019+A11:2020
IEC 61547:2020

The verification has been carried out in accordance with individual rules and conditions agreed with the applicant. Evaluation has been carried out in accordance with:

Test report(s) No.:	TMC210319126-E
Test conducted by:	TMC Testing Services (Shenzhen) Co., Ltd.
Verification issue date:	March 26, 2021

Notes:

This verification refers to the above mentioned product and its conformity in regards of above mentioned standard(s) was proven on test sample.

This verification does not imply meeting all essential requirements, assessment of the series-production or any other restricted Notified Bodies conformity assessment procedure appropriate for the product.

This verification holder shall use this verification in connection to verification of conformity and technical data relevant for the product the verification was issued.

TMC Testing Services (Shenzhen) Co., Ltd.

t:86-755-86642861 cert@tmc-lab.com www.tmc-lab.com

1st Floor, Block A1, Zone A, Xinshidai Gongrong Industrial Park, No. 2, Shihuan Road, Shiyan Street, Baoan District, Shenzhen, China



Lab Director
Lemon Rao



Attestation of Compliance

Declaration No.: TMC210319128-E

Name and address of Applicant: **Shenzhen CWG Technology Co., Ltd**
5 / F, No.264 Baoshi East Road, Shiyan street, Bao'an District, Shenzhen,China
518108

Name and address of Manufacturer: **Shenzhen CWG Technology Co., Ltd**
5 / F, No.264 Baoshi East Road, Shiyan street, Bao'an District, Shenzhen,China
518108

Product name: **LED Strip**

Rated: DC12V
CWG-5050RGB-60D-12V, CWG-5050RGB-30D-12V , CWG-5050RGB-18D-12V,
CWG-5050RGB-60D-24V, CWG-5050RGB-60D-5V, CWG-5050RGB-30D-5V,
CWG-5050RGB-18D-5V, CWG-5050-60D-12V, CWG-5050-30D-12V,
CWG-5050-60D-24V, CWG-HC5050RGB-60D-12V,
CWG-HC5050RGB-30D-12V, CWG-HC5050RGB-60D-24V,
CWG-HC5050-60D-12V, CWG-HC5050-30D-12V, CWG-HC5050-60D-24V,
CWG-HC5050RGB-30D-5V, CWG-HC5050RGB-60D-5V,
CWG-HC5050RGB-144D-5V, CWG-2835-60D-12V, CWG-2835-120D-12V,
CWG-2835-60D-24V, CWG-2835-120D-24V, CWG-2835-60D-5V,
CWG-2835-120D-5V

Product model(s):

Product trademark: 创唯光

This Attestation of Compliance confirms that the product meets the requirements of the following standard.

BS EN IEC 55015:2019+A11:2020

IEC 61547:2020

The Attestation of Compliance has been carried out in accordance with individual rules and conditions agreed with the applicant. Evaluation has been carried out in accordance with:

Test report(s) No.: TMC210319128-E

Test conducted by: TMC Testing Services (Shenzhen) Co., Ltd.

Declaration issue date: March 26, 2021

Notes:

This Attestation of Compliance is issued according to the Great Britain legislation Electromagnetic Compatibility Regulations 2016 It confirms that the listed products complies with all essential requirements of the Regulations and applies only to the sample and its technical documentation to TMC Testing Services (Shenzhen) Co., Ltd. for testing.

After preparation of the necessary technical documentation (which must be kept for up to 10 years after the product is placed on the GB market) as well as the UK Declaration of Conformity, the required UKCA marking can be affixed on the product. Other relevant Regulations have to be observed.

TMC Testing Services (Shenzhen) Co., Ltd.

t:86-755-86642861 cert@tmc-lab.com www.tmc-lab.com

1st Floor, Block A1, Zone A, Xinshidai Gongrong Industrial Park, No. 2, Shihuan Road, Shiyan Street, Baoan District, Shenzhen, China



**UK
CA**