

## 5 PIECE OUTDOOR SECTIONAL SOFA

There is no need to return your furniture set.  
Contact us for after-sale service!

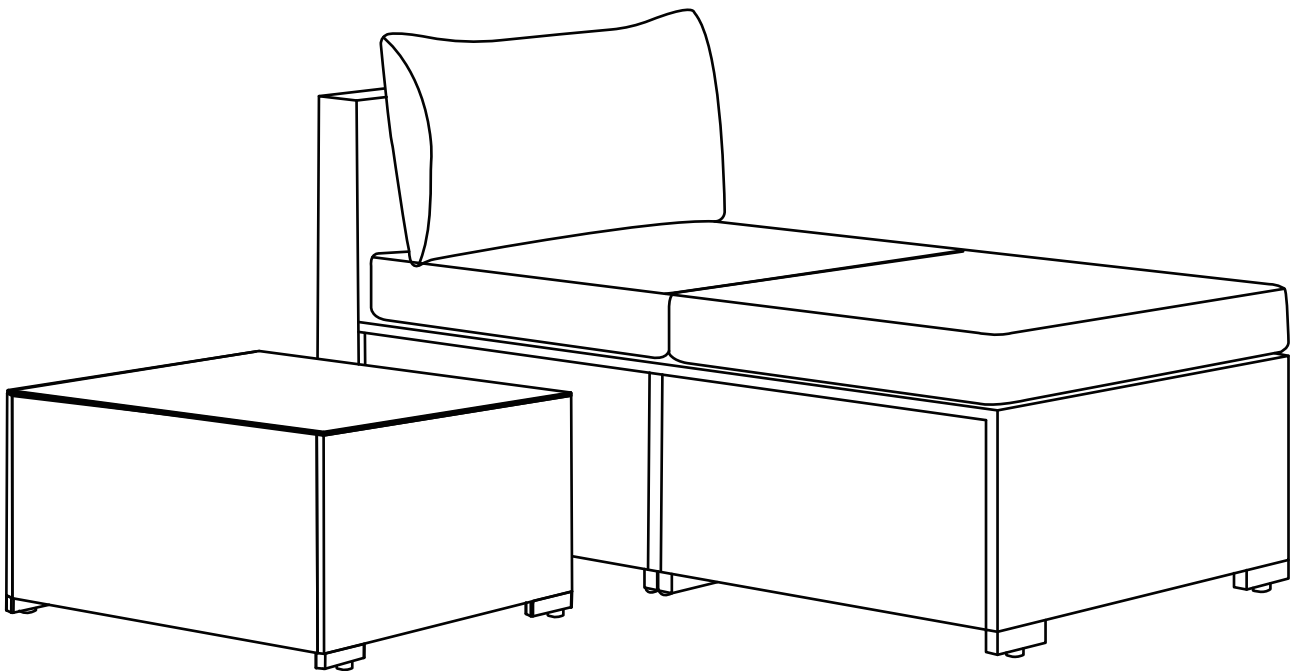

**After-sales mailbox:**  
**[Patiofurniture Serviceteam@outlook.com](mailto:Patiofurniture Serviceteam@outlook.com)**

# NOTICE

---

**Please keep these instructions for future reference.**

**Dear Customer**

- Thank you for your purchase. When you receive the product, please make sure that all the parts are intact. Then follow the entire installation instructions to install!
- There is an installation video on the product page, you can open the product page to view it or contact customer service to receive it.

- A . The outer box is damaged
- B . The product is damaged / bent / cracked while you open the box
- C . The parts / accessories / assembly tools are missing
- D . The instructions are not clear and can not be referred
- E . The product has functional problems
- F . Other aspects that you are not satisfied with

Please feel free to contact us for help. Our after-sales team service

([Patiofurniture Serviceteam@outlook.com](mailto:Patiofurniture Serviceteam@outlook.com)) will reply within 24 hours and will do our best to resolve the problem for you.



# PART LIST

## ARMLESS SOFA

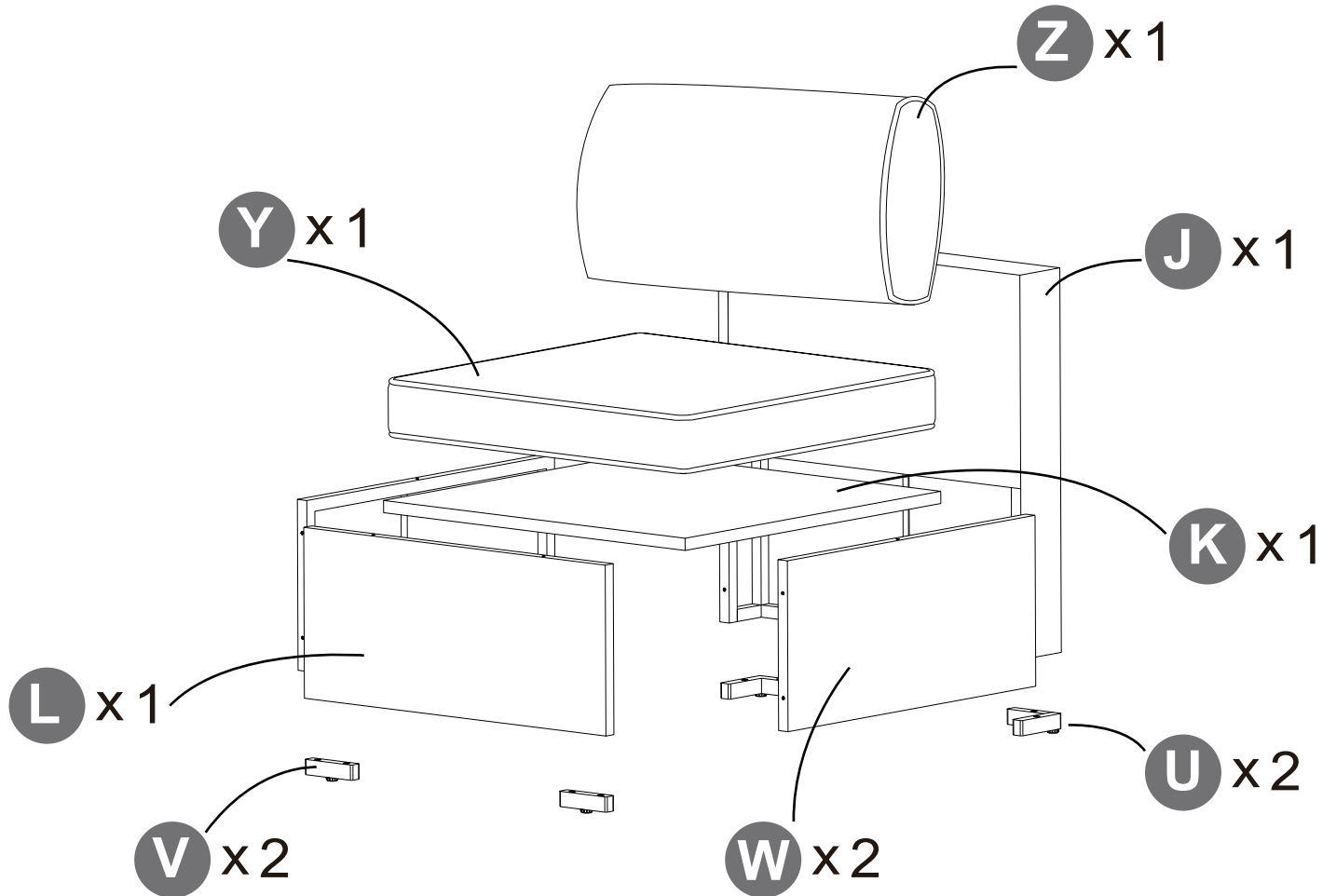

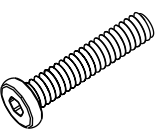
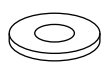
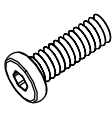
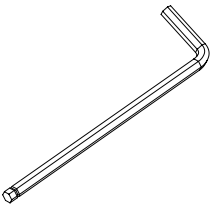

<p><b>1</b></p>  <p>M6*35MM</p> <p>x 14</p>	<p><b>2</b></p>  <p>Gasket</p> <p>x 14</p>	<p><b>3</b></p>  <p>M6*25MM</p> <p>x 8</p>	<p><b>4</b></p>  <p>x 1</p>
--	---	--	--

# PART LIST

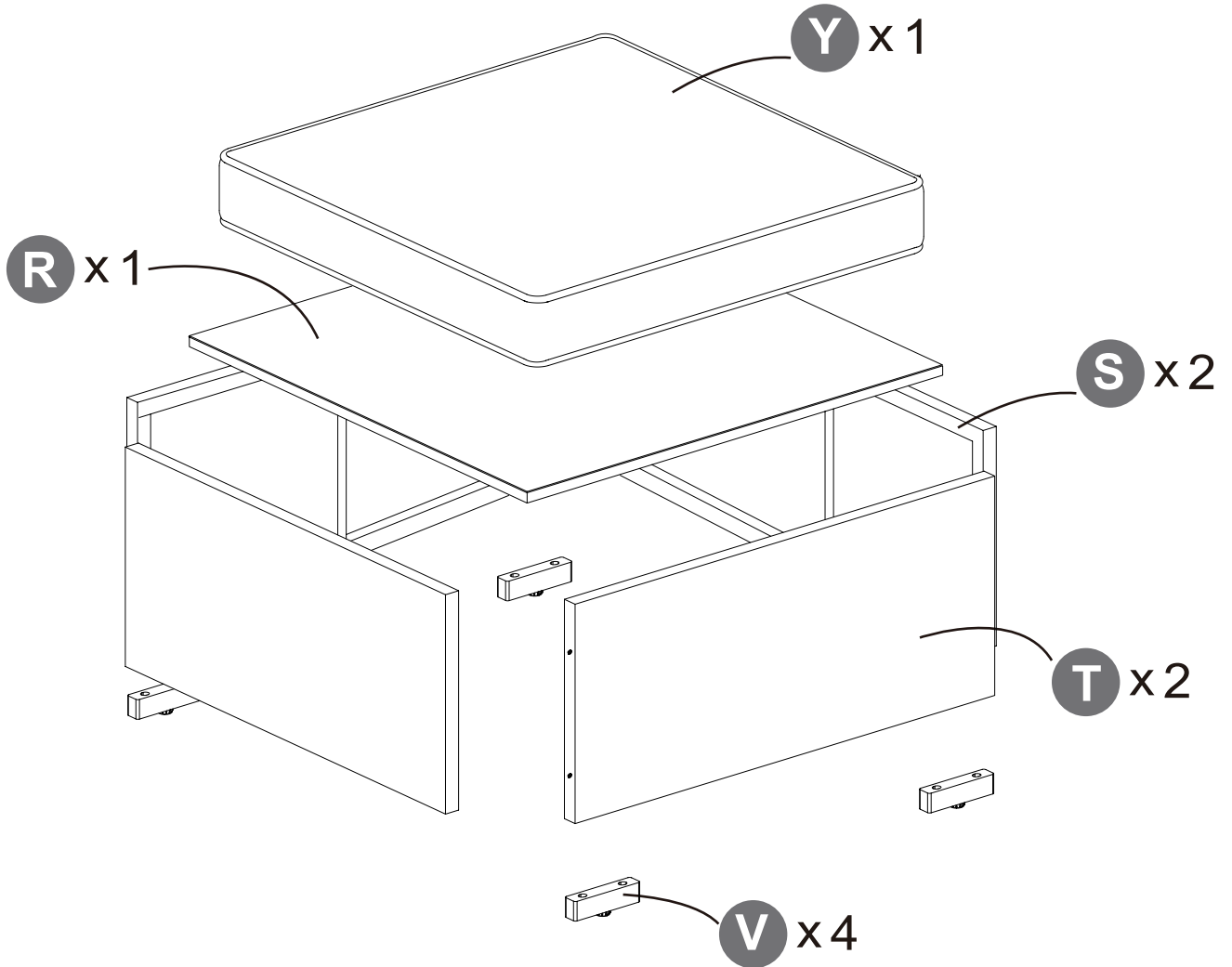
## OTTOMAN

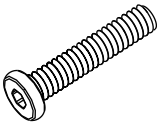

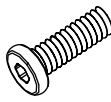

<p>1</p>  <p>M6*35MM</p> <p>x12</p>	<p>2</p>  <p>Gasket</p> <p>x12</p>	<p>3</p>  <p>M6*25MM</p> <p>x 8</p>
--	---	--

# PART LIST

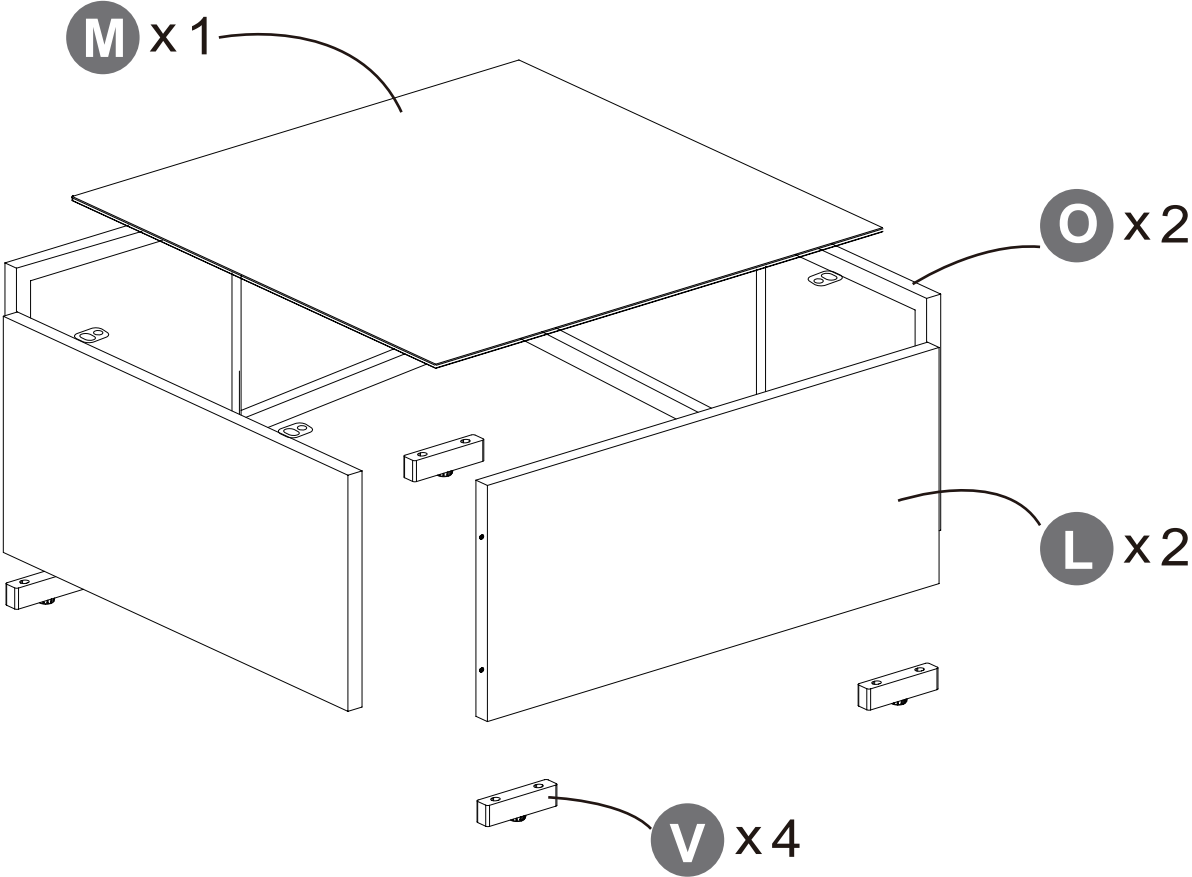
## SIDE TABLE

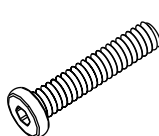

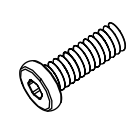
<p>1</p>  <p>M6*35MM</p> <p>x 8</p>	<p>2</p>  <p>Gasket</p> <p>x 8</p>	<p>3</p>  <p>M6*25MM</p> <p>x 8</p>
--	---	--

# STEP

## 1 ARMLESS SOFA INSTALLATION

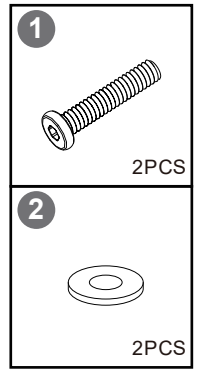
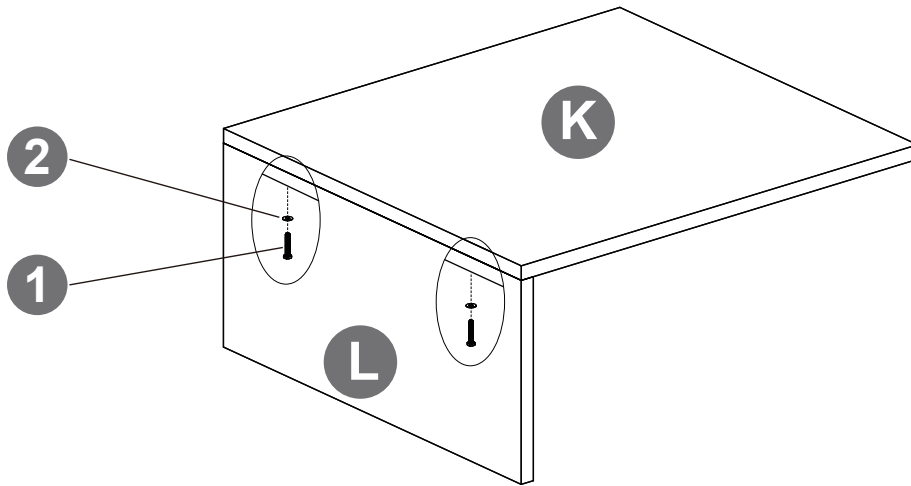

## 2

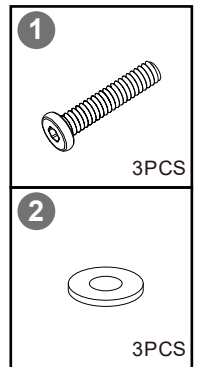
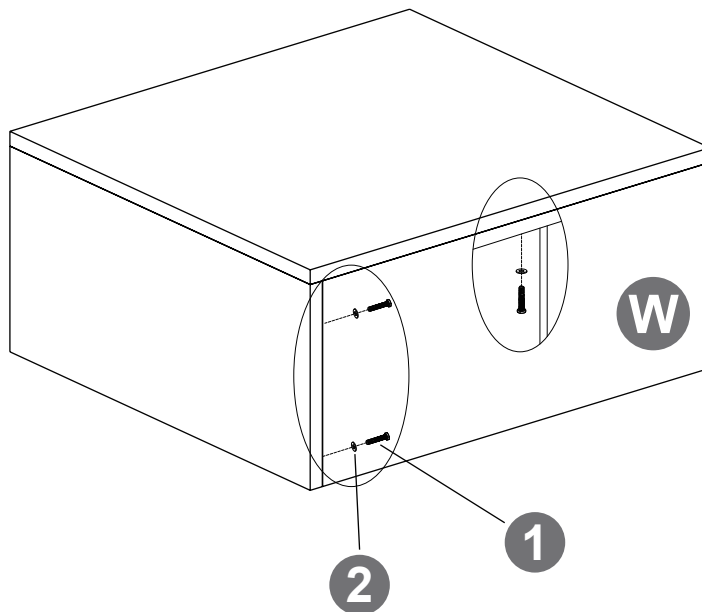

# STEP

3

## ARMLESS SOFA INSTALLATION

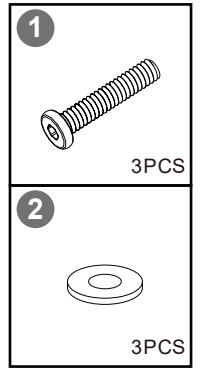
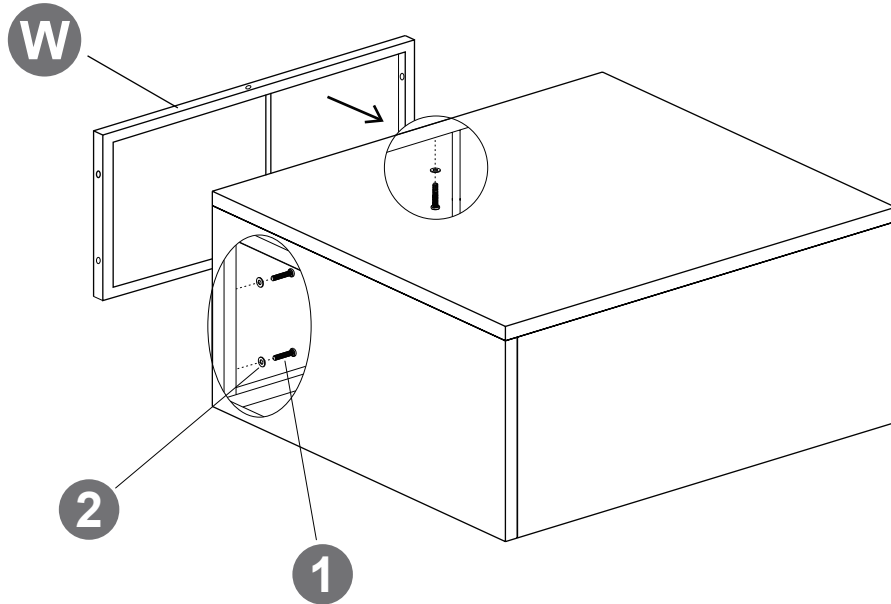

4

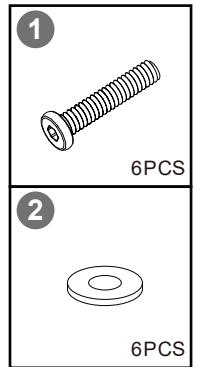
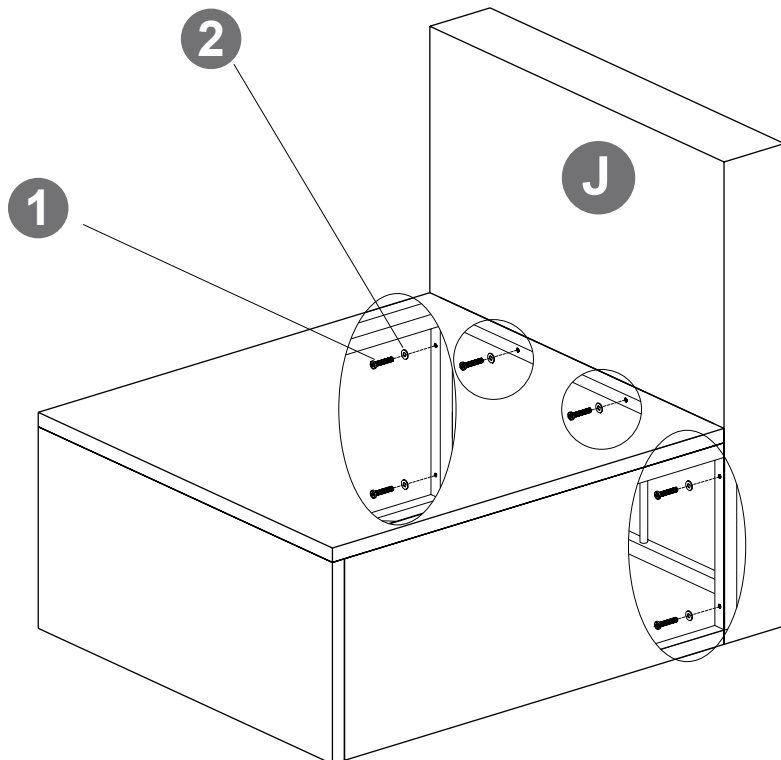

6

# STEP

5

## ARMLESS SOFA INSTALLATION

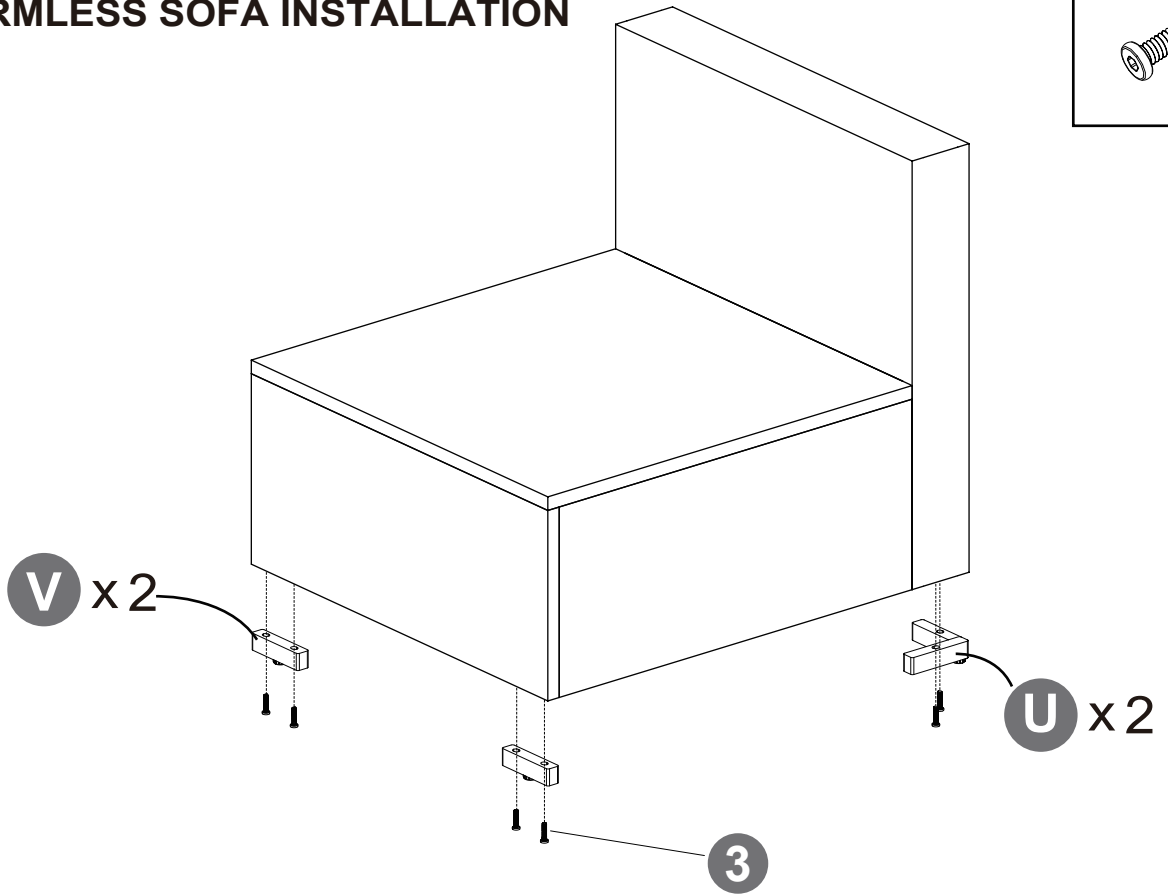
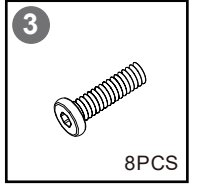

6

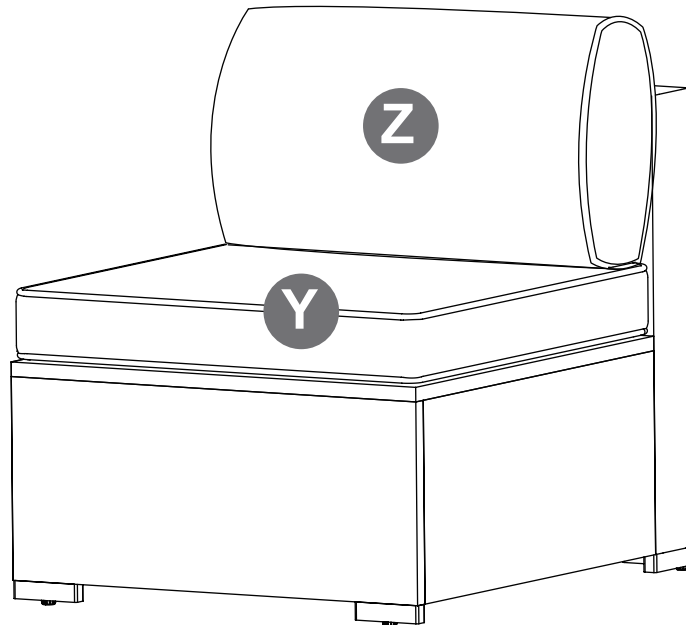

# STEP

7

## OTTOMAN INSTALLATION

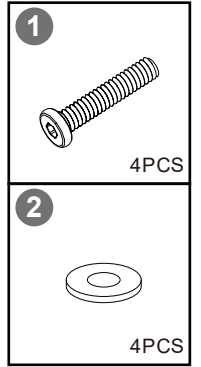
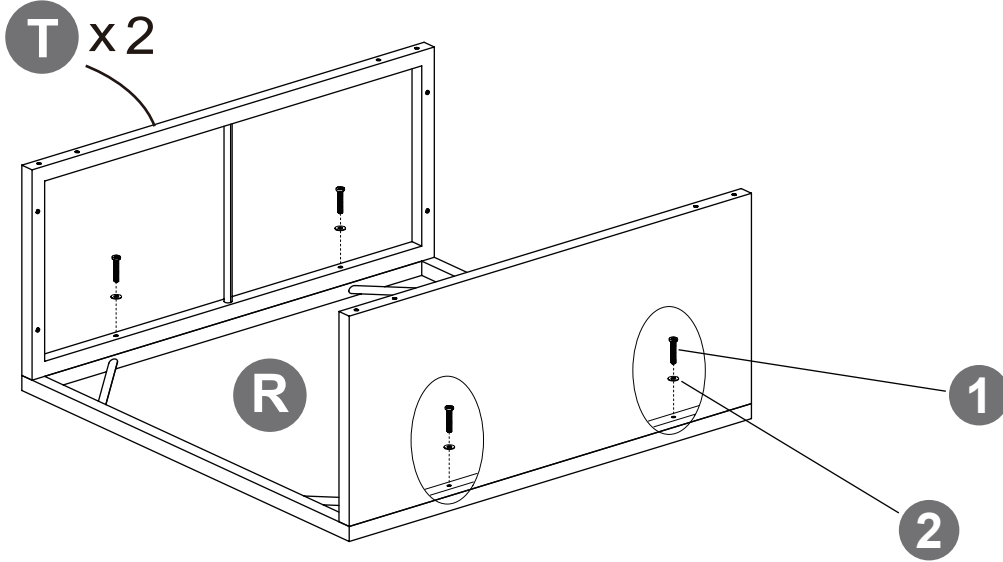

8

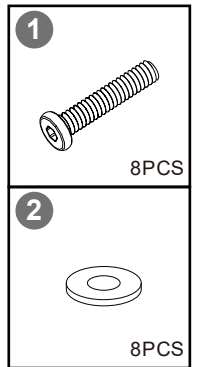
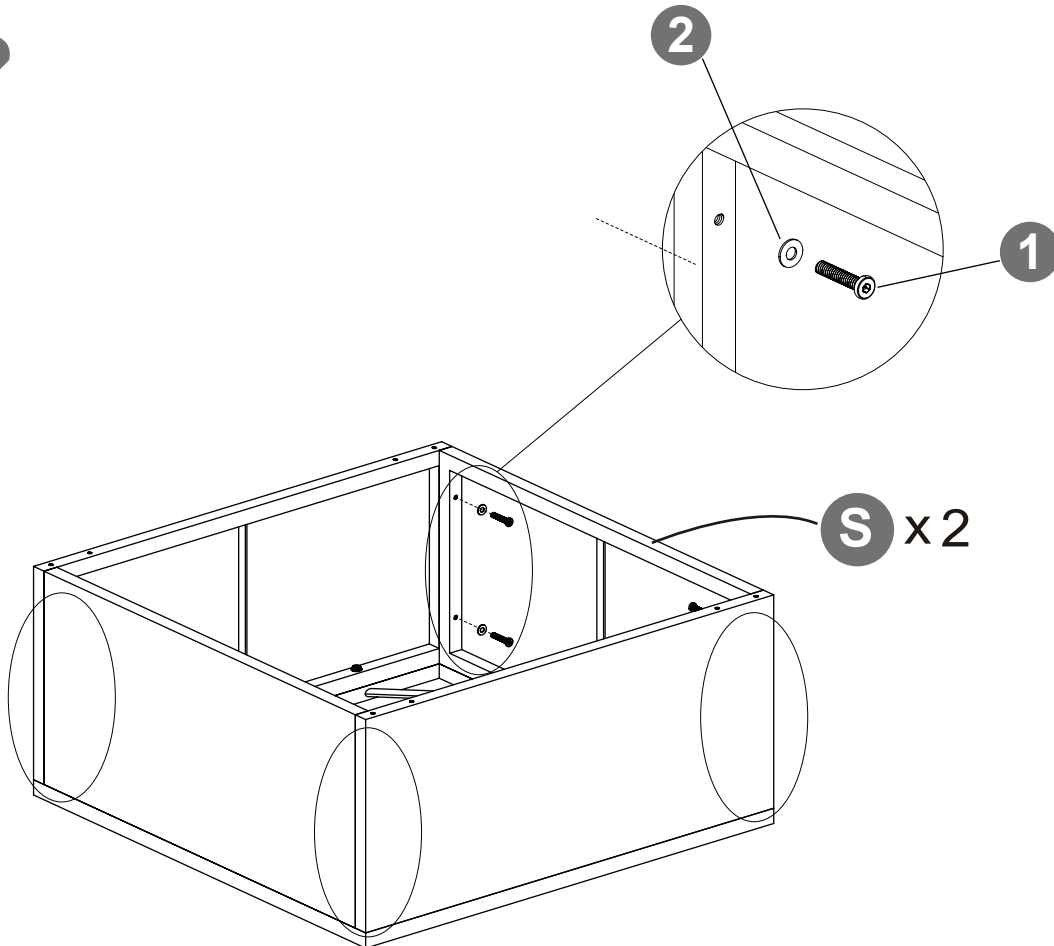

# STEP

9

## OTTOMAN INSTALLATION

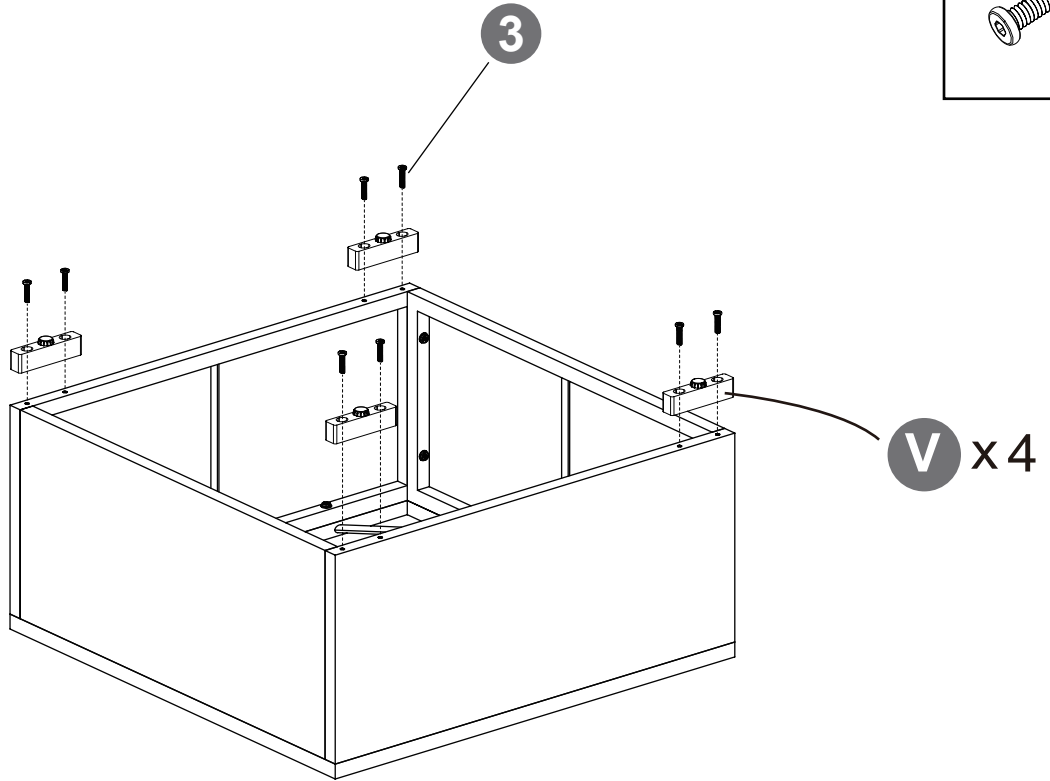
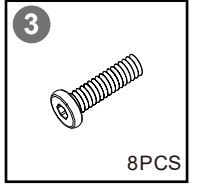

10

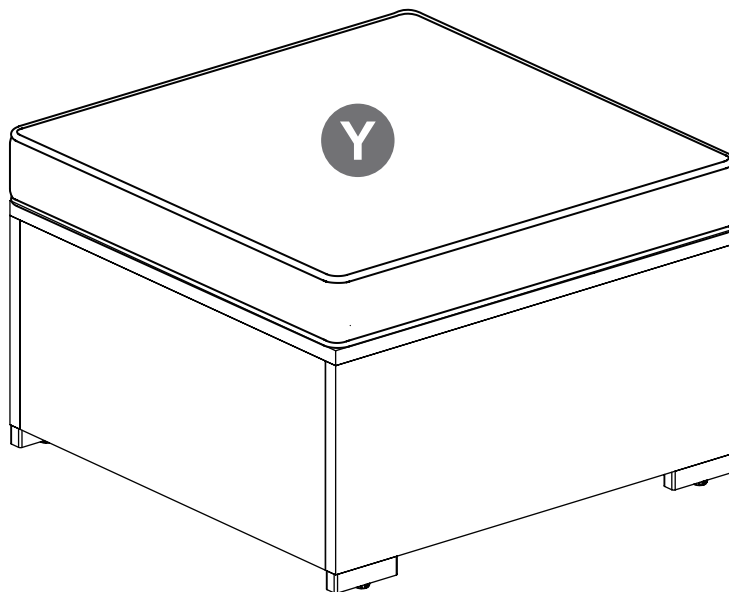

9

# STEP

11

## TABLE INSTALLATION

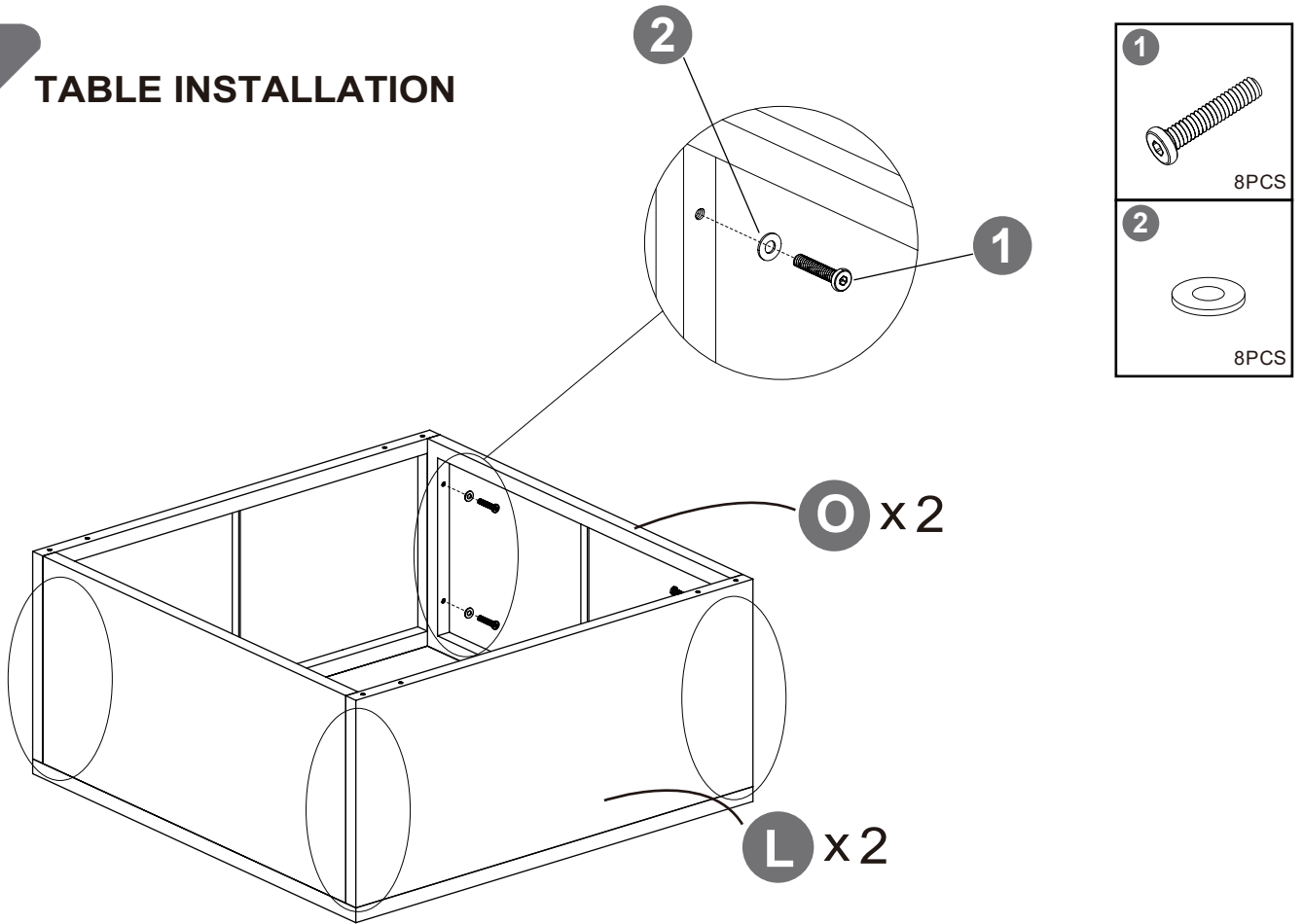

12

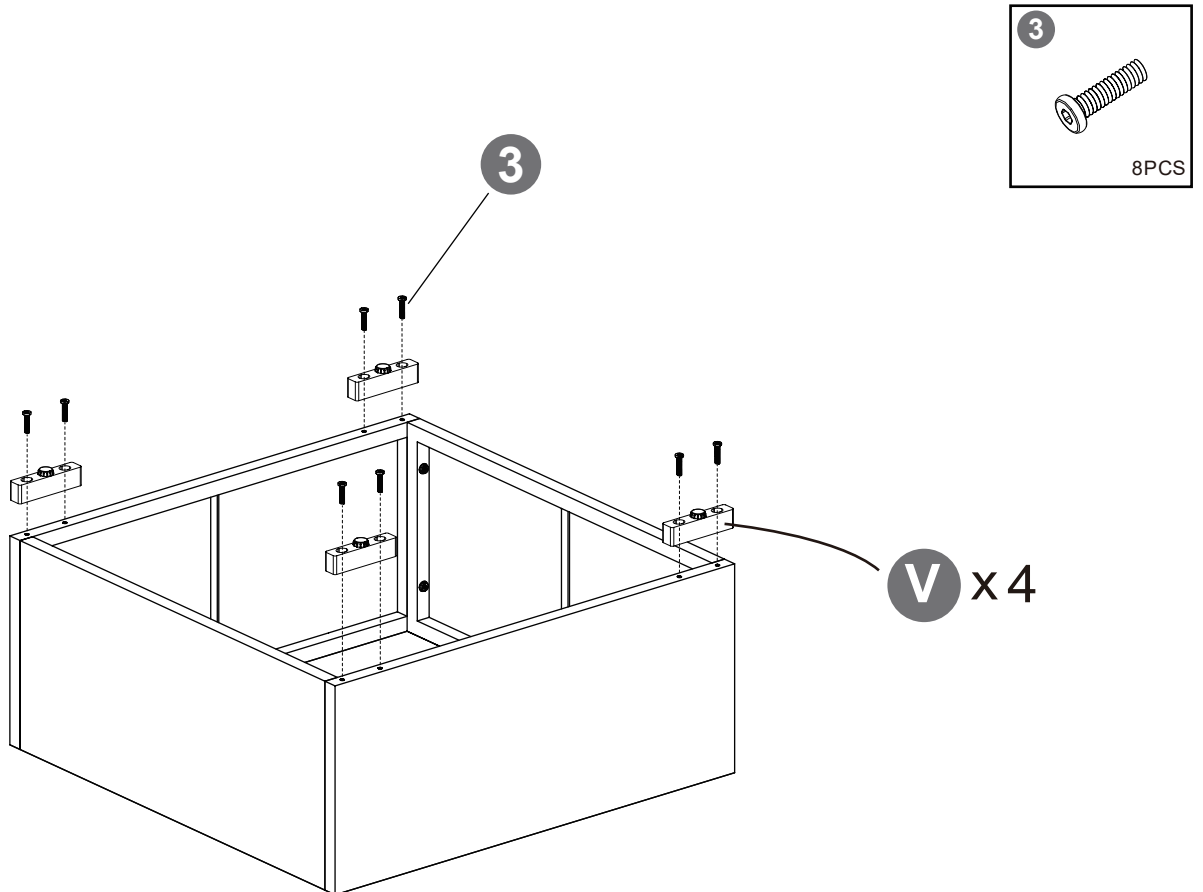

# STEP

13

TABLE INSTALLATION

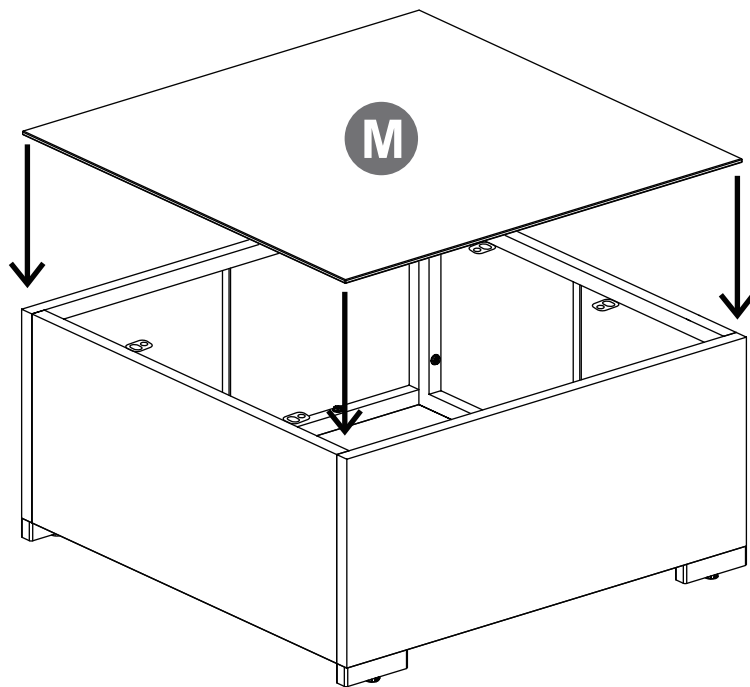

14

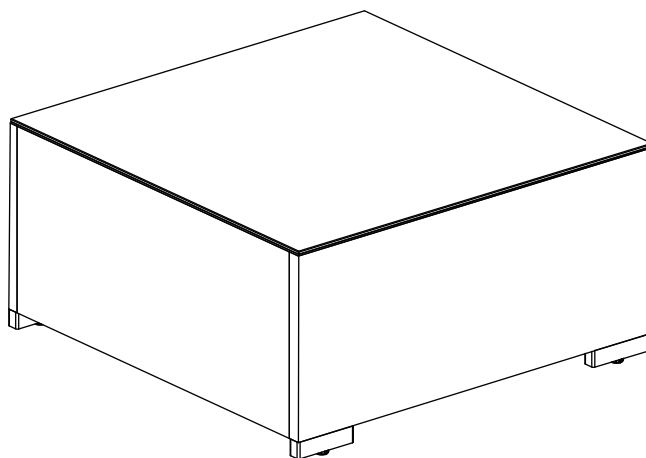

## AFTER-SALE SERVICE

If you have any suggestions for our products or find that the products have quality problems, please contact us first, our after-sales team will reply you within 24 hours, and we will do our best to give you solutions until you are satisfied.

### Guaranteed Customer Service

Your shopping experience is very important to us!  
Feel unsatisfied? **Contact us!**  
Have any questions? **Contact us!**

Wanna Share how wonderful our smart promakes your home?  
Share your pictures with us.  
Any suggestions? **Contact us!**  
We gotcha back!



[Patiofurniture Serviceteam@outlook.com](mailto:Patiofurniture Serviceteam@outlook.com)

