

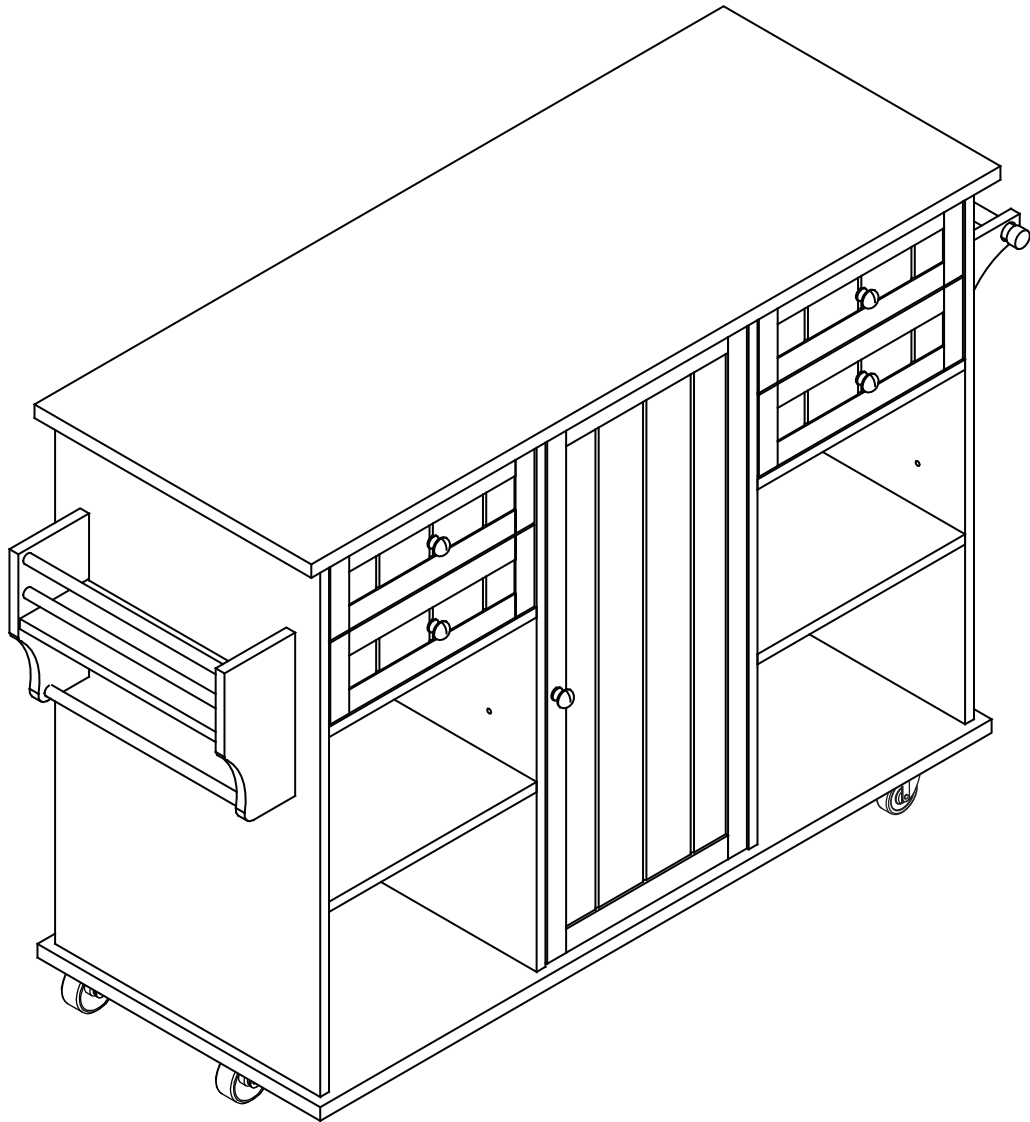

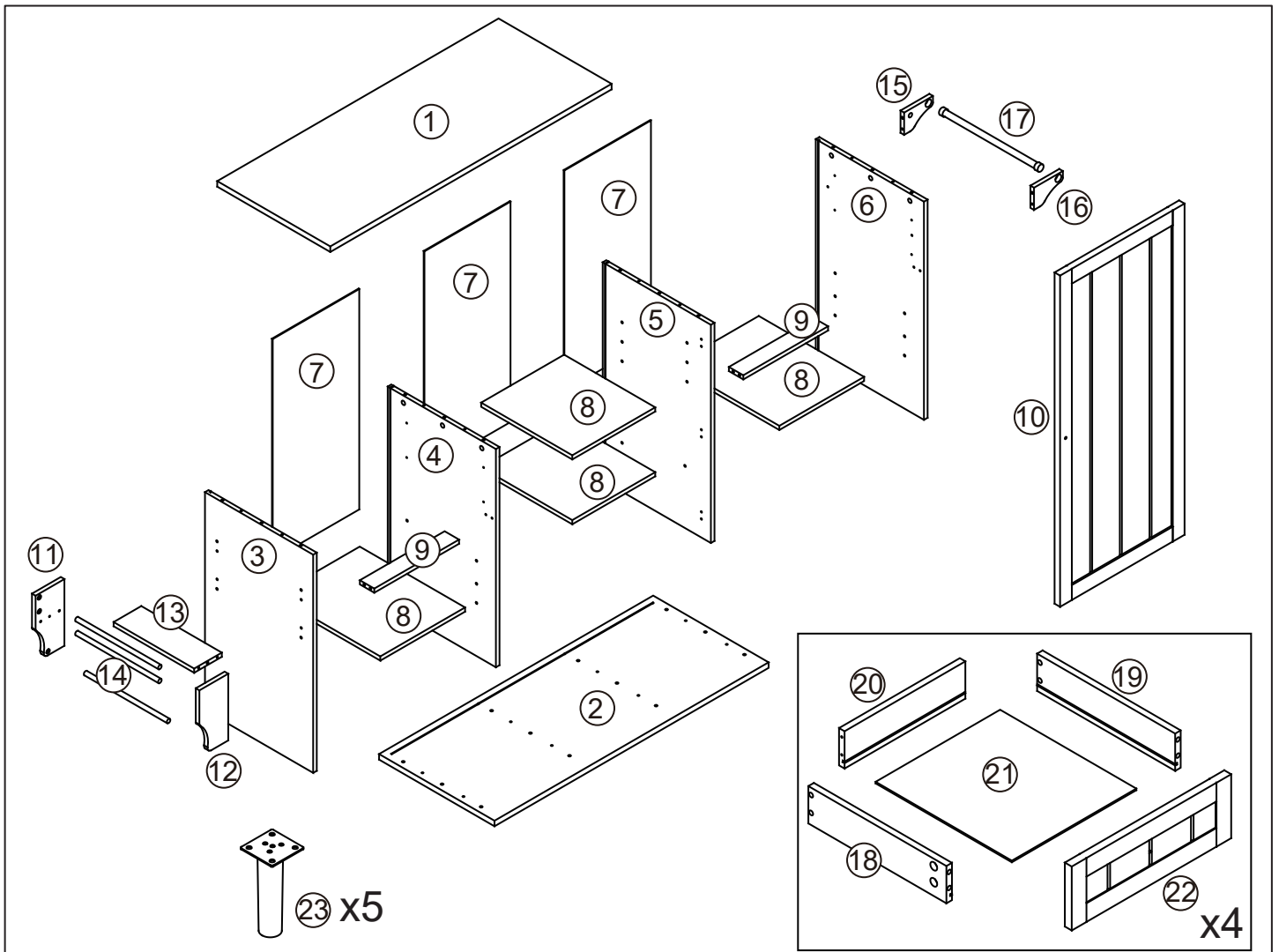

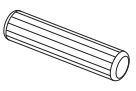

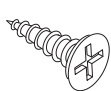





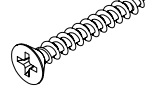

WF296868

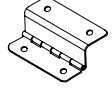
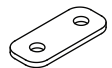

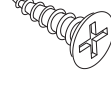
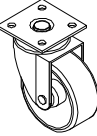
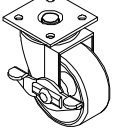
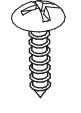

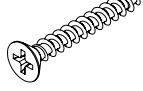
A  x26	B 3x12mm  x46	C  x38	D  x38	E  x5	F 4x35mm  x20
G  x3	H  x2	I  x2	J 5x15mm  x16	K  x3	L  x1
M  x1	N 3x14mm  x8	O  x1	P  x4	Q 5x14mm  x20	R  x5
S  x38	T 4x50mm  x12	U  x1	V CL CR DL DR  x4 x4 x4 x4	W  x12	

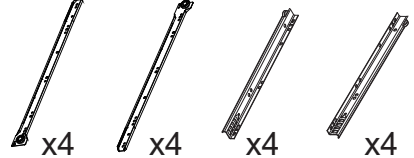
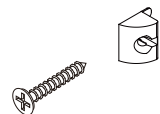
# Using Camlocks

## Step 1

Connect the male camlock as directed in the assembly instructions using a screwdriver.

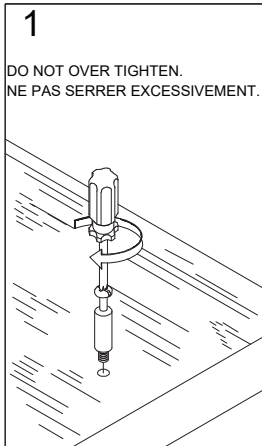

## Step 2

Push the male camlock into the entry hole.

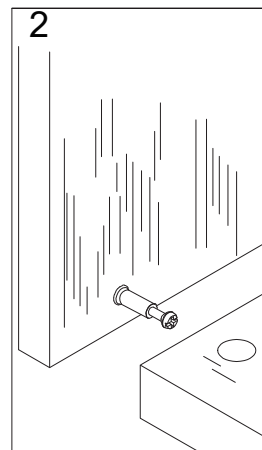

## Step 3

Insert the female camlock as shown in the instruction.

Note: ensure that the arrow on the top of the camlock points towards the entry hole for the male camlock.

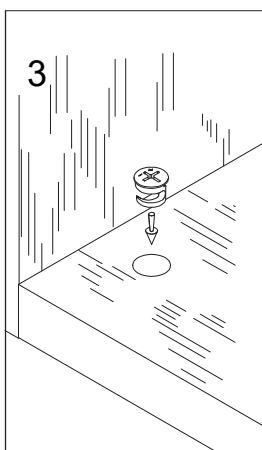

## Step 4

Turn the female camlock clockwise with a screwdriver.

You should feel a click when the camlock is locked in place.

The joint is now secure.

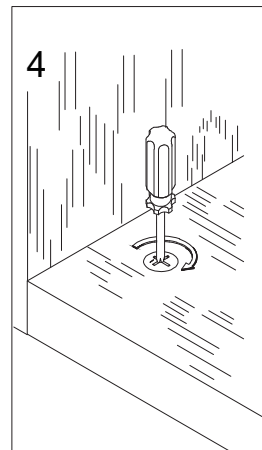

# Step 1

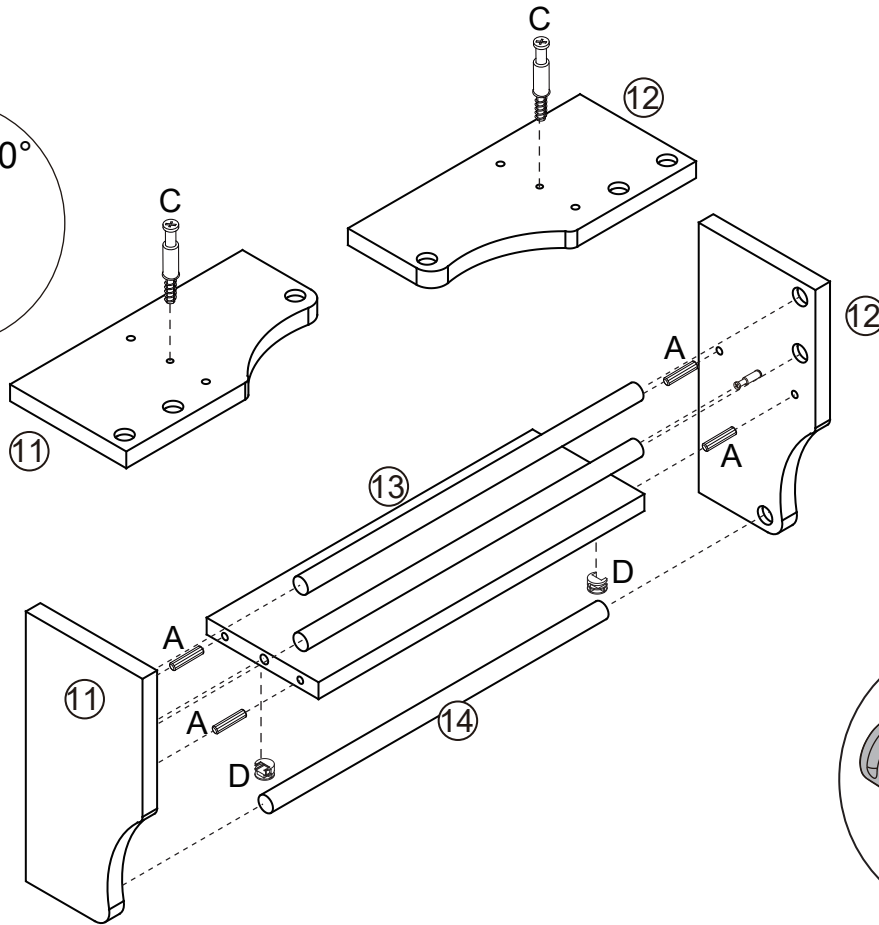
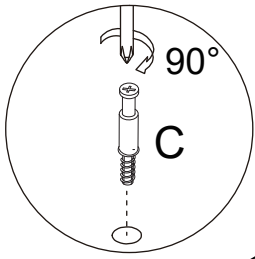

A 4PCS

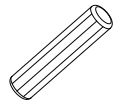

C 2PCS

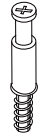

D 2PCS

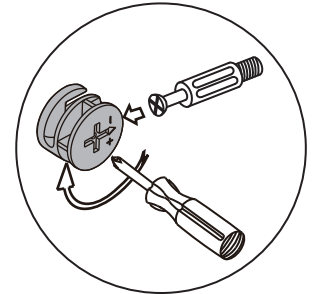

# Step 2

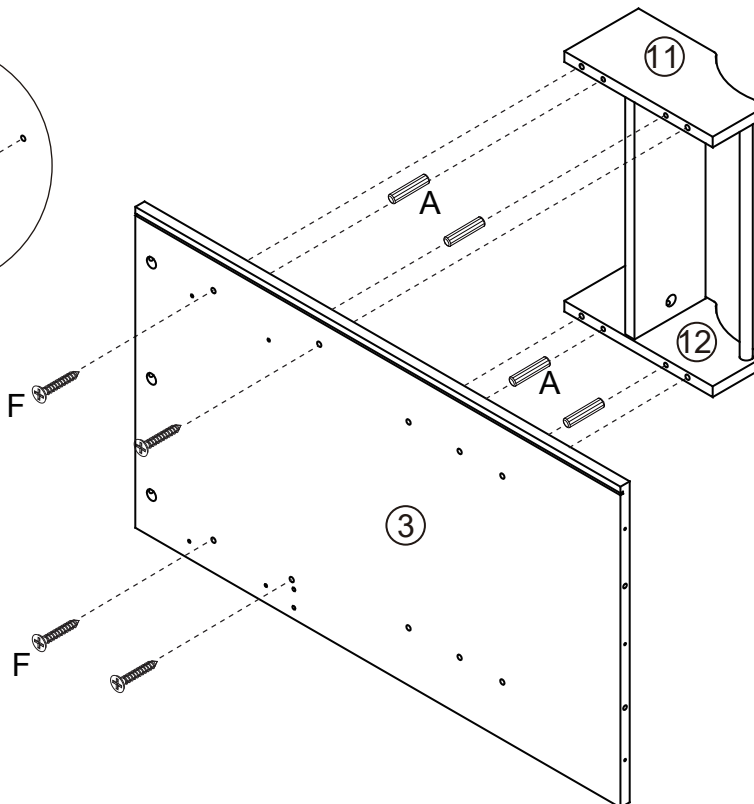
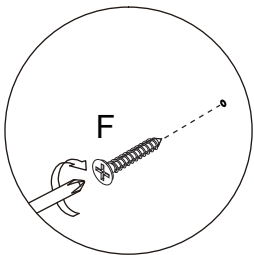

A 4PCS

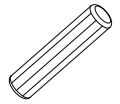

F 4PCS

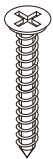

# Step 3

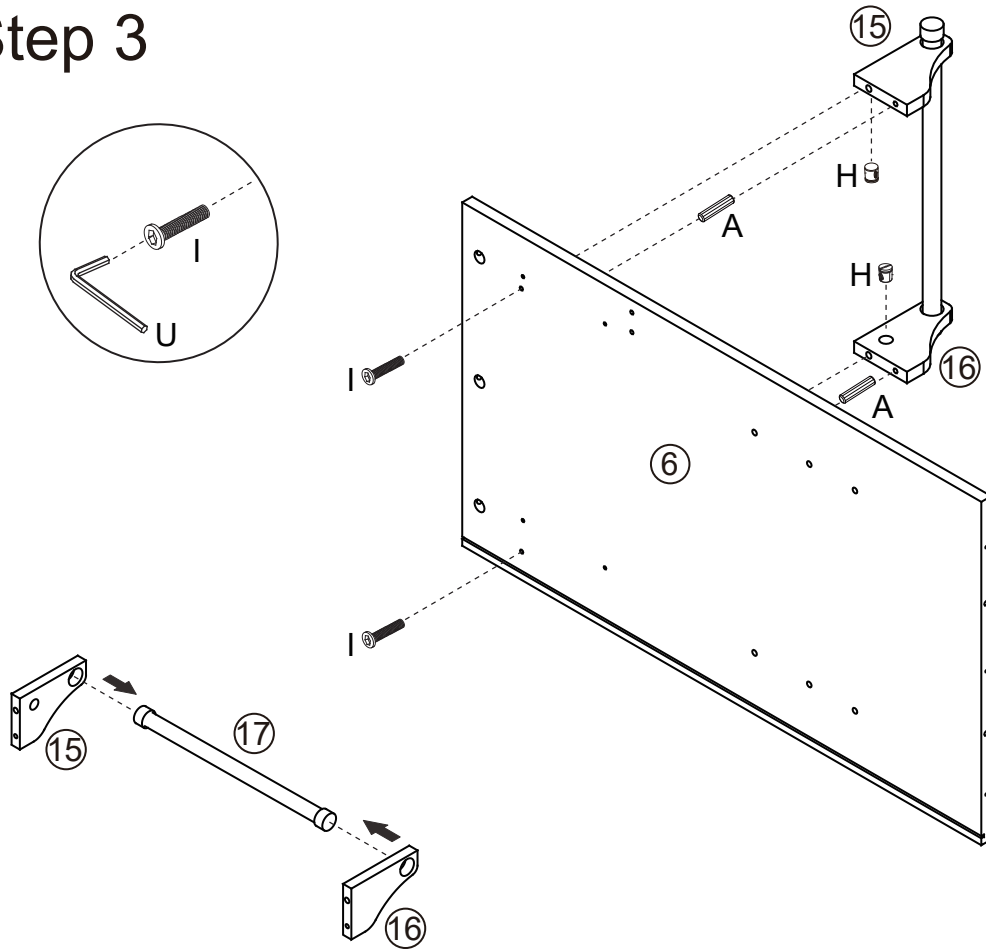

A	2PCS
H	2PCS
I	2PCS
U	1PS

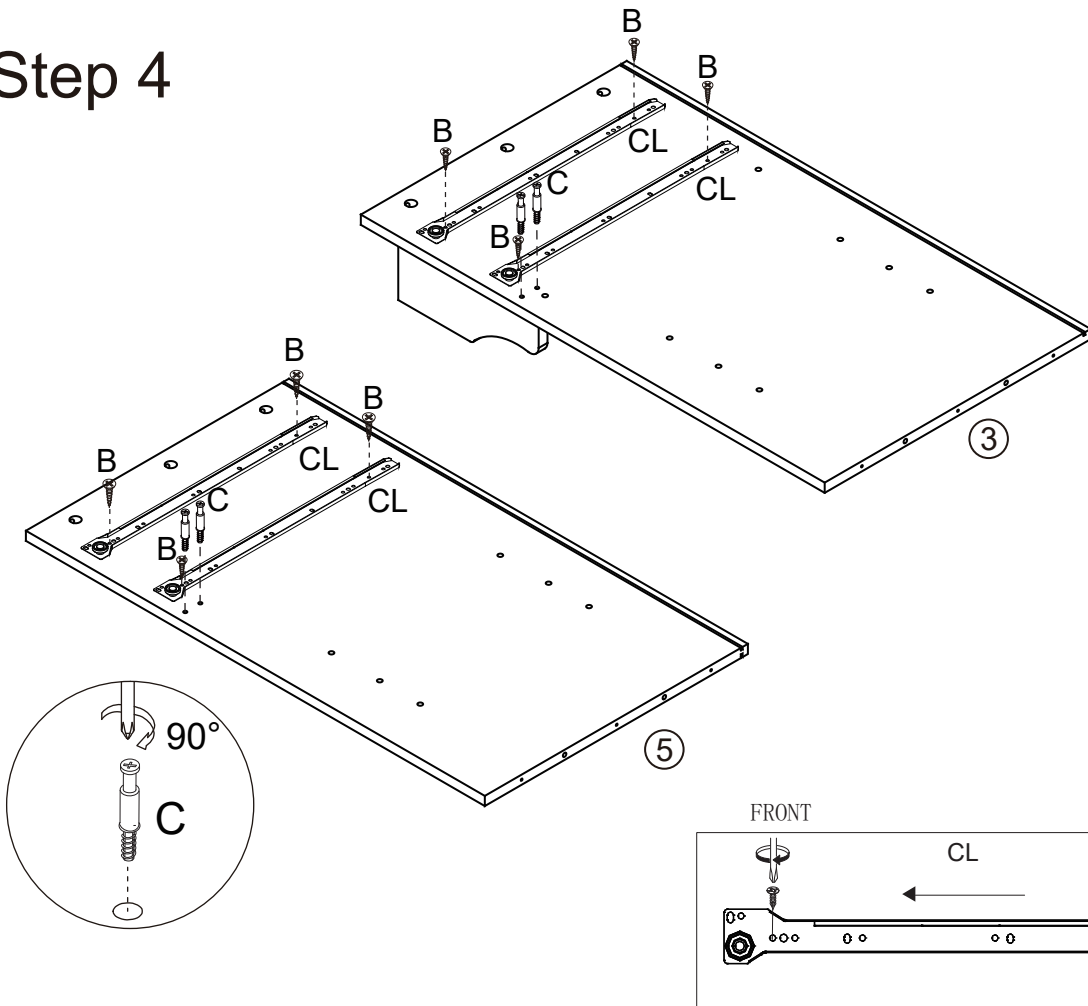

# Step 4

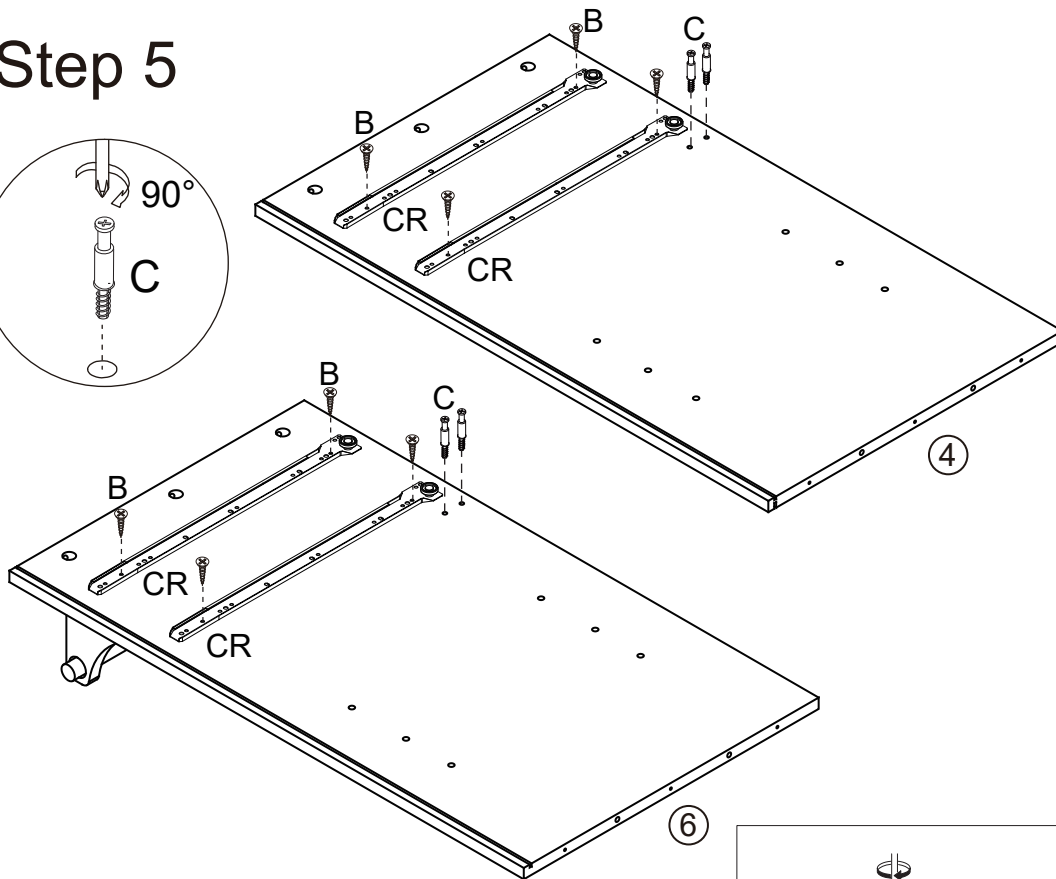
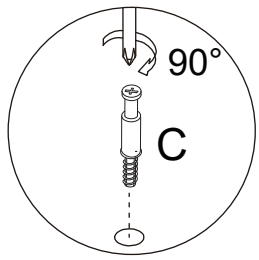

B	8PCS
C	4PCS
CL	4PCS

# Step 5



<b>B</b>	8PCS
	
<b>C</b>	4PCS
	
<b>CR</b>	4PCS
	

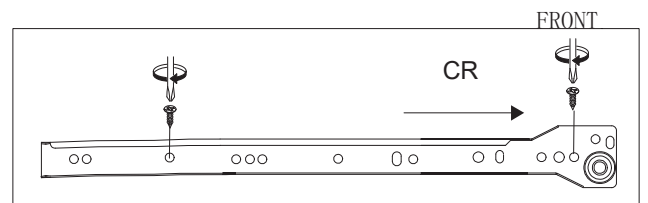

# Step 6

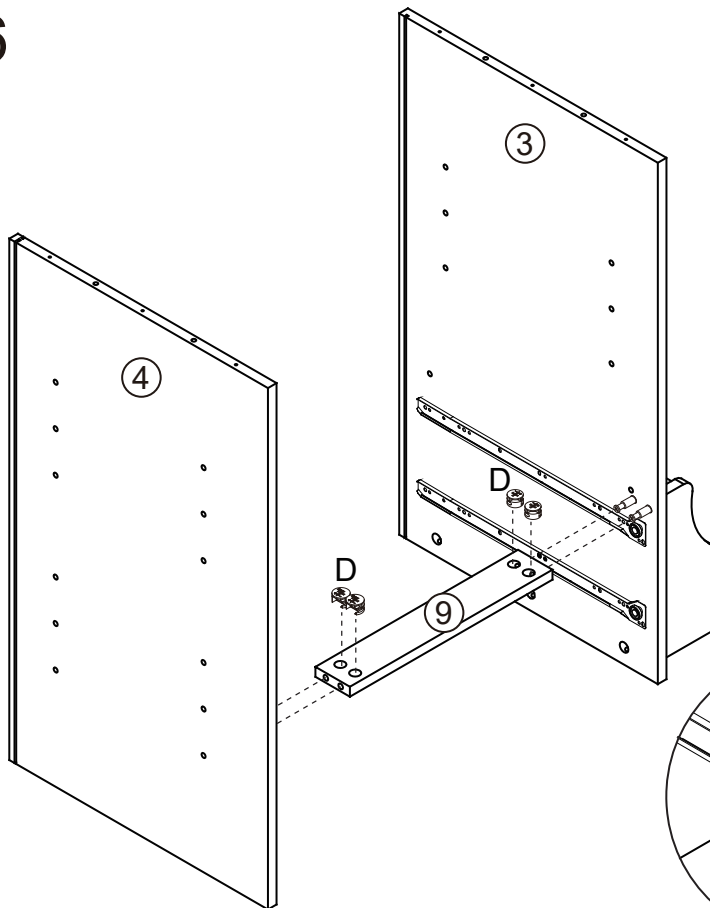

<b>D</b>	4PCS
	

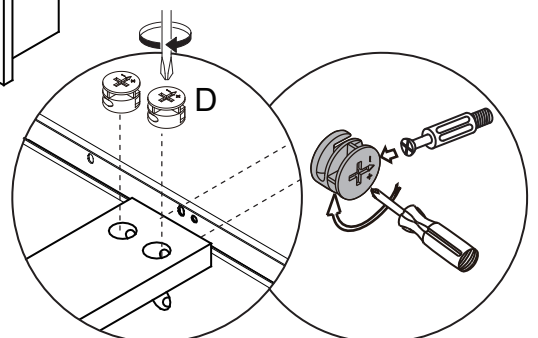

# Step 7

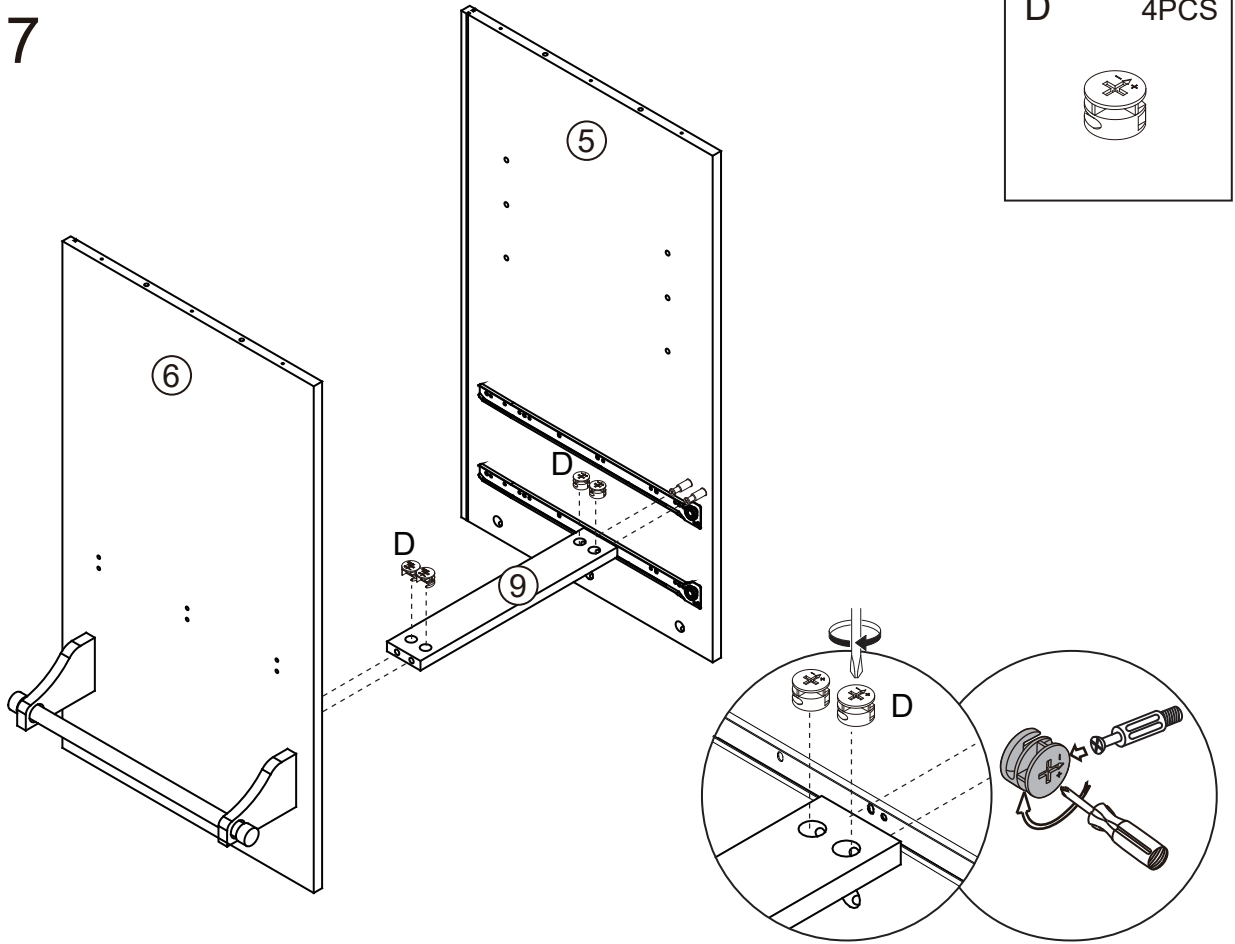

D 4PCS



# Step 8

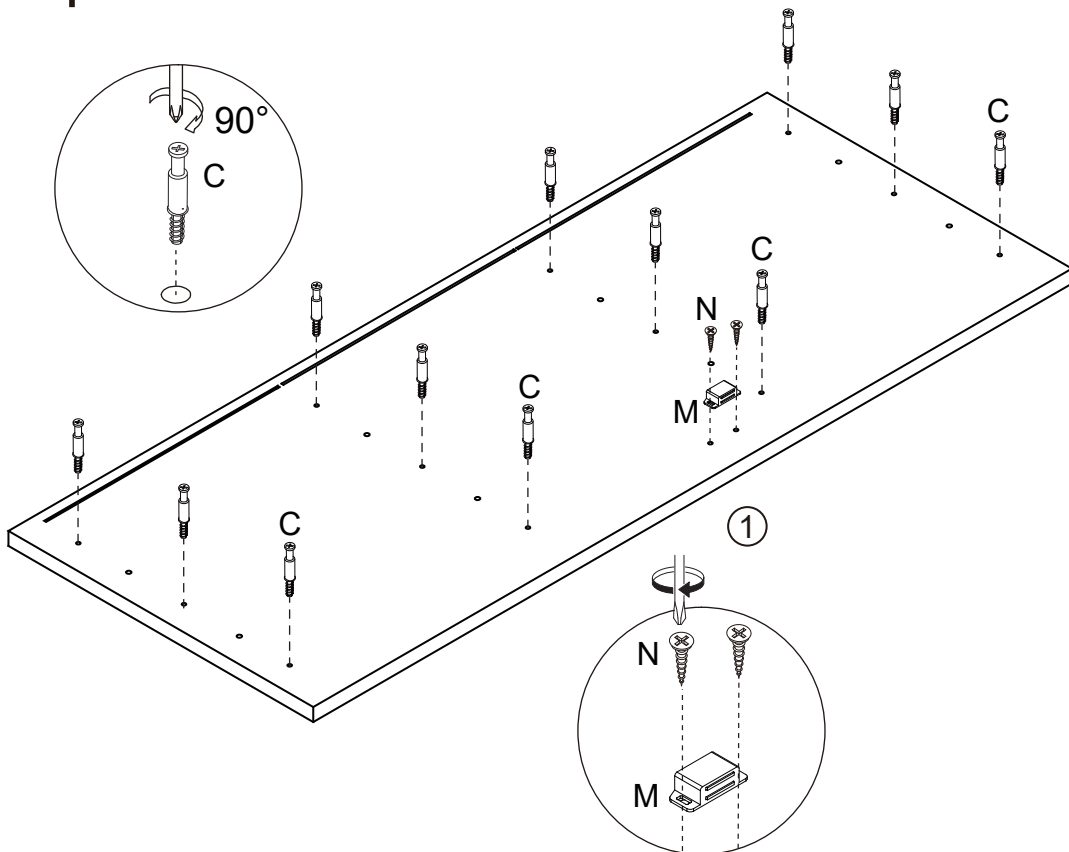

C 12PCS



M 1PS



N 2PCS



# Step 9

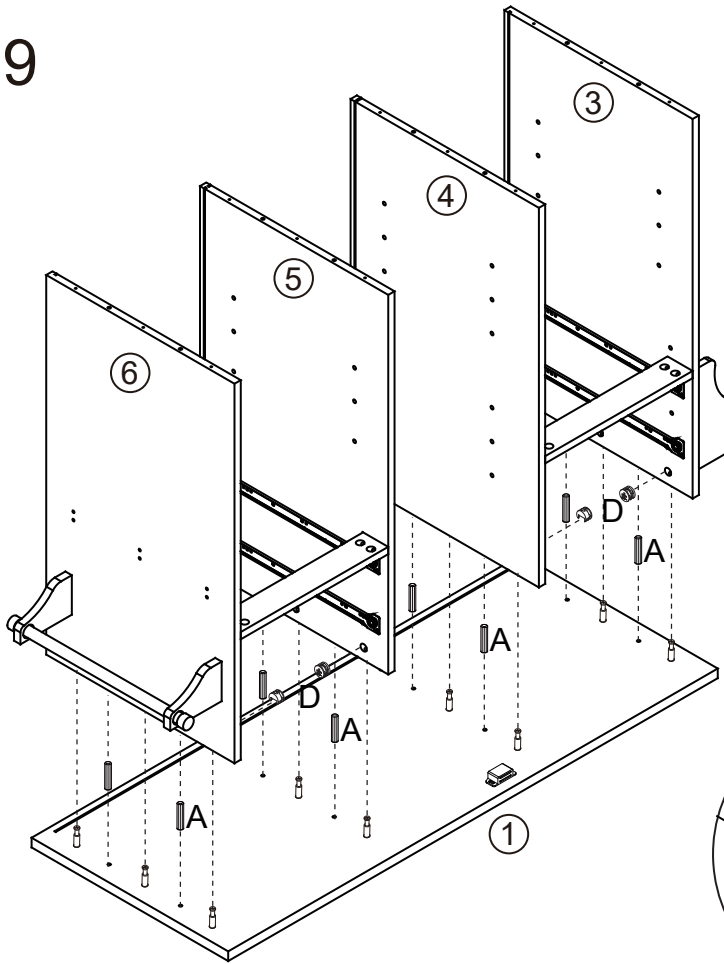

A 8PCS

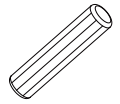

D 12PCS

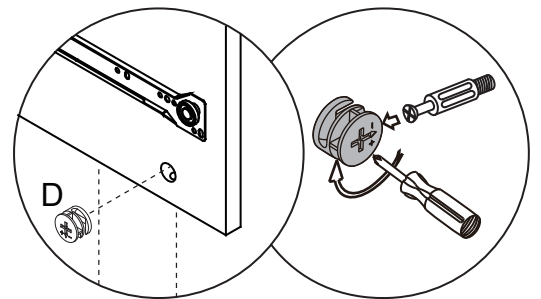

# Step 10

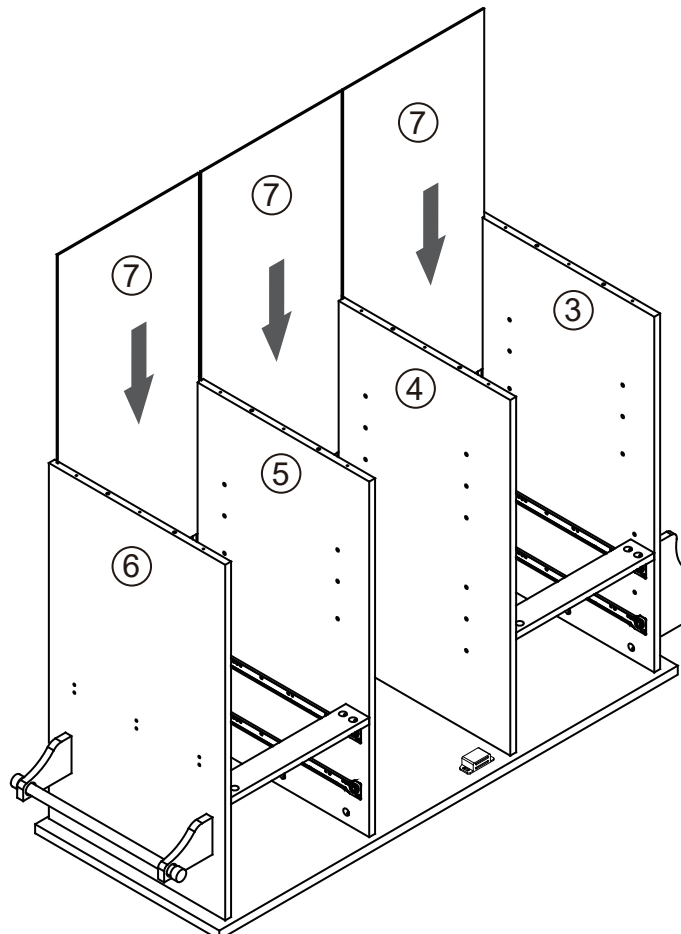

# Step 11

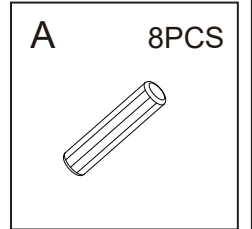
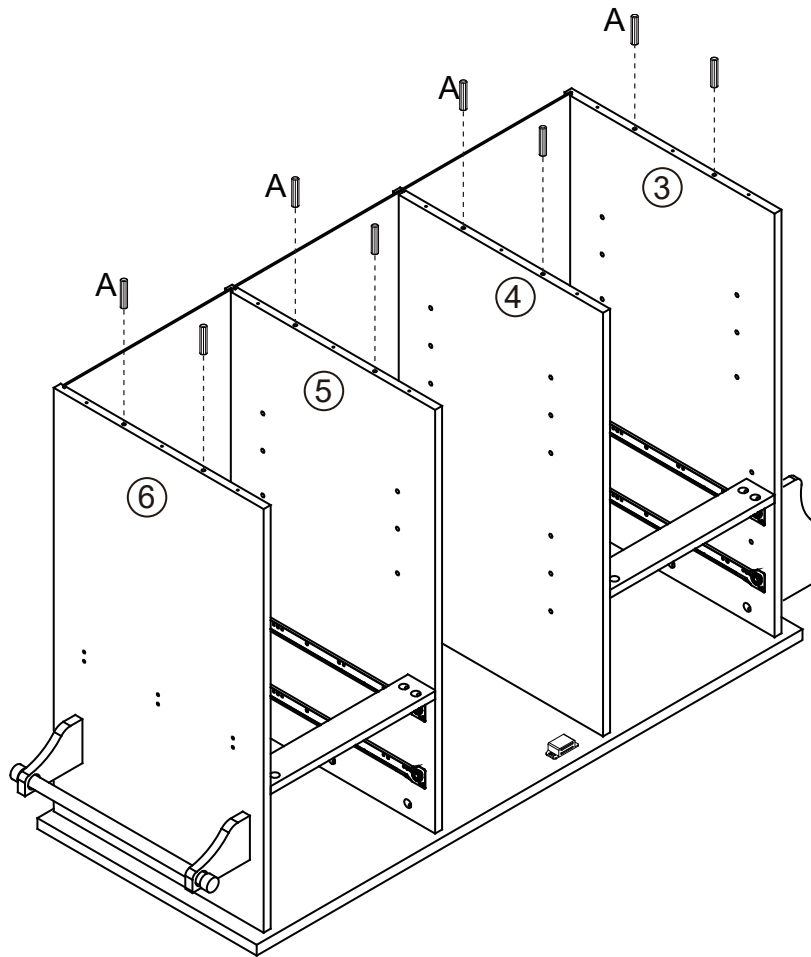

# Step 12

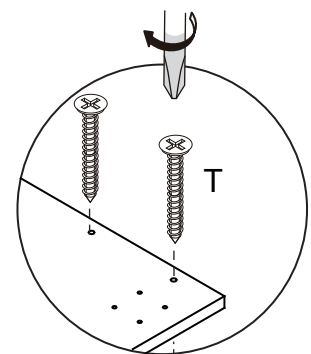
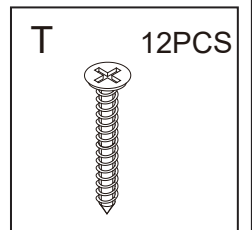
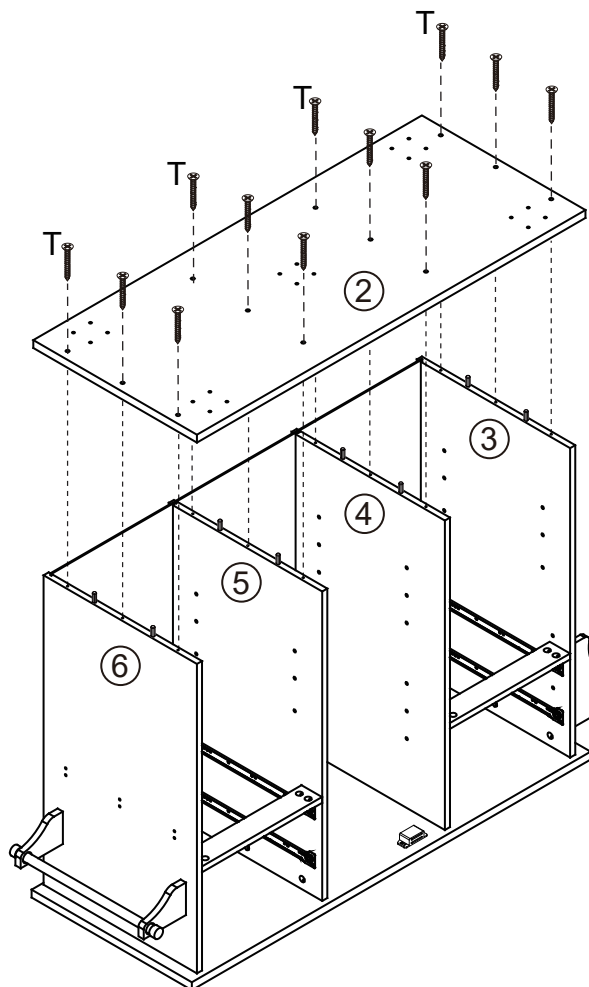

# Step 13

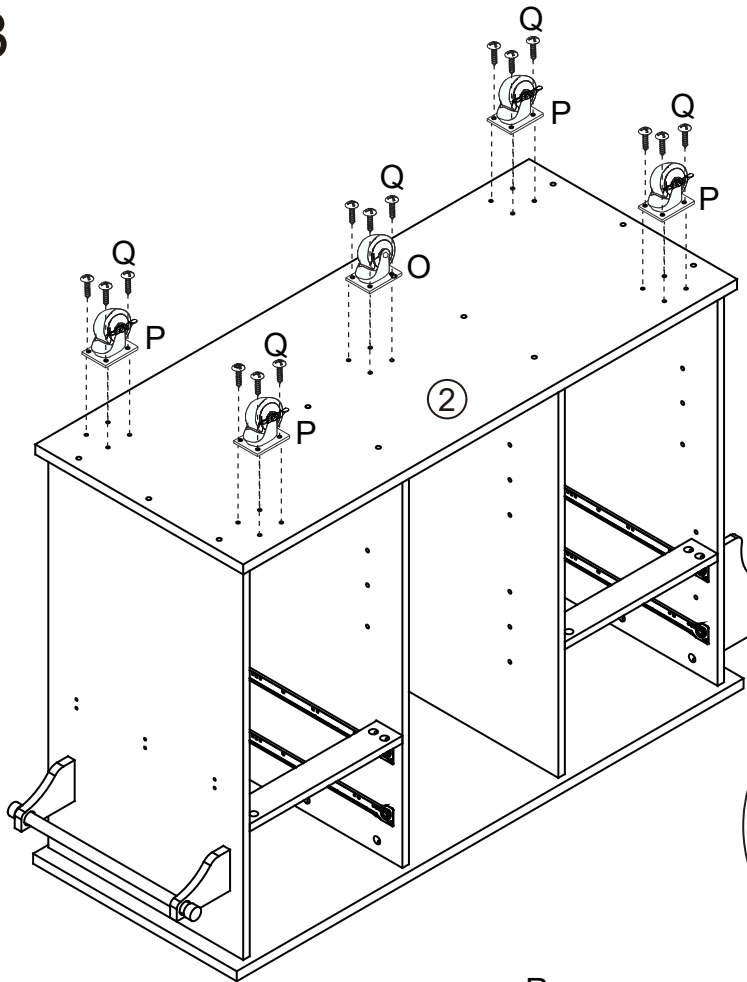

O	1PS
P	4PCS
Q	20PCS

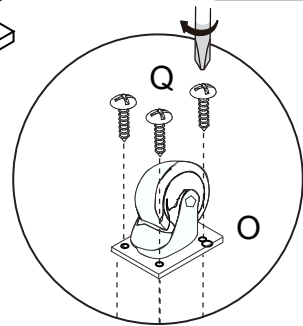

or

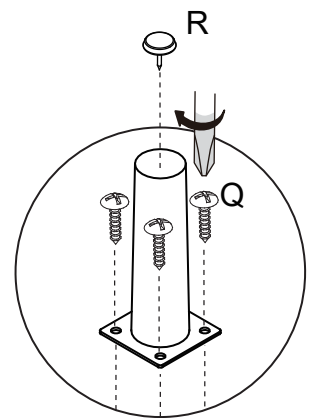
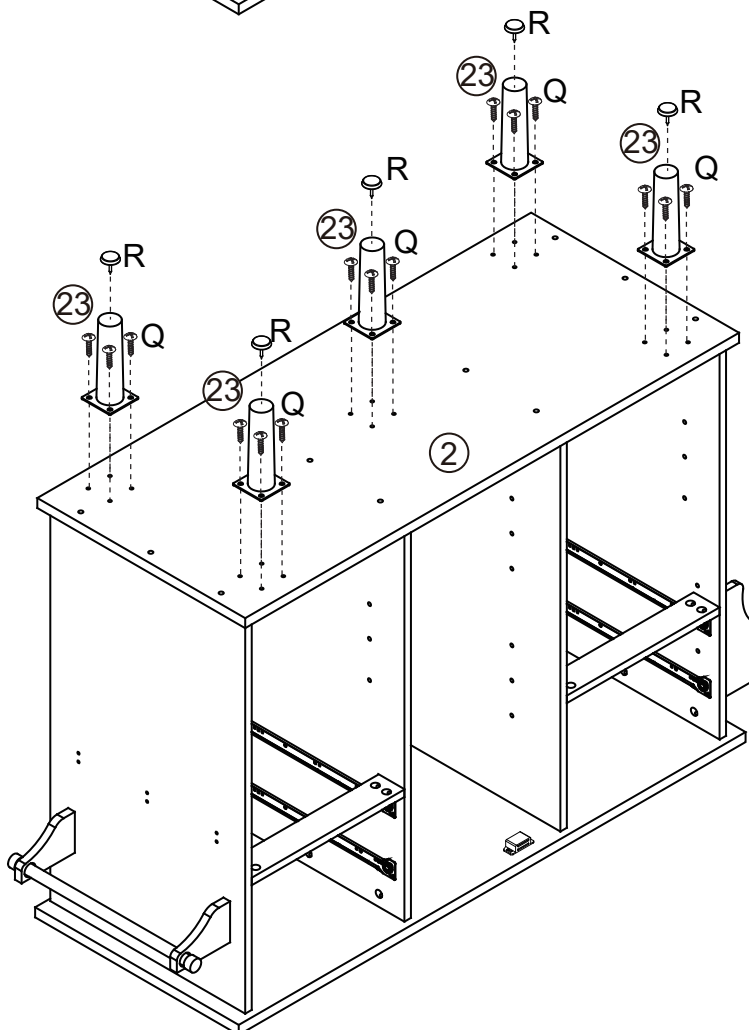

# Step 14

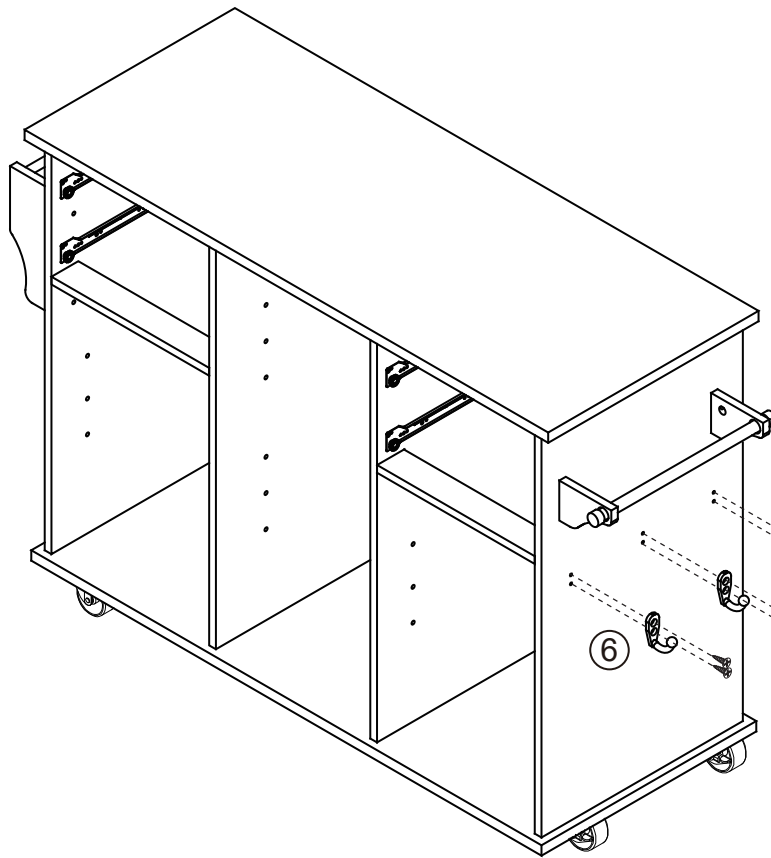

G 3PCS



N 6PCS

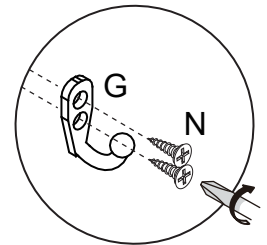

# Step 15

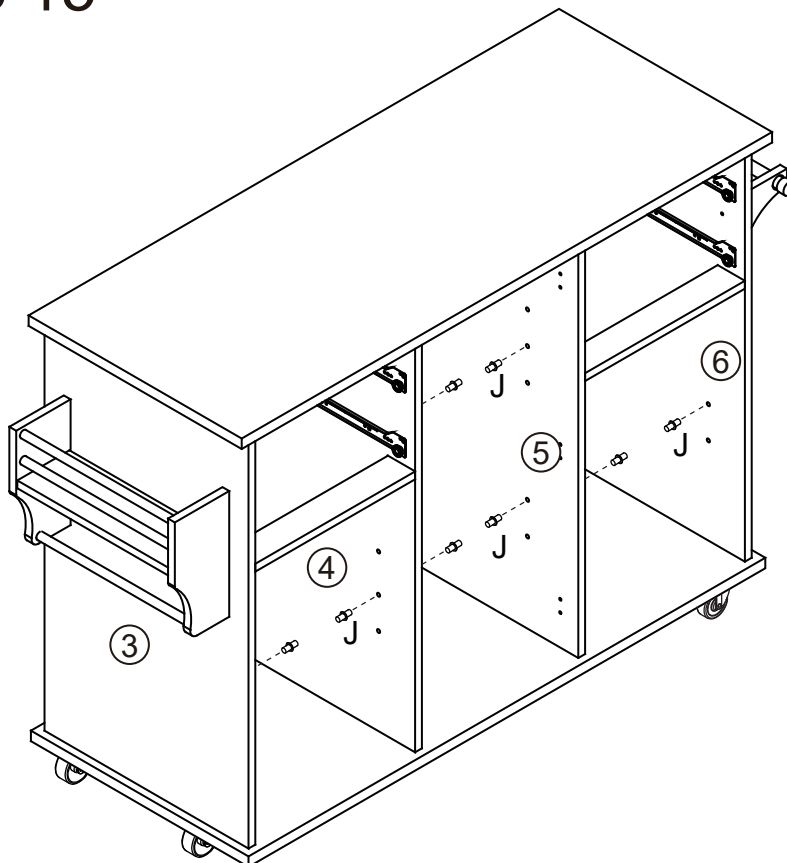

J 16PCS

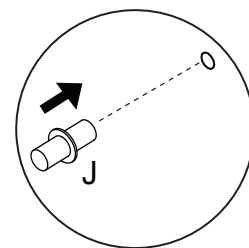
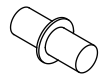

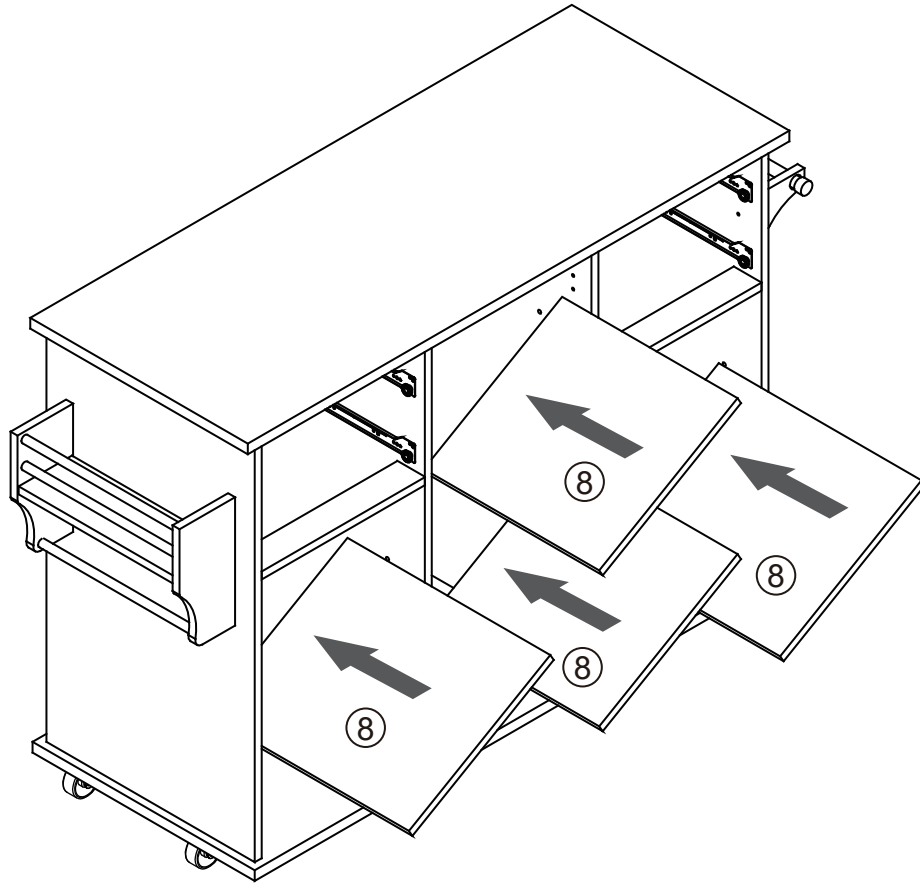

# Step 16

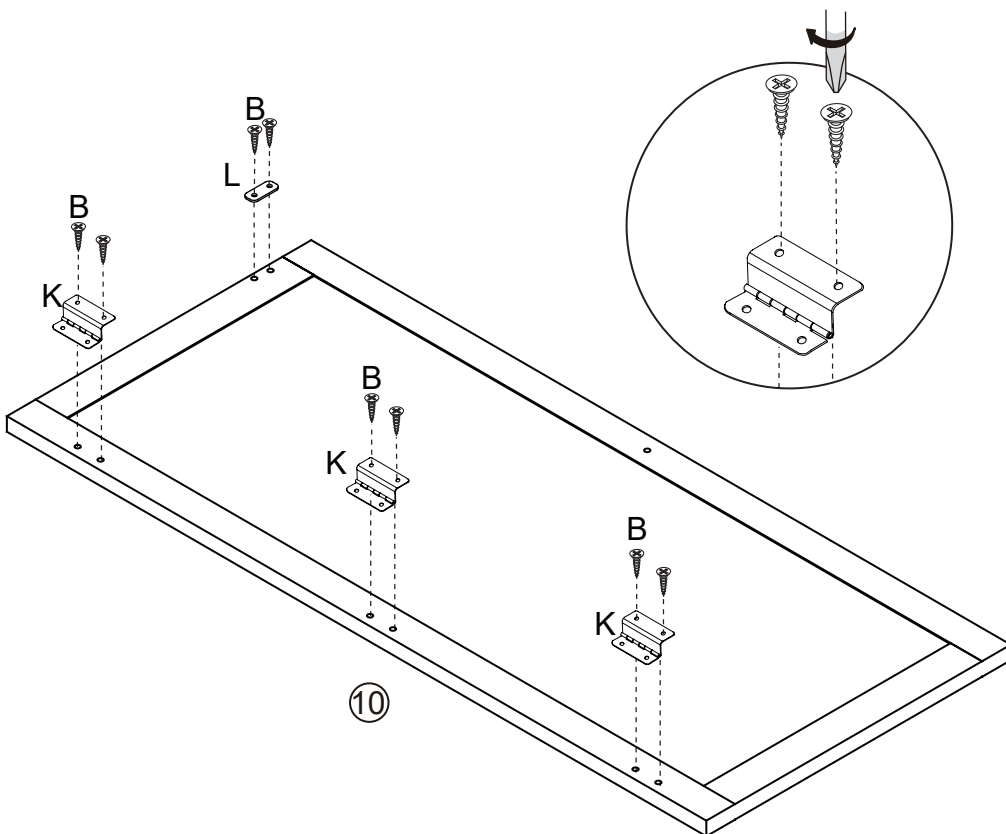

# Step 17

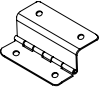

B	8PCS
	
K	3PCS
	
L	1PS
	

# Step 18

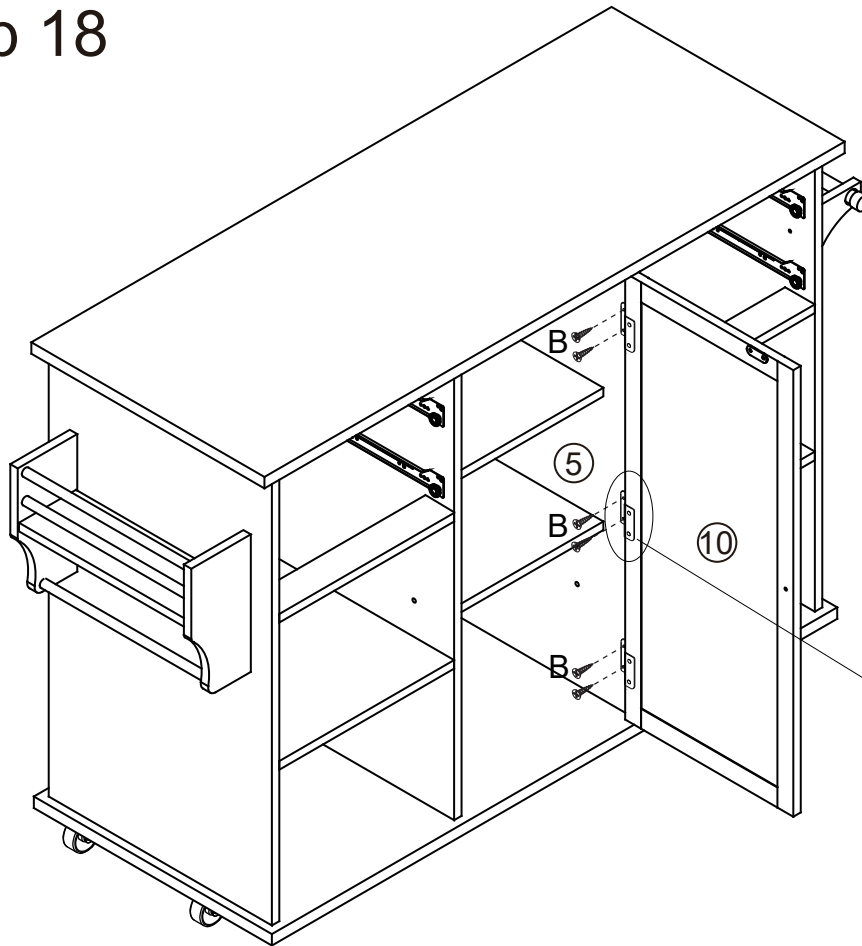

**B** 6PCS

# Step 19

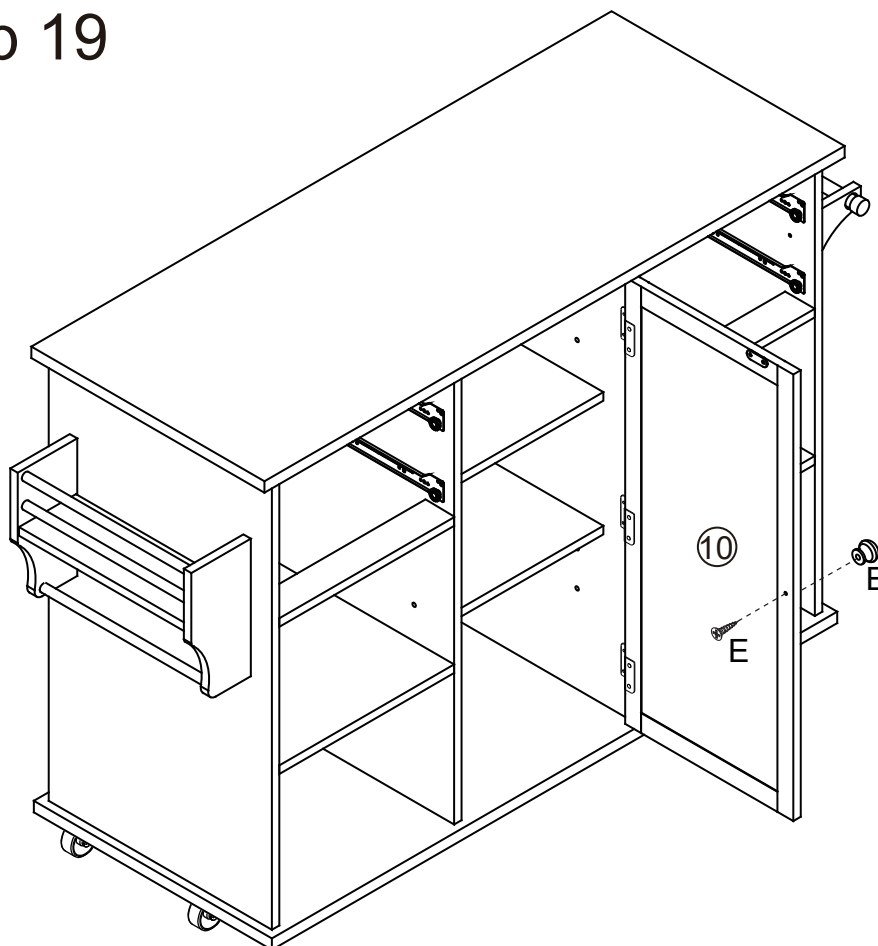

**E** 1PCS

# Step 20

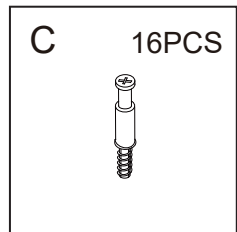
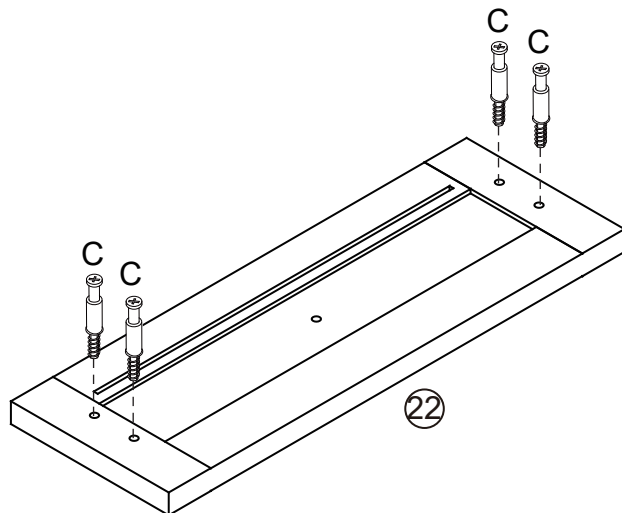

X4

# Step 21

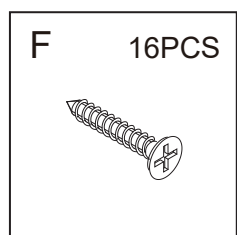
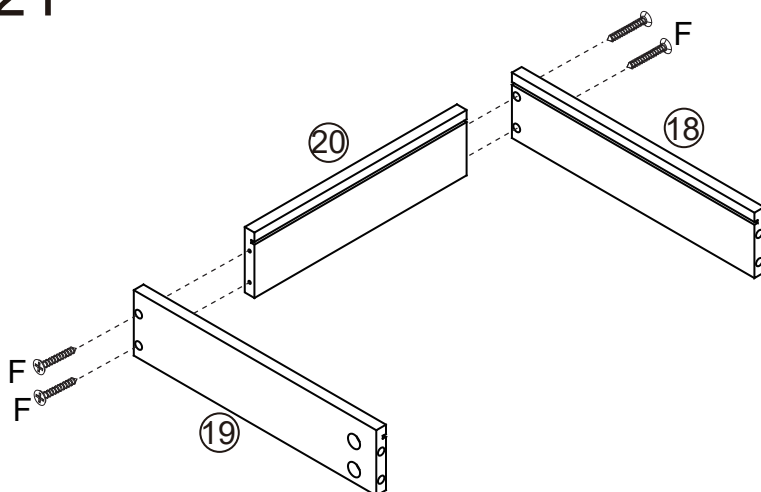

X4

# Step 22

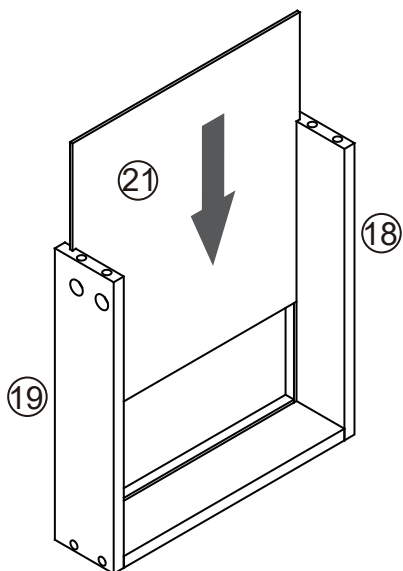

X4

# Step 23

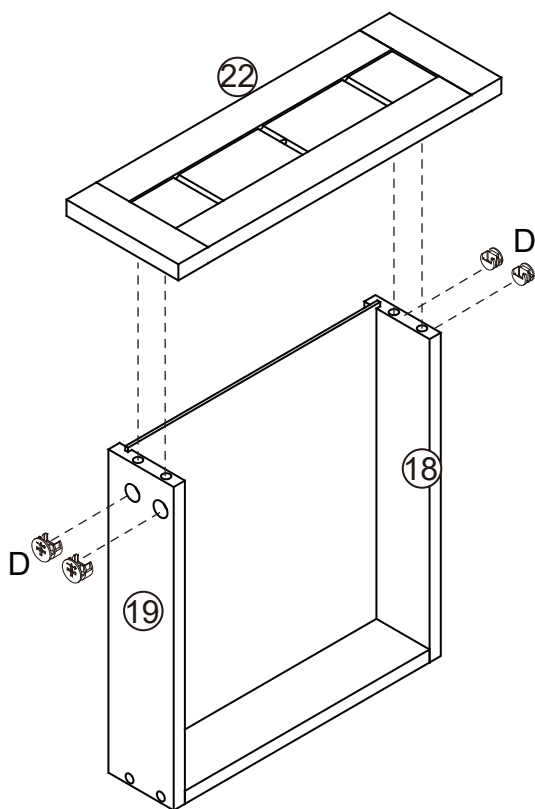

D 16PCS

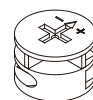

X4

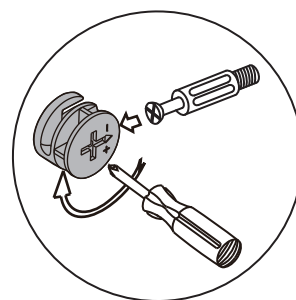

# Step 24

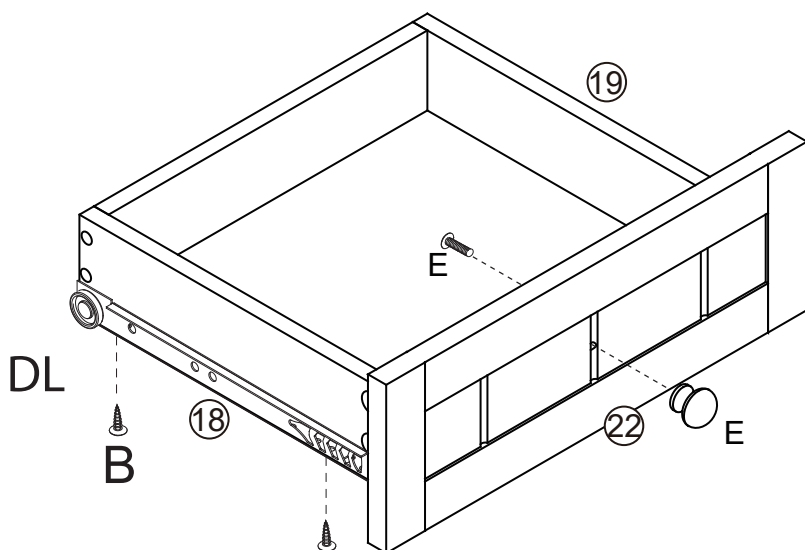

B 16PCS



E 4PCS



DL 4PCS

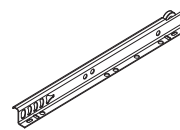

DR 4PCS

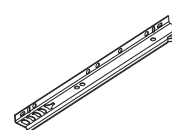

X4

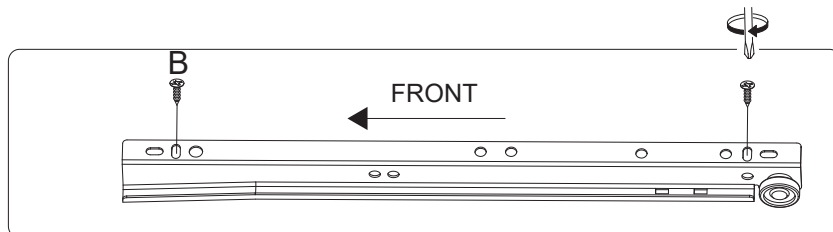
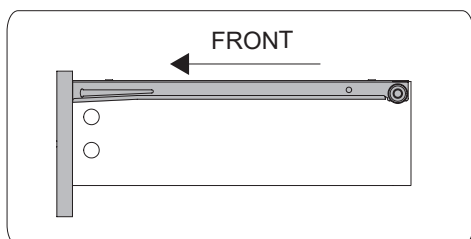

# Step 25

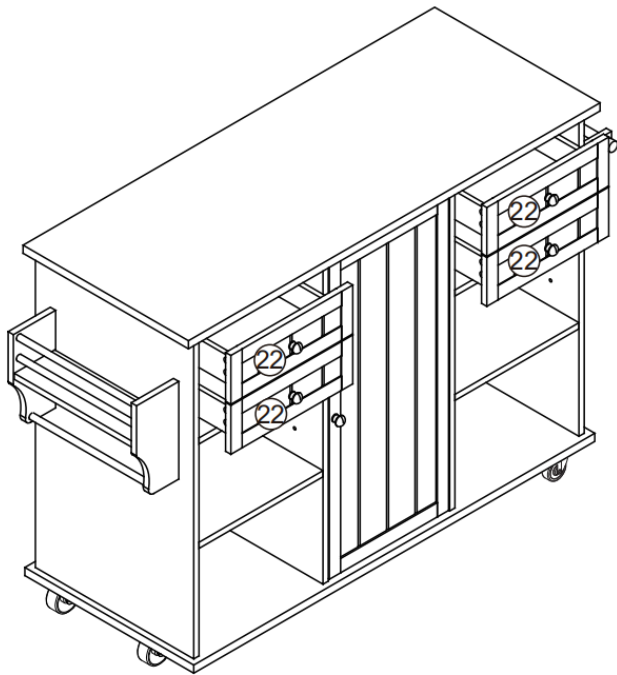

# Step 26

W 12pcs

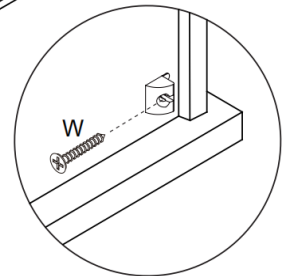
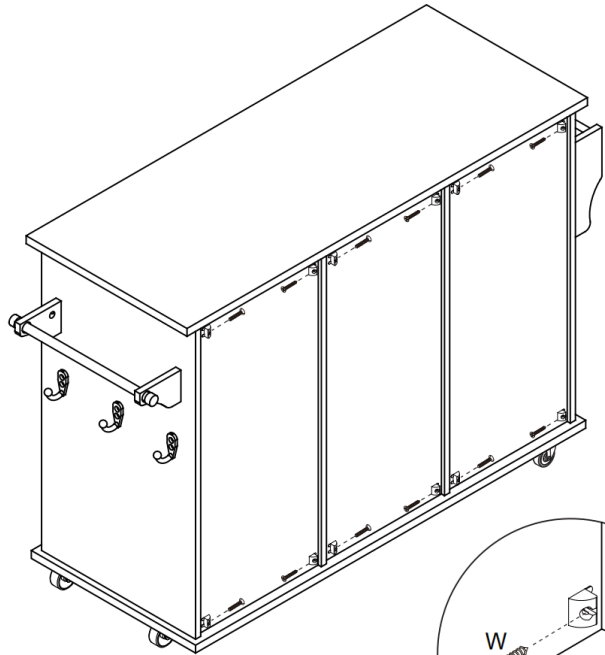

# Step 27

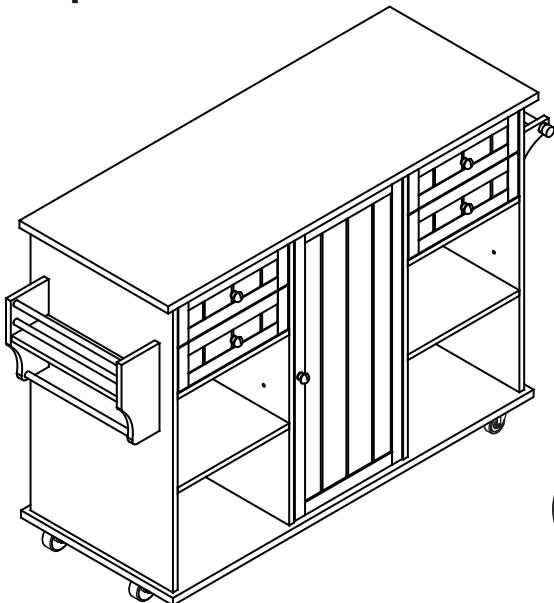

or

