

ASSEMBLY INSTRUCTIONS

Read this instruction carefully. See hardware and Furniture part list for guidance.
 Be sure all parts are complete, before you assemble. Pace all wooden prevent from being scratched.
 Follow the figure to start assembling.

CAUTIONS: 1. Do not FULLY- TIGHTEN the nut or bolt until all nut and bolt is ready assembled.
 2. Do not OVER - TIGHTEN the nut or bolt avoid causing damages to the thread.
 3. Keep all hardware parts out of reach of children.

NOTE: THE LIST AND QUANTITY SHOWN ARE FOR 1 UNIT ASSEMBLY.

PART LIST		
ITEM	DESCRIPTION	QTY
A	FRONT RAIL (L)	1 PC
B	BACK RAIL (R)	1 PC
C	ARM (L & R)	2 PCS
D	BACK REST	1 PC
E	CUSHION SEAT	1 PC

HARDWARE LIST		
ITEM	DESCRIPTION	QTY
1	WOOD DOWER M8 x 30mm	4 PCS
2	JCBC SCREW M6 x 40mm	4 PCS
3	JCBC SCREW M6 x 50mm	8 PCS
4	SPRING WASHER M6	12 PCS
5	FLAT WASHER M6 x 13mm	12 PCS
6	WOOD BUTTON 15.5mm	4 PCS
7	CSK SCREW M4 x 32mm	4 PCS
8	ALLEN KEY M4	1 PC

STEP 01

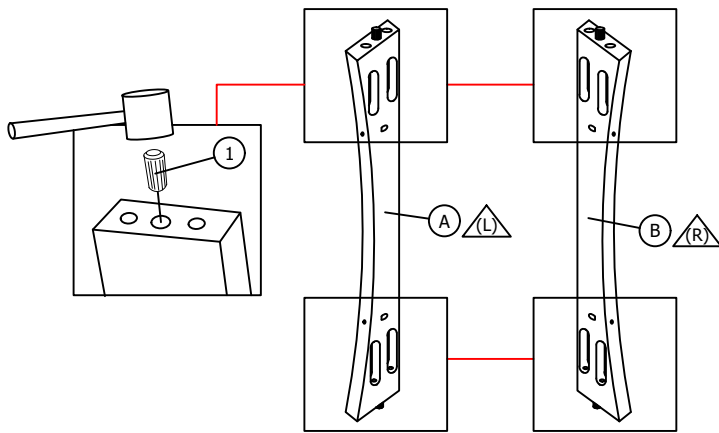

STEP 02

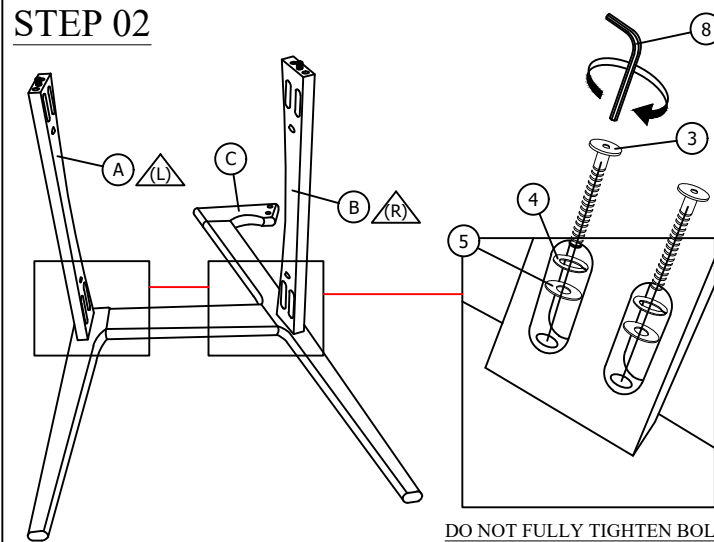

STEP 03

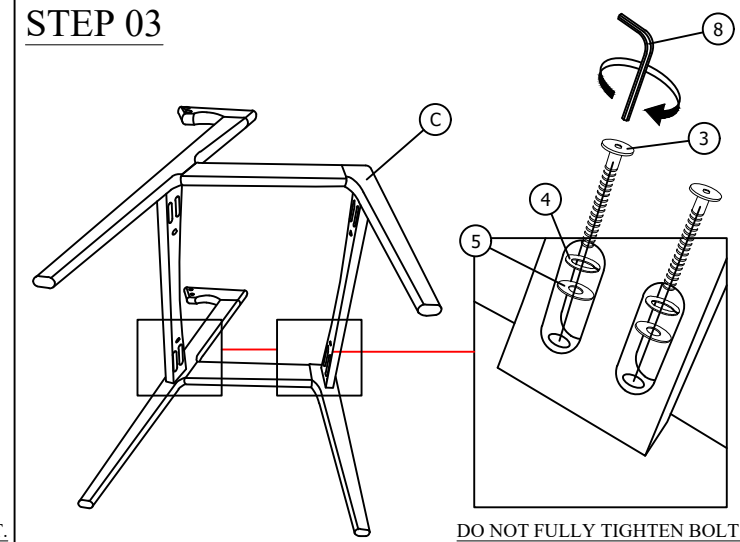

STEP 04

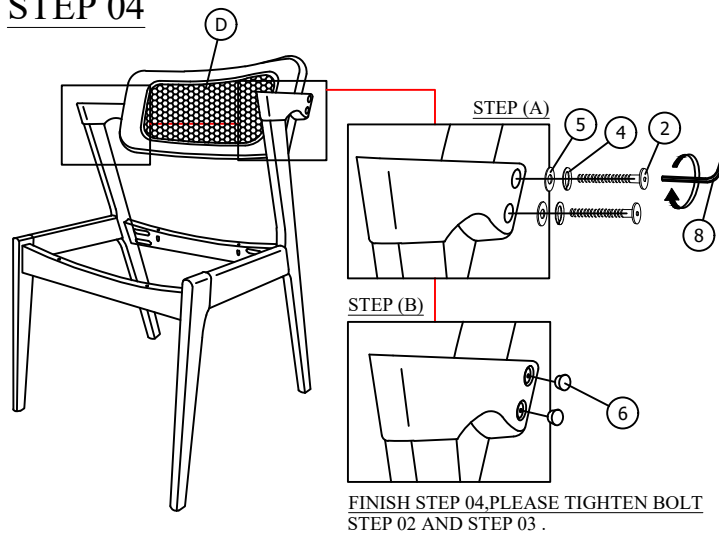

STEP 05

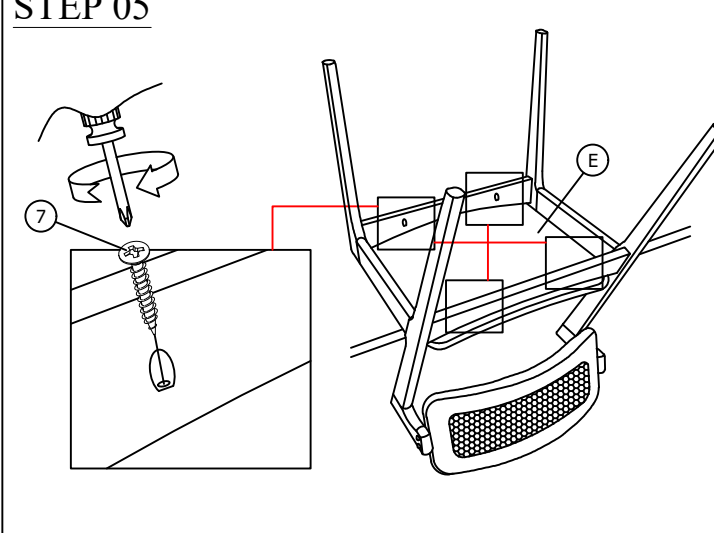

STEP 06

