

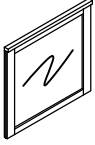

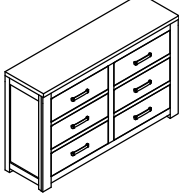

ASSEMBLY INSTRUCTION DRESSER & MIRROR

NO	PARTS LIST		
A		Mirror	1
B		Dresser	1
C		Mirror Support Rail	2
NO	HARDWARE LIST		
D		JCBC Screw M6 x 35mm	8
E		Spring Washer $\text{\O}1/4"$	8
F		Flat Washer $\text{\O}1/4" \times 20\text{mm}$	8
G		L Key M4 x 65mm	1

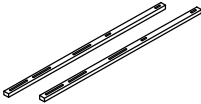

STEP 1

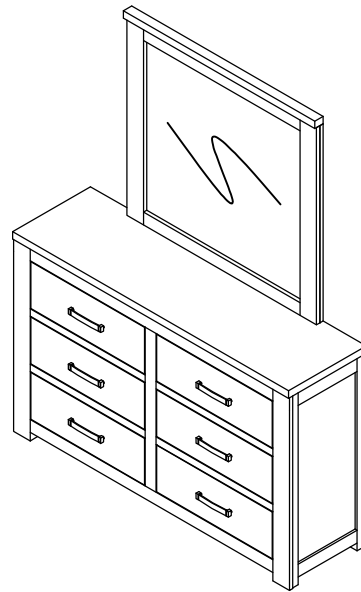
Attach Mirror Support (C) to the Mirror back (A), using JCBC M6 x35mm (D) with Spring Washer $\text{\O}1/4"$ (E), Flat Washer $\text{\O}1/4" \times 20\text{mm}$ (F). Tighten using L Key M4 (G). Make sure the marking line on mirror support is at the same level as the bottom of mirror.

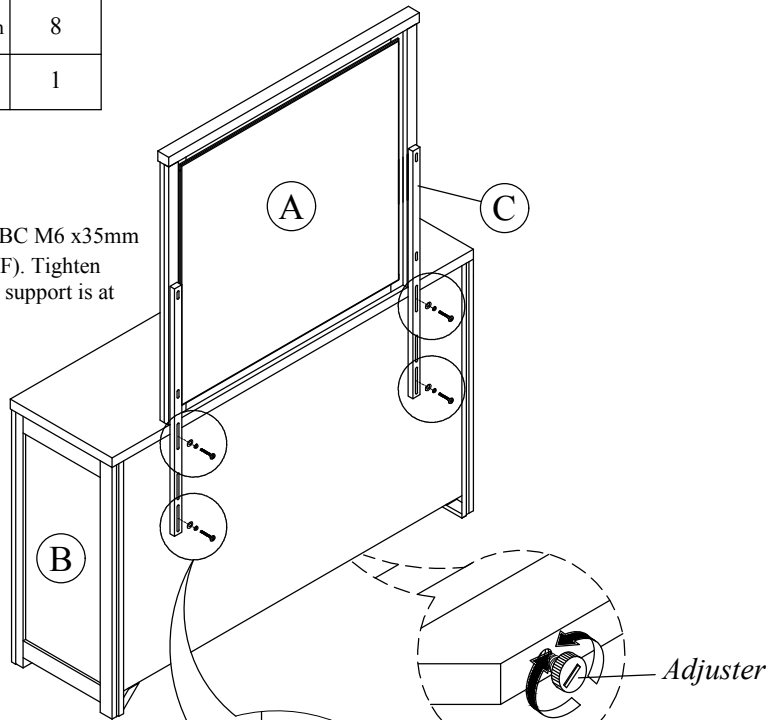
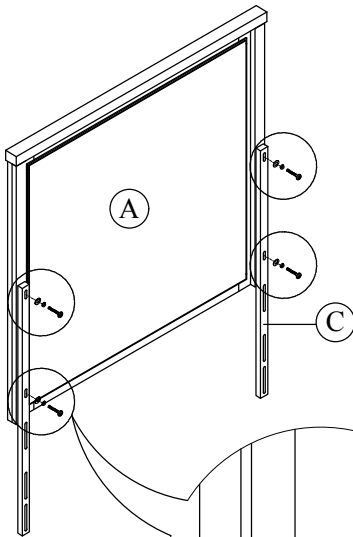

STEP 3

Adjust according to the ground level.

STEP 2

Place the mirror with support on the top of Dresser (B). Then align center as shown and using JCBC M6 x35mm (D) with Spring Washer $\text{\O}1/4"$ (E), Flat Washer $\text{\O}1/4" \times 20\text{mm}$ (F). Tighten using L Key M4 (G).