

FULL/QUEEN BED

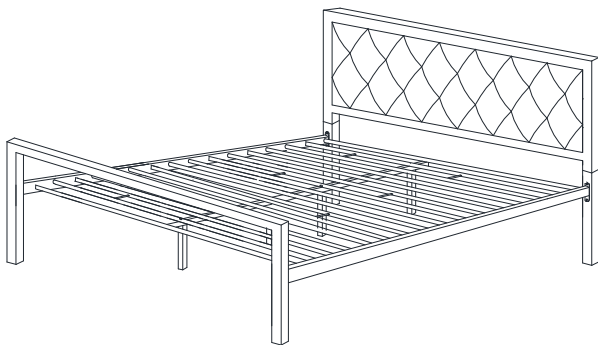







Thank you for purchasing the **FULL/QUEEN BED**!

Before you start, here is some helpful advice:

1. We suggest you spend a short time reading through this leaflet and then follow the simple step by step instructions.
2. Owing to the size and weight of the bed, we recommend that it is assembled by two adults, on a carpeted or padded area, in the room that it is intended for. Approx assembly time: 45 minutes.
3. Please do not use any tools other than those provided or recommended in these instructions.
4. Please do not throw away any of the packaging or the instruction until you have checked all the components and hardware and the furniture is fully assembled. Please ensure that the packaging is disposed of in a safe environmentally friendly way.
5. Assemble all components loosely until advised to tighten. Depending on use, it may be necessary to tighten the components from time to time, so please save the tools that has been provided.
6. Please keep all fitting out of reach of children.



Hardware:

A		Short Bolt M6x20mm	x28
B		Medium Bolt M6x35mm	x4
C		Long Bolt M6x50mm	x4
D		Nut M6	x8
E		Flat Washer	x4
F		Rubber Insert	x16
G		Allen Wrench	x1
H		Open Wrench	x1

Component:

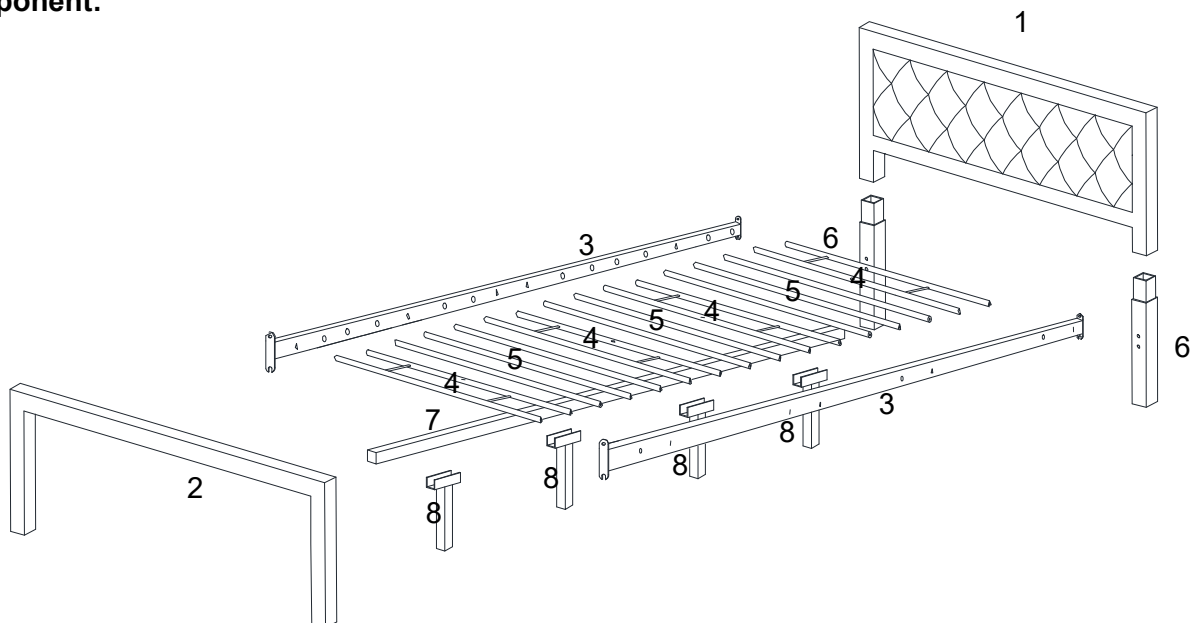

1	Headboard	x1
3	Side Rail	x2
5	Single Slat	x8
7	Center Rail	x1

2	Footboard	x1
4	Double Slat	x4
6	Low Post	x2
8	Support Leg	x4

FULL/QUEEN BED

STEP 1:

Insert **Low Post (6)** into **Headboard (1)** as shown.

Attach by using **Flat Washer (E)** and **Short Bolt (A)** from the holes on the back of **Low Post (6)** and **Headboard (1)**.

Use **Allen Wrench (G)** to tighten **Short Bolts (A)** clockwise until secure.

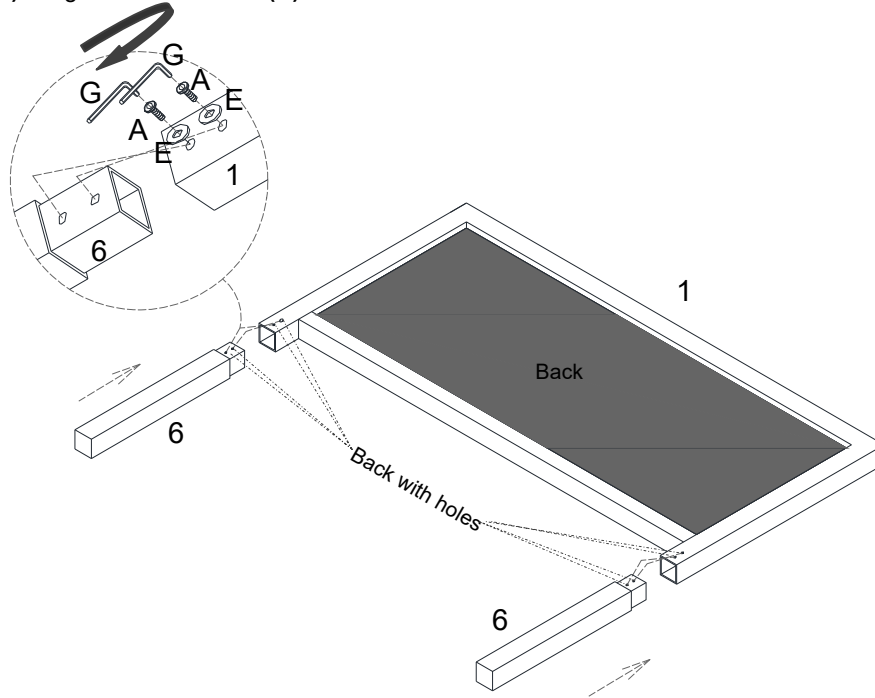

Ax4	Ex4	Gx1

Hardware & Tool required

STEP 2:

Take out all **Double Slats (4)**, **Single Slats (5)** and **Side Rails (3)** and place them as shown.

Insert one end of **Single Slats (5)** into **Rubber Insert (F)**, then insert them into the corresponding holes on one piece of **Side Rail (3)** as shown.

Attach **Double Slats (4)** to the same **Side Rail (3)** by using **Short Bolts (A)**. Do not fully tighten **Short Bolts (A)** with **Allen Wrench (G)** yet.

Repeat above for the other **Side Rail (3)**.

Use **Allen Wrench (G)** to tighten all **Short Bolts (A)** clockwise until secure.

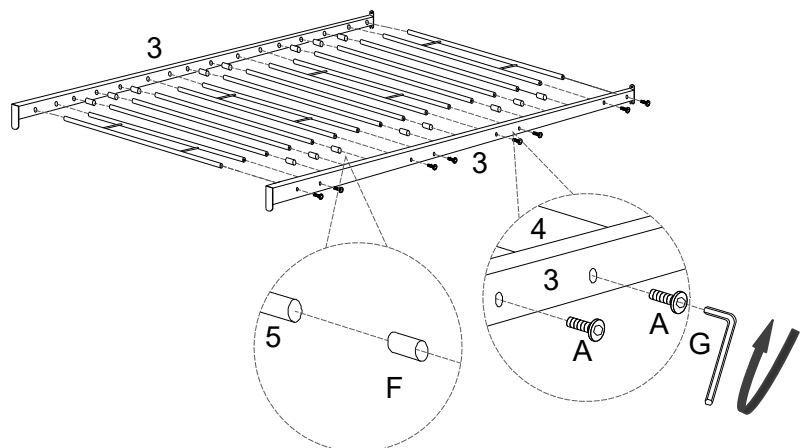
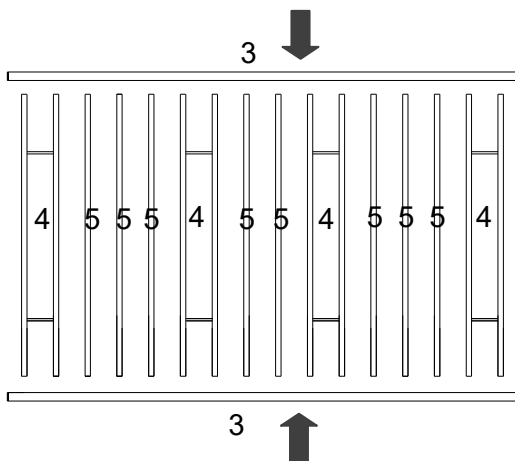

Ax16	Fx16	Gx1

Hardware & Tool required

FULL/QUEEN BED

STEP 3:

Place **Center Rail (7)** and 4 pieces of **Support Leg (8)** under assembled **Double Slat (4)** and **Single Slat (5)** as shown. Insert 4 pieces of **Long Bolt (C)** into the 4 holes right on **Center Rail (7)** to connect it with **Support Legs (8)** as shown. Insert 4 pieces of **Medium Bolt (B)** into 4 other holes left on **Center Rail(7)** to connect it with **Support Legs (8)** as shown. Secure the above 8 pieces of **Bolts (B&C)** with **Nuts (D)** from the bottom of **Support Legs (8)** at same time. Use **Allen Wrench (G)** and **Open Wrench (H)** to tighten all **Bolts (B&C)** and **Nuts (D)** until secure.

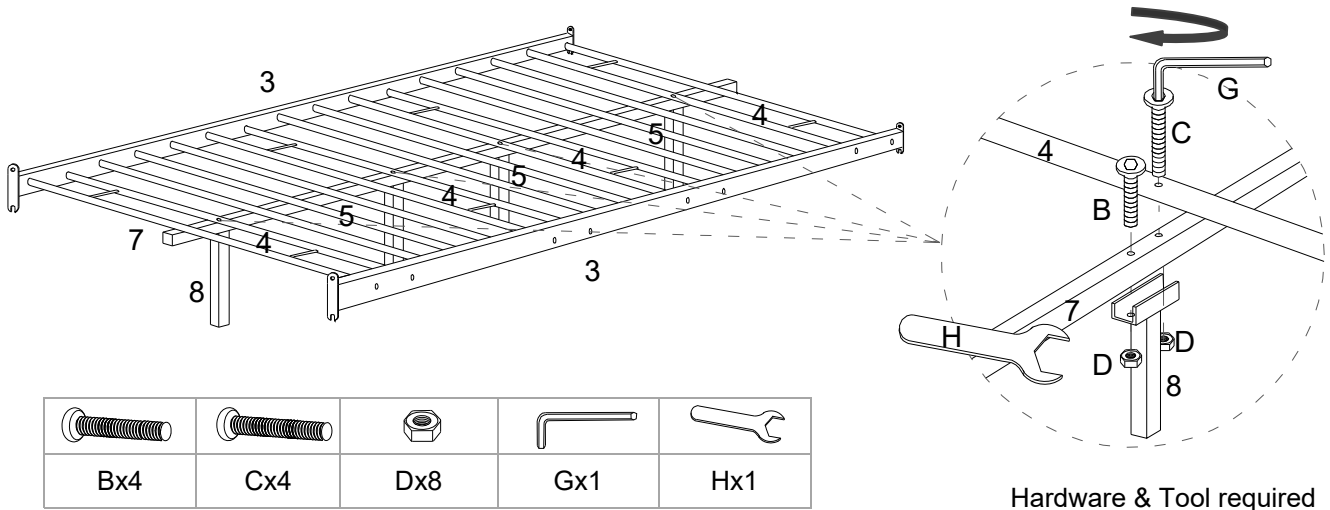

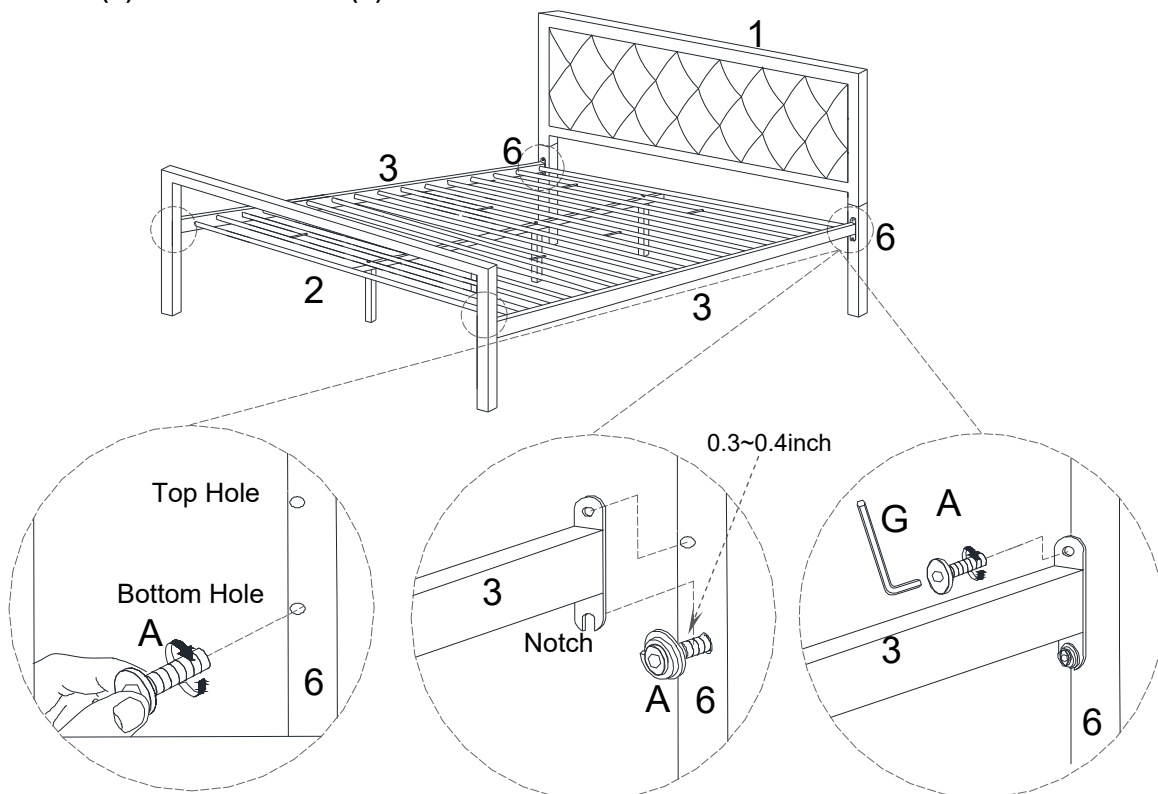

STEP 4:

Insert **Bolts (A)** into the bottom holes on the assembled **Headboard (1&6)** & **Footboard (2)** by hand. Leaving 0.3~0.4inch space of the thread of **Bolts (A)** as shown for inserting the notch of assembled **Side Rails (3&4&5)**. Insert the notch of assembled **Side Rails(3&4&5)** into the space left on the **Bolts (A)**. Screw **Bolts (A)** into the top holes on the assembled **Headboard (1&6)** & **Footboard (2)** as shown. Tighten **Bolts (A)** with **Allen Wrench (D)** after all assembled.



Assembly is completed. Your bed is ready to be enjoyed now!

	
AX8	Gx1

Hardware & Tool required