

ASSEMBLY INSTRUCTION

SKU CODE: WF038854

Double Bed

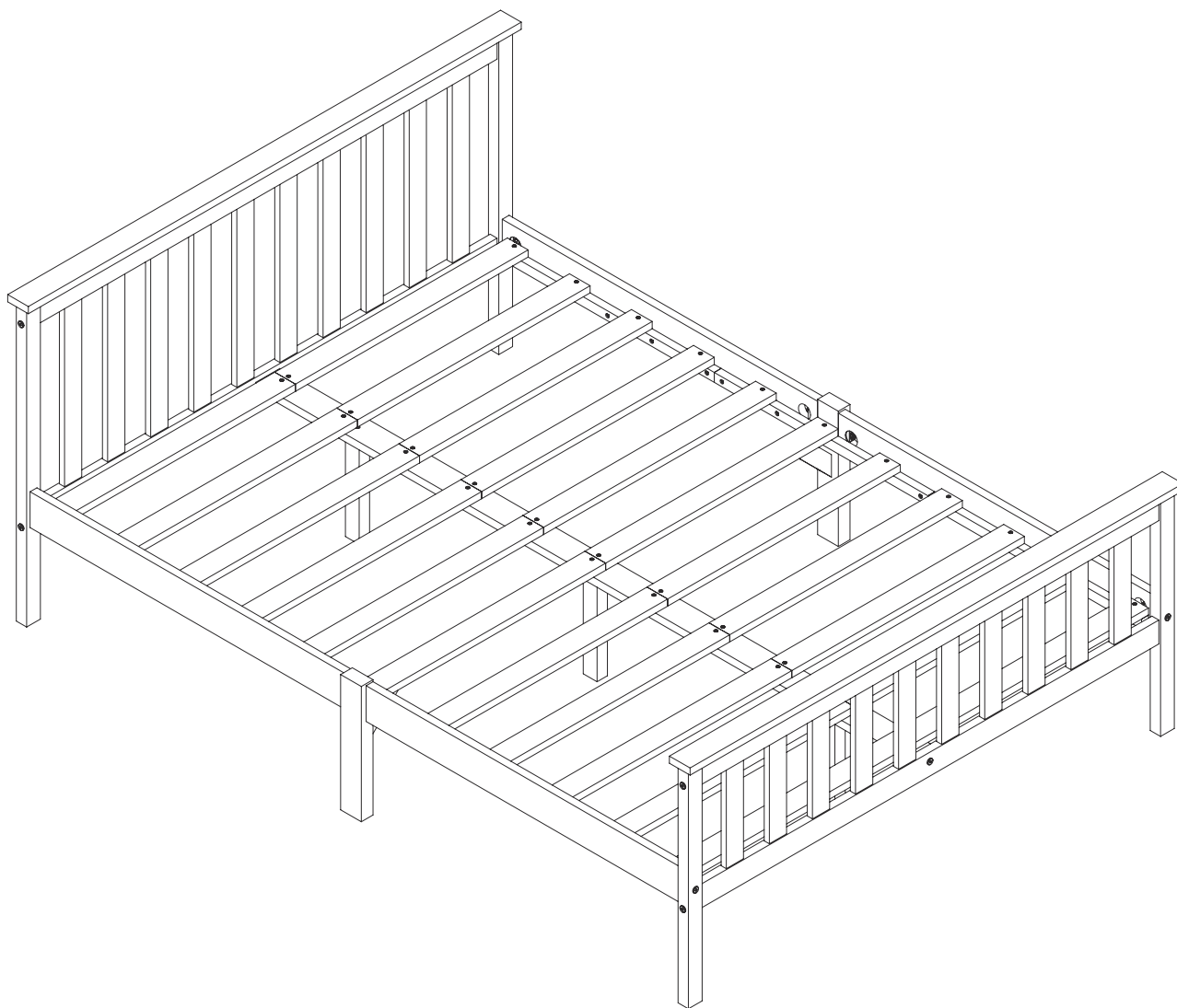

(D) Gebrauchsanweisung

(NL) Gebruiksrichtlijnen

(IT) Istruzioni per l'uso

(CZ) Pokyny k použití

(HU) Használati útmutató

(PT) Instruções de utilização

(SK) Pokyny k použitiu

(GB) Instructions for use

(FR) Instructions d'utilisation

(PL) Instrukcja obsługi

(ES) Instrucciones de empleo

(RO) Instrucțiuni de folosire

(RU) Инструкция по монтажу

(TR) Kullanım talimatları

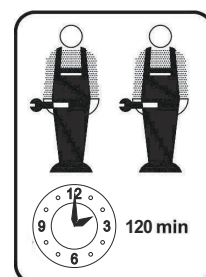

Reminder/ Hinweis



D CH AT LI LU	Kleinteile und Verpackungsfolien von Kindern fernhalten!
GB US	Keep small parts and plastic film out of the reach of children!
FR BE NC	Tenir les petites pièces et les films plastiques hors de la portée des enfants!
NL	Houd de kleine onderdelen en de plastic folie uit de buurt van kinderen!
IT	Tenere i componenti di piccole dimensioni e le pellicole di plastica fuori dalla portata dei bambini!
SI	Majhnih delov in embalažne folije pri montaži pohištva hranite izven dosega otrok!
XS HR BA	Male dijelove i foliju za pakovanje prilikom montaže namještaja držite dalje od djece
HU	Bútorszerelés közben a kis alkatrészek és a csomagoló fóliák gyermekektől távol tartandók!
BG	Дребни детайли и опаковъчни фолиа да се държат далеч от деца при монтажа на мебелите!
CZ SK	Při montáži nábytku uchovávejte drobné díly a obalové fólie z dosahu dětí!
PT	Mantenha peças pequenas e películas de embalagem afastadas de crianças!
RO	Țineți departe de copii piesele mici și folia de ambalat la montarea mobilei!
ES	¡Durante el montaje, mantenga alejados de los niños las piezas pequeñas y el material plástico de embalaje!



D CH AT LI LU	Möbelmontage muss auf ebenem Untergrund erfolgen. Bei Wandmontagen immer geeignetes Befestigungsmaterial verwenden.
GB US	Furniture must be assembled on a flat surface. For assembly to the wall only use suitable fixing materials.
FR BE NC	Le meuble doit être monté sur une surface plane. Pour le montage mural, utilisez des accessoires de fixation adapté au type de mur.
NL	De meubels dienen op een vlakke ondergrond te worden gemonteerd. Voor wandmontage moeten geschikte bevestigingsmaterialen worden gebruikt.
IT	Il montaggio dei mobili deve avvenire su un fondo piano. Per il montaggio si prega di utilizzare solo materiali adatti.
SI	Pohištvo je treba montirati na ravni podlagi. Pri stenski montaži vedno uporabite pritrditveni material.
XS HR BA	Namještaj se mora montirati na ravnoj podlozi. Kod montaže na zid uvijek koristite prikladan materijal za pričvršćivanje.
HU	A bútorszerelésk sák felületen kell végezni. Falra szereléshez mindig megfelelő rögzítőanyagot kell használni.
BG	Монтажът на мебелите да се извършва на равна основа. При стениен монтаж винаги да се използва подходящ крепежен материал.
CZ SK	Montáž nábytku provádějte na rovném podkladu. Při montáži na stěnu používejte vždy vhodný připevňovací materiál.
PT	A montagem precisa de ser realizada sobre uma superfície plana. Use sempre material de fixação adequado para montagens em paredes.
RO	Montarea mobilei trebuie să se realizeze pe o pardoseală dreaptă. La montarea la perete utilizați întotdeauna material de fixare adecvat.
ES	El montaje debe efectuarse sobre una superficie uniforme. En el montaje mural emplee siempre el material de fijación adecuado.



D CH AT LI LU	Zur Möbelreinigung ein mit Wasser befeuchtetes, fusselfreies Baumwolltuch verwenden. Gereinigte Flächen immer trockenreiben!
GB US	To clean the furniture only use a water dampened lint-free cotton cloth. Once cleaned, always wipe the surfaces dry.
FR BE NC	Utilisez un chiffon en coton non pelucheux humidifié avec de l'eau pour nettoyer les meubles. Séchez systématiquement les surfaces nettoyées en les frottant !
NL	Gebruik een met water bevochtigde, pluivrije katoenen doek om de meubels te reinigen. Wrijf gereinigde oppervlakken altijd droog!
IT	Per pulire il mobile utilizzare un panno di cotone inumidito d'acqua e che non perde pelucchi. Asciugare sempre le superfici che si sono pulite!
SI	Za čiščenje pohištva uporabljajte vlažno bombažno krpo, ki ne pušča vlaken. Očiščene površine vedno obrišite do suhega!
XS HR BA	Za čišćenje namještaja koristite sa vodom navlaženu pamučnu krpu koja ne ispušta vlakna. Očiščene površine uvijek obrišite suhom krpom!
HU	Bútortisztításhoz vízzel benedvesített, nem szálazódó pamutkendőt használjon. A megtisztított felületeket mindig törölje szárazra!
BG	За почистване на мебелите използвайте навлажнена с вода, неизпускаща влакна памучна кърпа. Почистените повърхности винаги да се изтриват до сухо!
CZ SK	K čištění nábytku používejte bavlněný hadr neuvolňující vlákna, navlhčený ve vodě. Vyčištěné plochy vždy utřete do sucha!
PT	Para limpar os móveis, use um pano de algodão que não largue pelo, humedecido com água. Seque sempre bem as superfícies limpas com um pano!
RO	Pentru curățarea mobilei utilizați o lavetă din bumbac fără scame umezită cu apă. Suprafețele curățate se șterg întotdeauna până se usucă!
ES	Emplee un paño de algodón humedecido con agua y libre de pelusa para la limpieza de los muebles. ¡Seque siempre las superficies que ha limpiado!



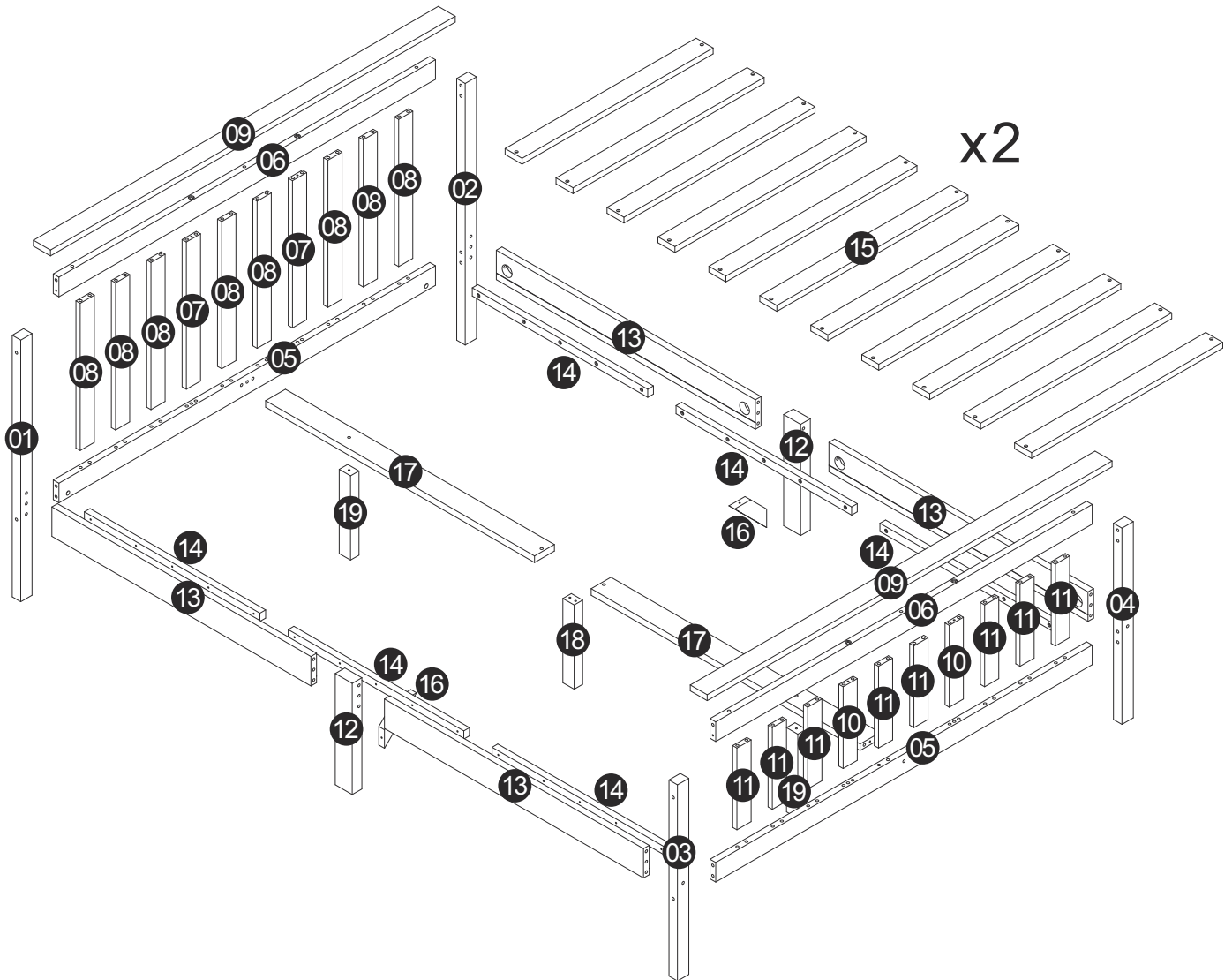



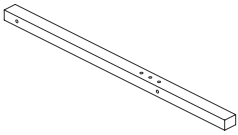
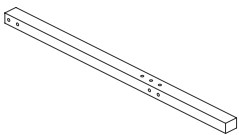
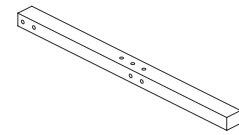
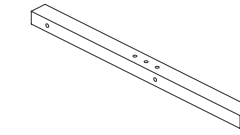
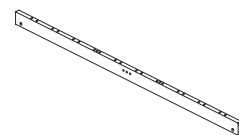
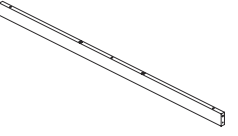
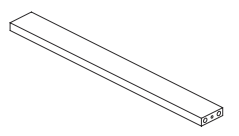
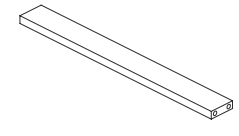
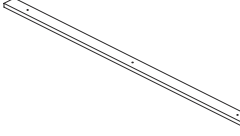
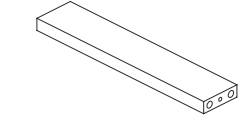
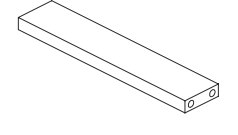
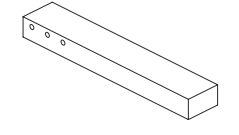
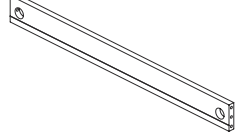
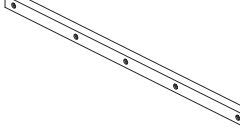
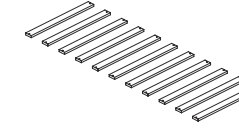
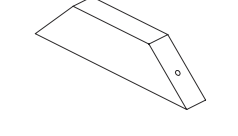
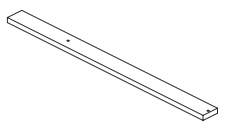
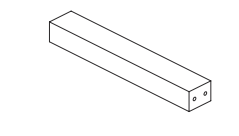
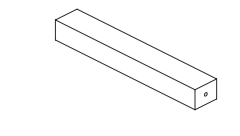

DETAIL VIEW

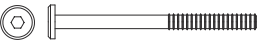

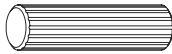
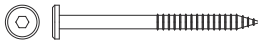
Wf038854

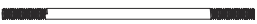

01 x1 	02 x1 	03 x1 	04 x1 	05 x2 
06 x2 	07 x2 	08 x8 	09 x2 	10 x2 
11 x8 	12 x2 	13 x4 	14 x6 	15 x2 
16 x2 	17 x2 	18 x1 	19 x2 	

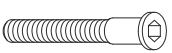
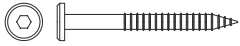
Hardware List WF038854

A x4  M6x90	B x4 	C x108  Φ8x30	D x12  Φ6x90	F x10  M6x70
G x2  M6x140	H x8 	J x78  Φ4x30	K x2 	L x1 
M x4  Φ7x50	N x2  Φ6x70			

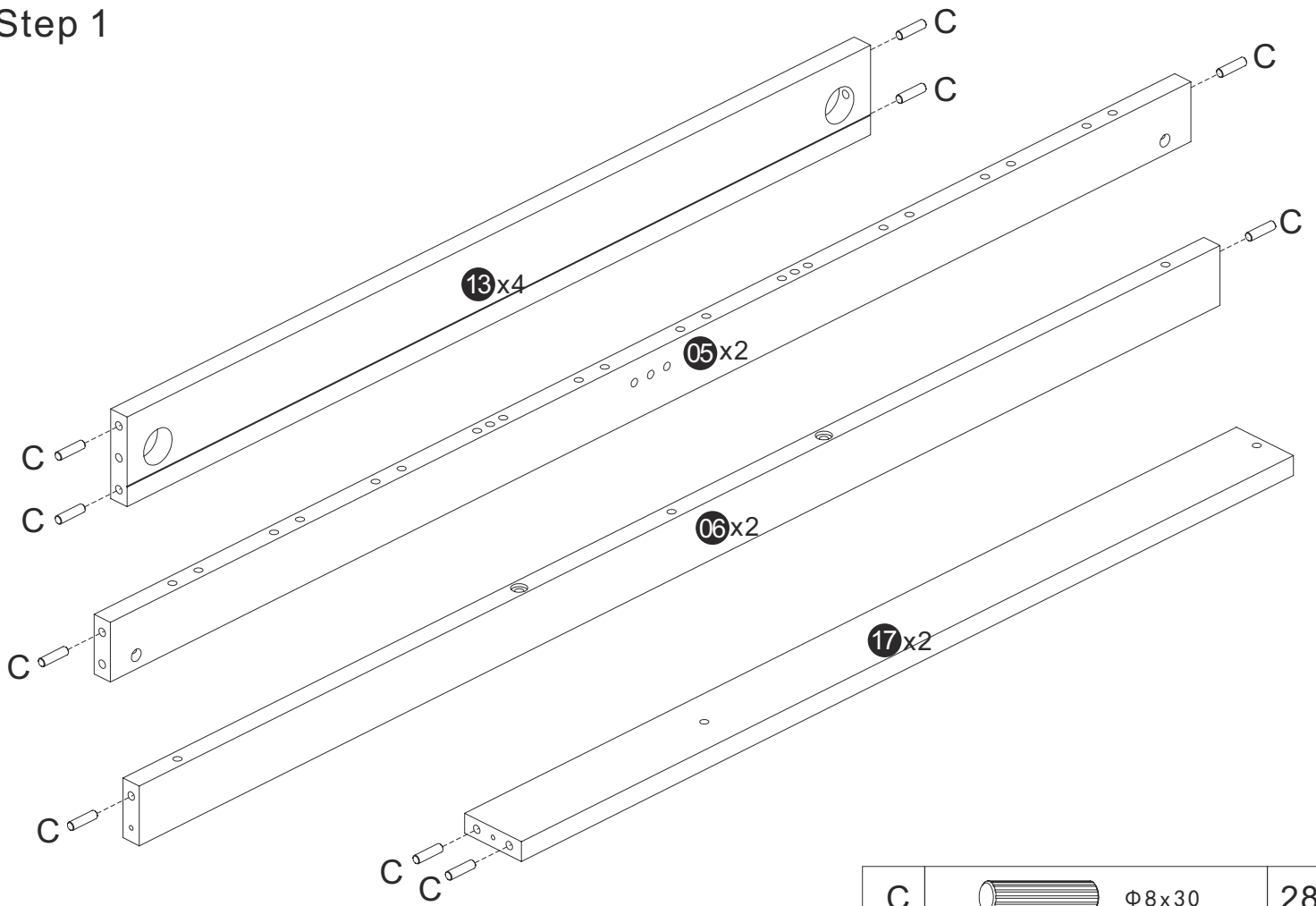
Step 1

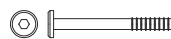

C		Φ 8x30	28
C		Φ 8x30	80
D		Φ 6x90	8

Step 2

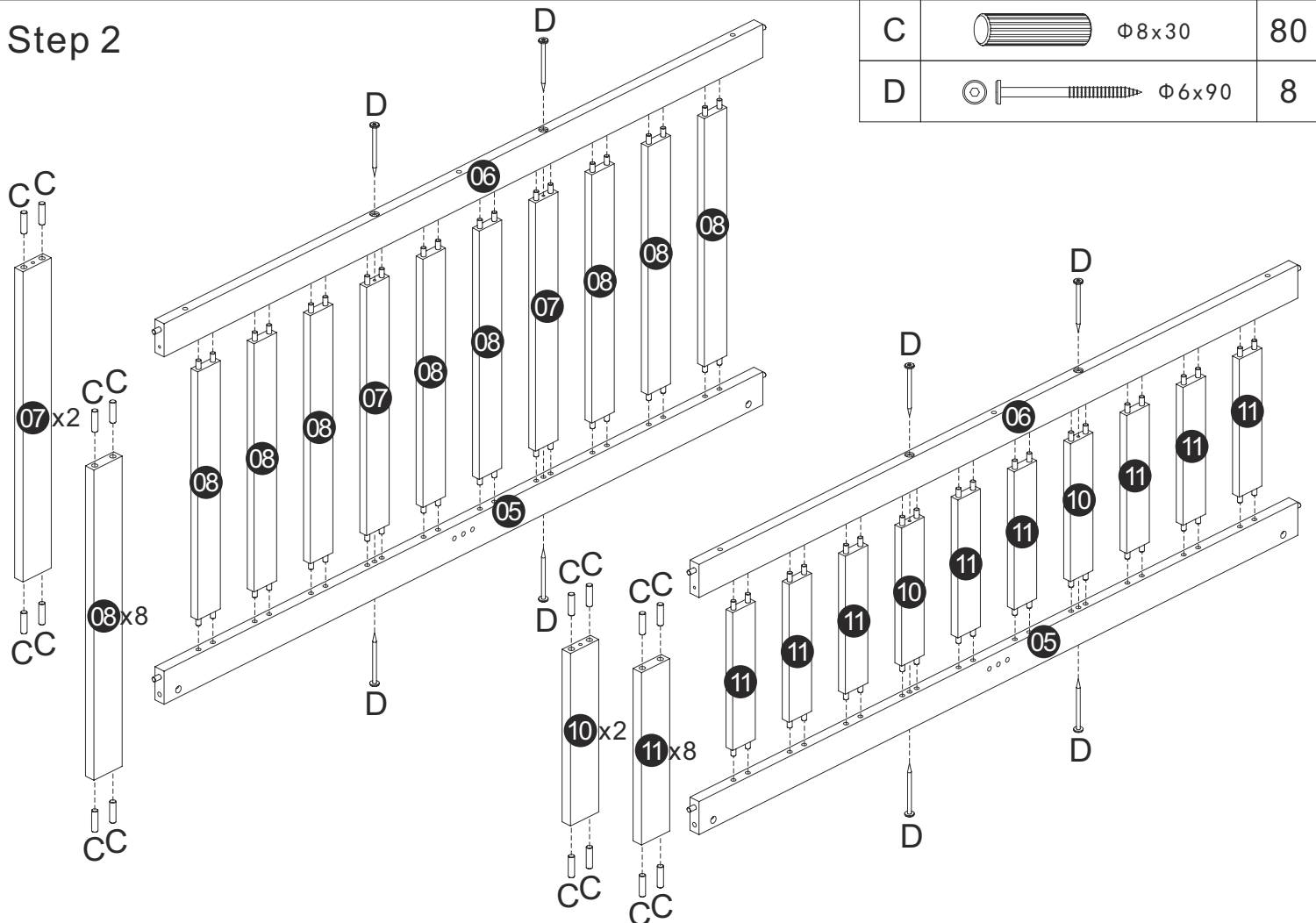



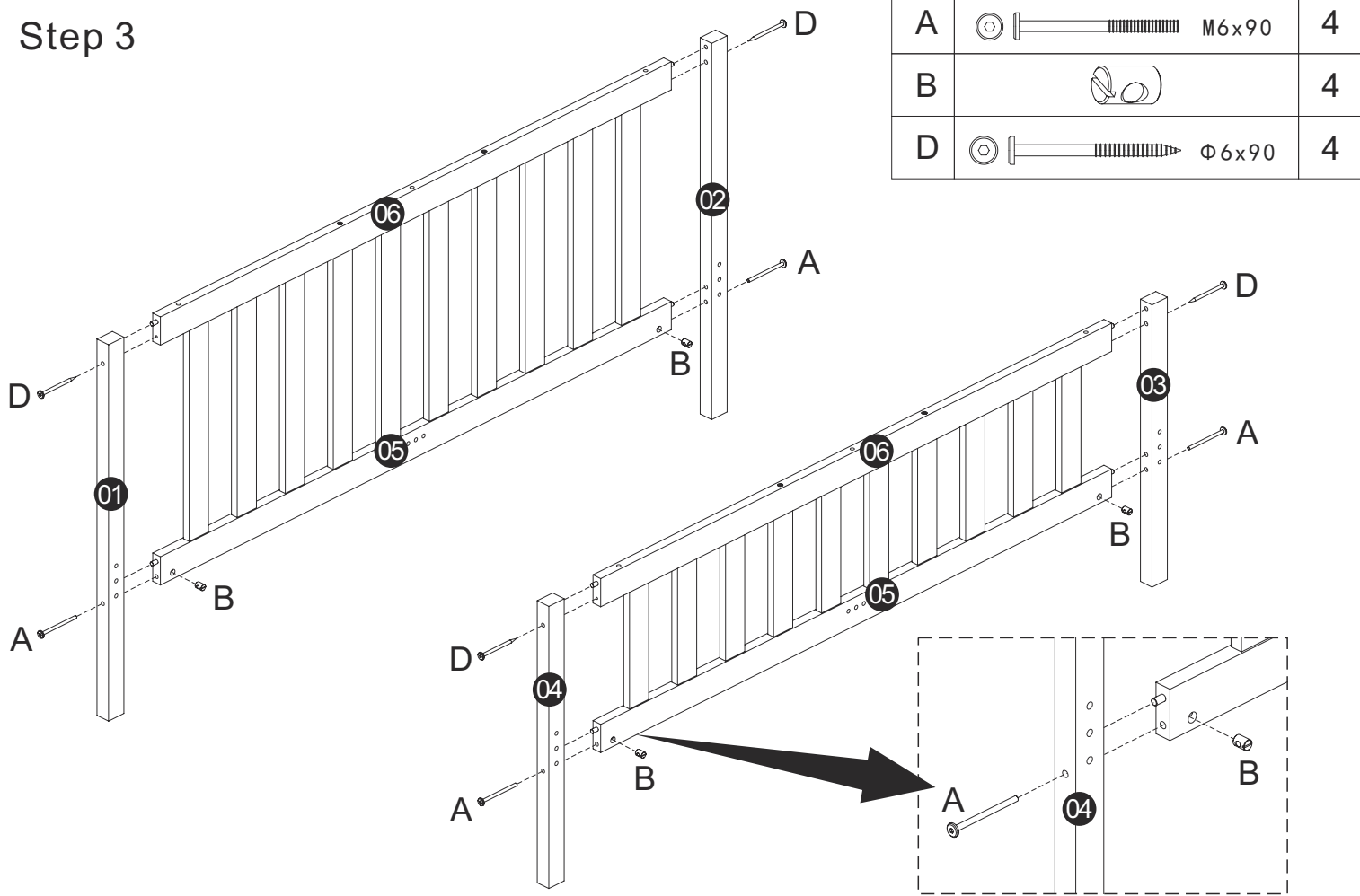

Step 3

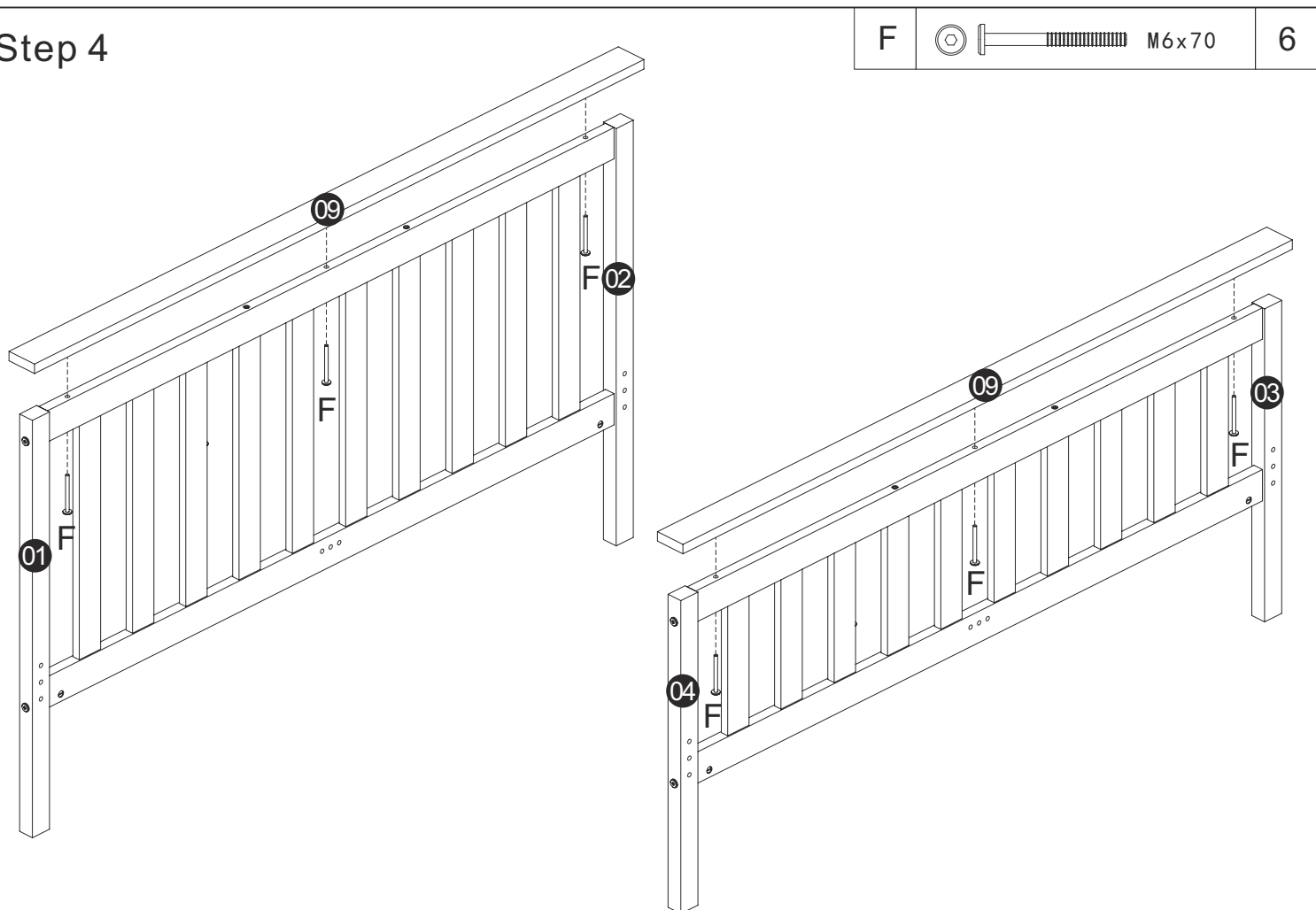

Step 4

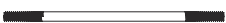

Step 5

G	 M6x140	2
H	  	4
K		2

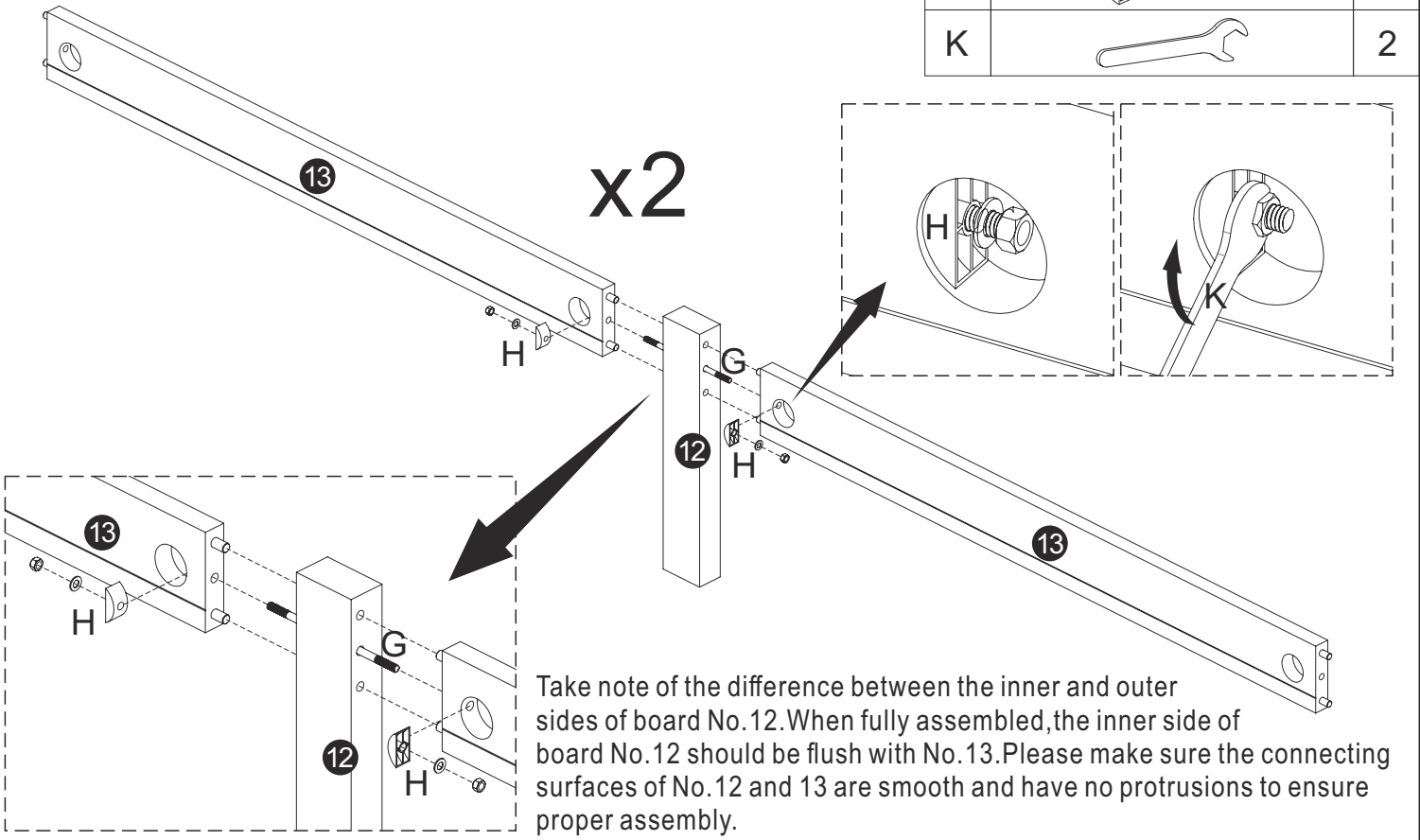

Step 6

J	 $\Phi 4 \times 30$	30
---	--	----

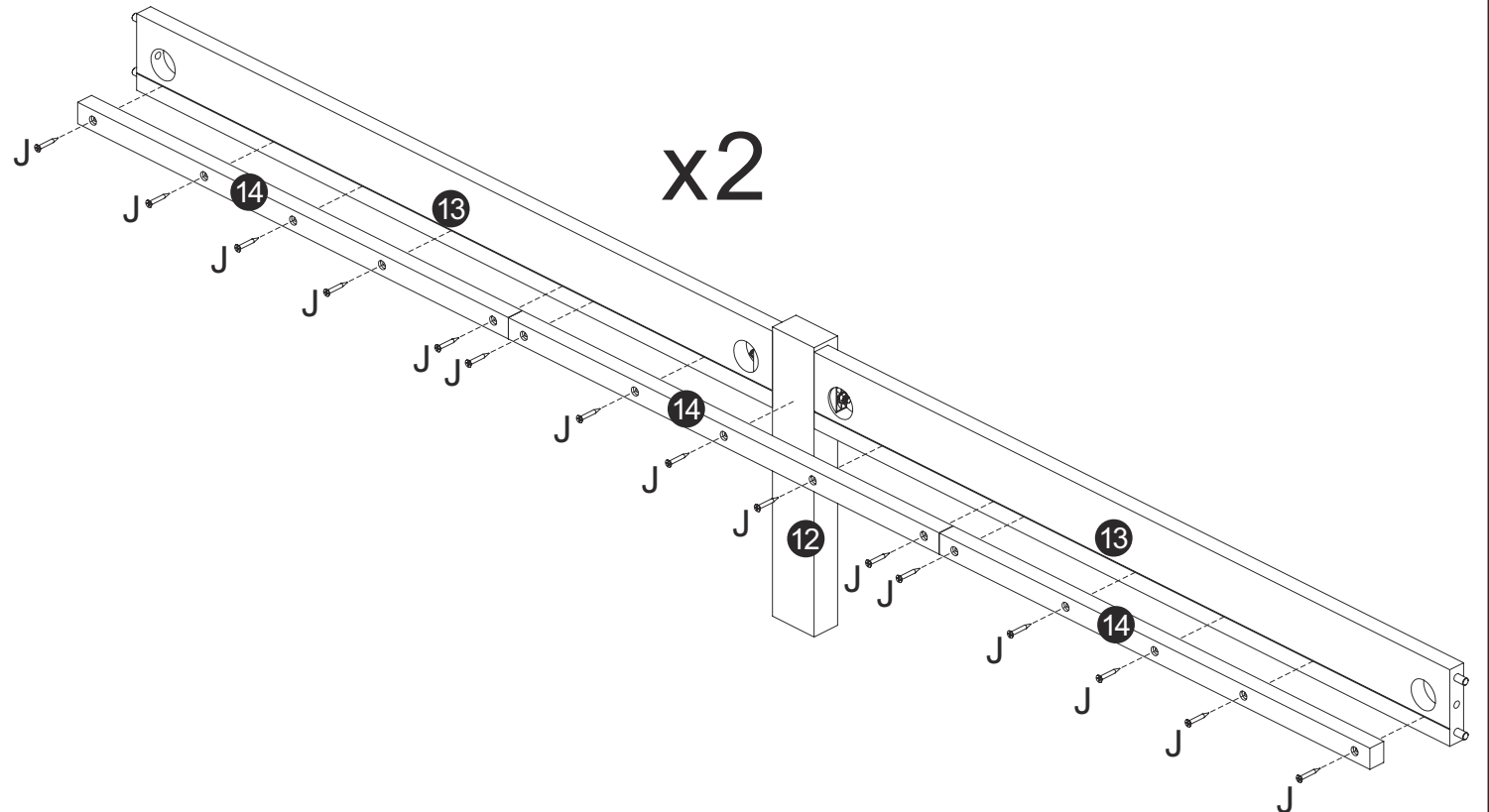

Step 7

M



Φ7x50

4

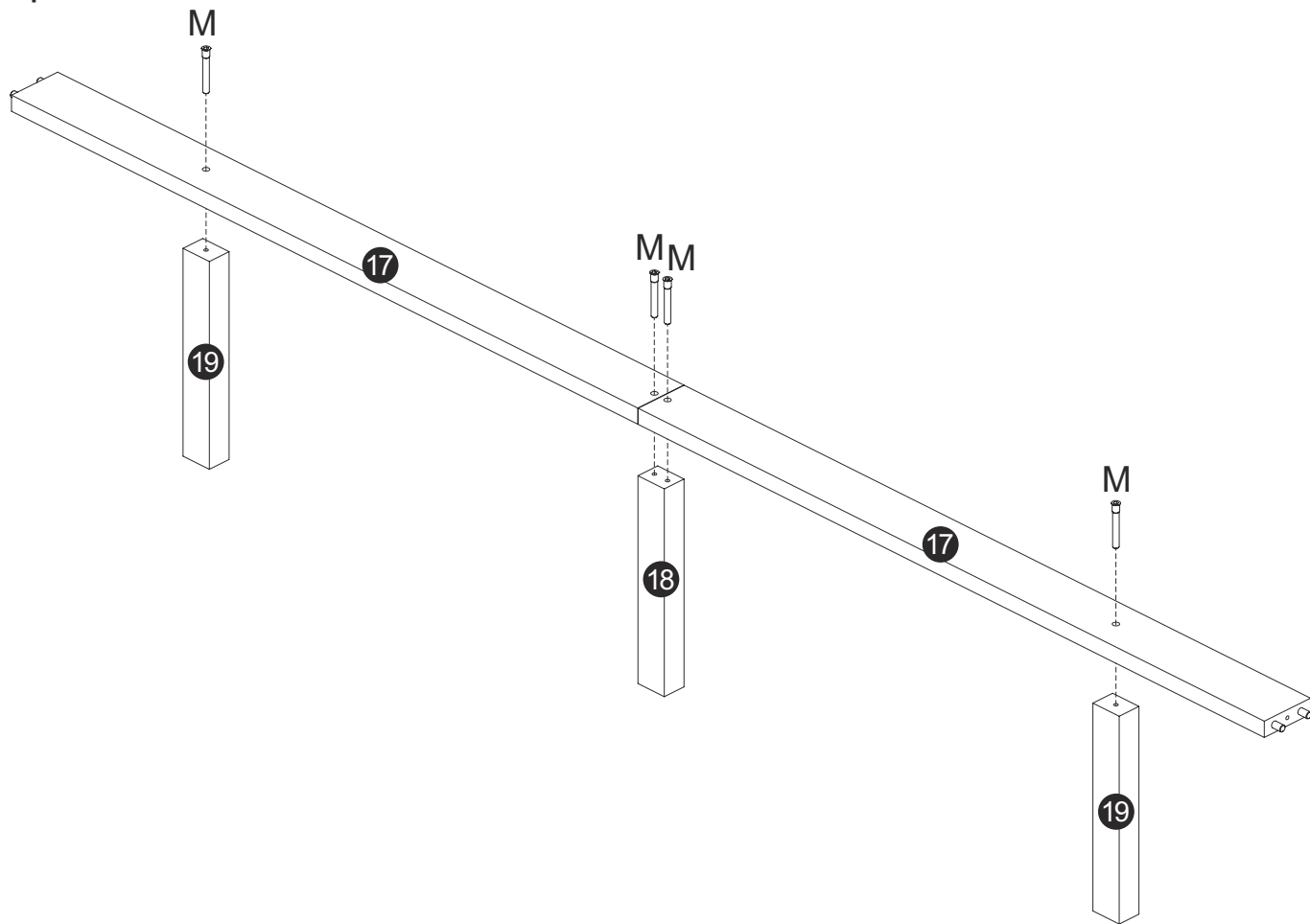

Step 8

F

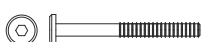

M6x70

4

K



1

H



4

N



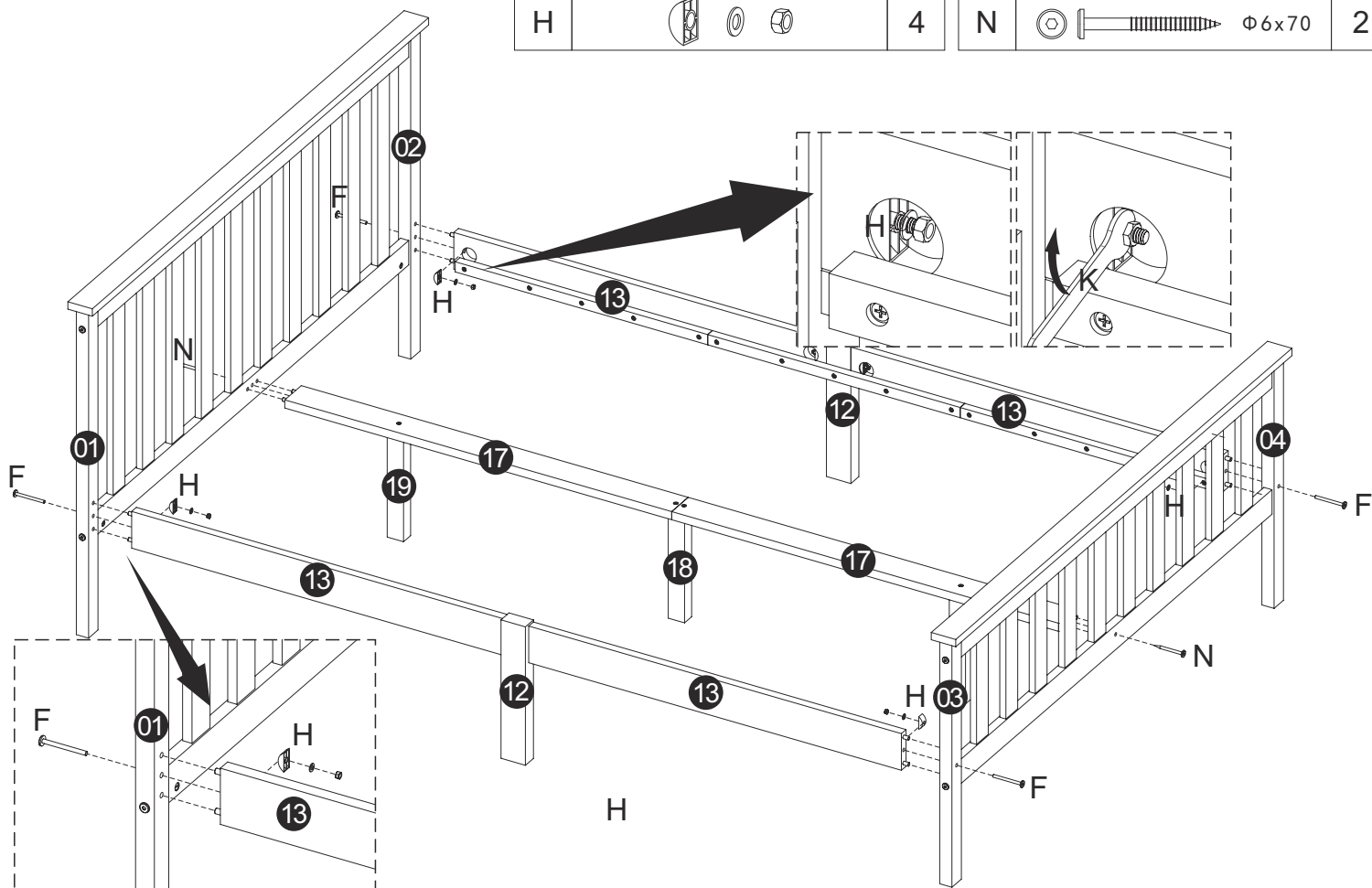

2



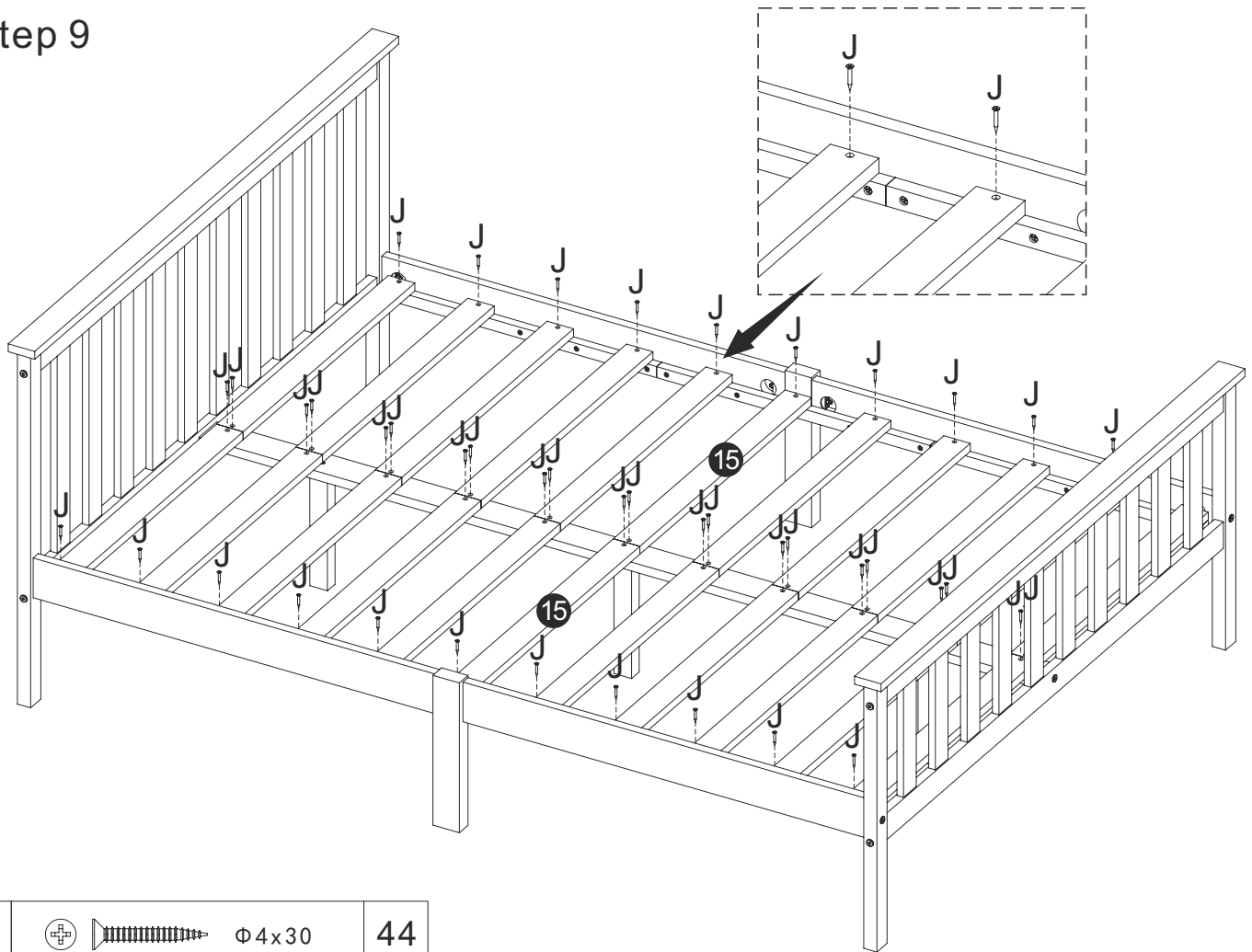

Step 9



J			Φ4x30	44
---	---	---	-------	----

Step 10

J			Φ4x30	4
---	---	---	-------	---

