

# 2 DRAWER COFFEE TABLE

Assembly Instructions – Please keep for future reference

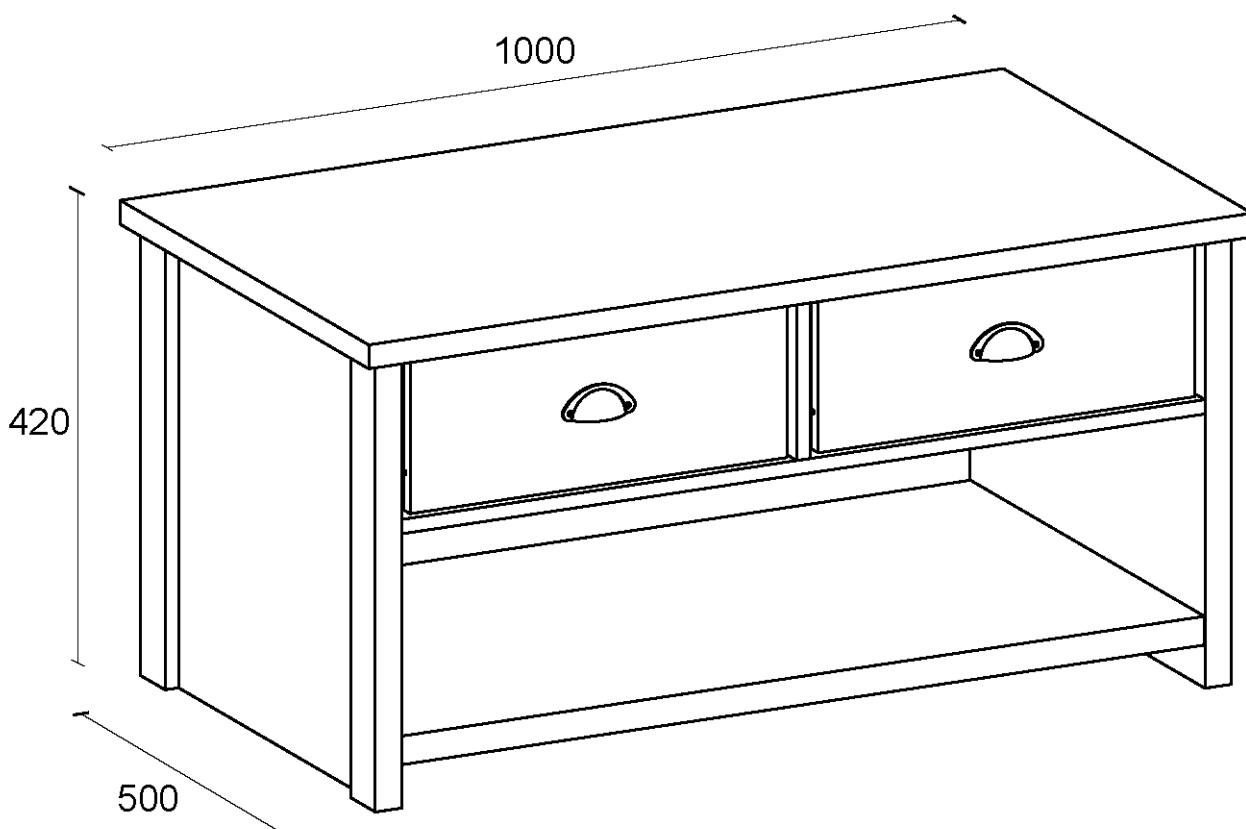

Dimensions	No. people	Assembly Time
Width: 100cm Depth: 50cm Height: 42cm		45 mins (approx.)

### Important

- PLEASE READ THESE INSTRUCTIONS FULLY BEFORE STARTING ASSEMBLY
- PLEASE DO NOT THROW THE PACKAGING AWAY UNTIL YOU ARE SATISFIED WITH PURCHASE, GOODS NEED TO BE RETURNED IN ORIGINAL PACKAGING.

# ⚠ Safety and Care Advice

**Important** – Please read these instructions fully before starting assembly

- Check you have all the components and tools listed on pages 4 and 5.
- Remove all fittings from the plastic bags and separate them into their groups.
- Keep children and animals away from the work area, small parts could choke if swallowed.
- Make sure you have enough space to lay out the parts before starting.
- Do not stand or put weight on the product, this could cause damage.
- Assemble the item as close to its final position (in the same room) as possible.
- Assemble on a soft, level surface to avoid damaging the unit or your floor.
- We do not recommend the use of power drill/drivers for inserting screws, as this could damage the unit. Only use hand screwdrivers.
- Dispose of all packaging carefully and responsibly.



use of power drill/drivers for inserting screws, as this could damage the unit.

Only use hand screwdrivers.

- Dispose of all packaging carefully and responsibly.

## Care and Maintenance

- Only clean using a damp cloth and mild detergent, do not use bleach or abrasive cleaners.
- From time to time check that there are no loose screws on this unit.
- This product should not be discarded with household waste. Take to your local authority waste disposal centre.

## SPECIAL TIPS FOR FITTING CAM-LOCKS AND QUICKFIT

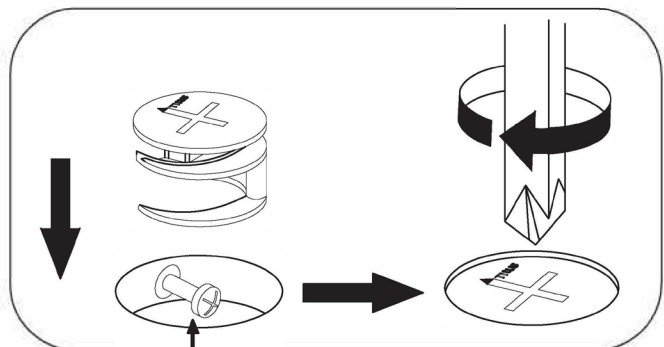
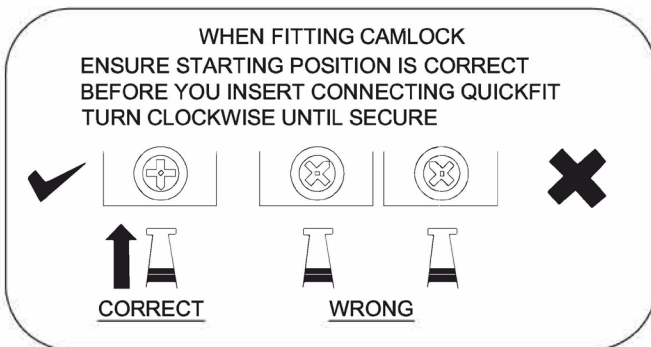

**Quickfit head needs to be in centre**

### QUICKFIT

**Tighten until shoulder is flush with panel. Do not overtighten or undertighten (see example below)**

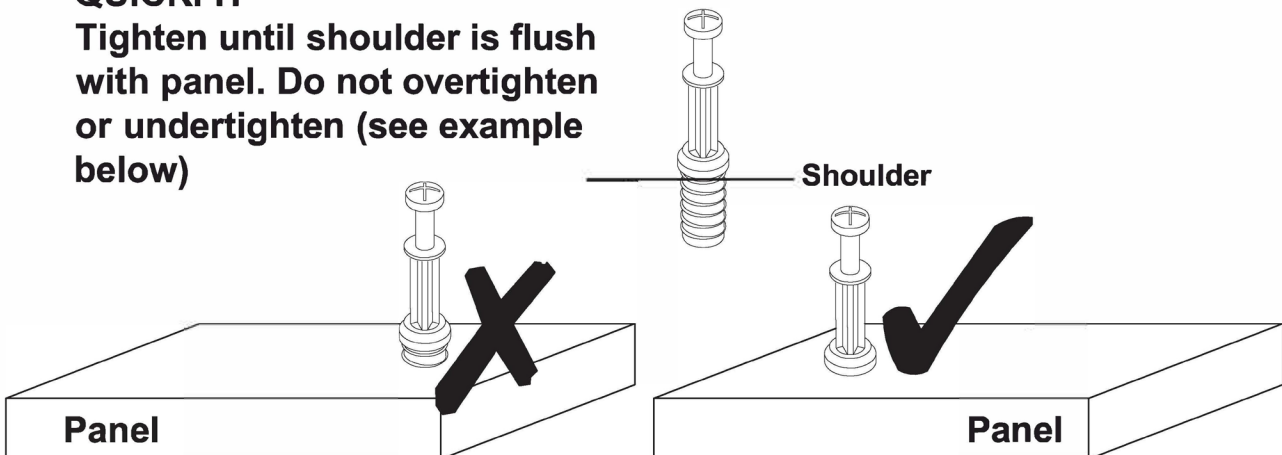

**If you are unhappy with the product and wish to return it, please follow the retailer's returns procedure.**

# Exploded View

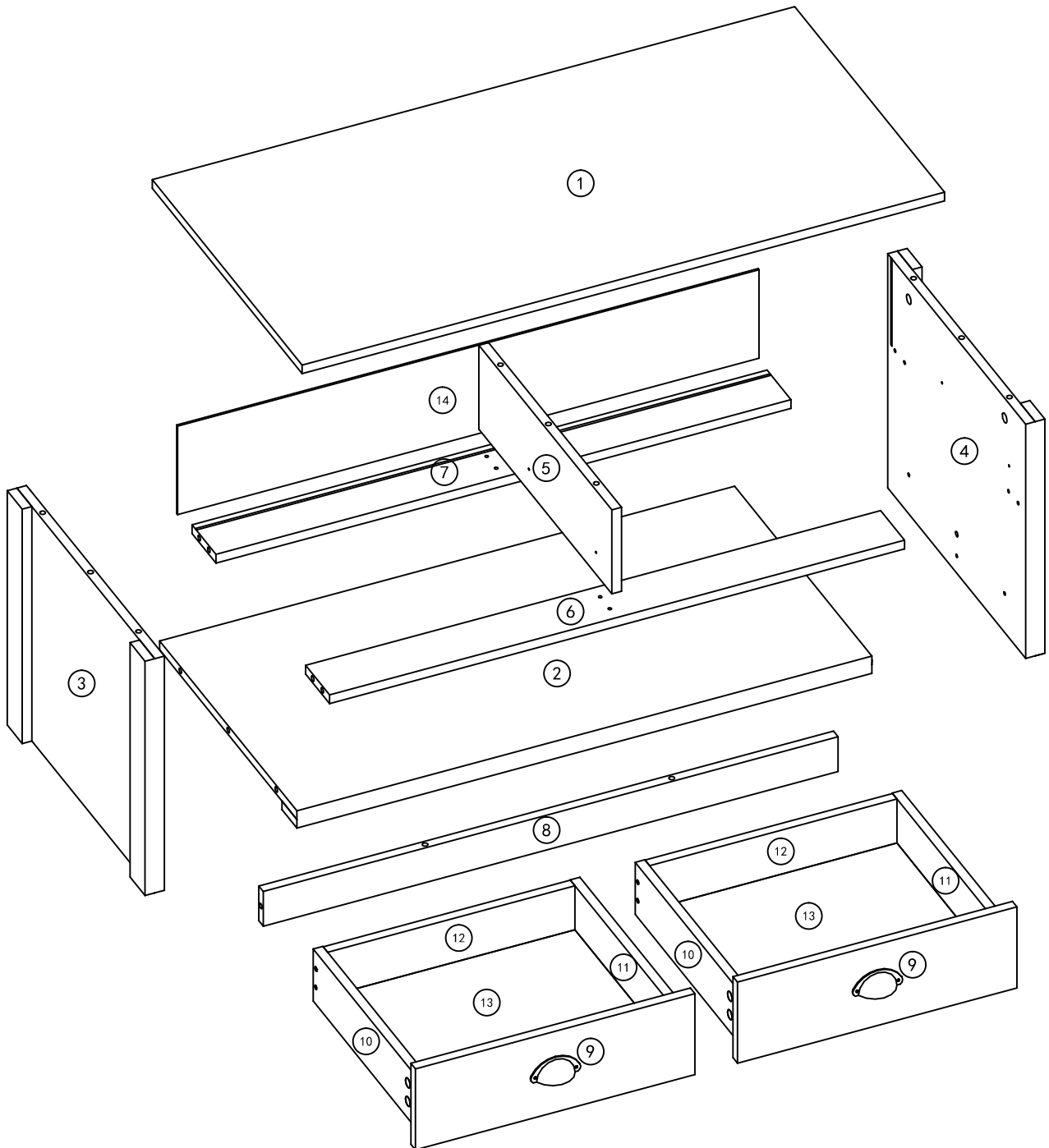







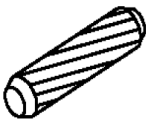

# Components - Fixings

**Please check that you have all the components listed below before constructing your item.**

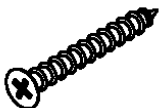
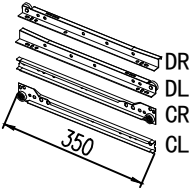
**Note:** The quantities below are the correct amount to complete the assembly. In some cases more fittings may be supplied than are required.

(A) X28	 40mm	(B) X28	 15*11mm	(C) X7	 8*40mm	(D) X2	
(E) X16	 3.5*14 mm	(F) X12	 3.5*35 mm	(G) X2		(H) X5	

## Tools Required

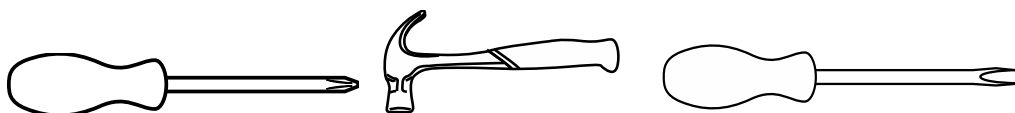

**Ruler – Use this to measure your screws (mm)**

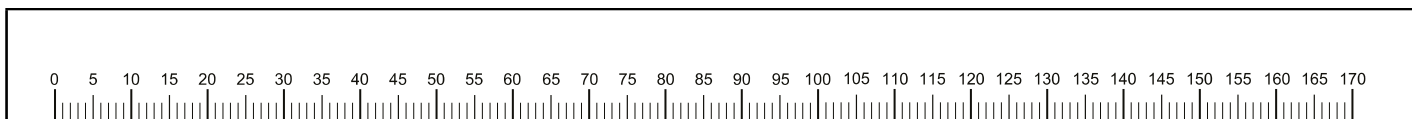

**Important – Please read these instructions fully before starting assembly**

# Assembly Instructions

1

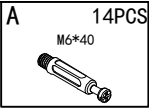
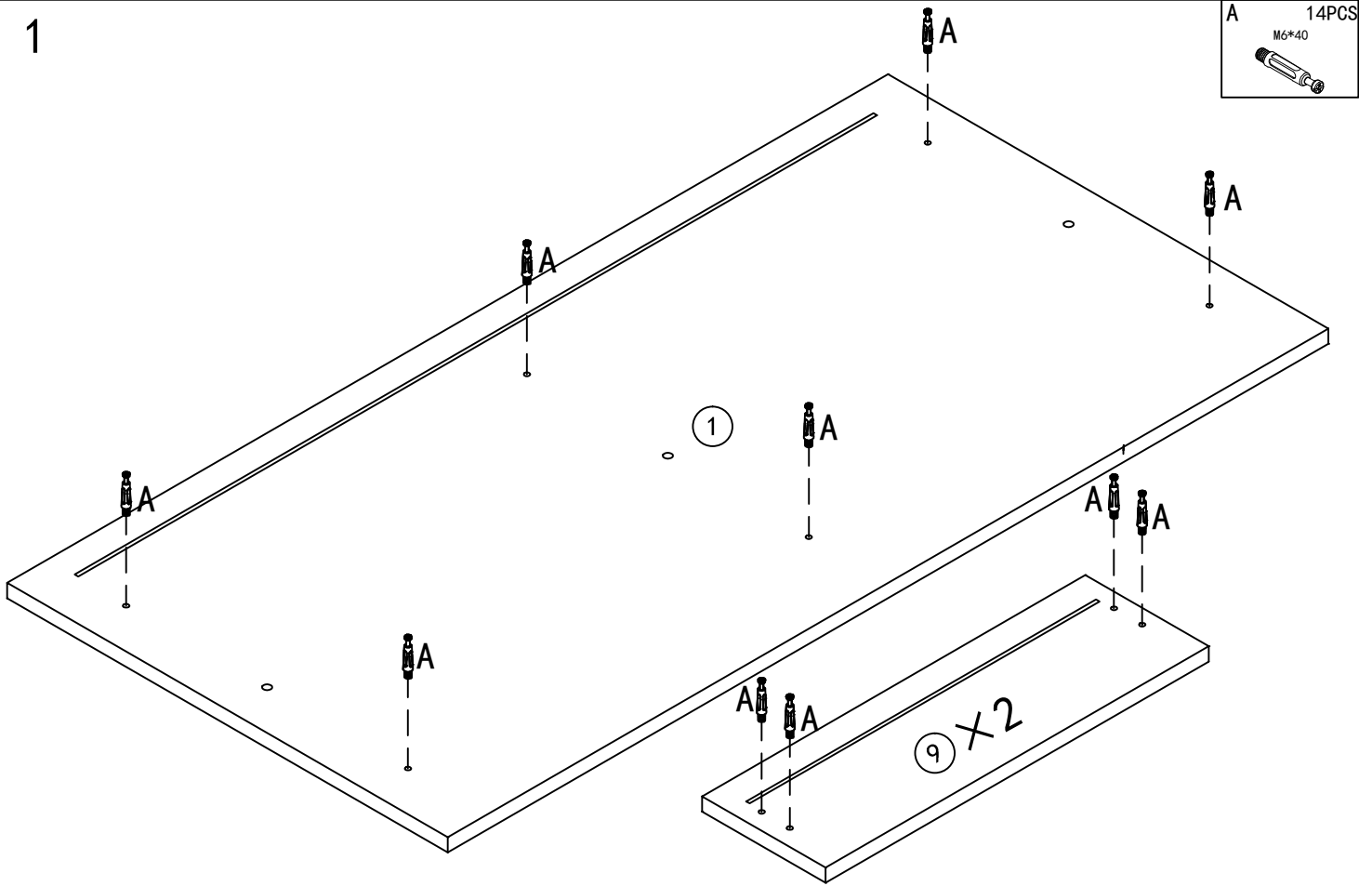

2

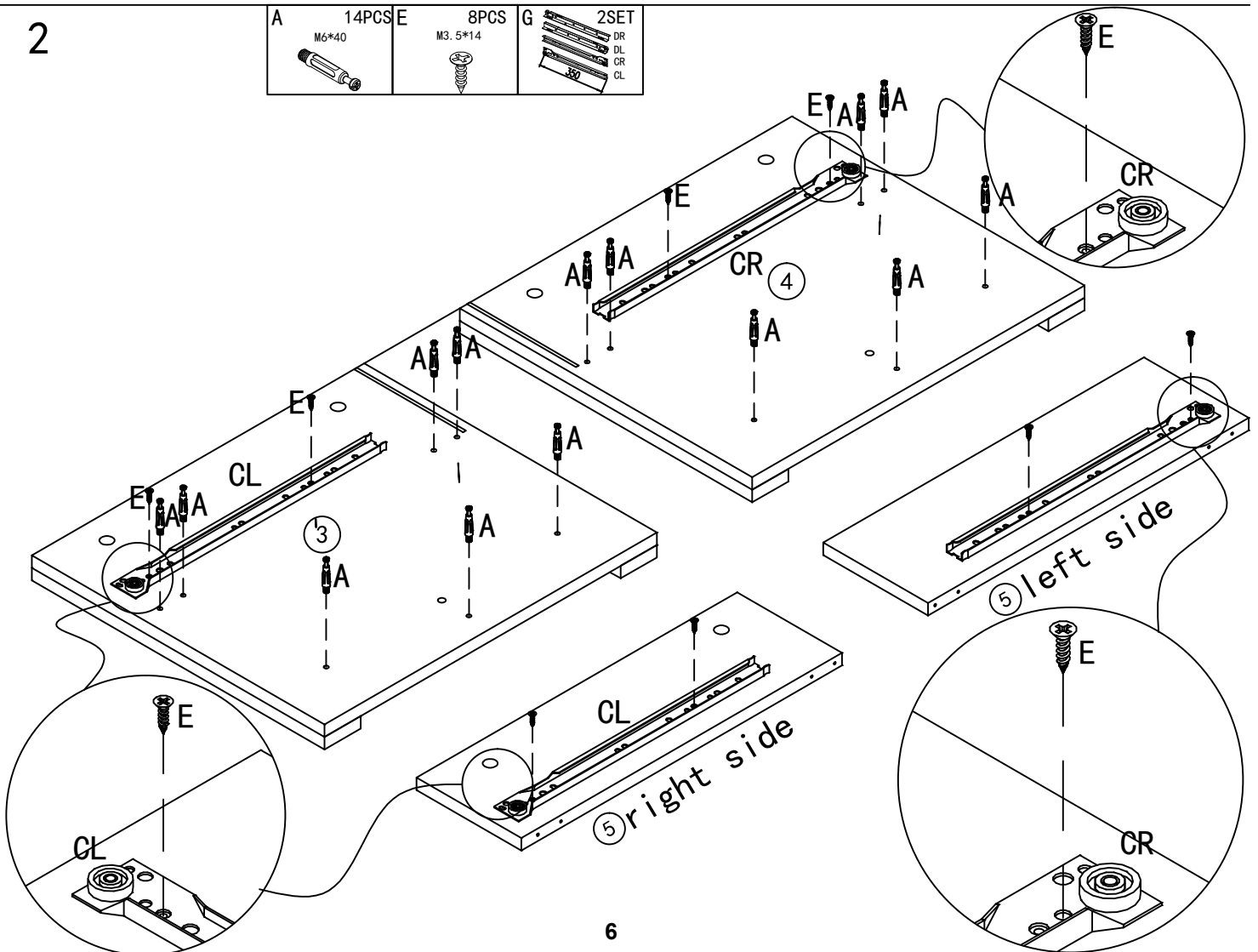
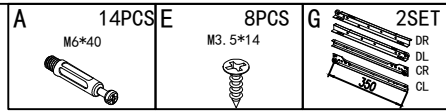



6

3

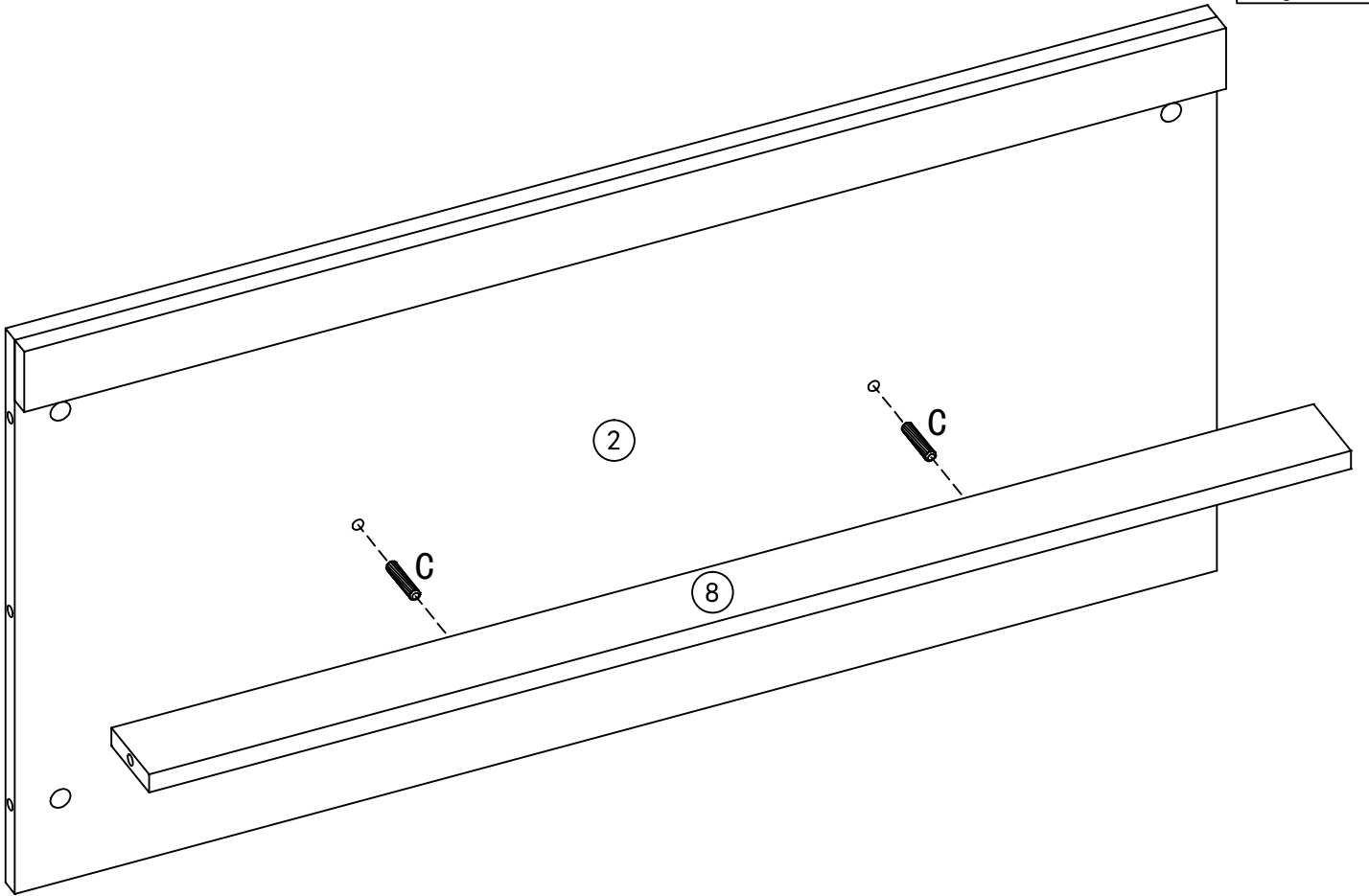
C 2PCS  
Φ8\*40



4

B	14PCS	C	2PCS
	M15*11		Φ8*40
			

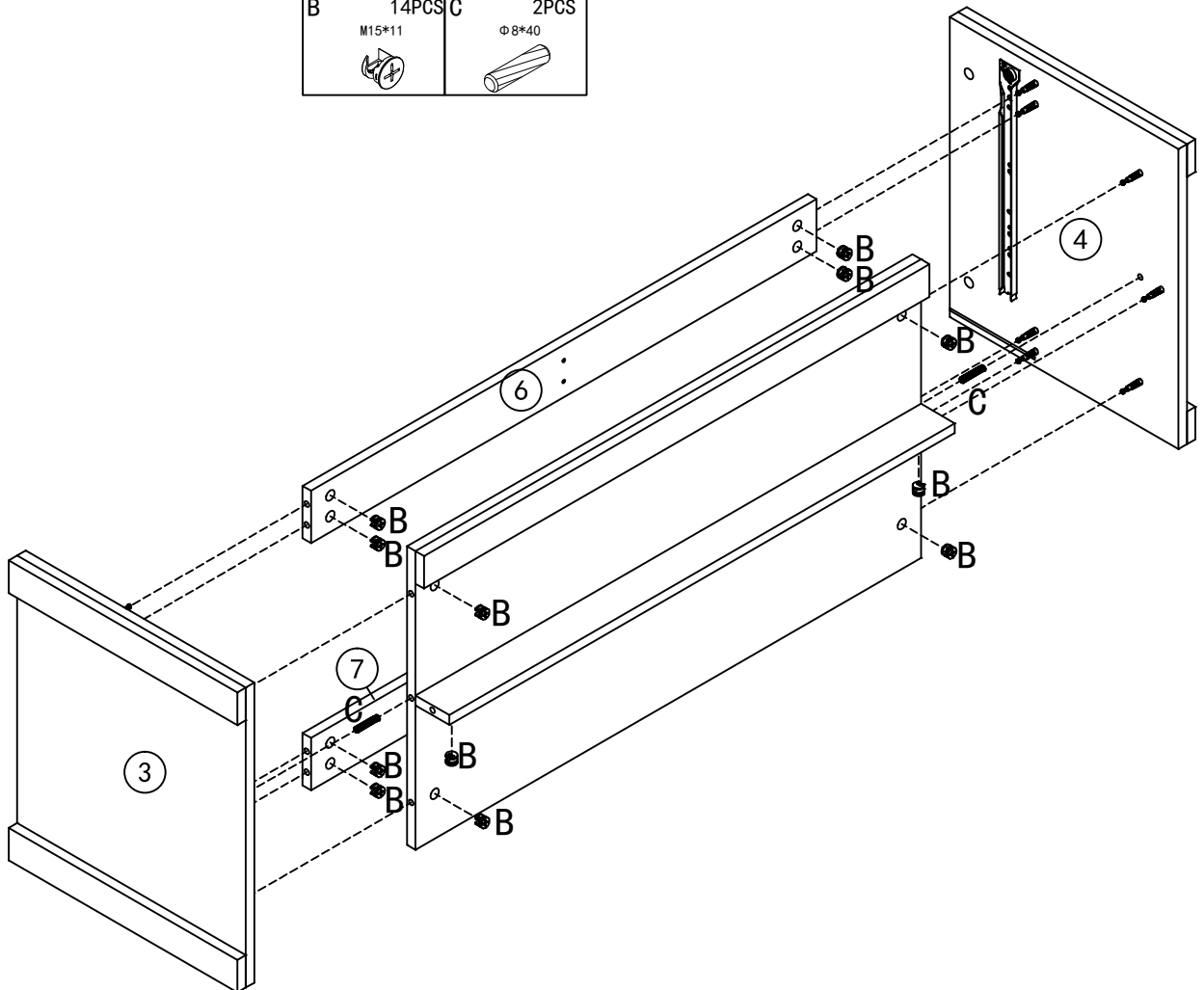

5

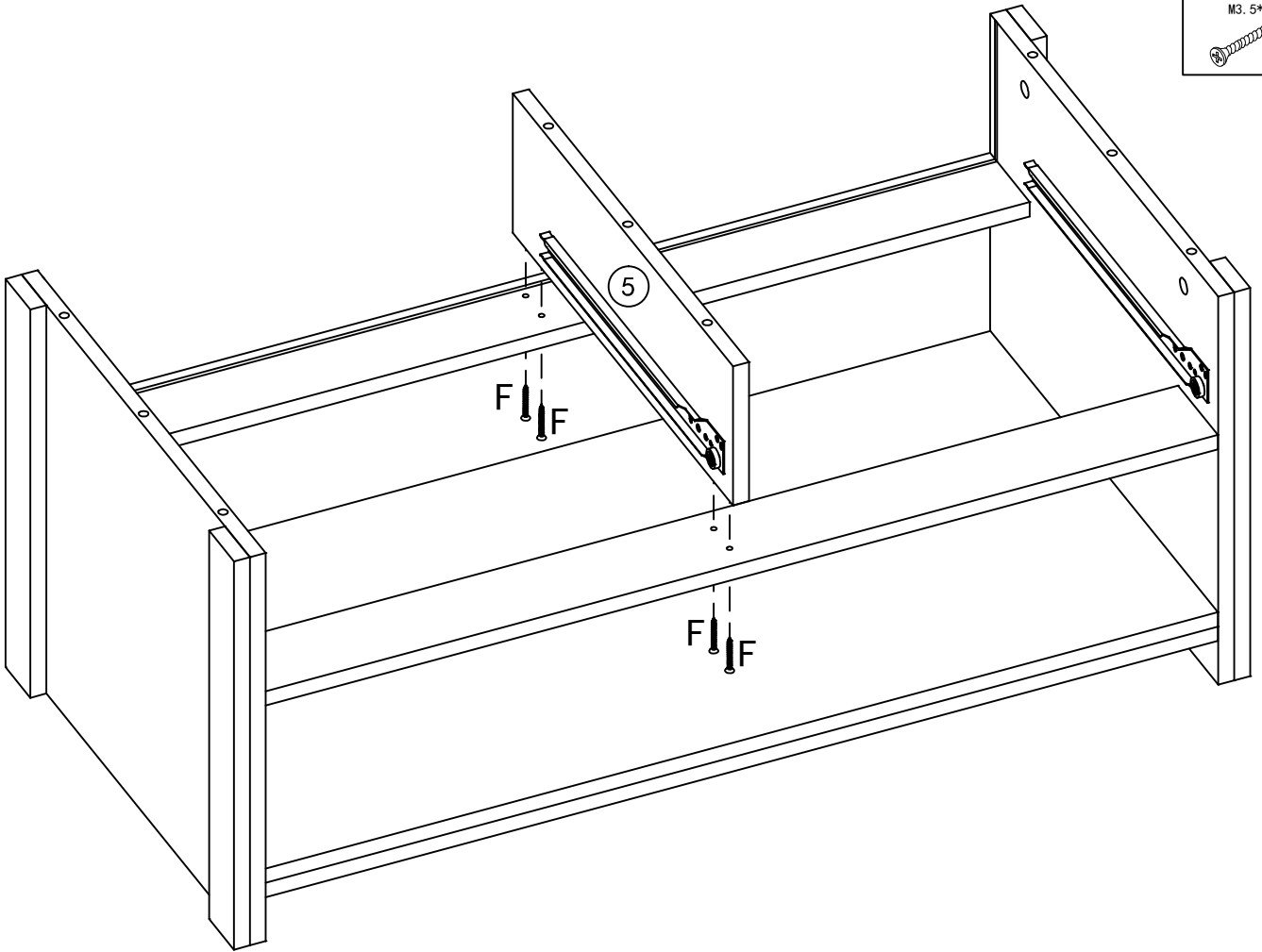

F 4PCS  
M3. 5\*35

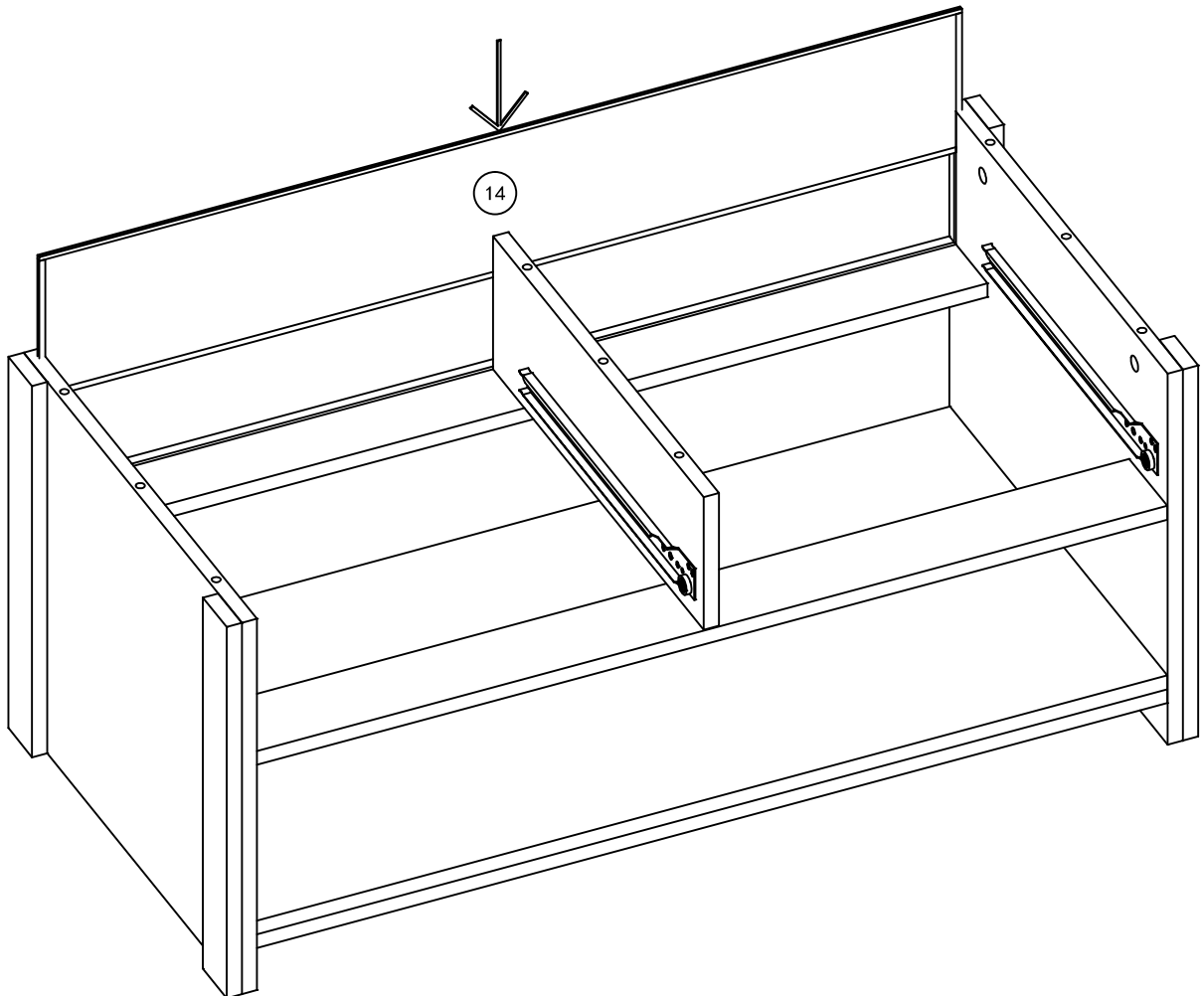

6



7

<b>B</b>	6PCS	<b>C</b>	3PCS
	M15*11		Φ8*40
			

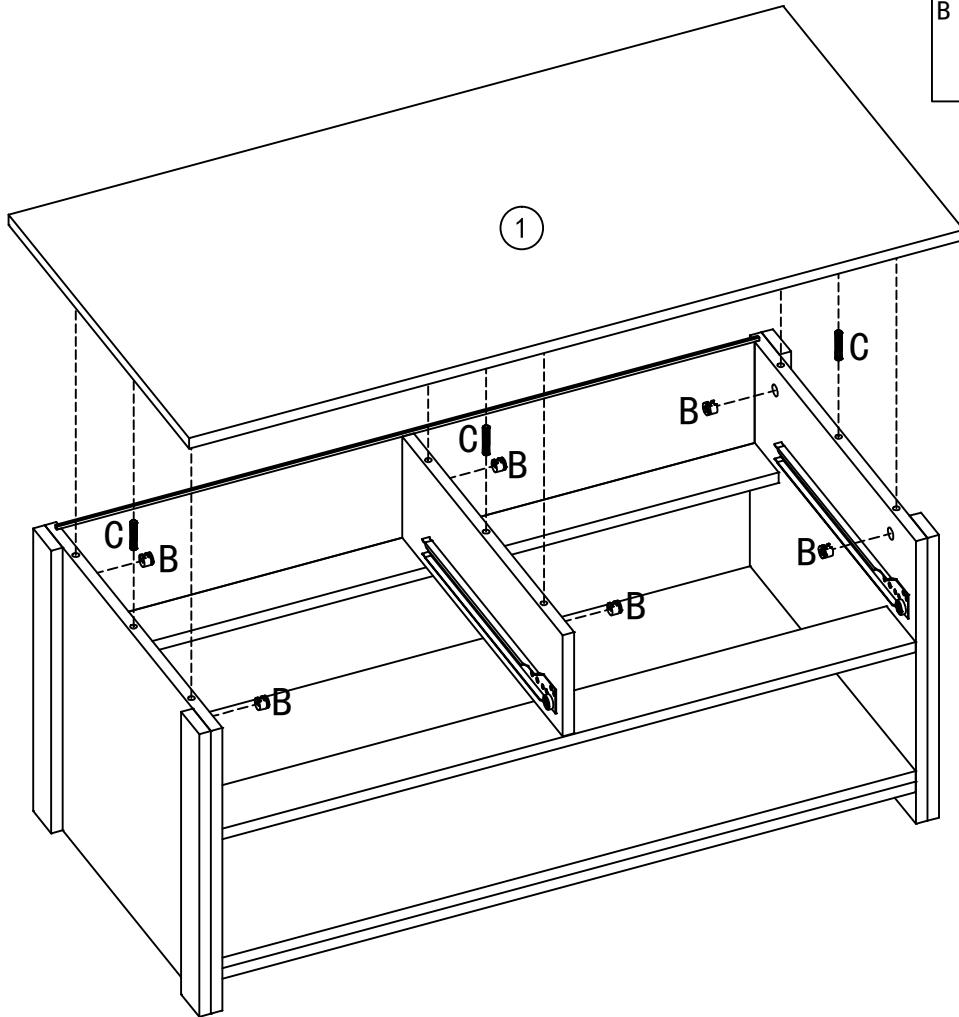

8

<b>H</b>	5PCS
	

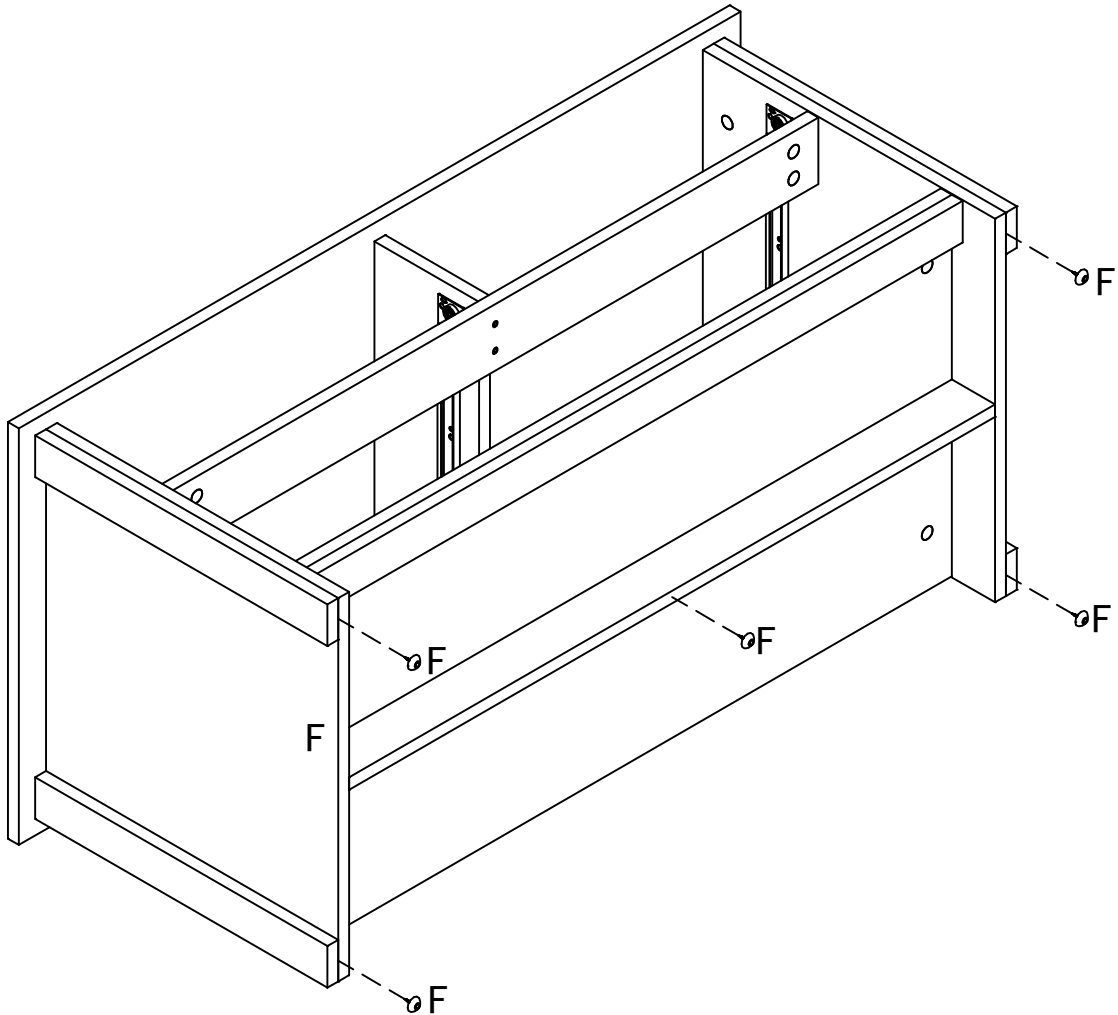

9

9

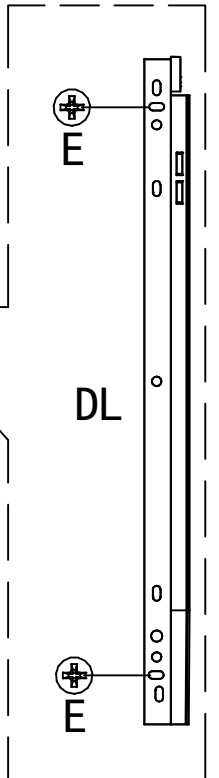
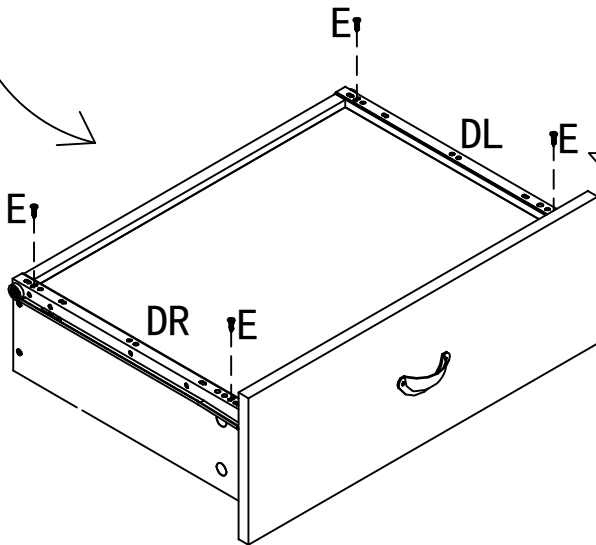
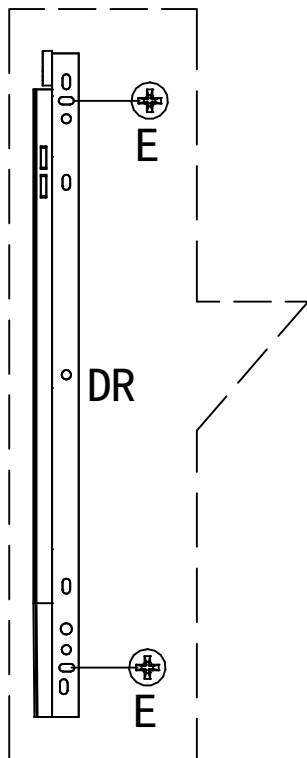
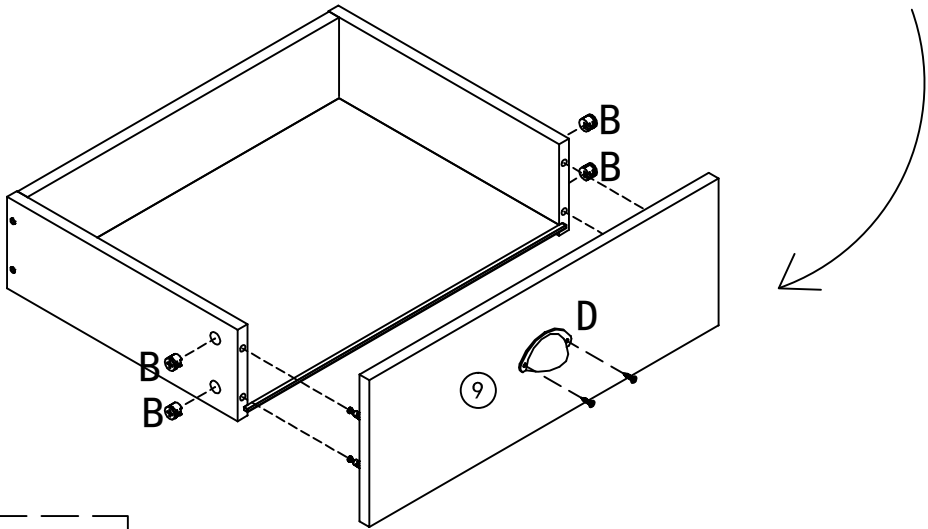
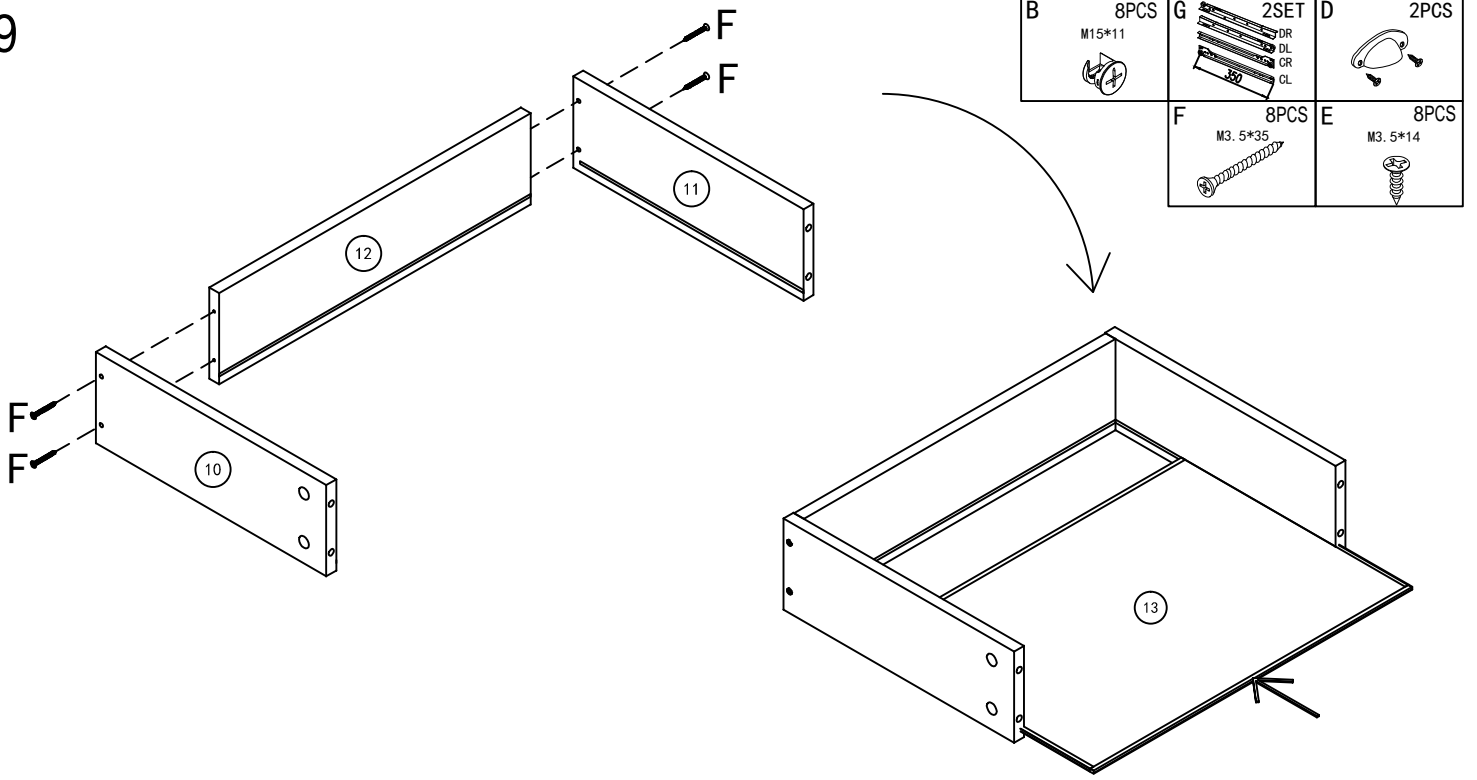

X2

