

ASSEMBLY INSTRUCTION

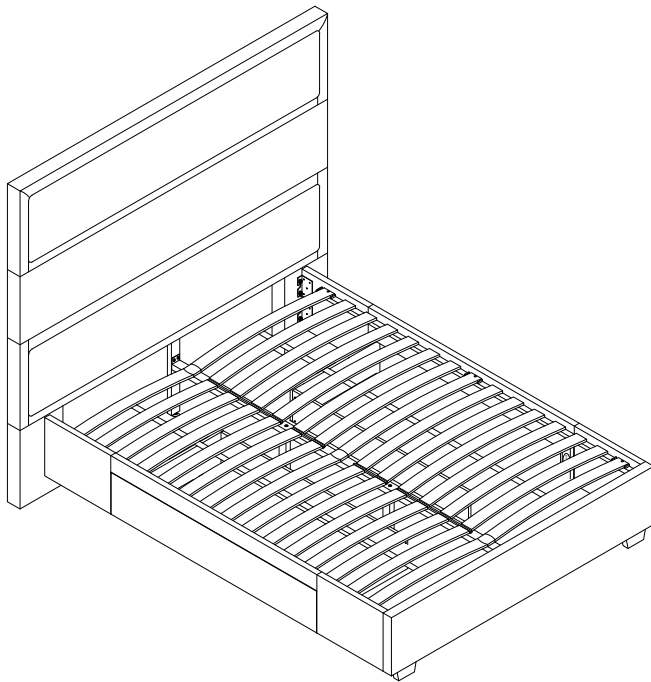

Please **TEAR OFF** this shrink film from side!
DO NOT USE CUTTER!

IMPORTANT NOTE

1. **The product is shipped in two packages. Please check the number of packages received before assembly. If you are missing one package, receive a duplicate package, or have any assembly or after-sales issues, please contact us.**
2. For the protection of your furniture, place all parts on a clean and smooth surface to prevent any damage.
3. Keep fittings out of children's reach and keep children well away from construction area.
4. When moving your assembled bed, it is best to lift the bed and never to drag it.
5. Do not use this product if parts are missing, damaged or worn.
6. This product should only be used on firm, level ground.
7. Please periodically check all fittings and re-tighten as necessary.
8. Do not use the bed unless all bolts and screws are firmly secured.
9. For further assistance, please provide a screenshot of your order and contact us.

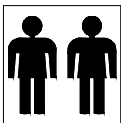

Minimum two
person assembly

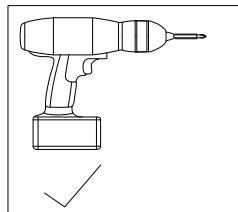

PART LIST

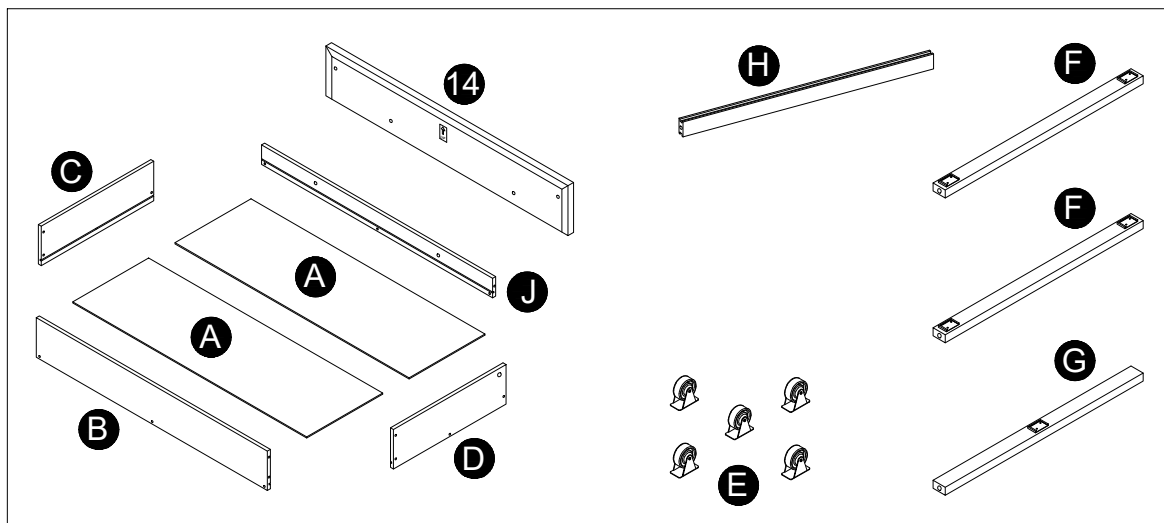
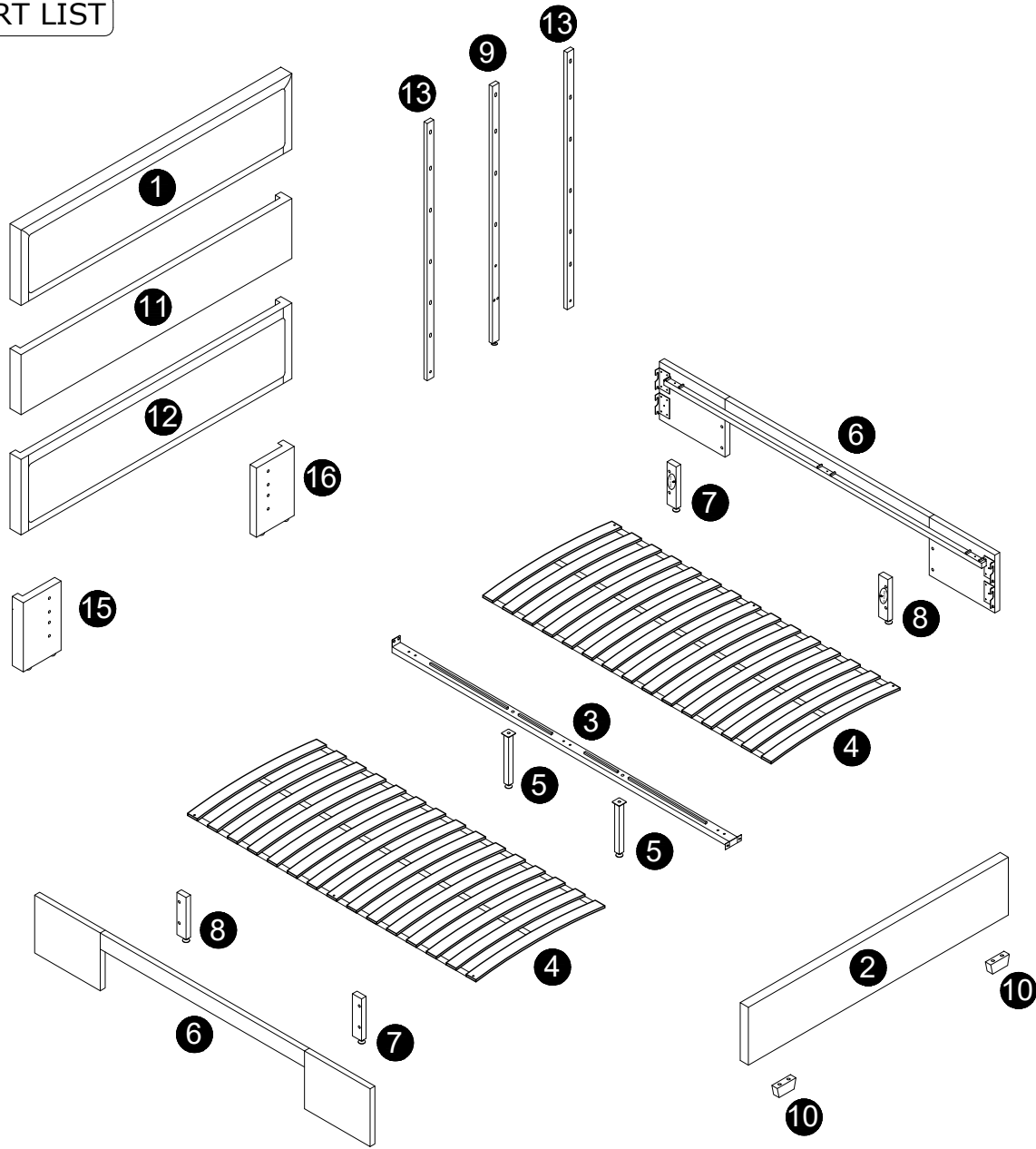

x2

Components of Carton A

1 x 1pc

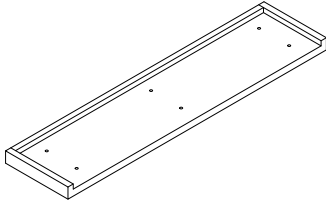

4 x 2pcs

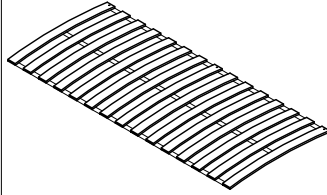

9 x 1pc



11 x 1pc

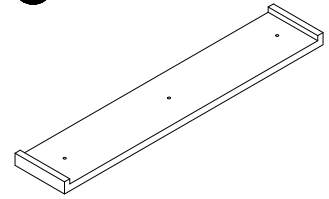

12 x 1pc

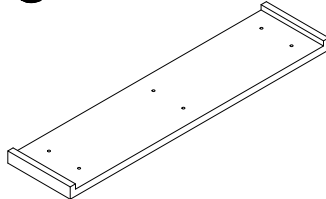

13 x 2pcs



15 x 1pc

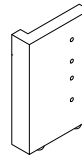

16 x 1pc

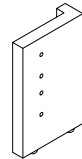

A x 4pcs

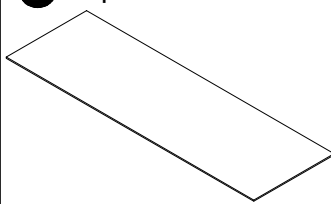

C x 2pcs

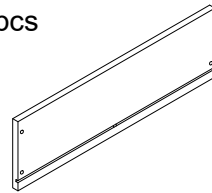

F x 4pcs

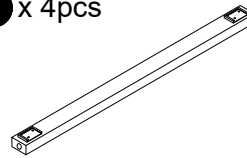

G x 2pcs

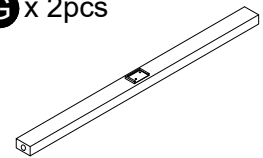

H x 2pcs

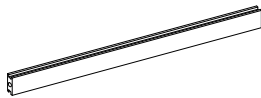

J x 2pcs

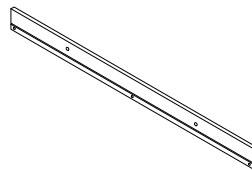

Components of Carton B

2 x 1pc

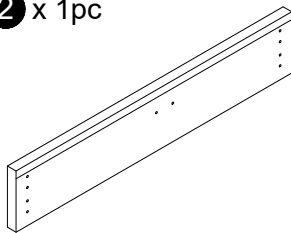

3 x 1pc

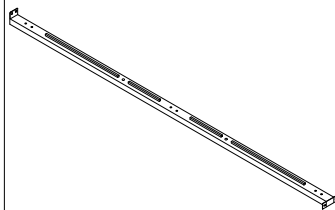

5 x 2pcs (25x25mm)



6 x 2pcs

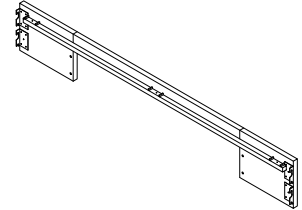

7 x 2pcs (40x225mm)

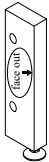

8 x 2pcs (40x225mm)



10 x 2pcs

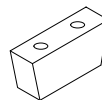

14 x 2pcs

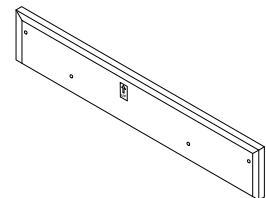

B x 2pcs

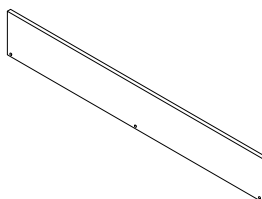

D x 2pcs

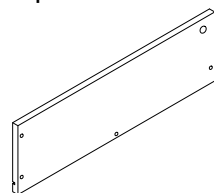













E x 10pcs

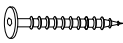

Please ensure to thoroughly inspect the small inner cardboard box containing the hardware, which are tied with a red string, before disposing of the box.

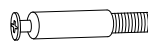
HARDWARE LIST

 H1 M5 x 1pc	 H2 M8x30mm x 16pcs	 H3 M8x50mm x 25pcs	 H4 M8x40mm x 16pcs
 H5 M8 x 8pcs	 H6 M8x22mm x 27pcs	 H8 x 6pcs	 H9 x 3pcs
 H10 M6x45mm x 28pcs	 H11 M4 x 1pc	 H12 x 4pcs	 H13 x 4pcs

1

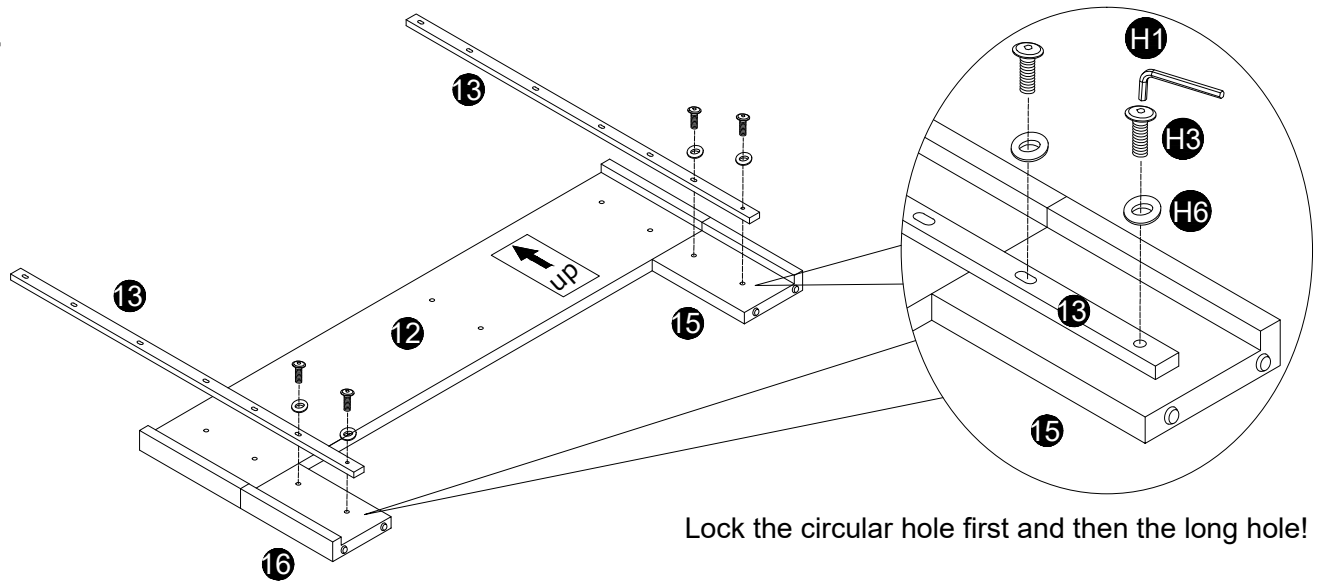

Lock the circular hole first and then the long hole!

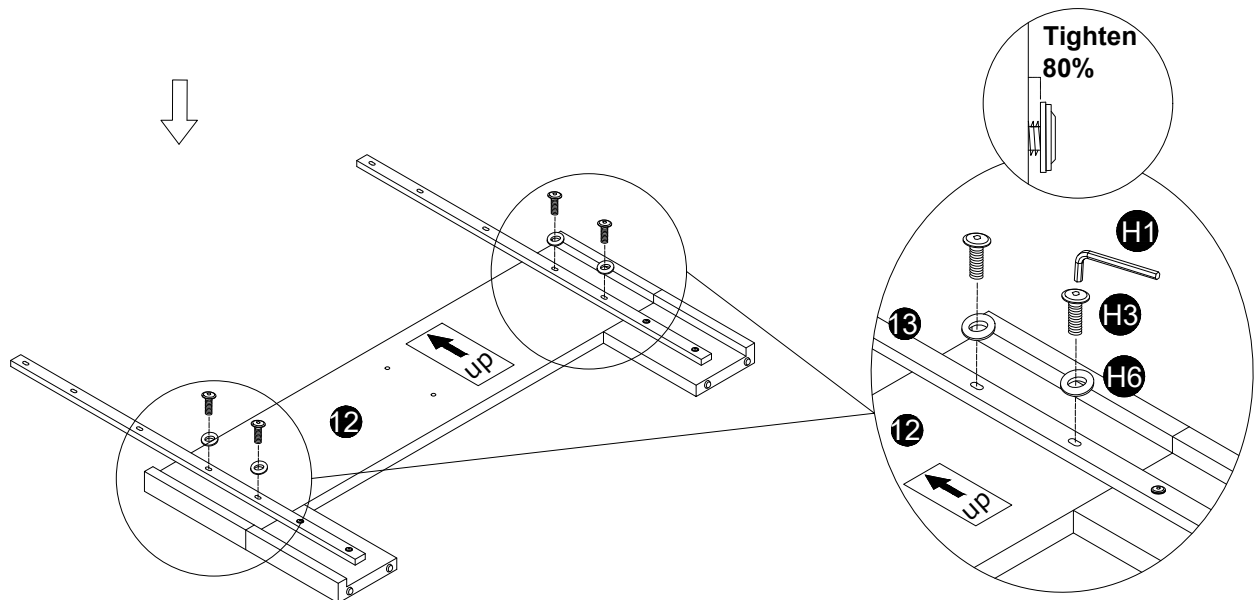

4

2

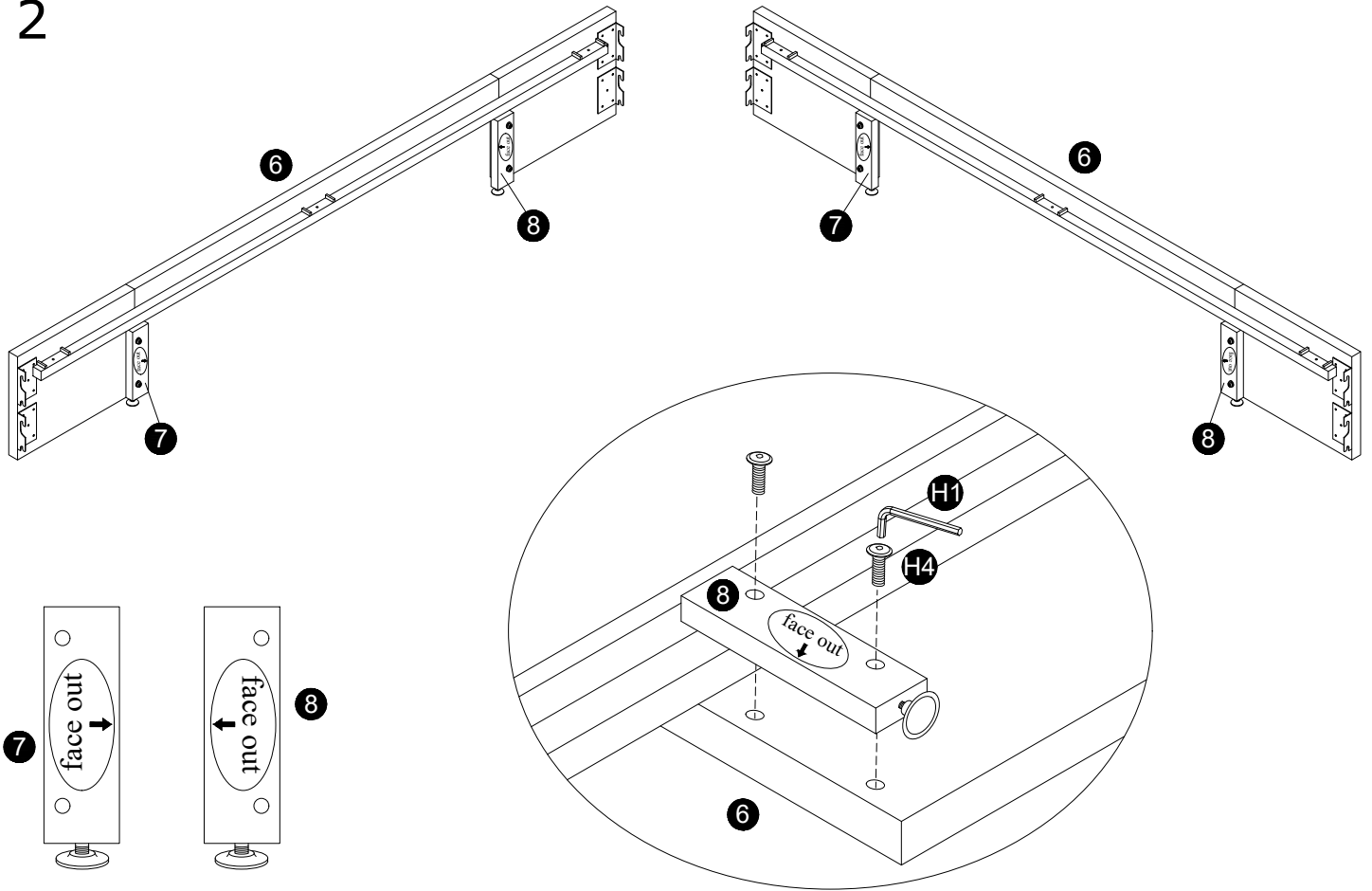

3

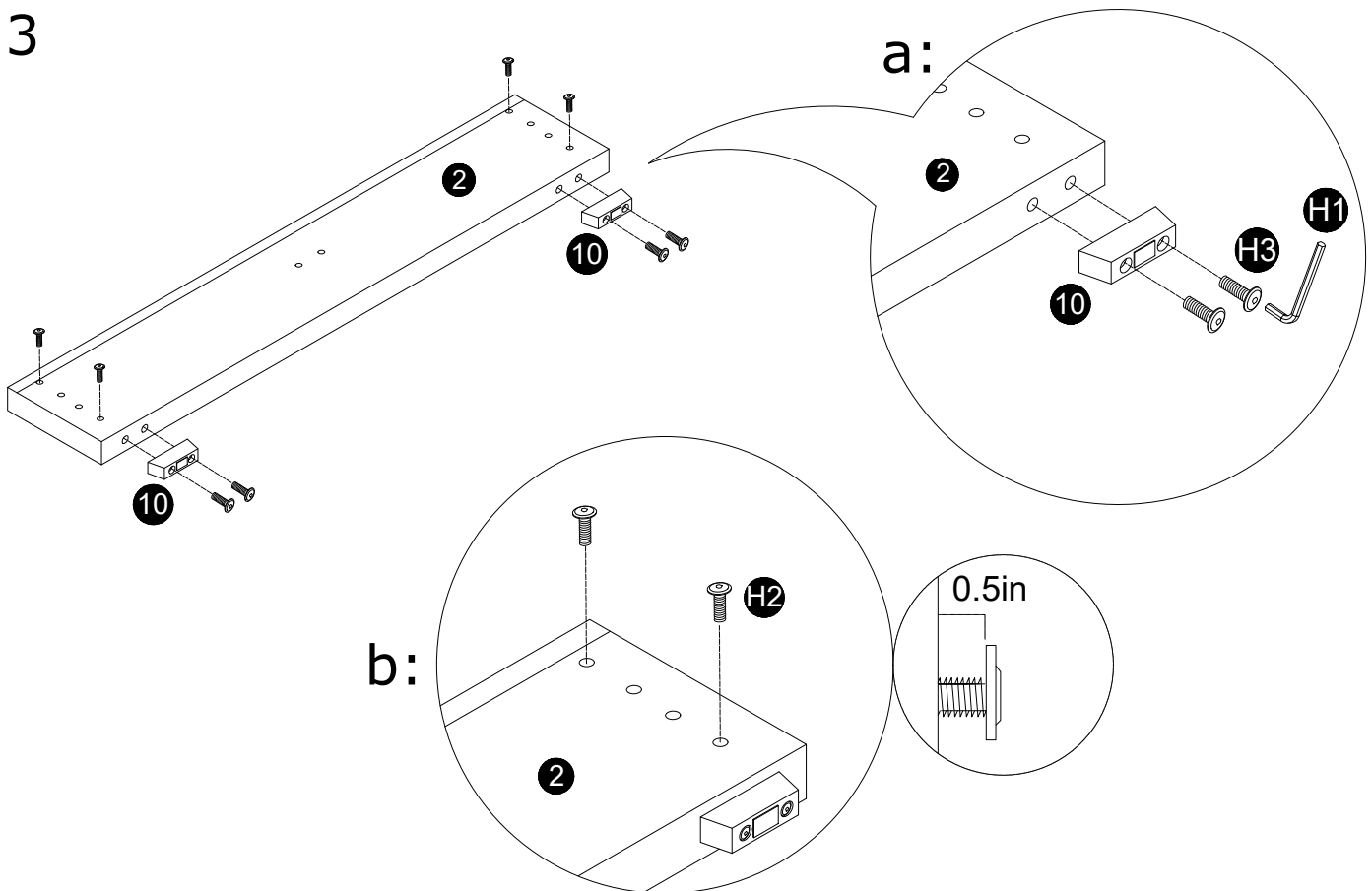

4

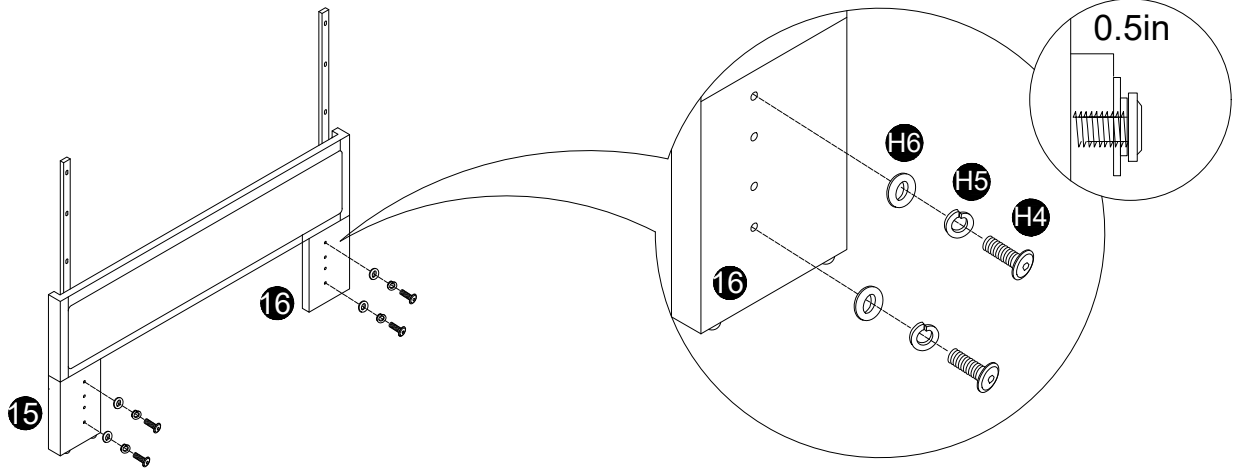

5

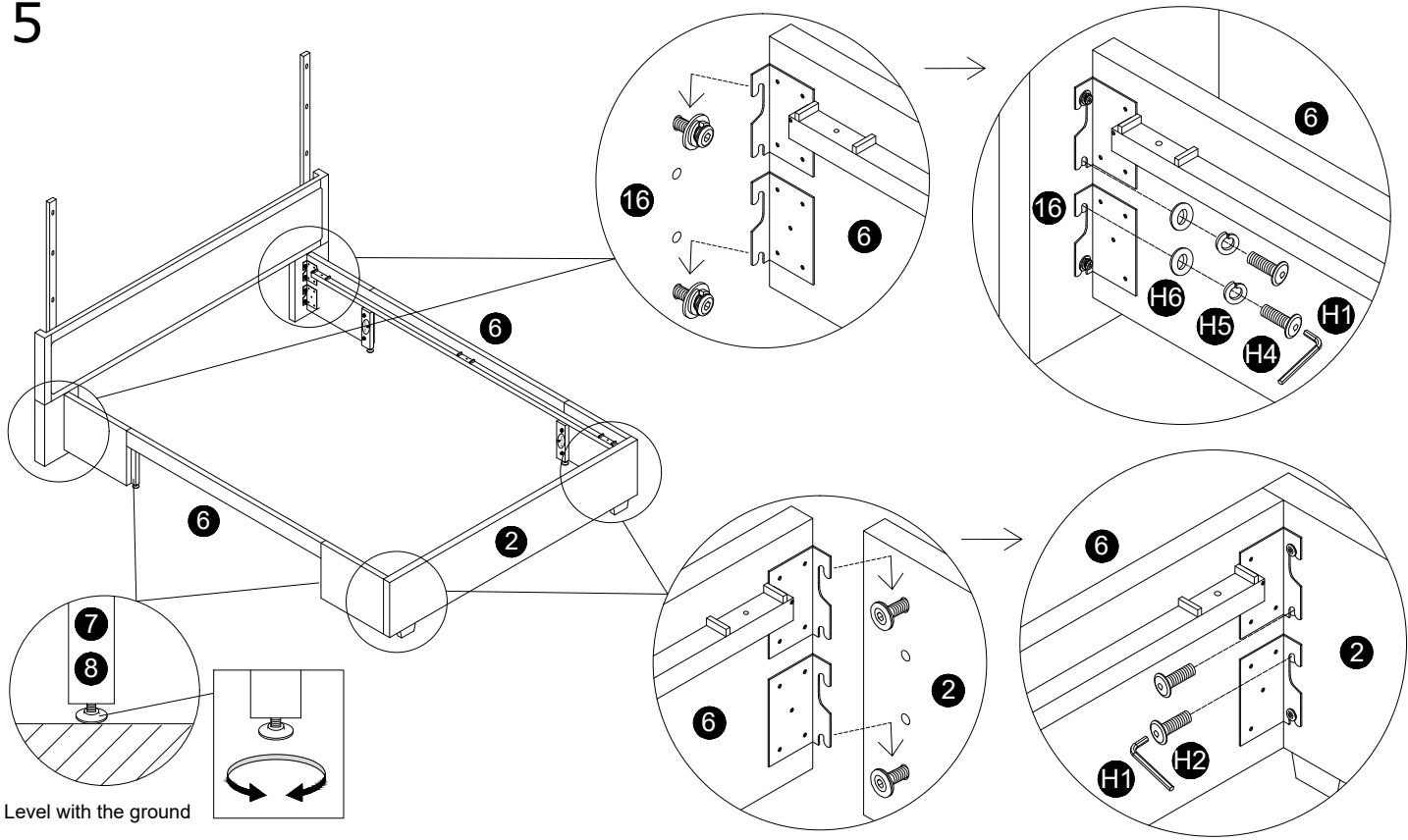

6

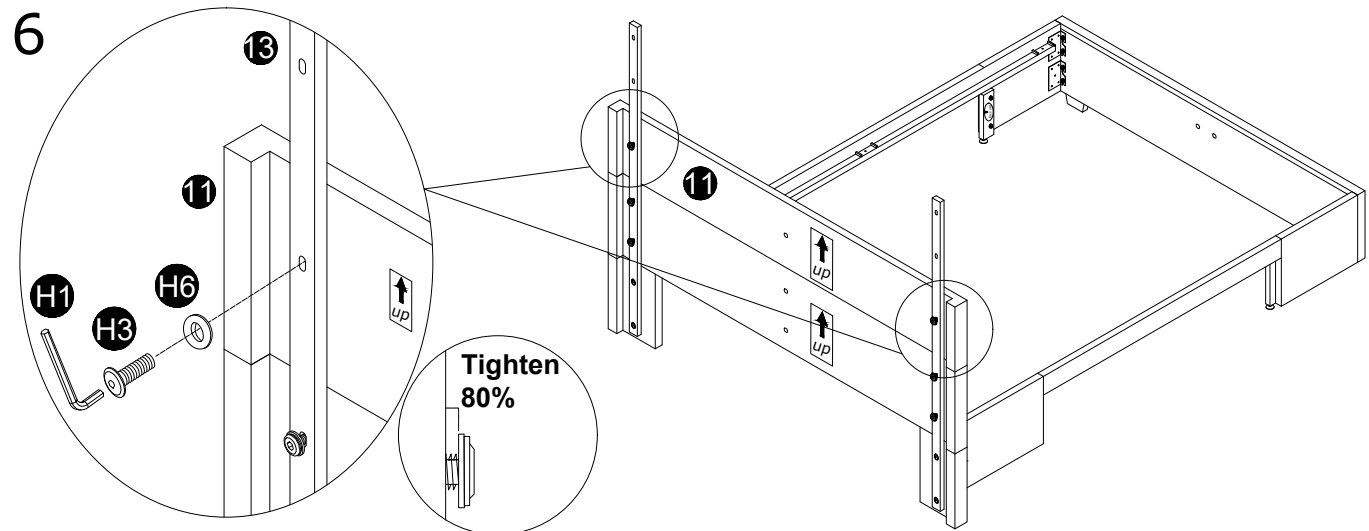

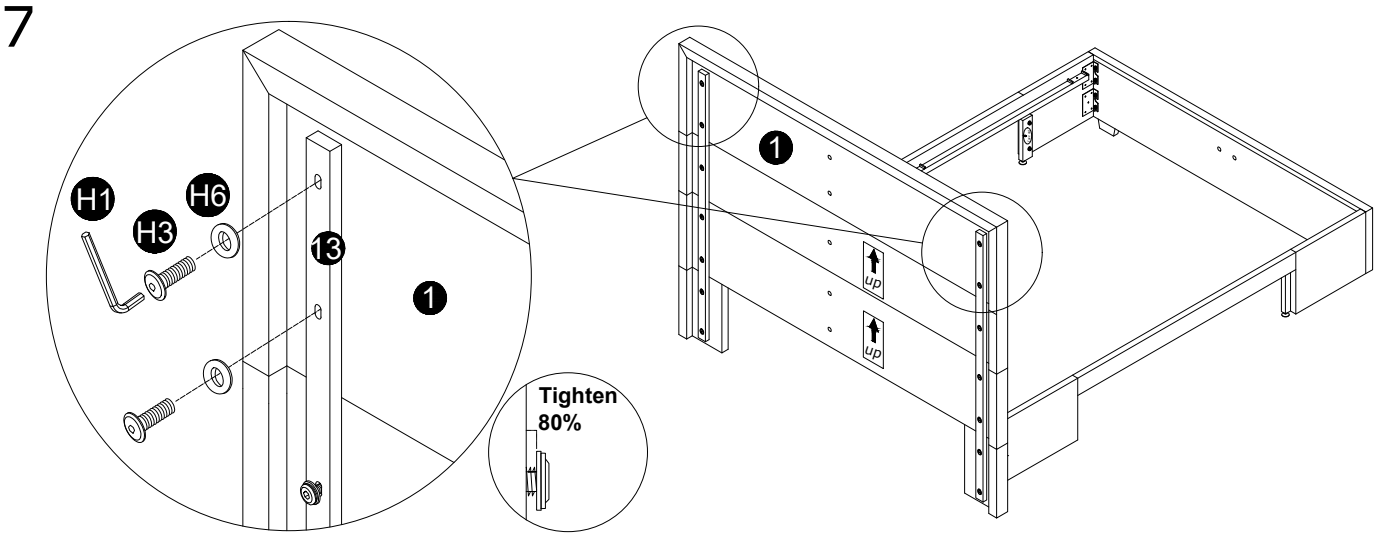

8 As shown in the diagram, align the screws with the corresponding holes and pre-fix them. Then, tighten each screw separately.

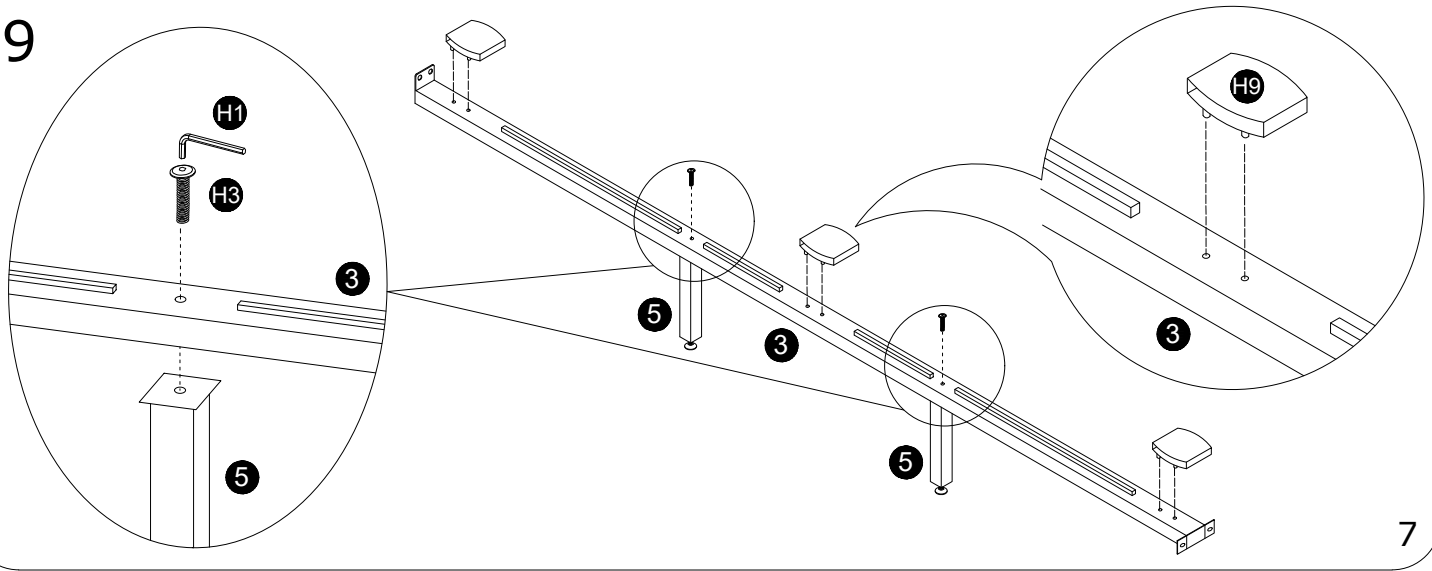
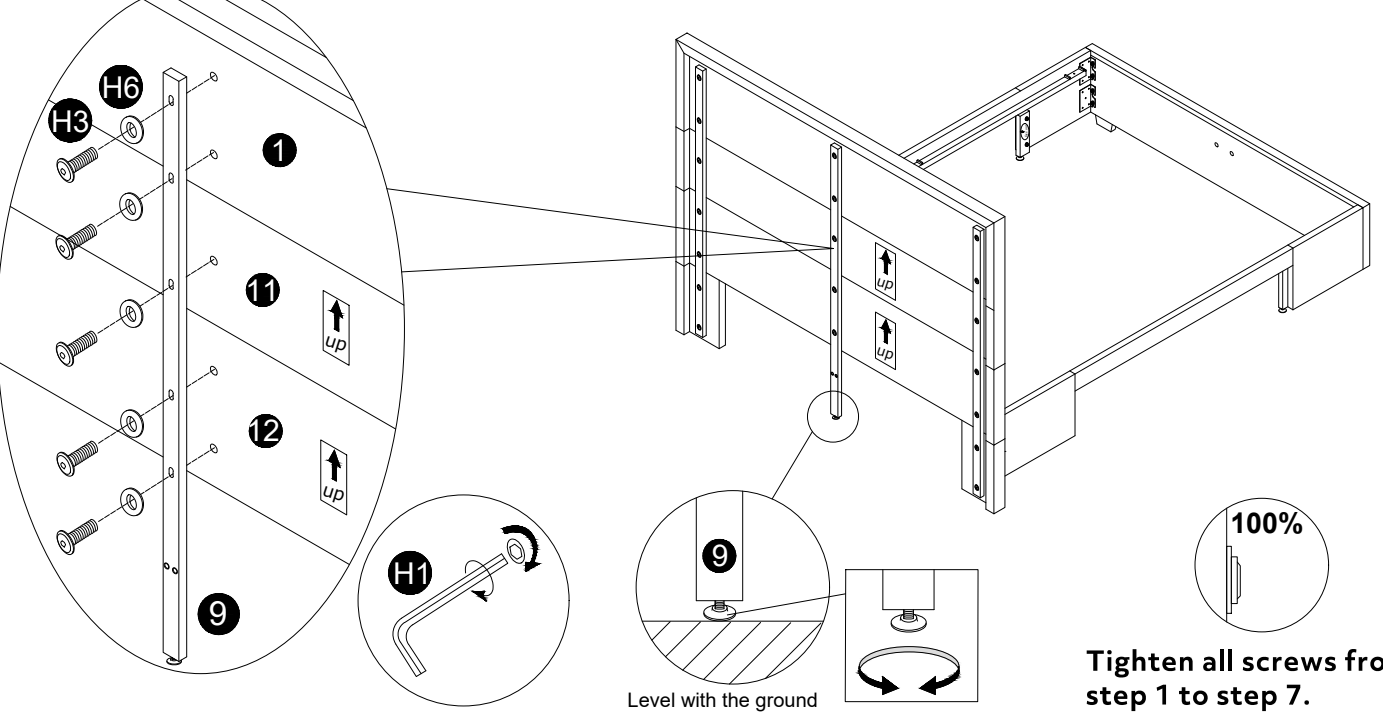

10

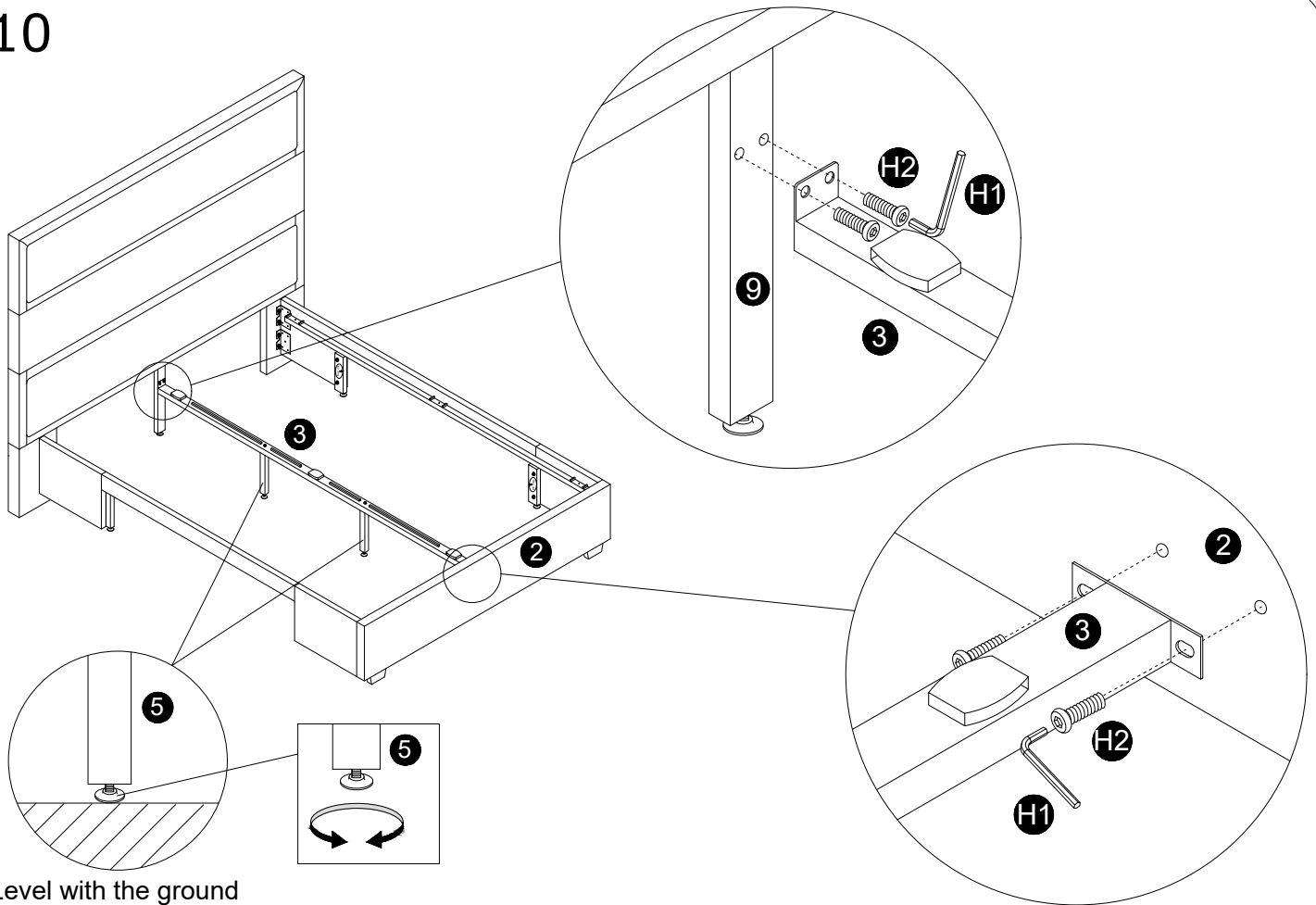

11

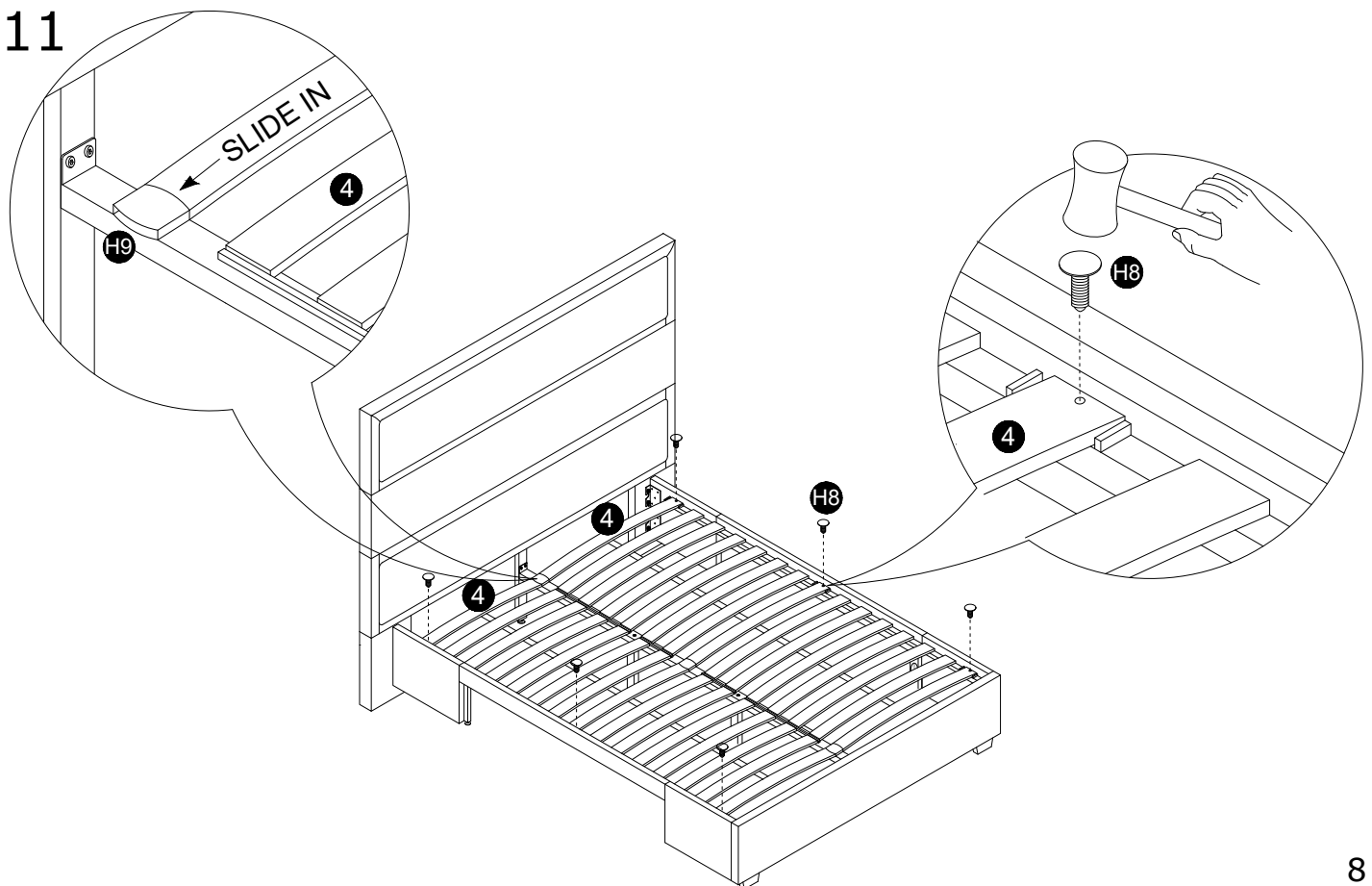

12

x2

Grooves to align

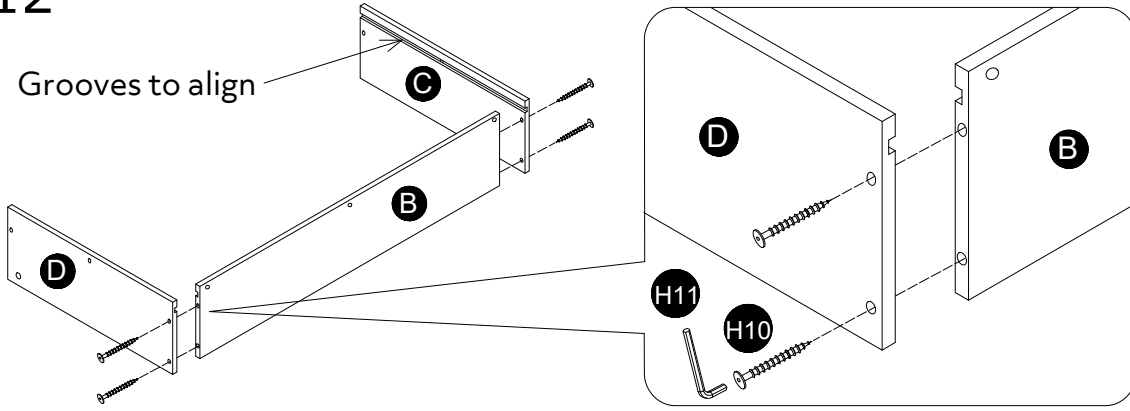

13

x2

a:

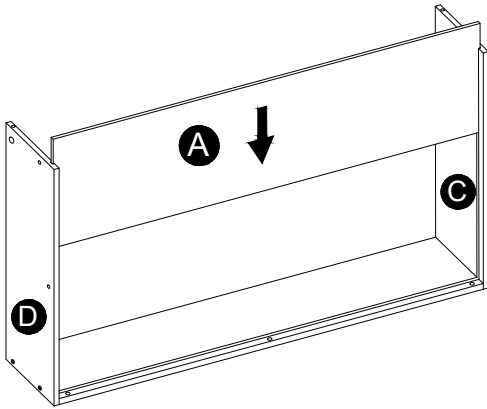

b:

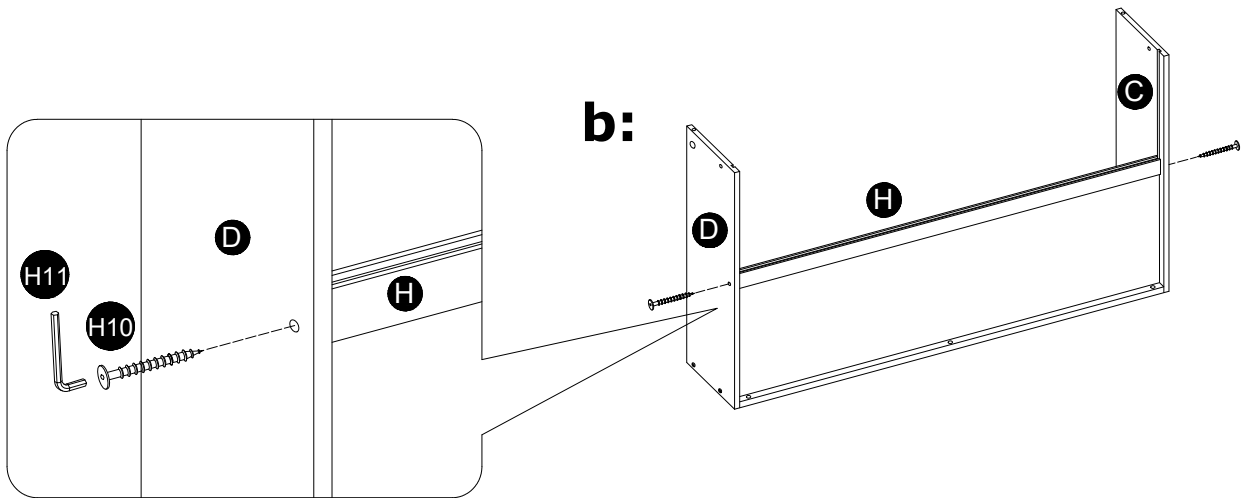

c:

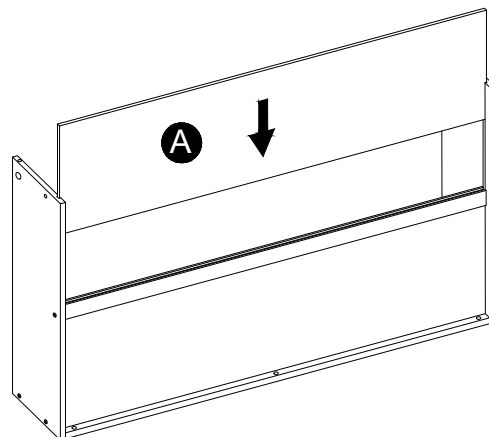

14

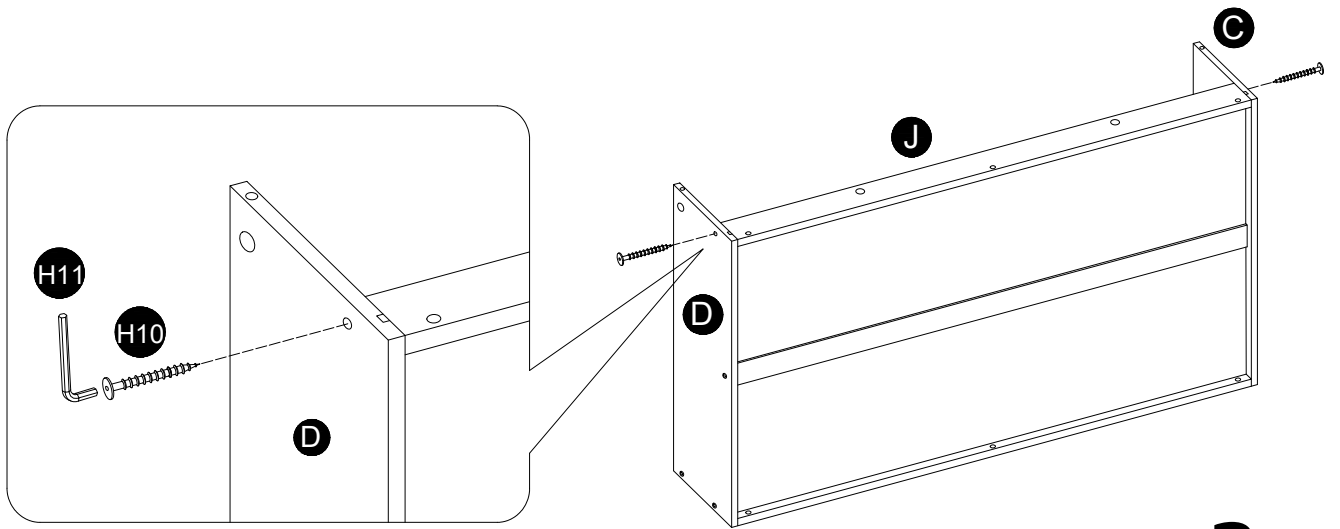

x2

15

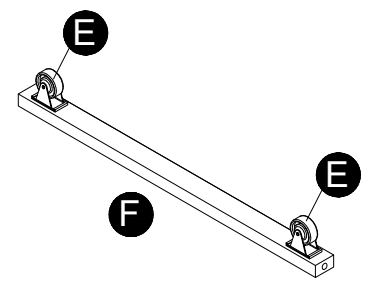
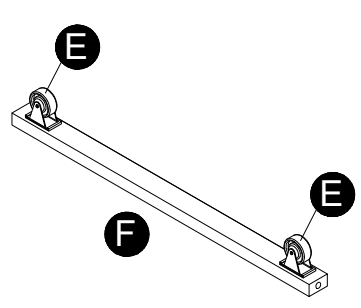

x2

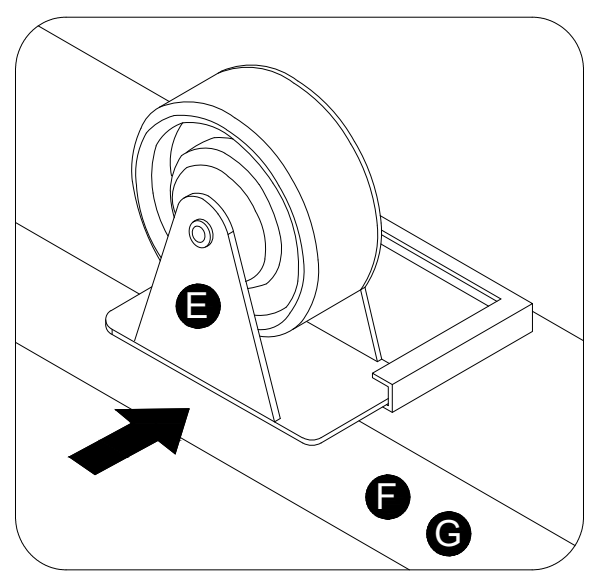
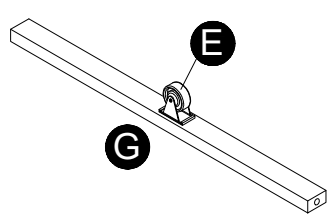

16 **x2**

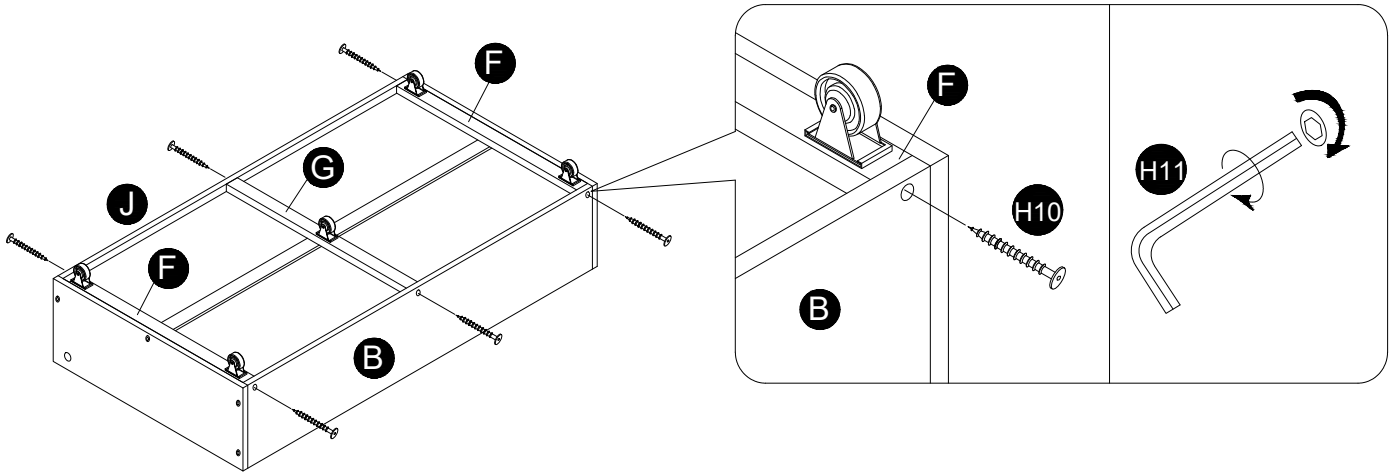

17 **x2**

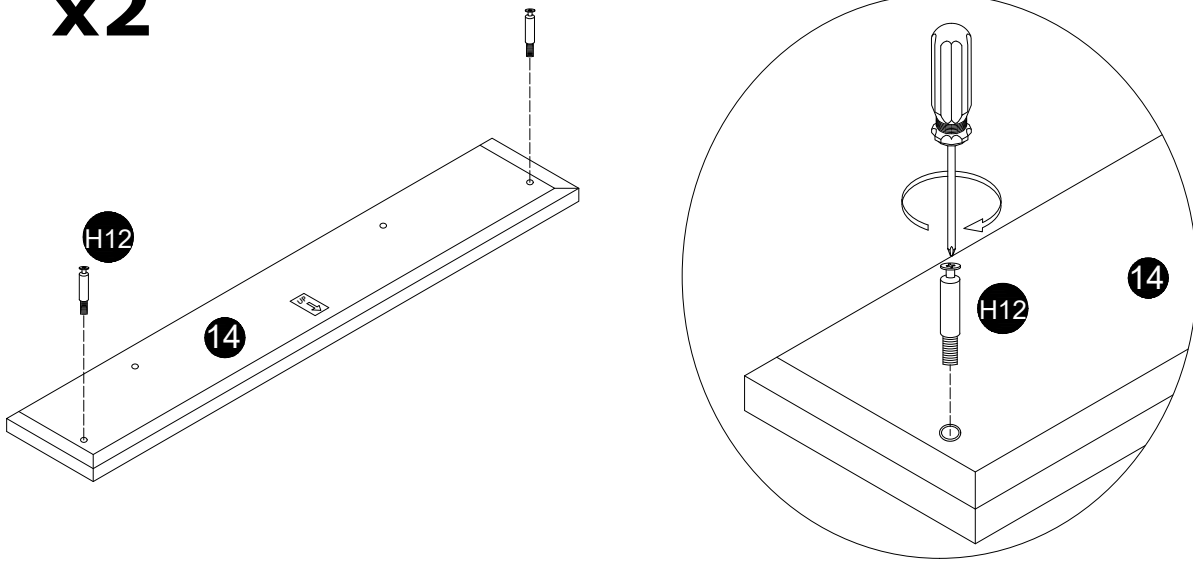

18 **x2**

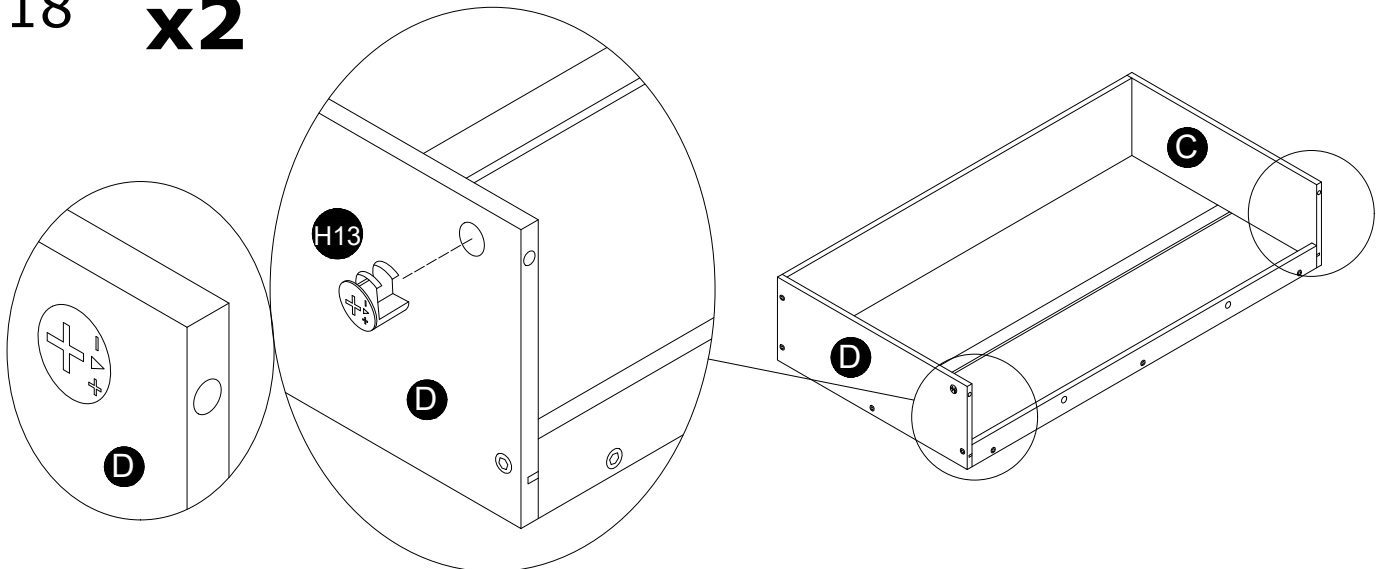

19 **x2**

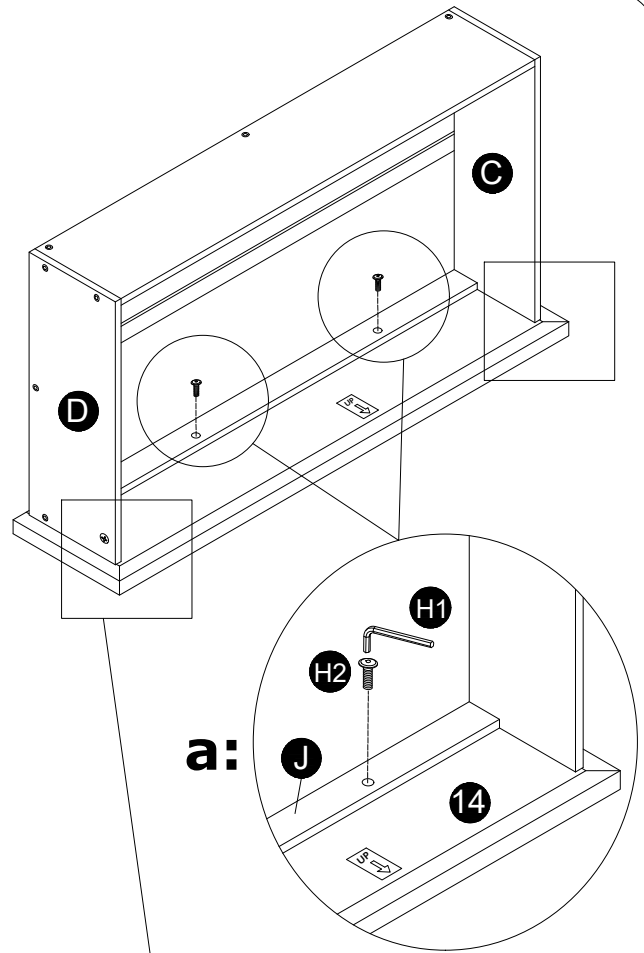
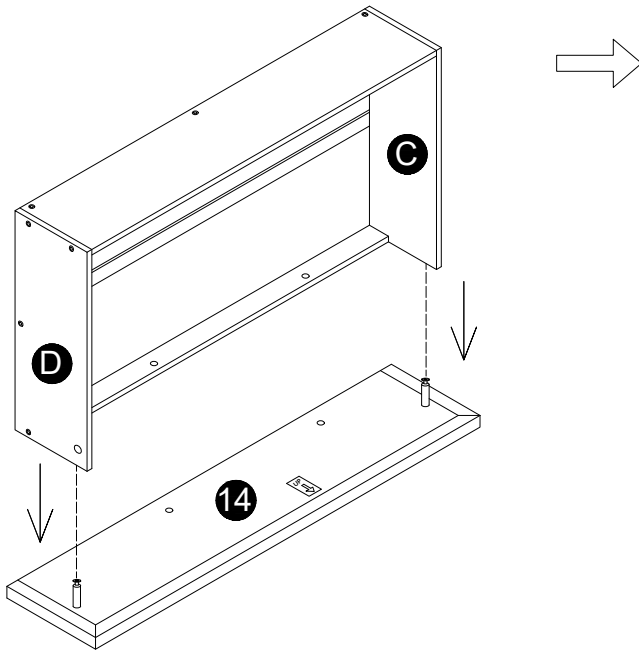

PUSH THE TWO PANELS TOGETHER ALLOWING THE DOWEL TO ALIGN WITH THE HOLE

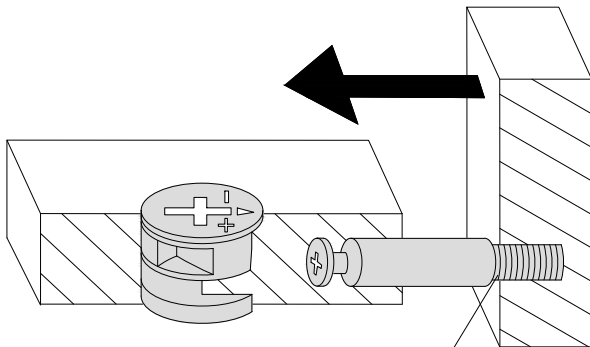

If H12 cannot lock into H13, you can adjust H12 outward by 2mm.

TURN THE CAM IN A CLOCKWISE DIRECTION

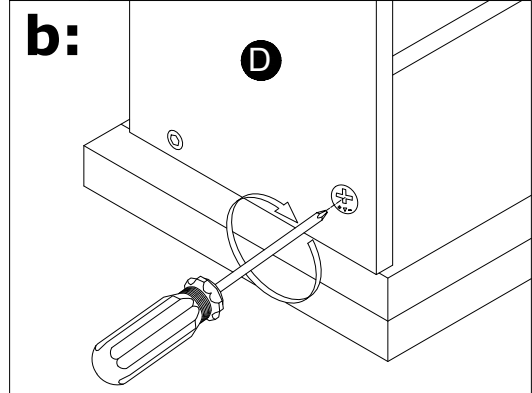
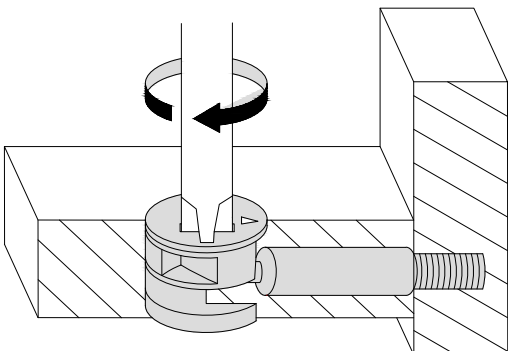

DON'T STOP UNTIL THE 2 O'CLOCK LOCK
TURN THE CAM IN A CLOCKWISE DIRECTION UNTIL THE ARROW POINTS IN THE POSITIONS SHOWN IN THE DIAGRAMS BELOW

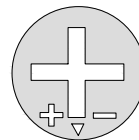

OPEN

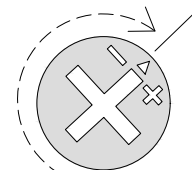

LOCKED

Job Complete !

In the interest of our environment please dispose of all packaging thoughtfully.