









# ASSEMBLY INSTRUCTION

## NAILHEAD SIDE CHAIR

<b>A</b> Chair Back  1 pc	<b>B</b> Seat Cushion  1 pc	<b>C</b> Front Leg  2 pcs	<b>D</b> Lock Washer Ø1/4  10 pcs
<b>E</b> Flat Washer Ø1/4 x 19 mm  10 pcs	<b>F</b> Allen Bolt Ø1/4**75mm  4 pcs	<b>G</b> Allen Bolt Ø1/4**38mm  2 pcs	<b>H</b> Allen Bolt Ø1/4**50mm  4 pcs
<b>I</b> Allen Key 4mm  1 pc			

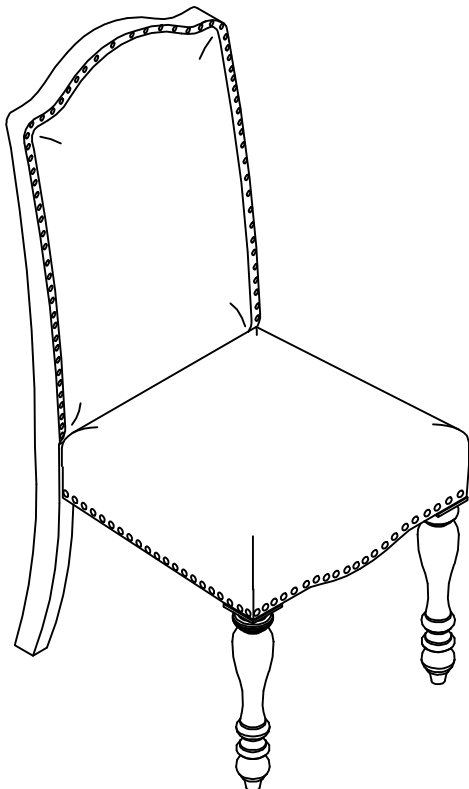

This page lists all the contents included in the box. Please take the time to identify the hardware as well as the individual components to this product. As you unpack and prepare for assembly, place the contents on a carpeted or padded area to protect them from damage.

**\*\*\* Do not tighten screws & bolts until the entire unit is completely assembled.**

**1** Attach Seat Cushion(B) to Chair Back(A) using Allen Bolt(G), Lock washer(D), Flat Washer(E) and Allen Key(I).

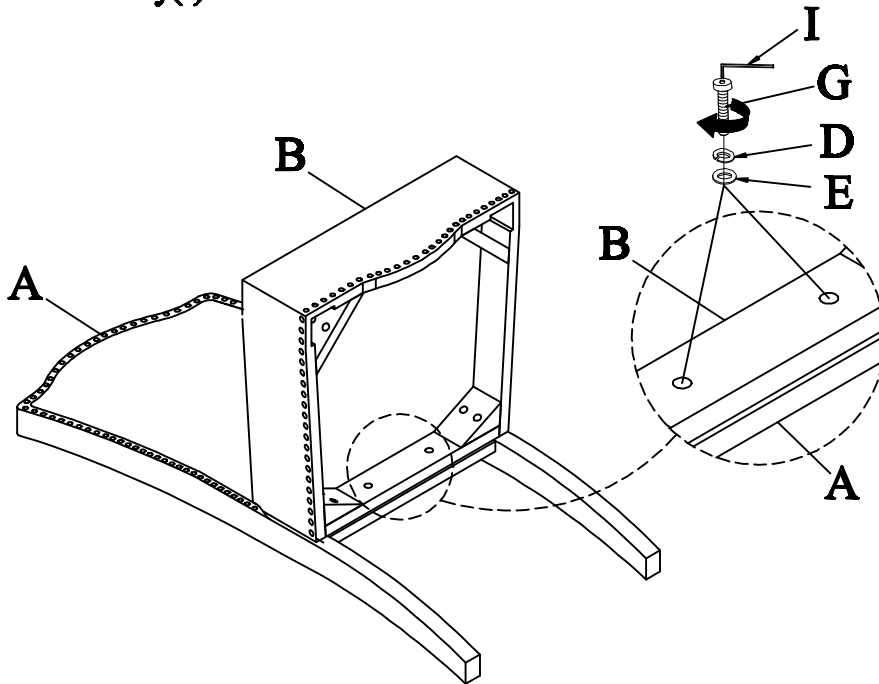

Take the Allen Wrench, and turn the bolts until the legs are secure.

**DO NOT TIGHTEN COMPLETELY.**

Stop when you feel you are adding force to tighten the bolt.

**2** Using Allen Bolt(F), Lock washer(D), Flat Washer(E) and Allen Key(I) into the holes at the corner.

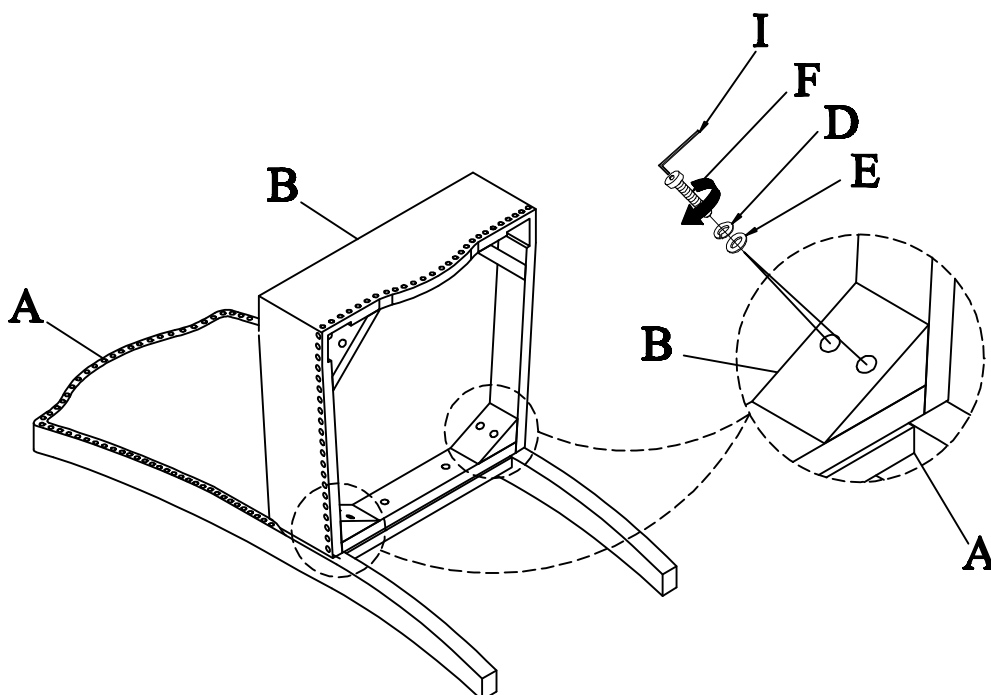

**3**

Attach Front Leg(C) to Seat Cushion(B) using Allen Bolt(H), Lock washer(D), Flat Washer(E) and Allen Key(I).

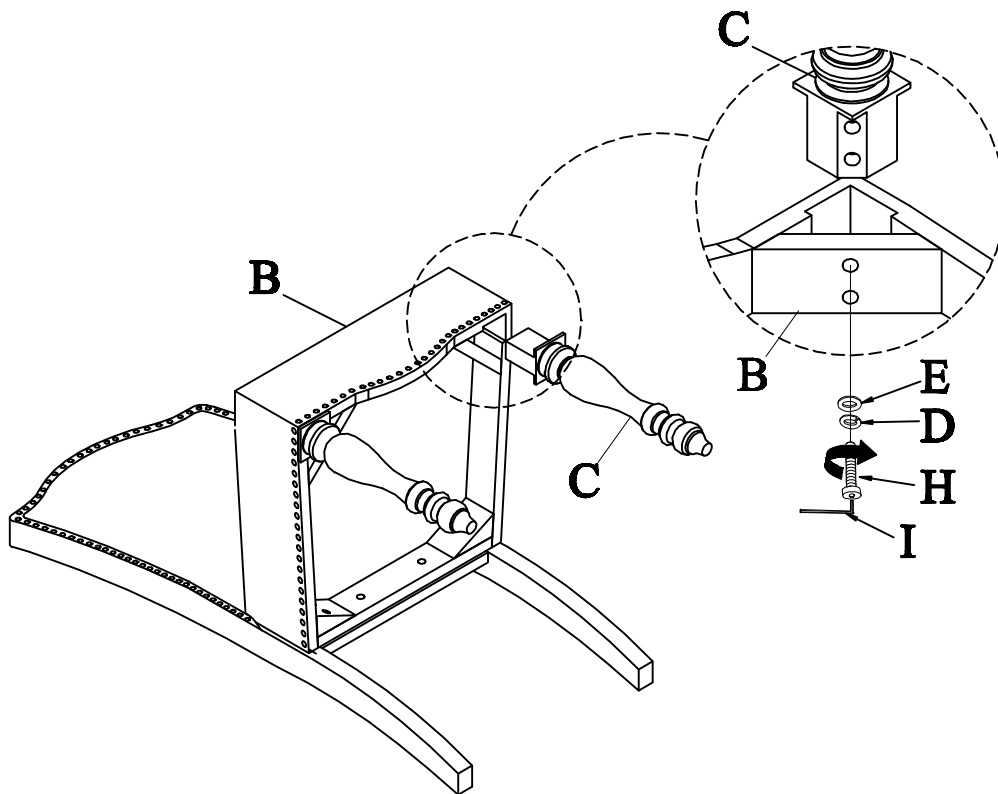

Stand chair up on an even surface and check that it is balanced.

If there is a slight wobble, apply downward pressure in the corner where a leg is uneven. Keeping pressure in that corner, tighten all bolts.

If balanced, apply downward pressure evenly in the center and tighten all bolts.

Do not over-tighten beyond hole depth.

**Helpful Tip:**

-Instead of applying downward pressure while reaching under to tighten bolts, have someone sit in the chair while you tighten the bolts.

---

#### Cleaning & Care

Treat surface with care. Surface is resistant to scratches but is not scratch resistant. Clean surfaces with a dry or damp soft cloth. Do not use abrasive cleaners. Hardware may loosen over time. Periodically check that all connections are tight.