

ASSEMBLY INSTRUCTIONS

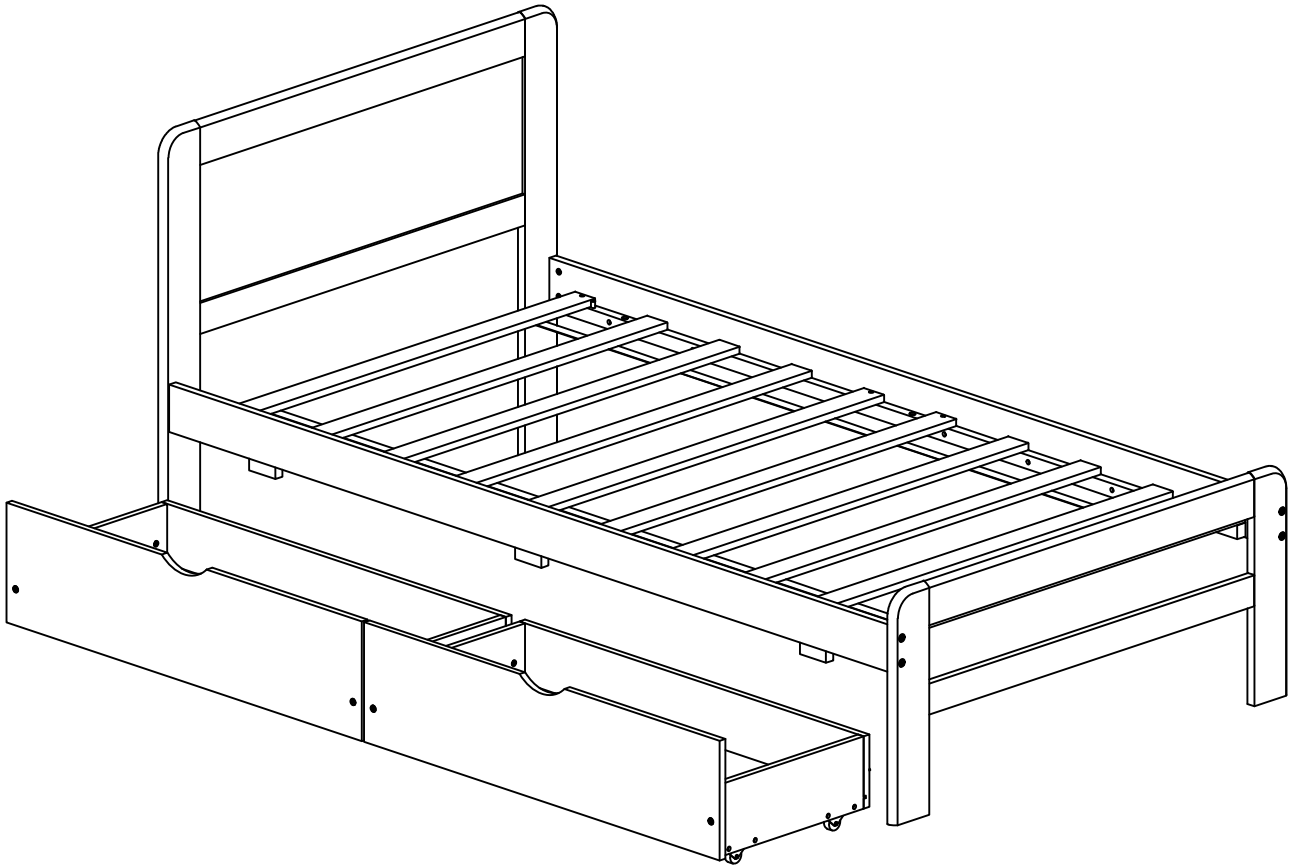

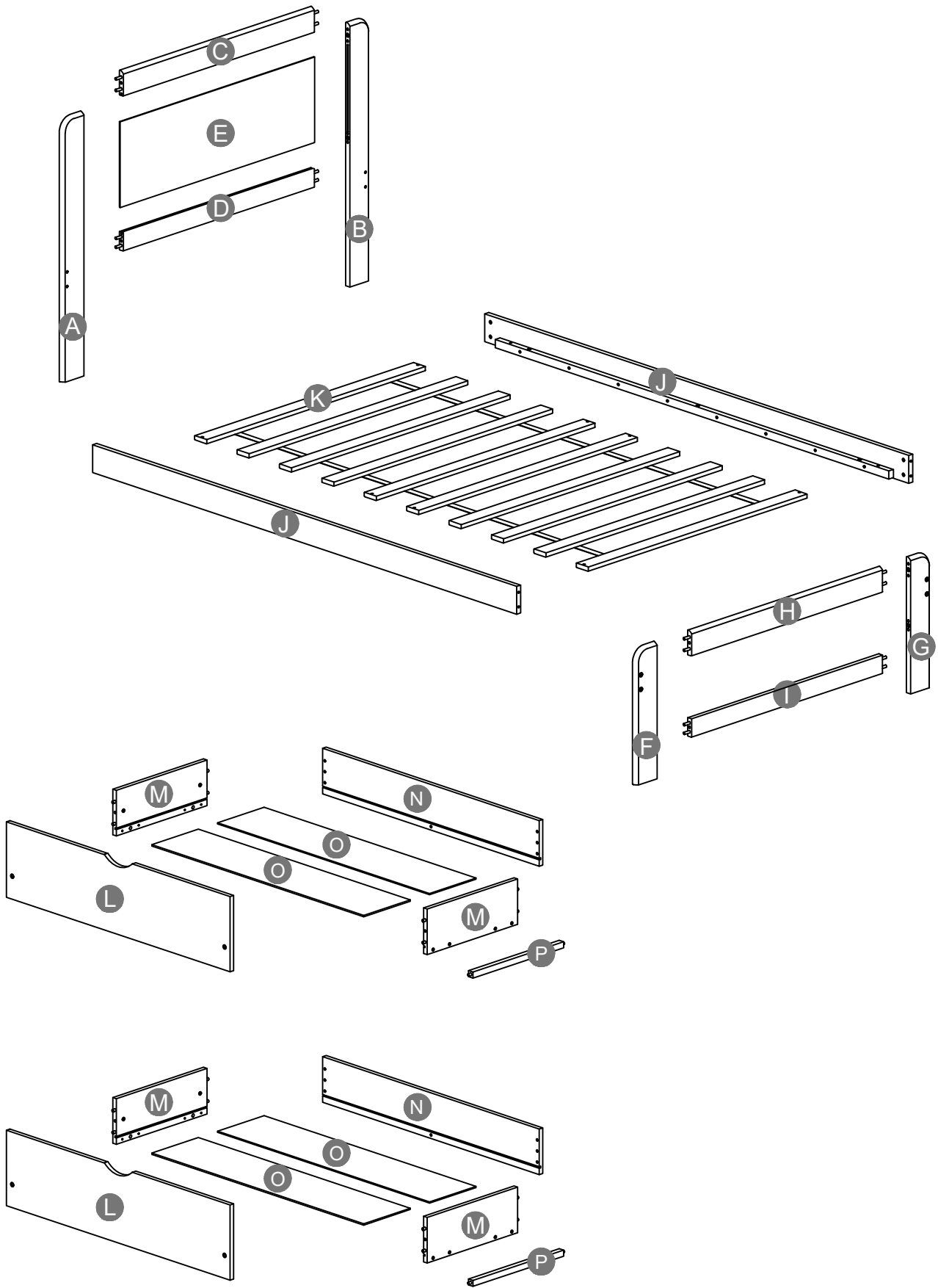







YX7101

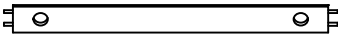
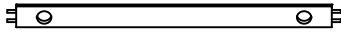

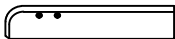
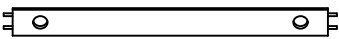
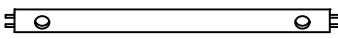
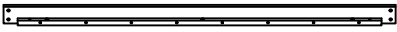
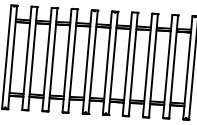
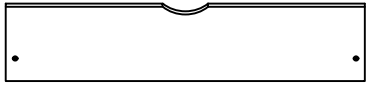
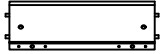

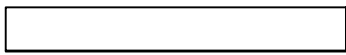



Detail View

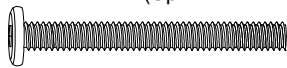

Part List

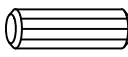
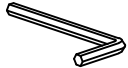
| | | |
|---|---|---|
| <p>A</p>  <p>Headboard leg (Left)-1pc</p> | <p>B</p>  <p>Headboard leg (Right)-1pc</p> | <p>C</p>  <p>Horizontal upper bar HB-1pc</p> |
| <p>D</p>  <p>Horizontal bottom bar HB-1pc</p> | <p>E</p>  <p>Headboard panel-1pc</p> | <p>F</p>  <p>Footboard leg (Left)-1pc</p> |
| <p>G</p>  <p>Footboard leg (Right)-1pc</p> | <p>H</p>  <p>Horizontal upper bar FB-1pc</p> | <p>I</p>  <p>Horizontal bottom bar FB-1pc</p> |
| <p>J</p>  <p>Side rail-2pcs</p> | <p>K</p>  <p>Slat-10pcs</p> | <p>L</p>  <p>Front panel of drawer - 2pcs</p> |
| <p>M</p>  <p>Side panel of drawer - 4pcs</p> | <p>N</p>  <p>Back panel of drawer - 2pcs</p> | <p>O</p>  <p>Bottom panel of drawer-4pcs</p> |
| <p>P</p>  <p>Crossprece-2pcs</p> | | |

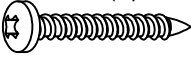
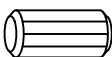
Hardware List

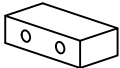
| | | |
|--|--|---|
| 1  (Spare Hardware-1pc) 1/4"*9.8*5mm | 2  (Spare Hardware-1pc) 1/4"*89mm | 3  (Spare Hardware-1pc) Ø8-28*14*7mm |
| Hexagon Nut (9pcs) All thread bolt(9pcs) Curved washer(9pcs) | | |
| 4  (Spare Hardware-2pcs) (Ø12)1/4"*55mm | 5  (Spare Hardware-1pc) 1/4"*15mm | 6  (Spare Hardware-1pc) Ø4*32mm |
| Hex-Head bolts (21pcs) Horizontal-Hole bolts(9pcs) Wood screws (9 pcs) | | |
| 7  Ø8*25mm | 8  (1/4")4*60mm | 9  88*22*2mm |
| Wood dowel (7pcs) Allen key (1pc) Wrench (1pc) | | |
| 10  (Spare Hardware-1pc) 1/4"*12mm | 11  (Spare Hardware-2pcs) Ø4*25mm | 12  (Spare Hardware-1pc) Ø10*20mm |
| Horizontal-Hole bolts(9pcs) Wood screws (18 pcs) Wood dowel (9pcs) | | |
| 13  100*53*19mm | 14  70*38*19mm | |
| Wheels (8pcs) Stopper (3pcs) | | |

ASSEMBLY TOOLS REQUIRED (NOT INCLUDED)

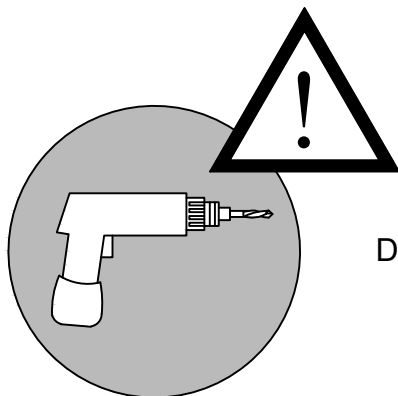
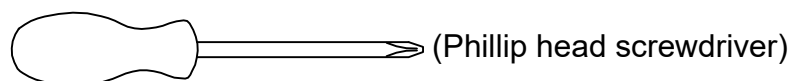

DO NOT USE POWER TOOLS TO ASSEMBLE THIS PRODUCT !

Remark: We recommend you assemble your bed in the flat ground.

STEP 1:

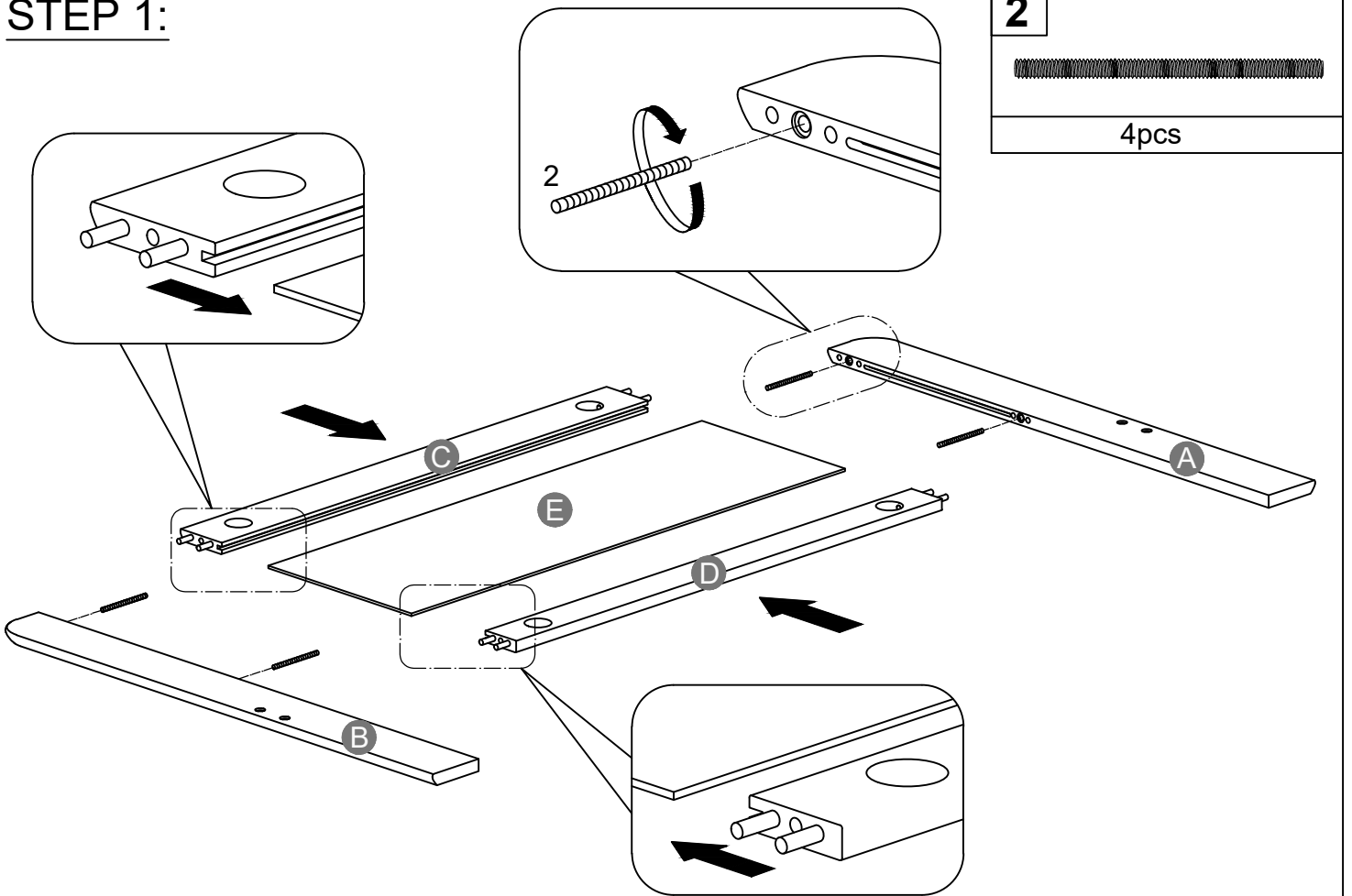

STEP 2:

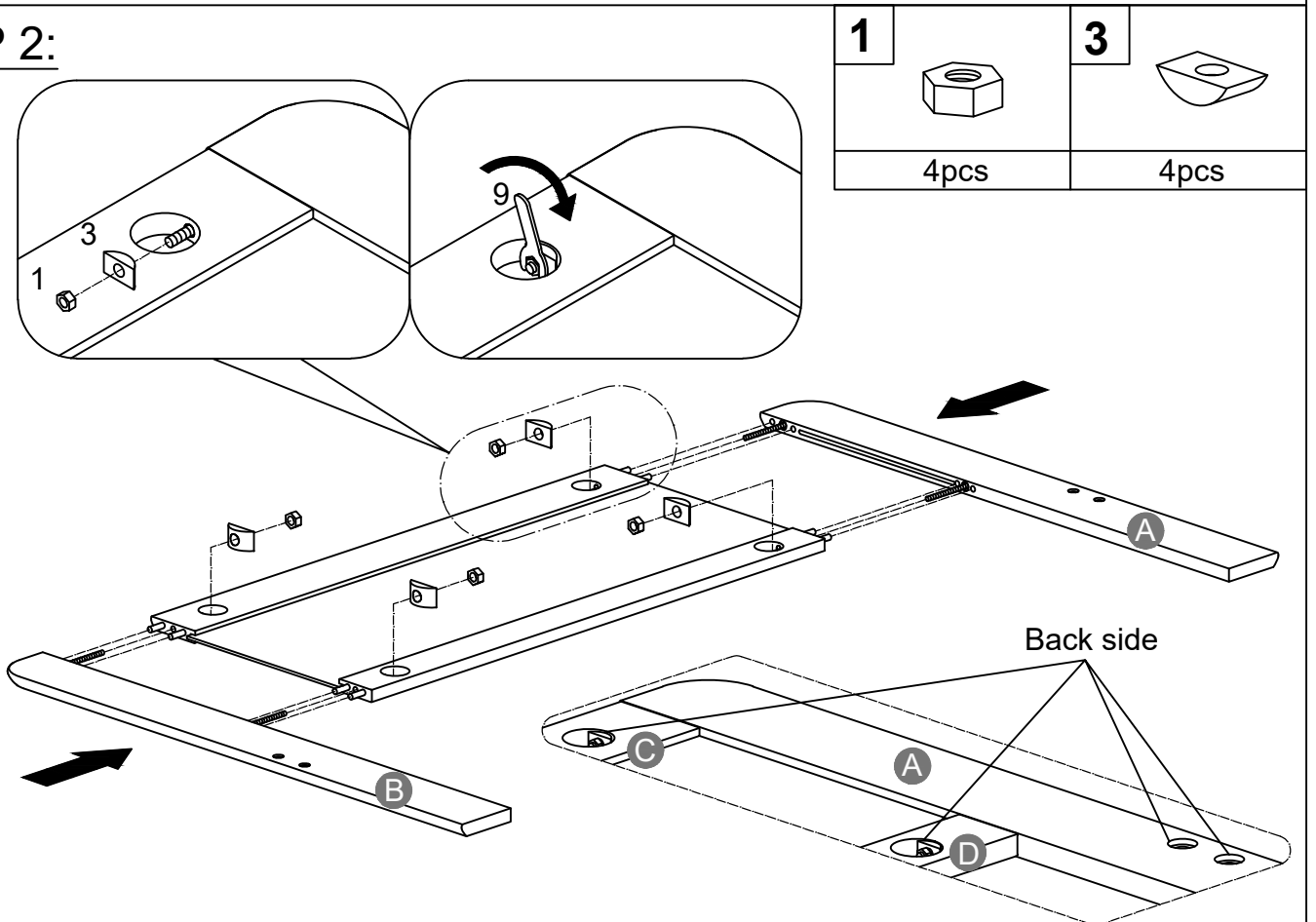

STEP 3:

2



4pcs

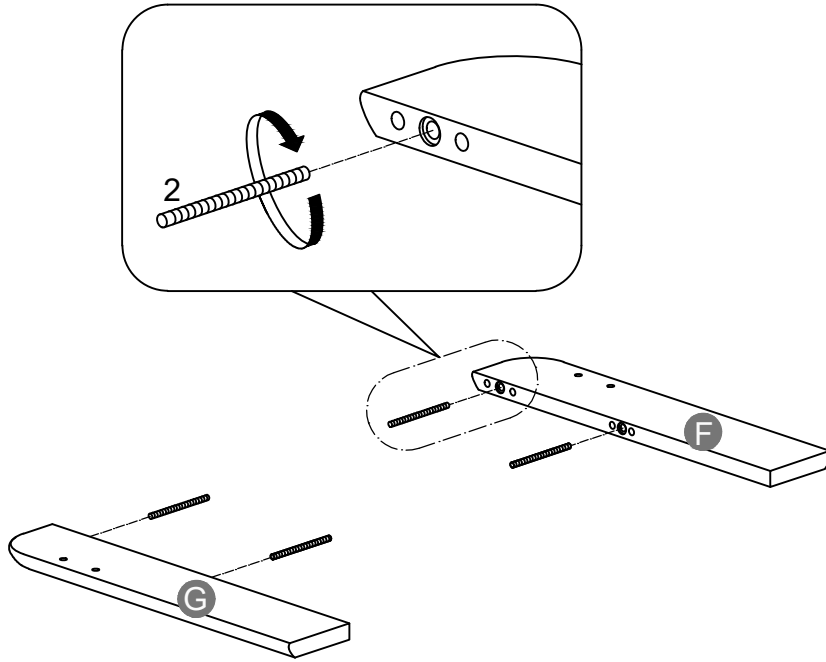

STEP 4:

1



4pcs

3



4pcs

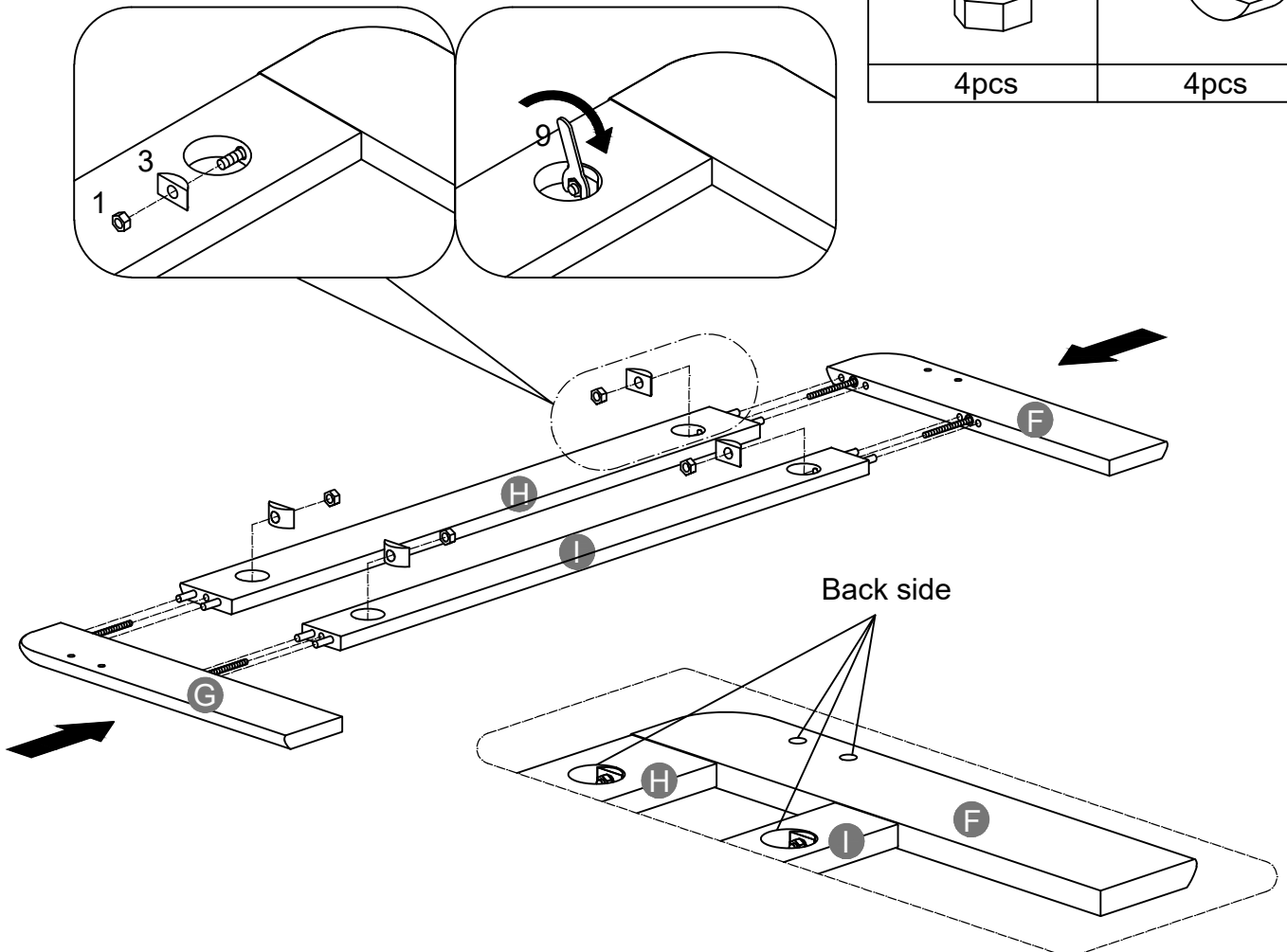

Make sure bars A,B,C,D are connected together on the same side (front-front, back-back)

STEP 5:

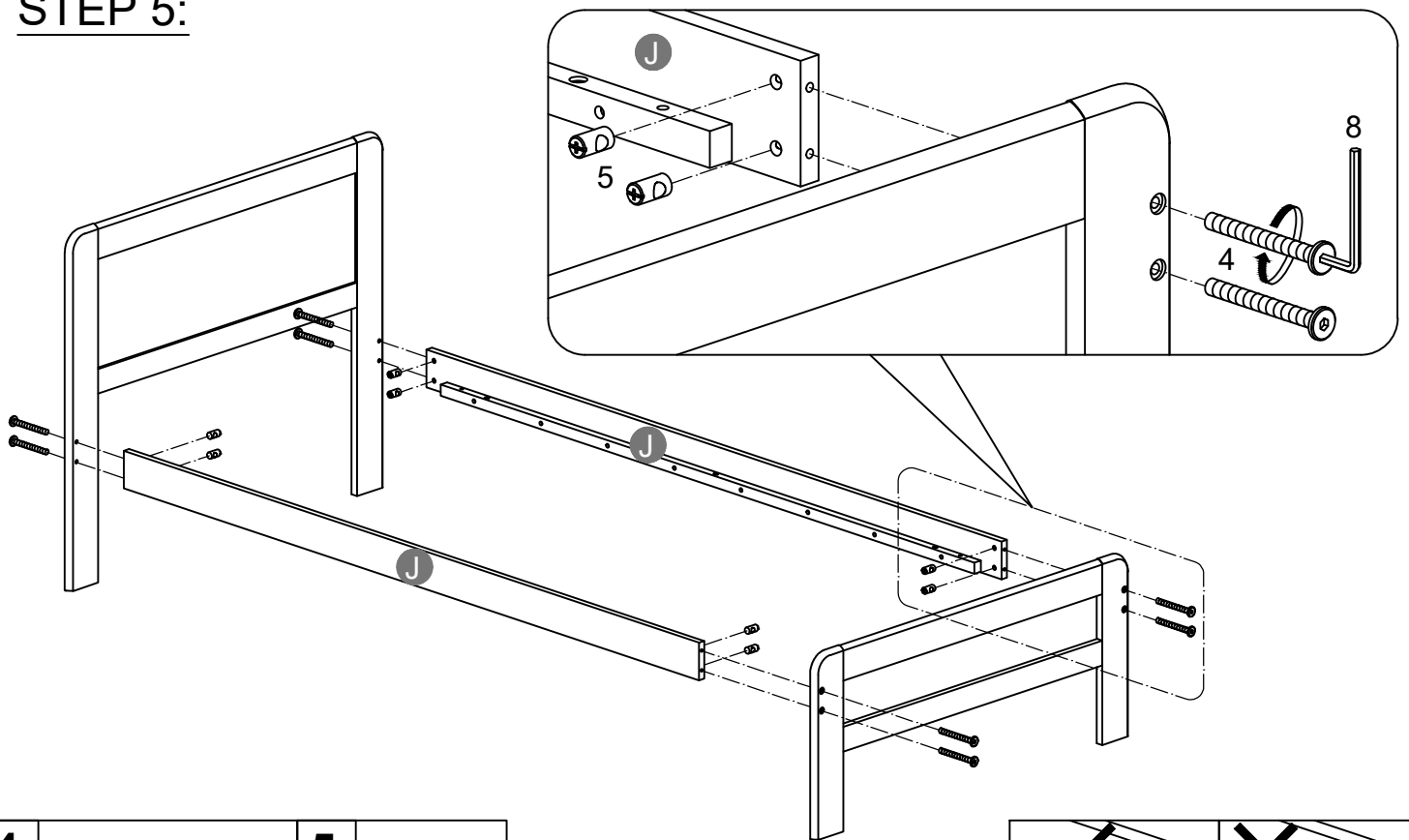

4



8pcs

5



8pcs

Note: Part 5 will face up with the "x" mark on it, otherwise it cannot be tightened

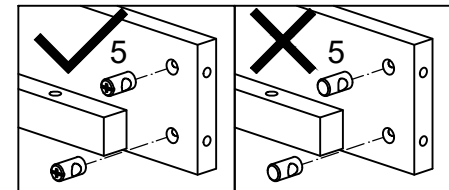

STEP 6:

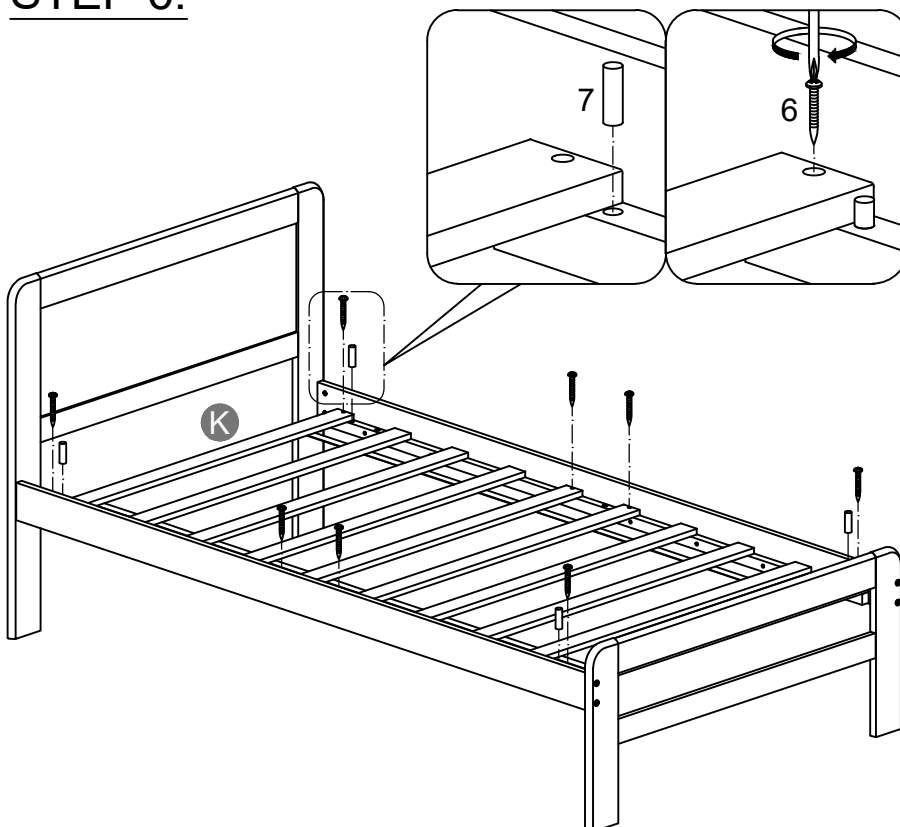

6



8 pcs

7

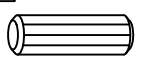

4pcs

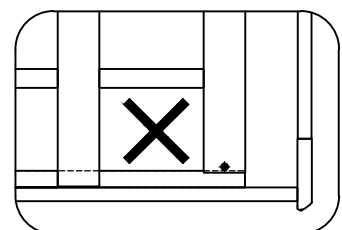
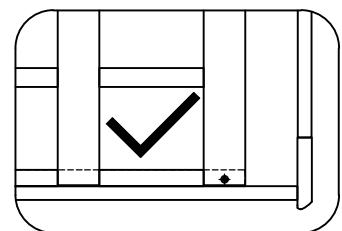

Note: Do not lock the screws of the bed slats to the outermost edge of the bed slats, you need to leave a certain space at the edges, otherwise it will cause the board to break. Do not lock the bed slats on the edge of the wood, please hold firmly before screwing, hold it in place with one hand, then lock the screw.

STEP 7:

4

10



4pcs

4pcs

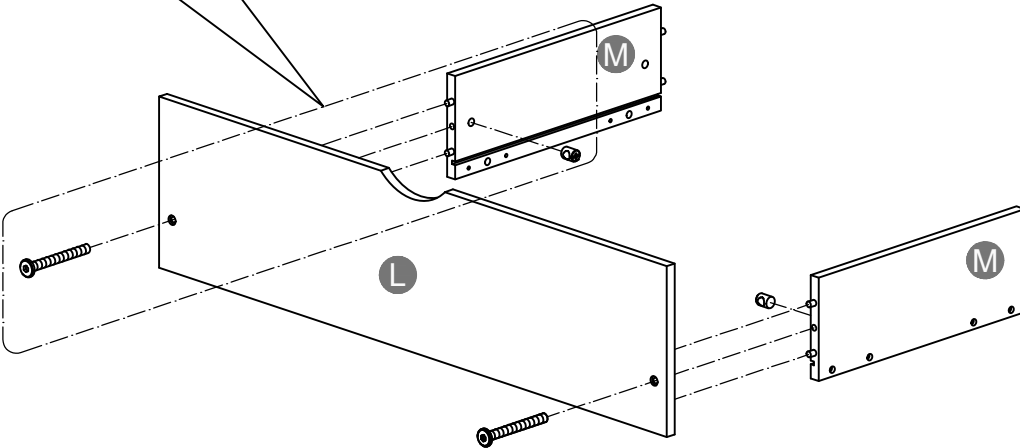
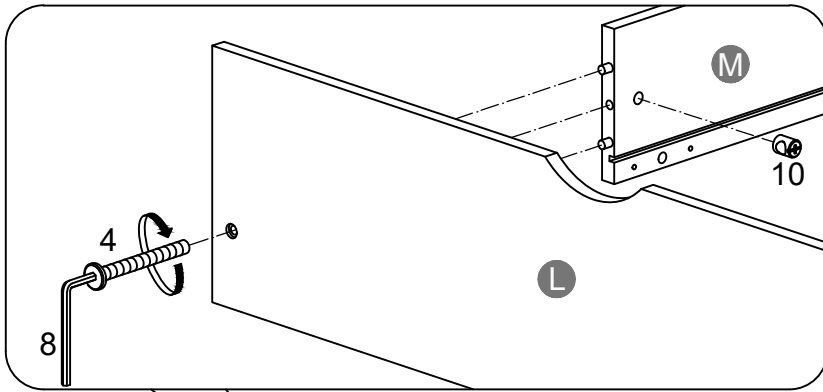

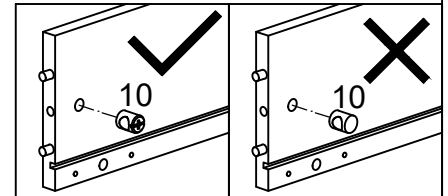

Note: Part 8 will face up with the "x" mark on it, otherwise it cannot be tightened

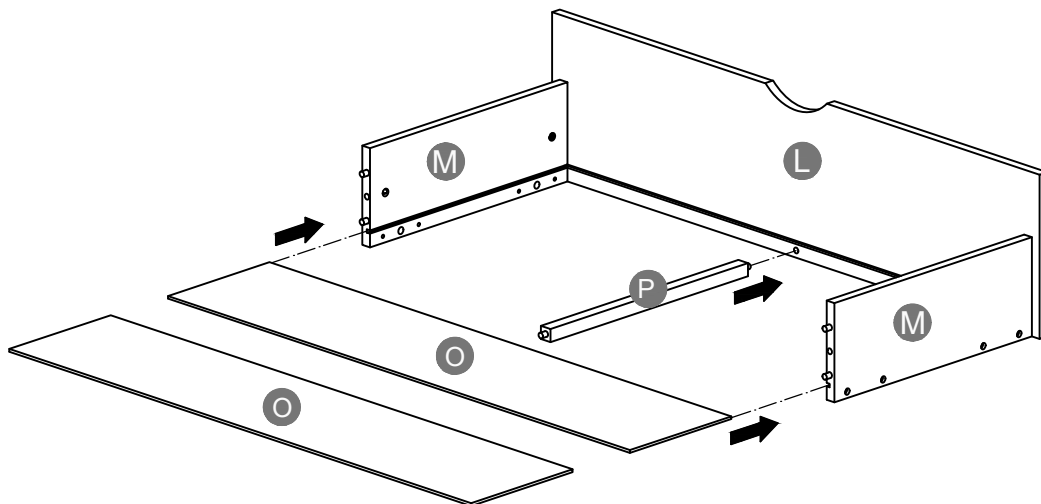
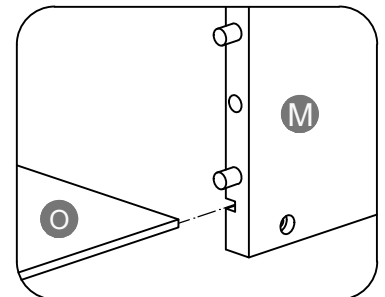
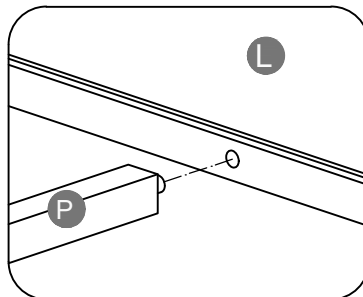

STEP 8:



STEP 9:

| | | | |
|----------|---|-----------|---|
| 4 |  | 10 |  |
| 4pcs | | 4pcs | |

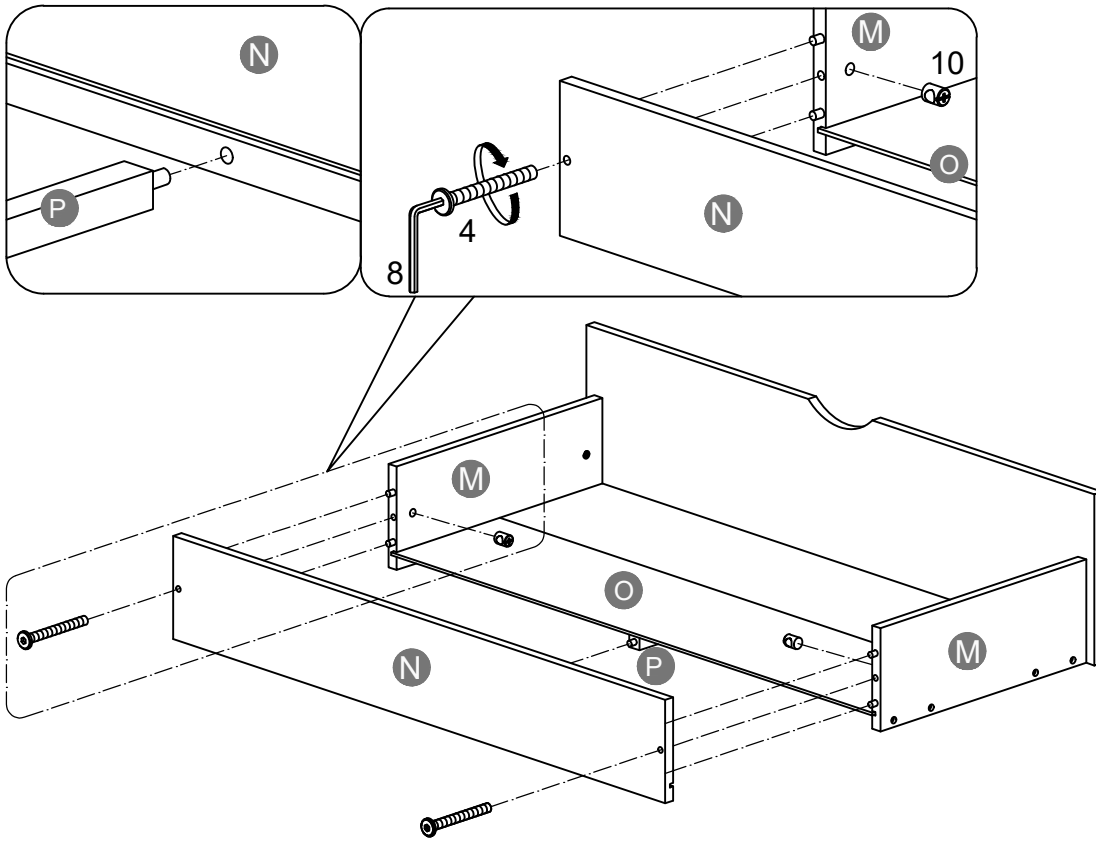

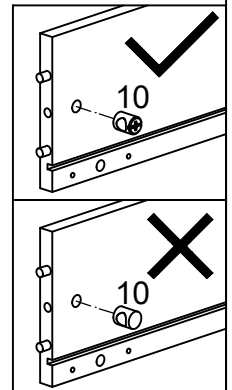

Note: Part 8 will face up with the "x" mark on it, otherwise it cannot be tightened



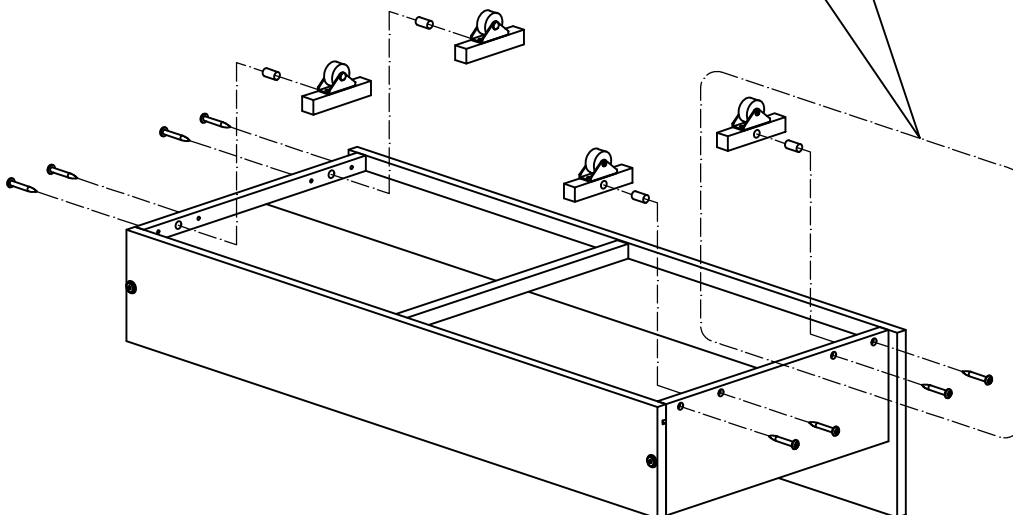
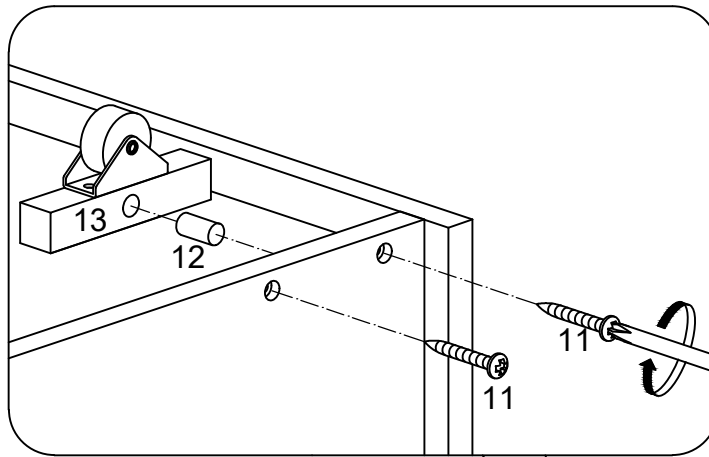

STEP 10:

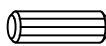

| | |
|-----------|---|
| 11 |  |
| 16 pcs | |
| 12 |  |
| 8pcs | |
| 13 |  |
| 8pcs | |

STEP 11:

| | |
|-----------|---|
| 4 |  |
| 3pcs | |
| 7 |  |
| 3pcs | |
| 14 |  |
| 3pcs | |

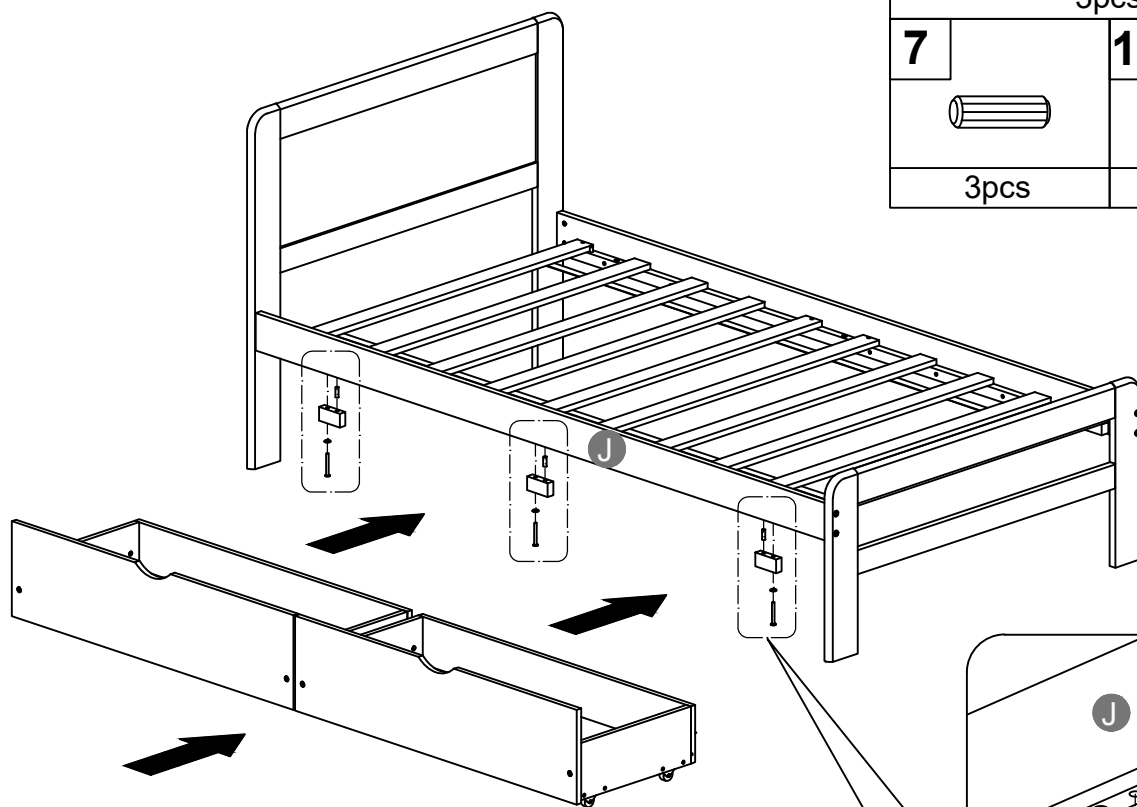

Push Drawers under the bottom of Bed.

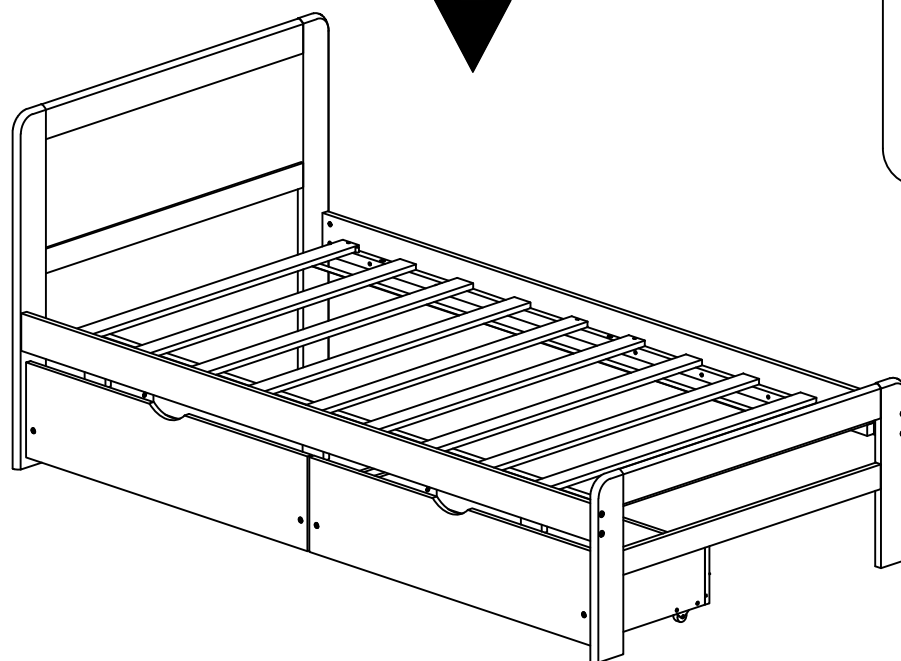
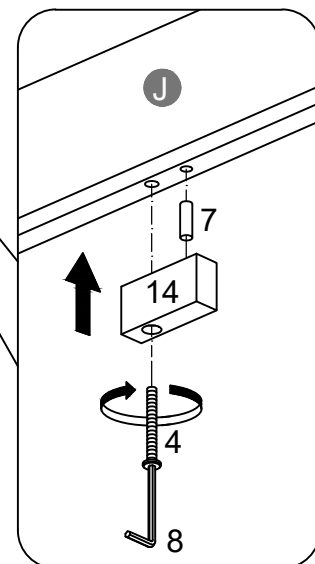

Make sure to tighten all the screws of the bed.