

# Barber Chair

OWNER'S MANUAL







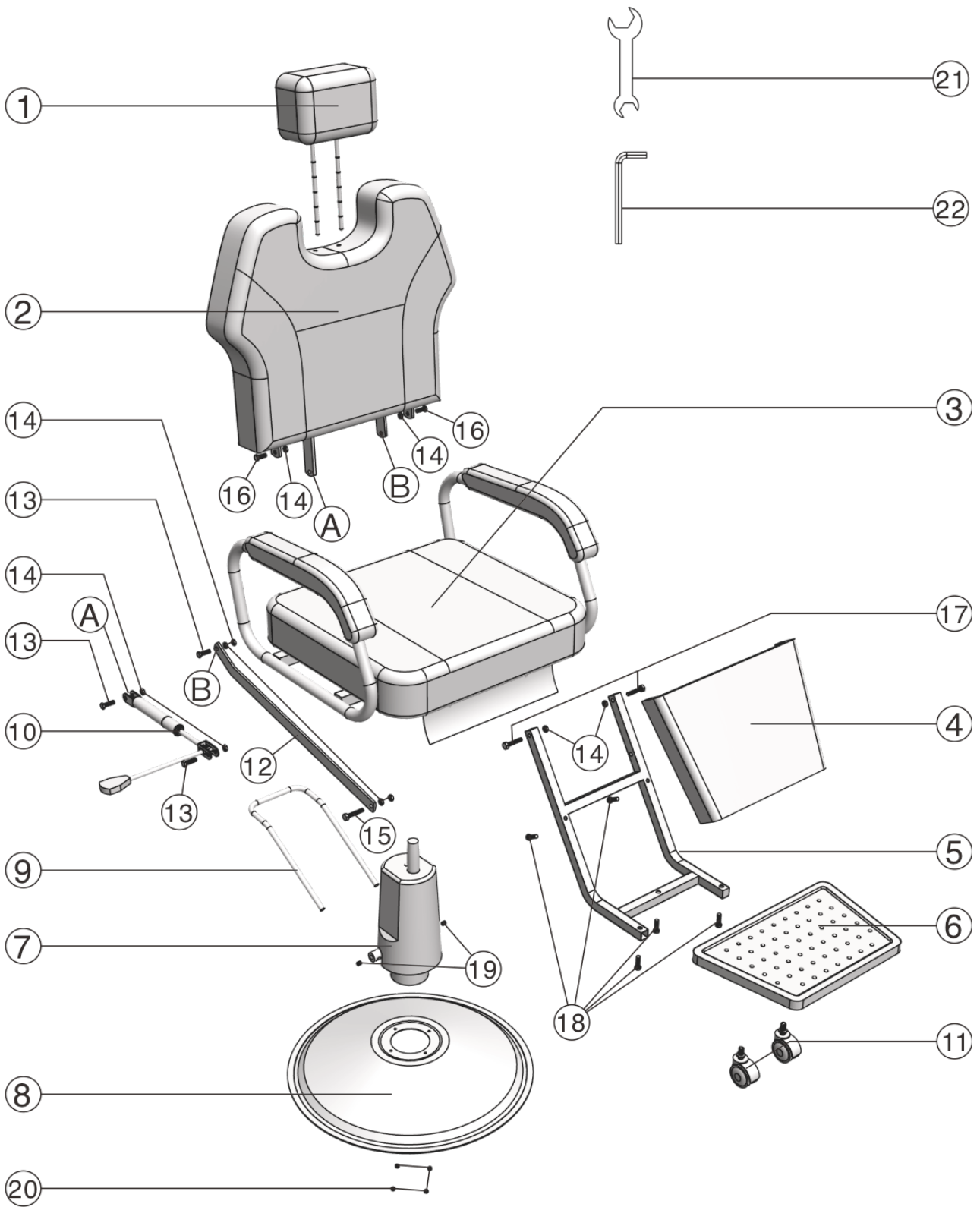



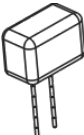
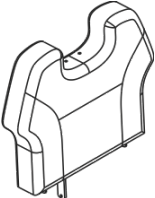
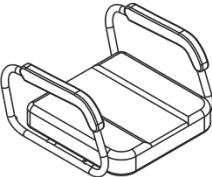
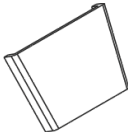
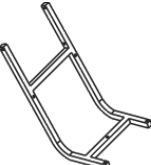

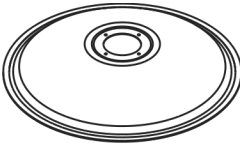
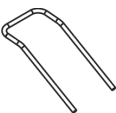

---





**CAUTION!** Please read through this manual before assembling, installing or using the product to ensure safe and correct use.



## Parts

Code	Image	Parts Name	Qty(Pcs)	Code	Image	Parts Name	Qty(Pcs)
1		Headrest	1	2		Backrest	1
3		Seat	1	4		Leg Rest	1
5		Frame	1	6		Footrest	1
7		Oil Pump	1	8		Base	1
9		Foot Pump Rod	1	10		Reclining Aerobar	1
11		Caster	2	12		Pull Rod	1
13		Hex Screw M8*30	3	14		Hex Nut M8	10
15		Hex Screw M8*45	1	16		Hex Screw M8*25	2
17		Hex Screw M8*40	2	18		Hex Screw M8*35	5
19		Lock Nut M8	2	20		Hex Nut M6	4

## Tools

Code	Image	Tools Name	Qty(Pcs)
15		Wrench	1
16		Allen Key	1

# Installation Diagram

## Step One:

Open the wooden box and take out the Oil Pump ⑦, unscrew the 4 Hex Nuts M6 ⑳ from the bottom of the Oil Pump ⑦ for later use.

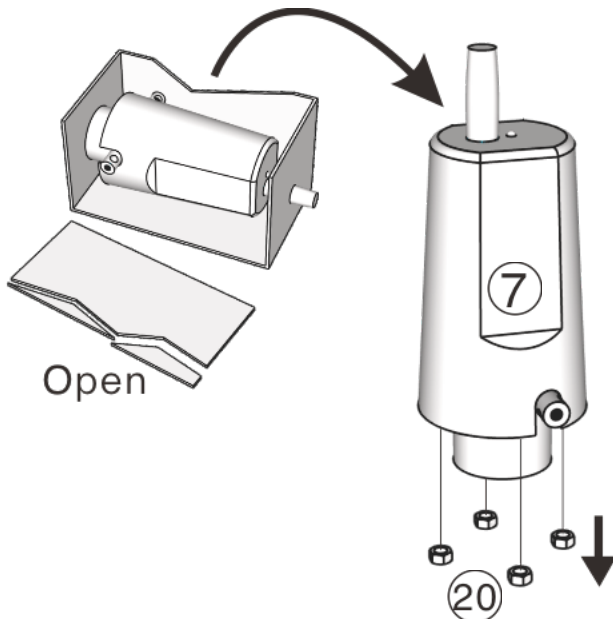

Four Hex Nuts M6 ⑳ were pre-installed on the bottom of the Oil Pump ⑦

## Step Two:

Install the Base ⑧ to the bottom of the Oil Pump ⑦ and tighten the 4 Hex Nuts M6 ⑳.

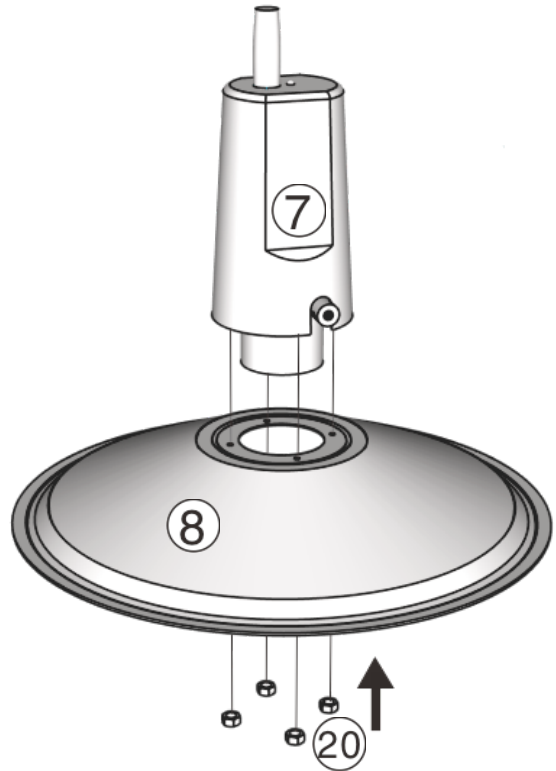

## Step Three:

Loosen the 2 Lock Nuts M8 ⑲, install the Foot Pump Rod ⑨ to the Oil Pump ⑦, and tighten the 2 Lock Nuts M8 ⑲ to fix the Foot Pump Rod ⑨.

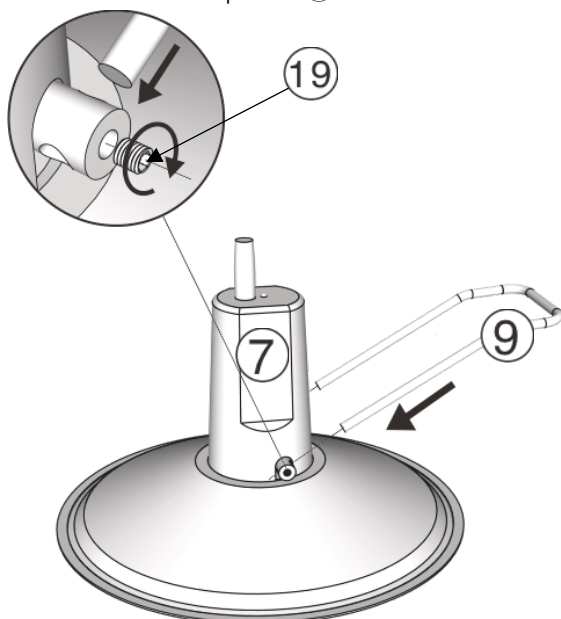

Two Lock Nuts M8 ⑲ were pre-installed on Oil Pump ⑦

## Step Four:

The Base ⑧ and Oil Pump ⑦ are installed and set aside for later use.

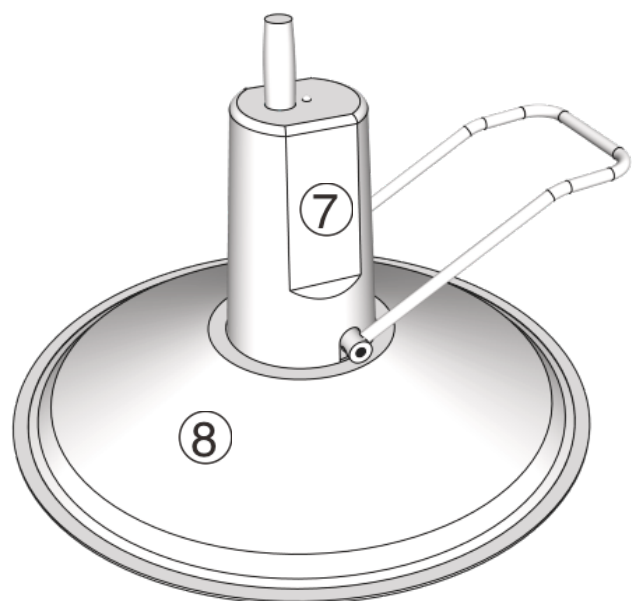

**Step Five:**

Install the two Casters (11) to the bottom of the Footrest (6) and tighten the screws.

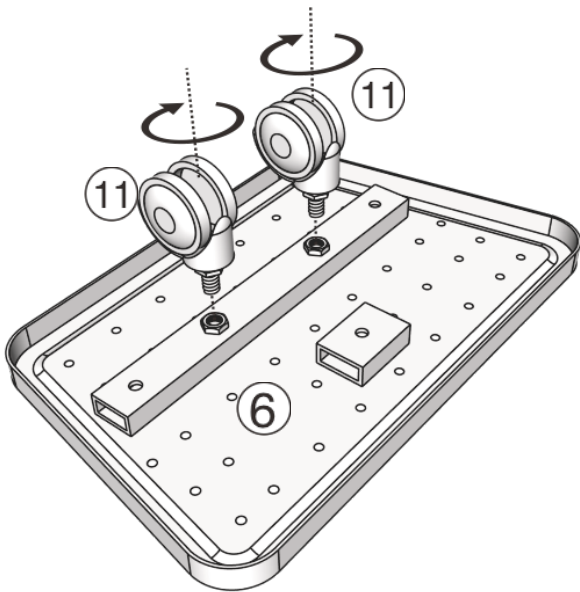

Two Casters (11) were packed in the accessory kit (a small bag)

**Step Six:**

Attach the Footrest (6) and Leg Rest (4) to the Frame (5) and secure them with five Hex Screws M8\*35 (18).

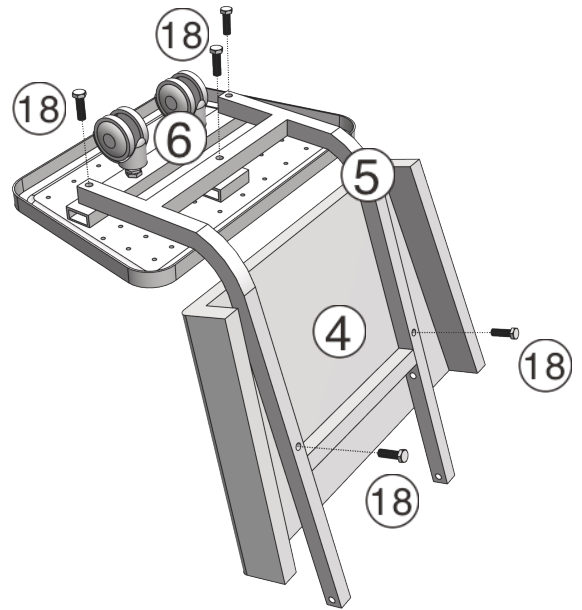

Five Hex Screws M8\*35 (18) were packed in the accessory kit (a small bag)

**Step Seven:**

Connect the Backrest (2) and Seat (3) with 2 Hex Screws M8\*25 (16) and Hex Nuts M8 (14).

At the bottom of the Seat (3), install the Reclining Aerobar (10) and secure the Reclining Aerobar (10) with 2 Hex Screws M8\*30 (13) and Hex Nuts M8 (14).

**Attention:** The A end of the Reclining Aerobar (10) is connected to the A end of the Backrest (2).

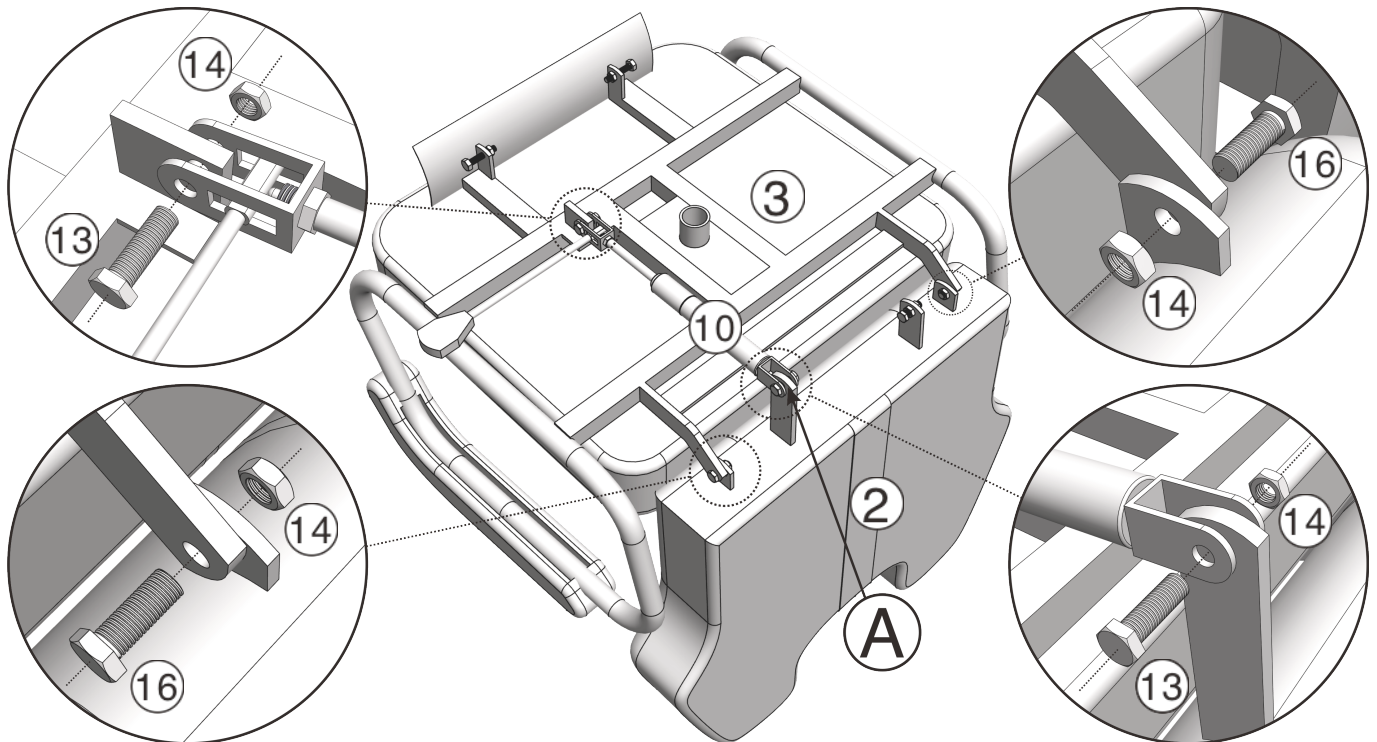

Two Hex Screws M8\*25 (16) and two Hex Nuts M8 (14) were pre-installed on the Backrest (2)

Two Hex Screws M8\*30 (13) and two Hex Nuts M8 (14) were pre-installed on the Reclining Aerobar (10)

**Step Eight:**

Attach the Frame (5) to the bottom of the Seat (3) and secure the Pull Rod (12), insert the covering leather into the gap behind the Frame (5). **Attention:** The B end of Pull Rod (12) is connected to the B end of the Backrest (2).

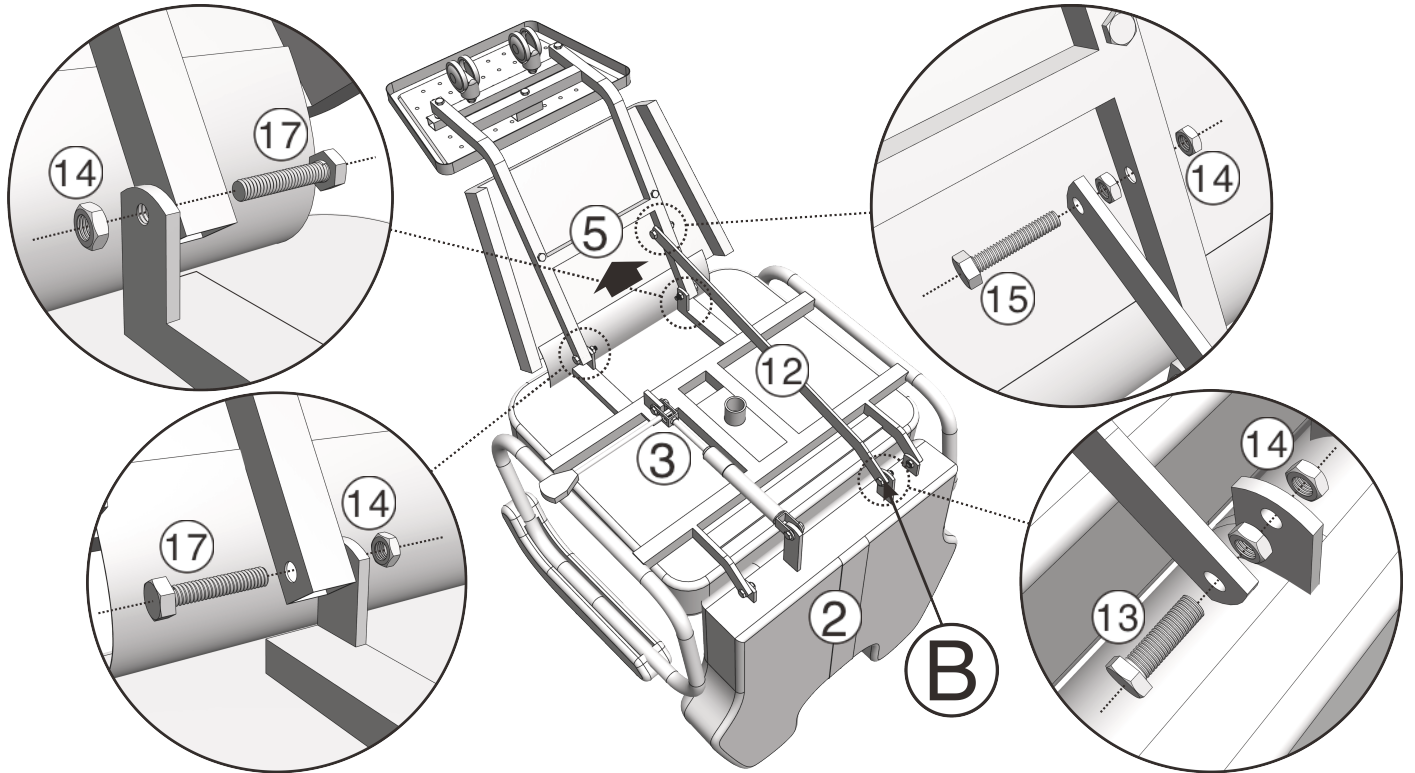

Two Hex Screws M8\*40 (17) and two Hex Nuts M8 (14) and one Hex Screw M8\*45 (15) and one Hex Nut M8 (14) were pre-installed on the Frame (5)

One Hex Screw M8\*30 (13) and one Hex Nut M8 (14) were pre-installed on the Backrest (2)

**Step Nine:**

Combine the Seat: Attach the assembled seat to the pump, sit on it, insert the Headrest (1) and there you go.

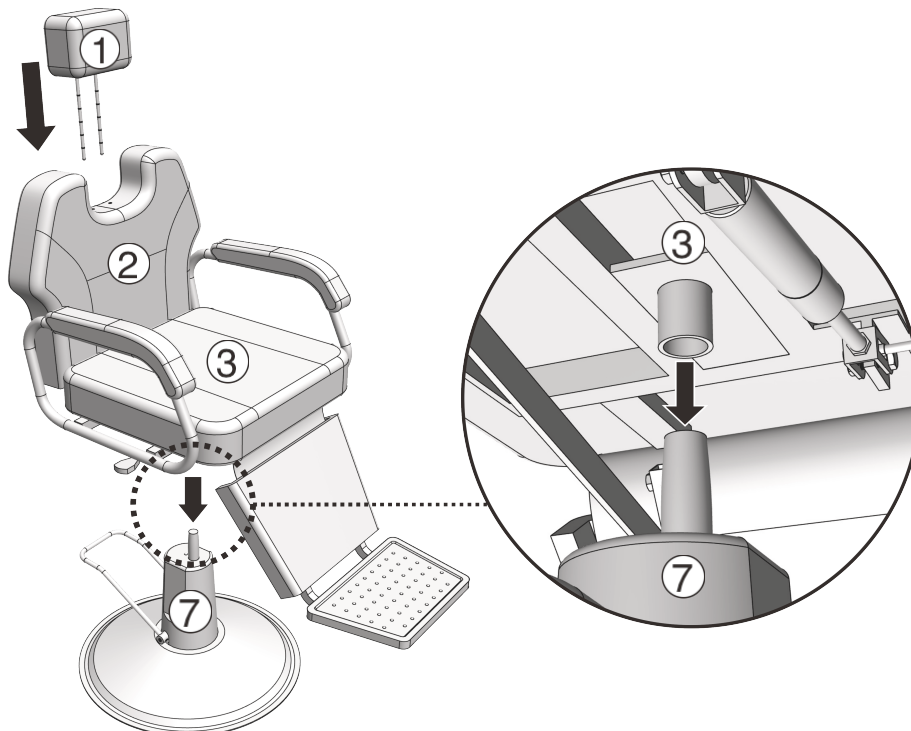

## Instruction for use



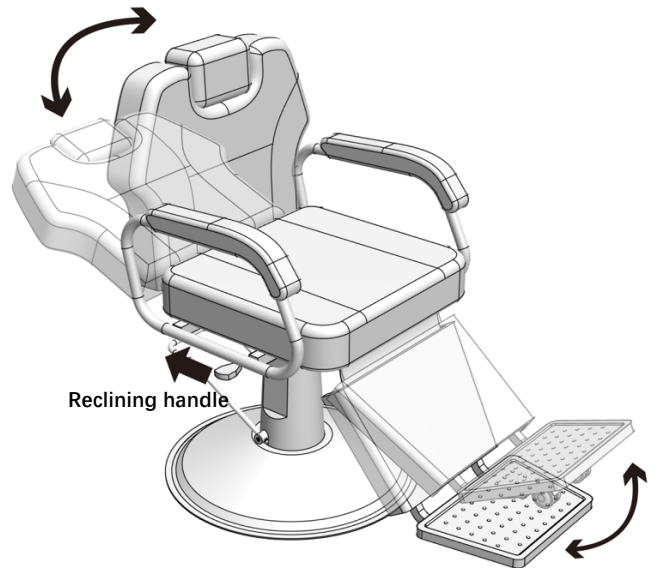

**The height of the headrest:** The height of the headrest can be adjusted by pulling and pushing up and down the headrest.



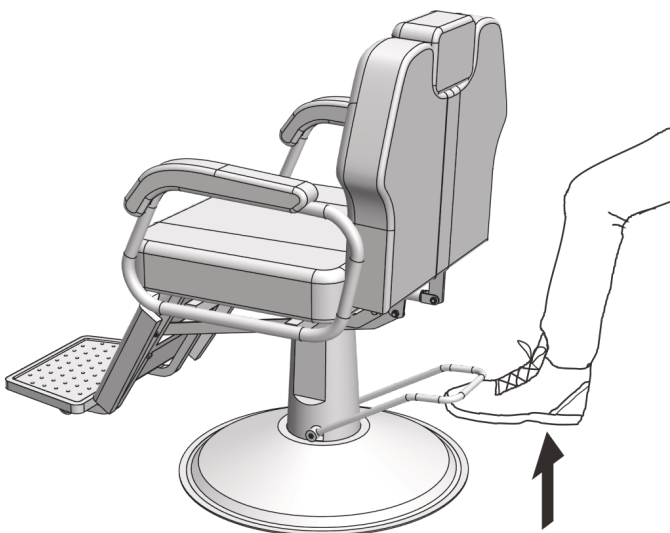

**Reclining the backrest, lifting the footrest and leg rest:** Sit down in the chair and pull the reclining handle on the right side of the seat backwards without letting go of it. Release the reclining handle at the desired angle, the backrest and footrest secured.

**Backrest rebounds upright, footrest and leg rest are aligned:** The body returns to upright, pull the reclining handle on the right side of the seat back again, the backrest rebounds upright, and the footrest and leg rest are aligned.

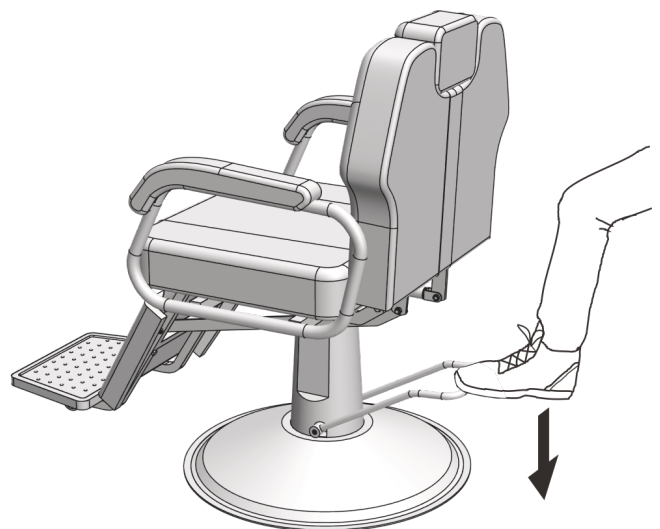

 **Lock:** Lift the foot pump rod upward, and the rotation and lifting functions are locked.



 **Unlock:** Press the foot pump rod down, and the rotation and lift functions resume.

**Seat up:** Foot down on the foot pump rod 5-10 cm, and repeat. Don't step too deep!

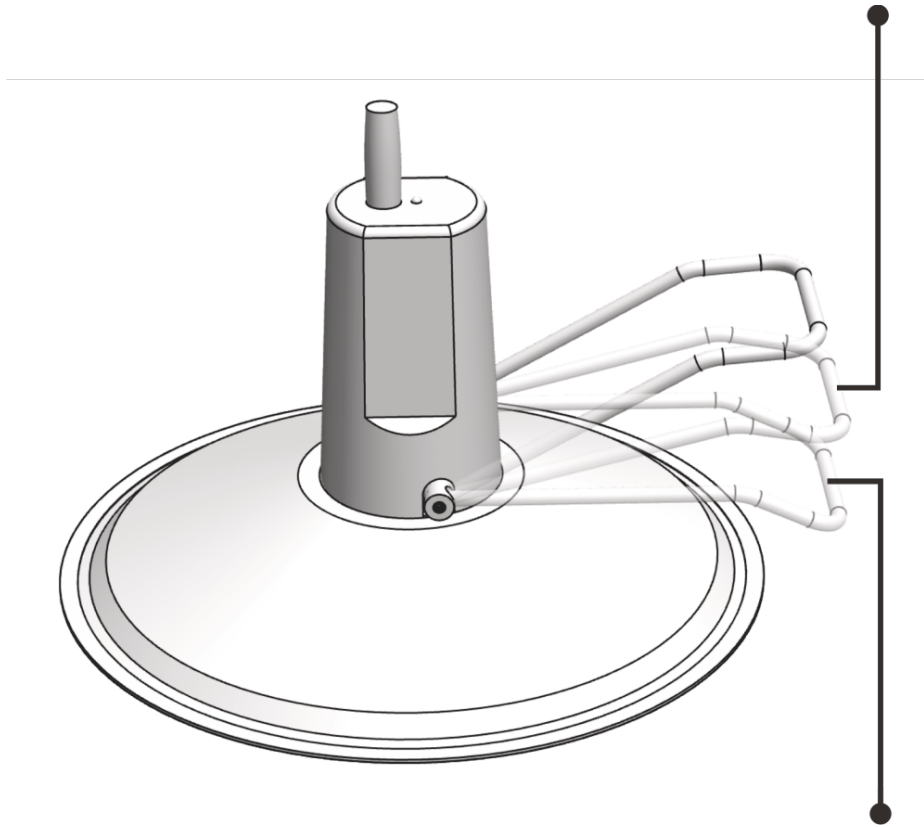

**Seat down:** Downhill the foot pump rod and hold still to lower the seat.