

# ASSEMBLY INSTRUCTIONS

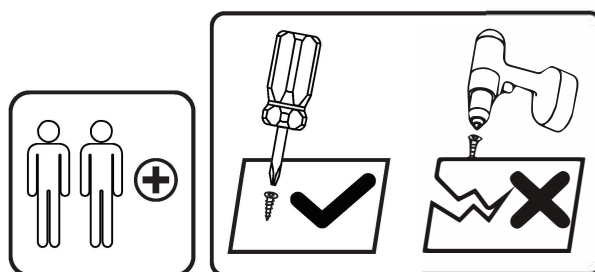

## Tools Recommended

THIS INSTRUCTIONS CONTAINS IMPORTANT SAFETY INFORMATION.  
PLEASE READ BEFORE ASSEMBLY AND KEEP FOR FUTURE REFERENCE.

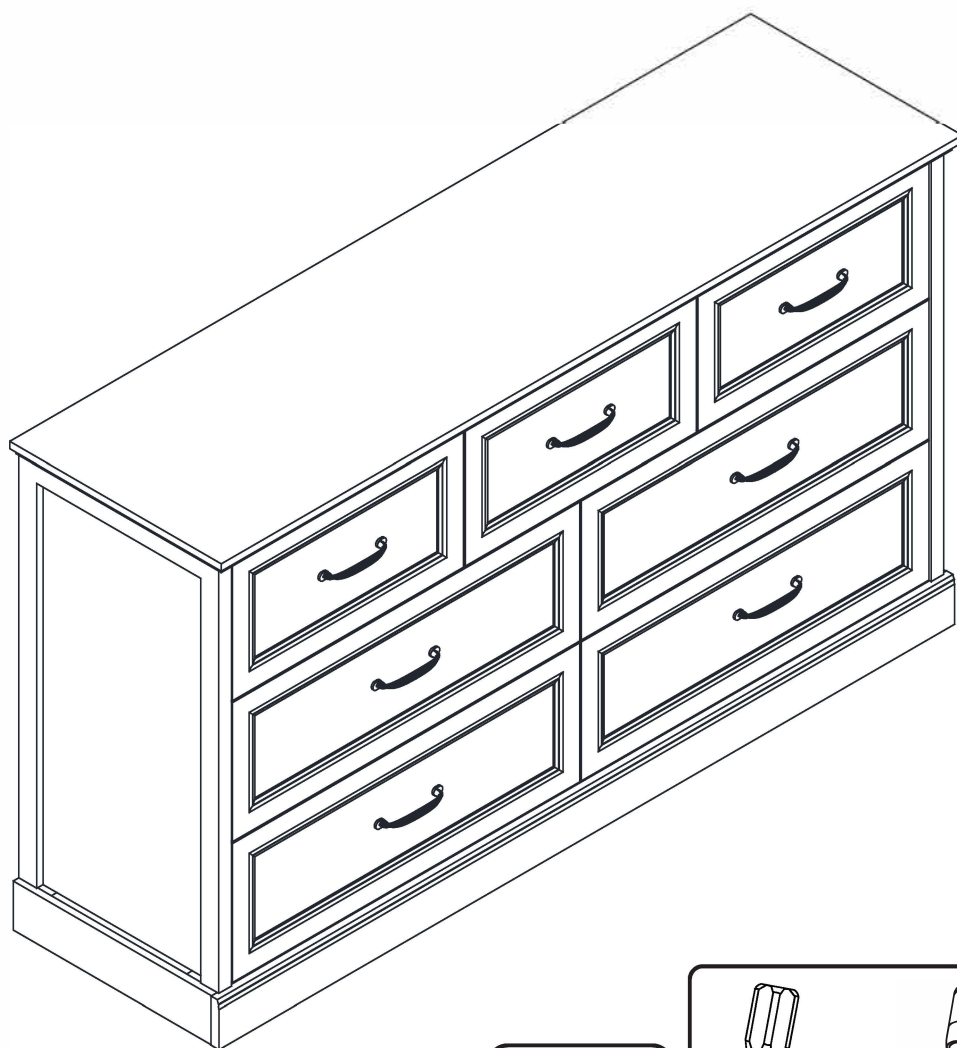
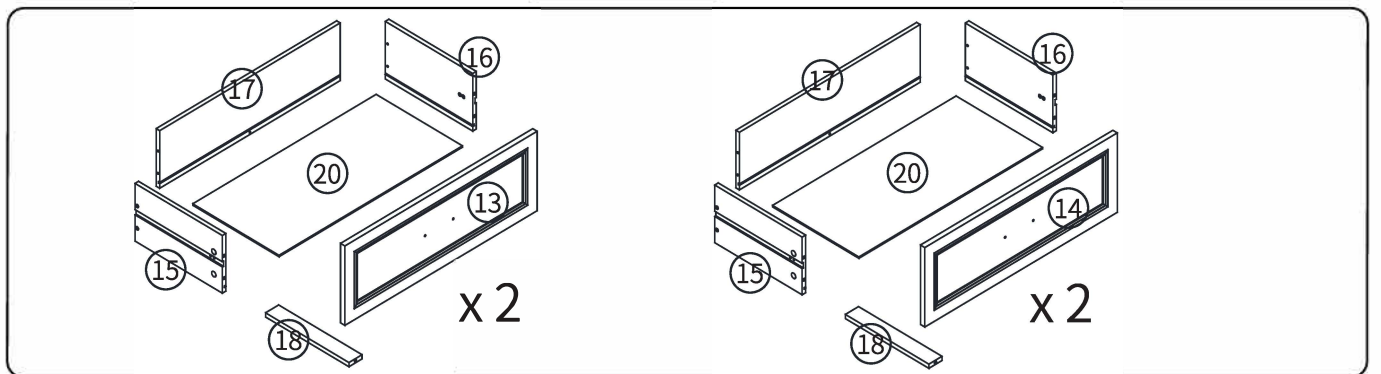
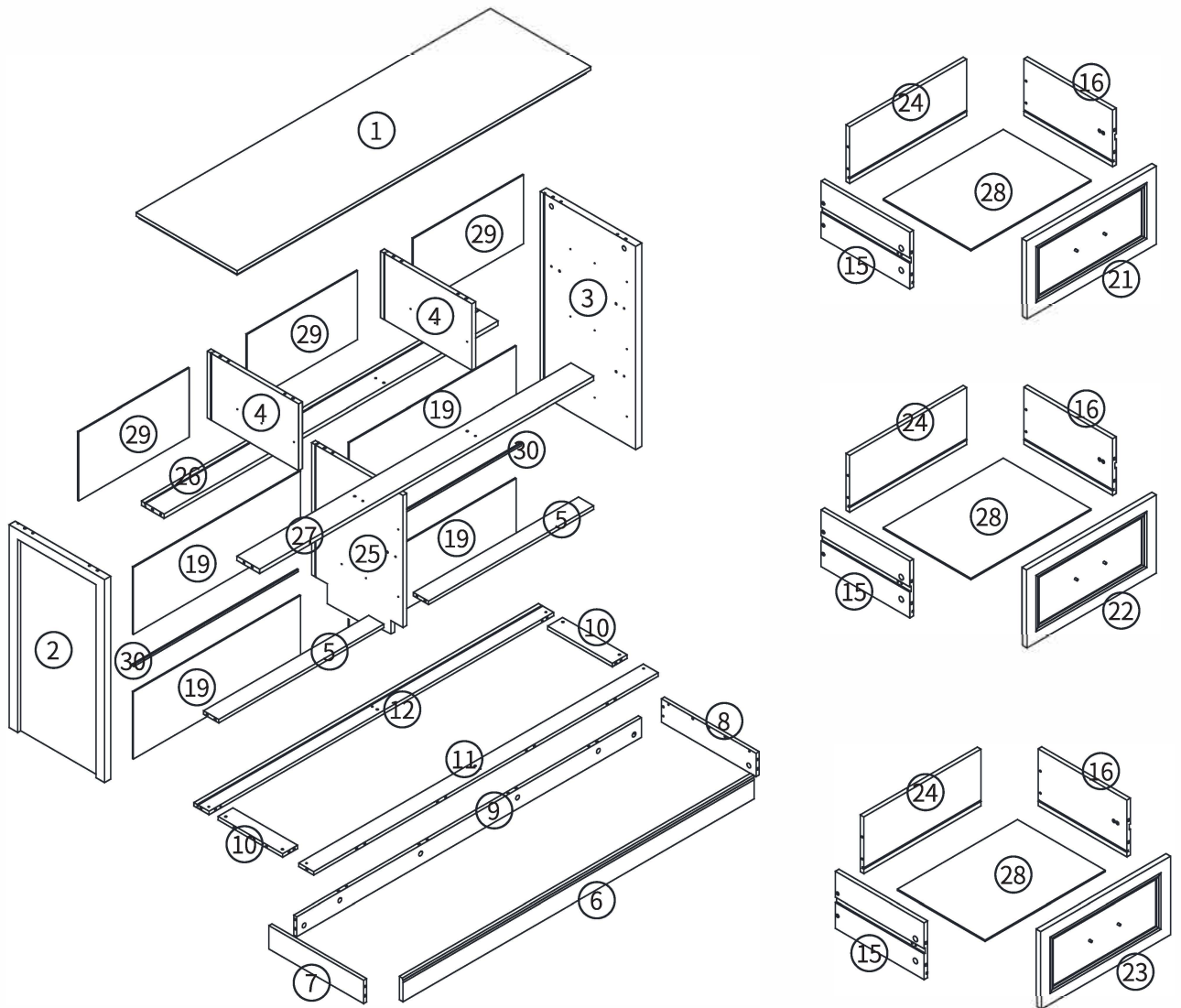

The installation direction should be aligned with the instructions to prevent plate breakage caused by product tipping during installation

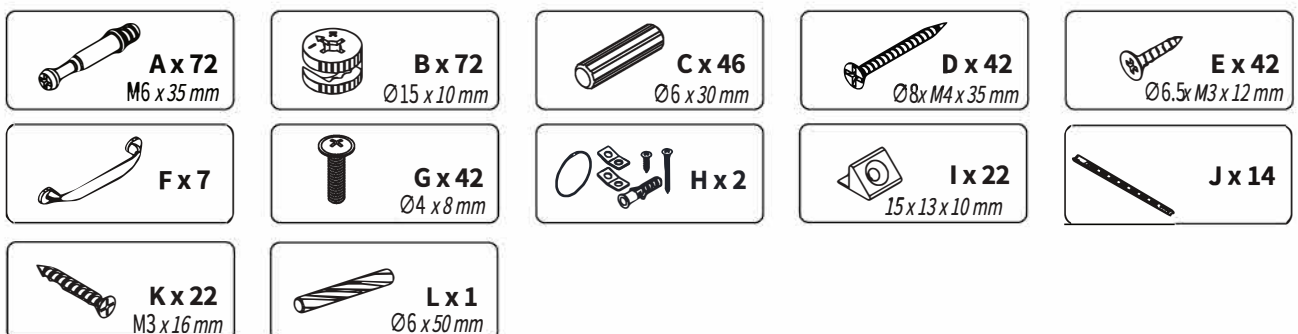

## Step 1

Insert screws(A) into corresponding holes in part ① as shown.

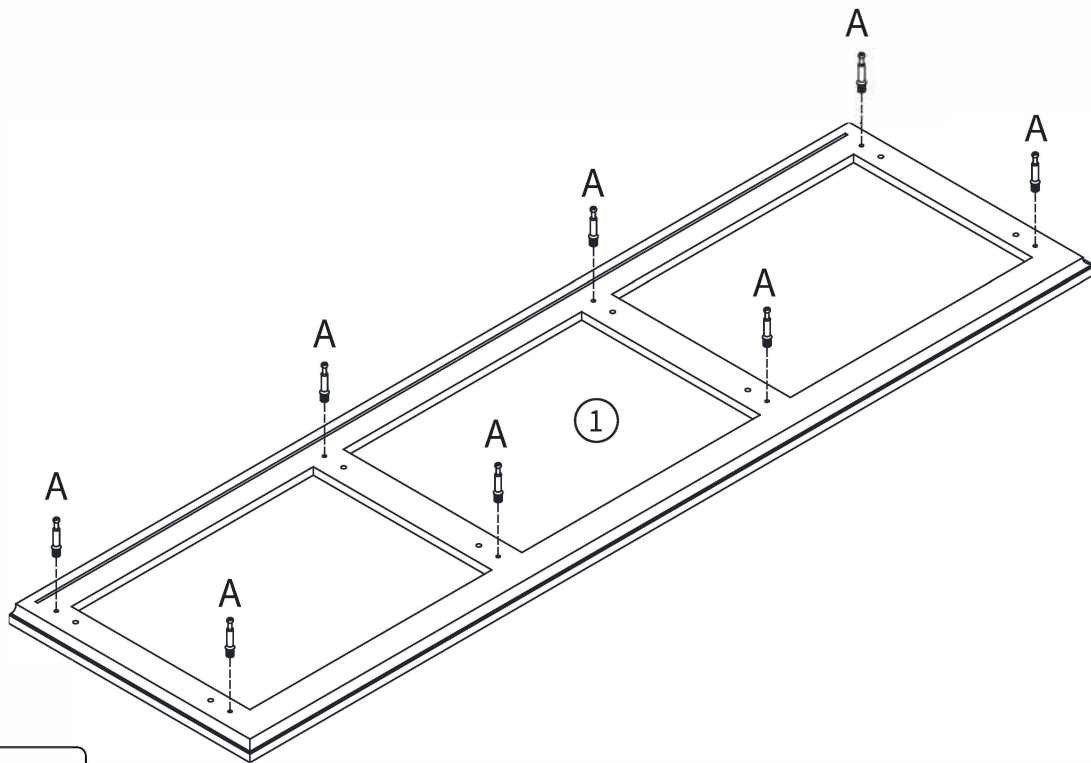

## Step 2

Insert screws(A) into corresponding holes in part ②⑦ as shown.

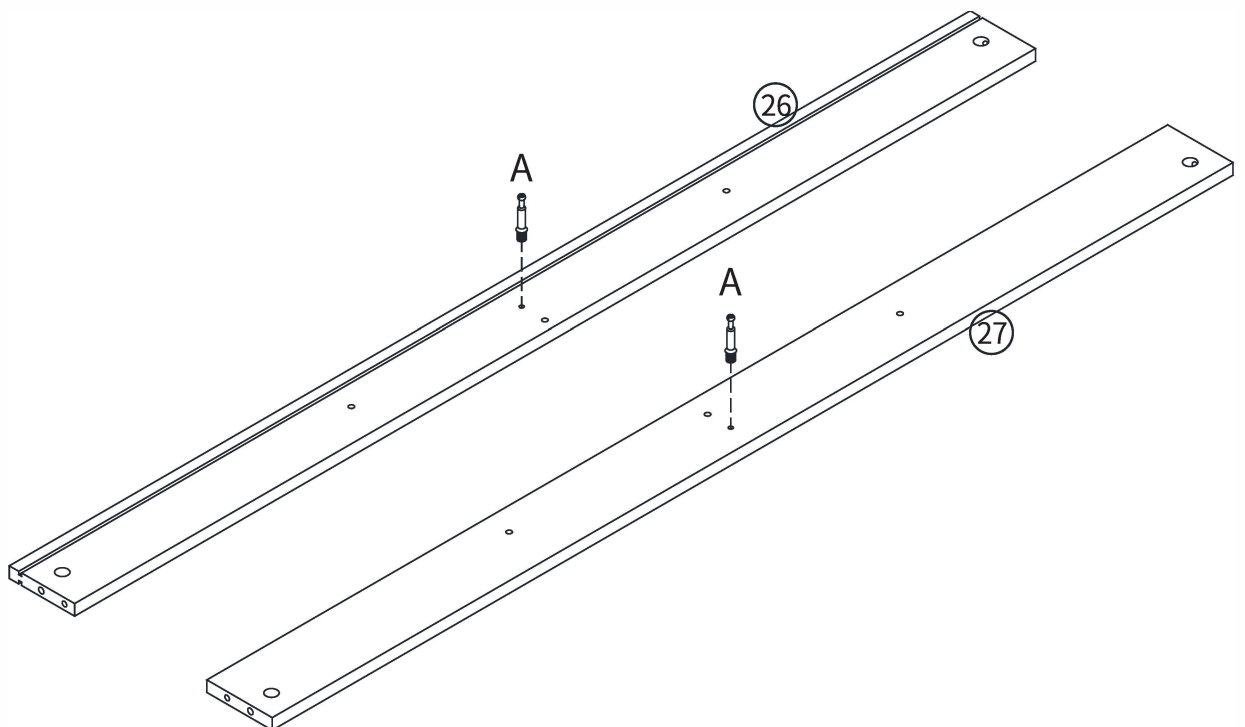

### Step 3

Insert screws(A) into corresponding holes in part ⑥ ⑪ ⑩ as shown.

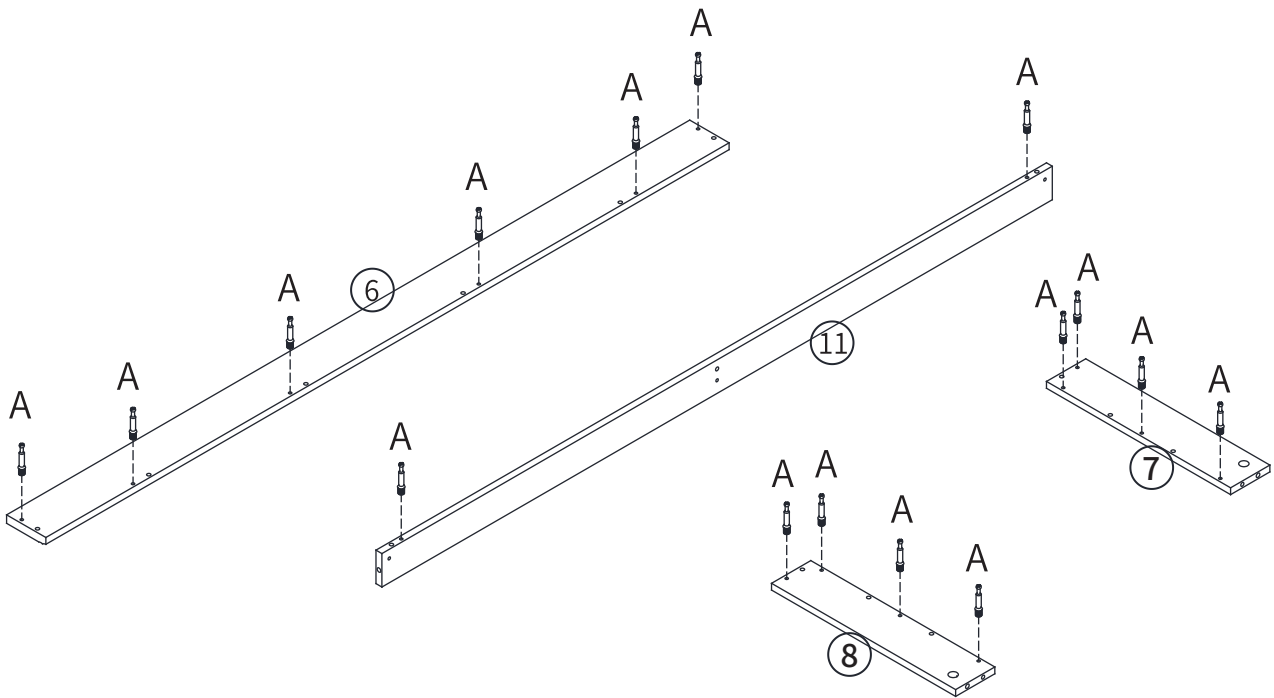

### Step 4

Insert screws(A) into corresponding holes in part ⑫ as shown.

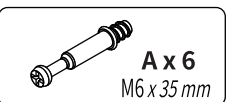
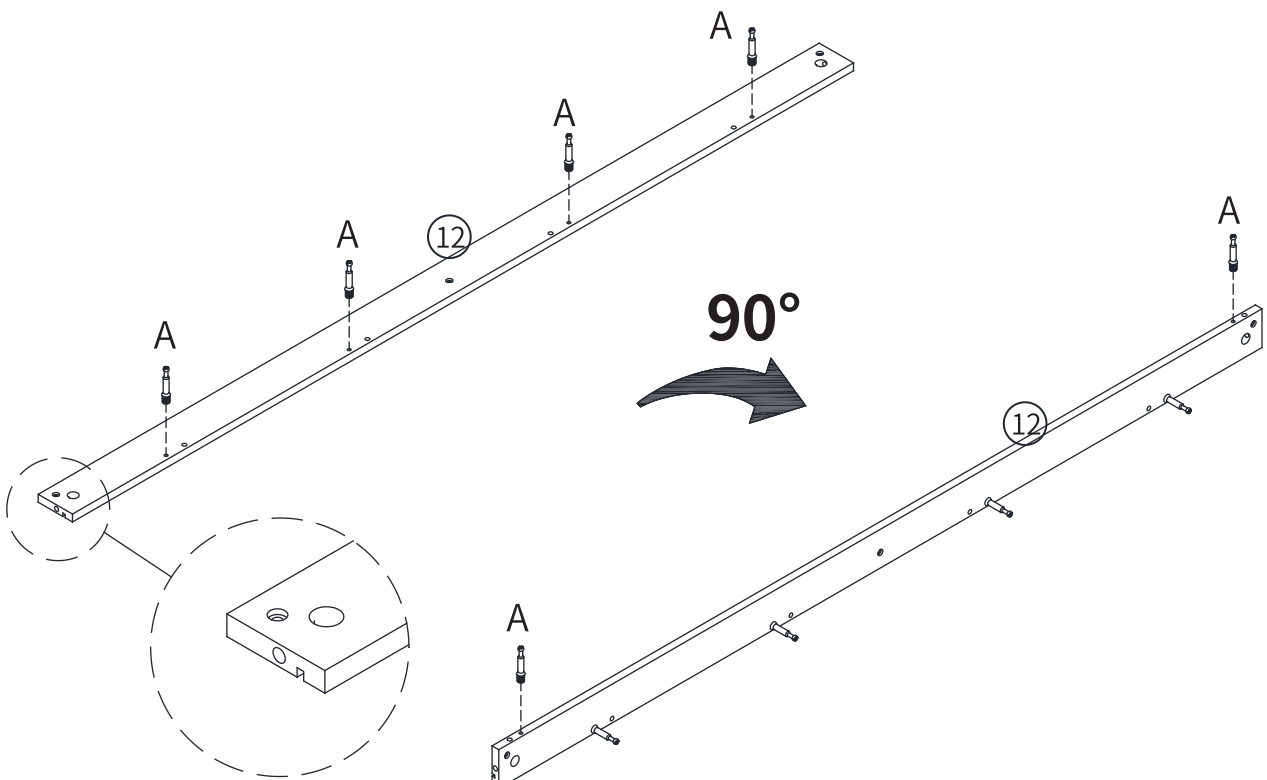

# Step 5

Fix outer drawer runner (J) to parts ④ using screws (E) as shown

Note: part ④ has two panels

# x 2

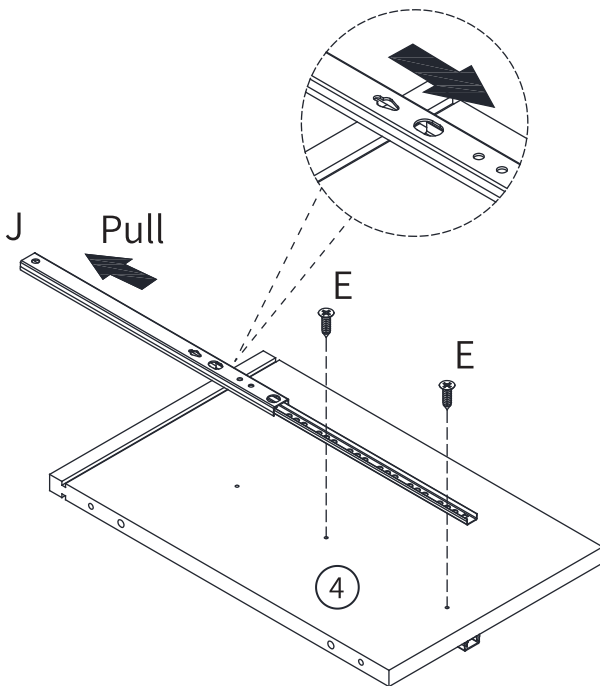
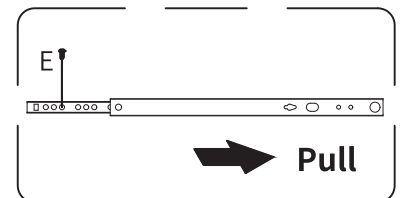
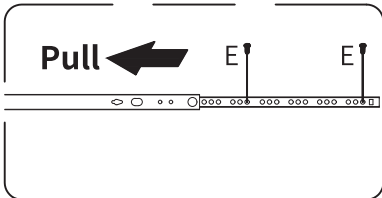
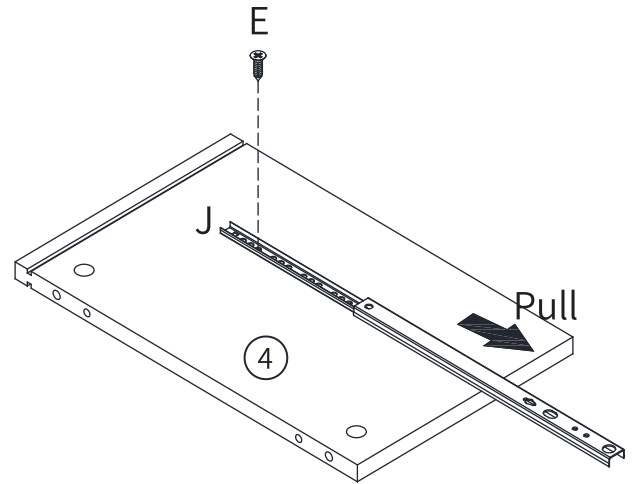
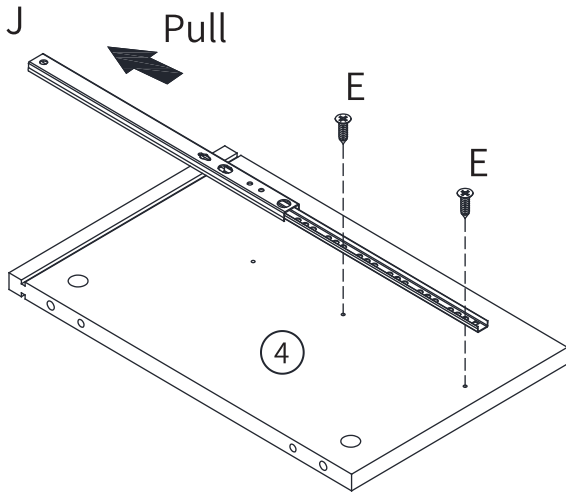

# 180°

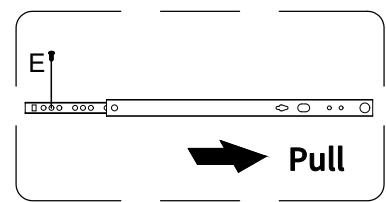
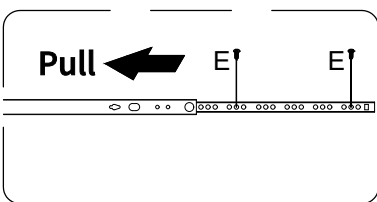
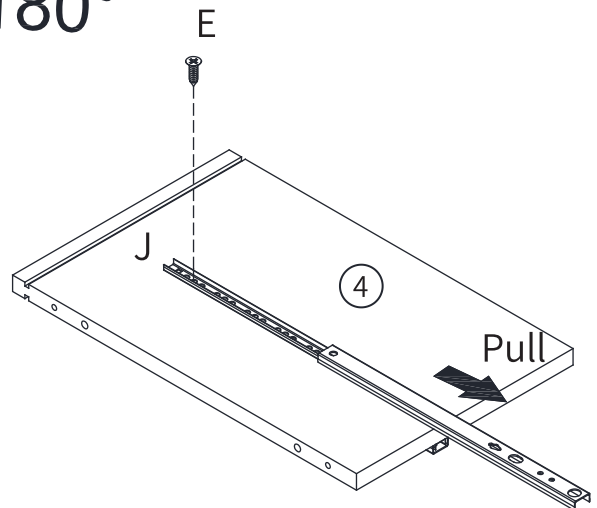

# Step 6

Fix outer drawer runner (J) to parts (25) using screws (E). Insert screws (A) into corresponding holes in part (25)

Part#25 is only one piece.

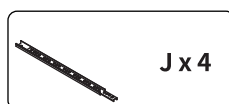
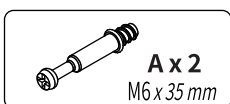
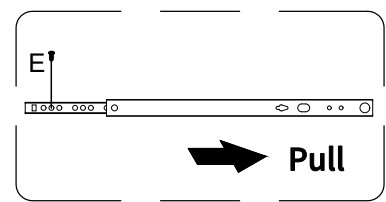
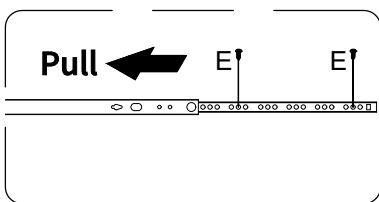
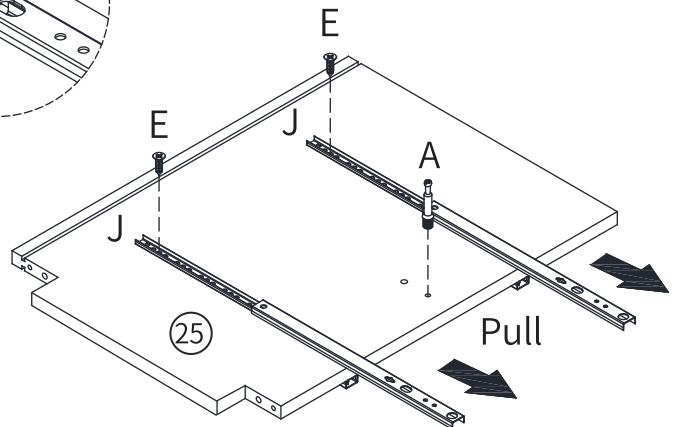
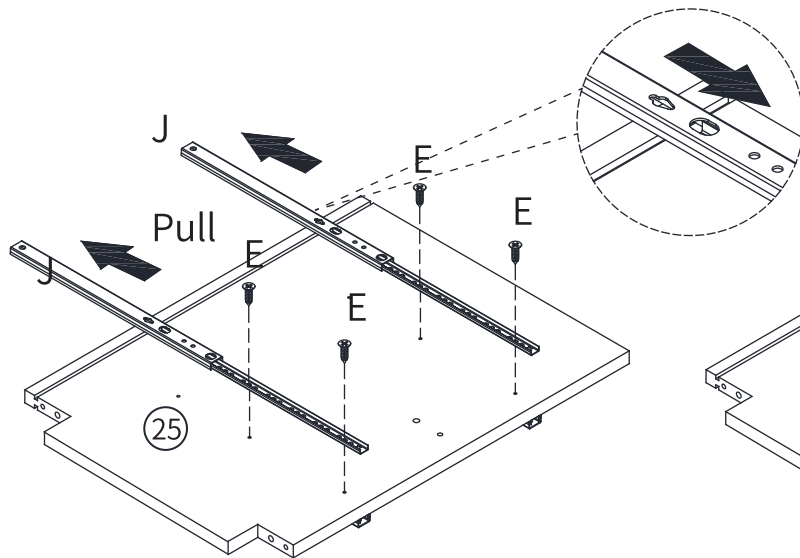
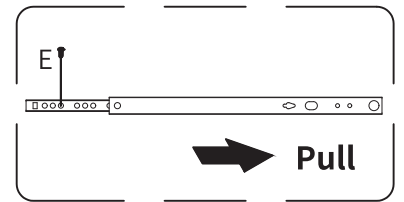
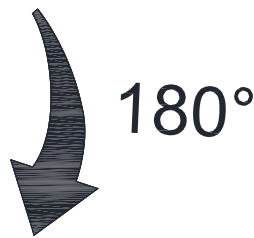
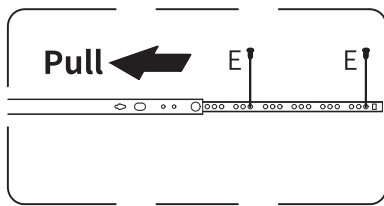
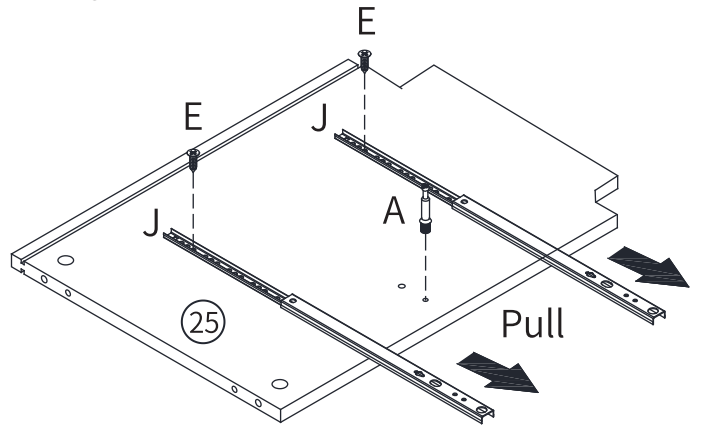
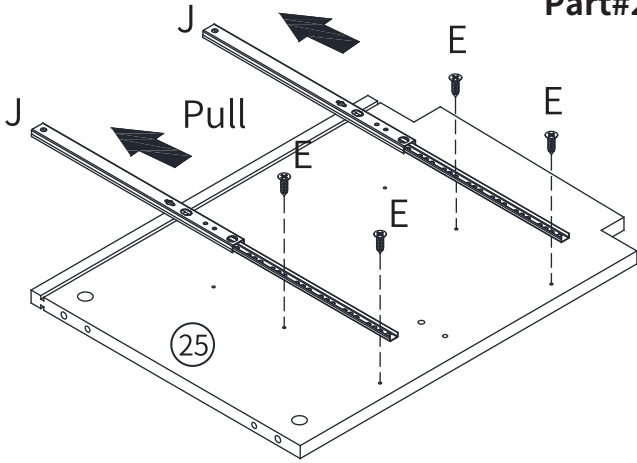

# Step 7

Insert as shown. fix outer drawer runner (J) to parts ② ③ using screws (E) .Insert screws(A) into corresponding holes in part ② ③ as shown

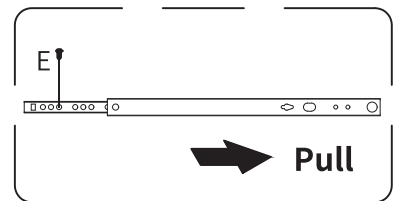
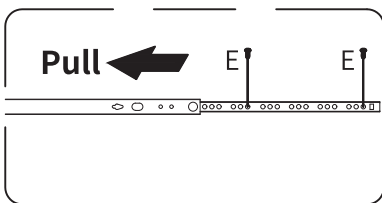
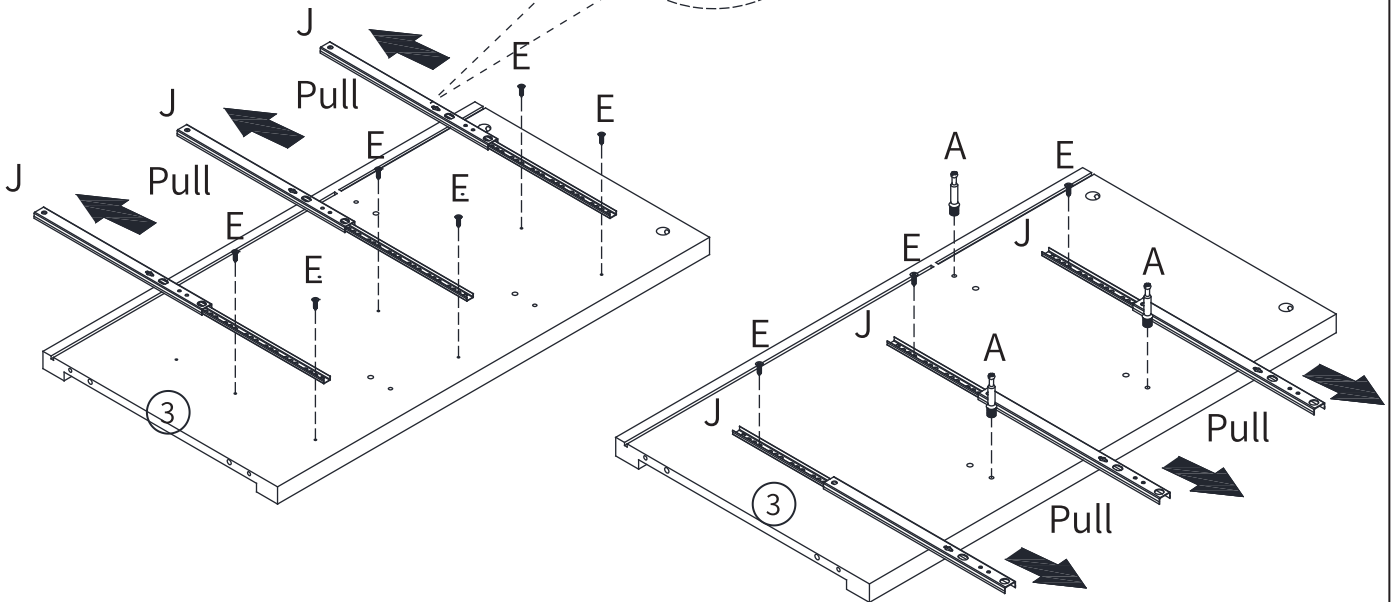
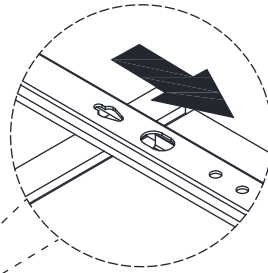
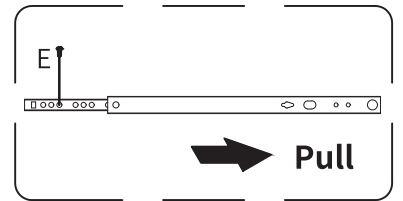
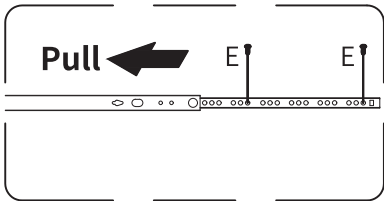
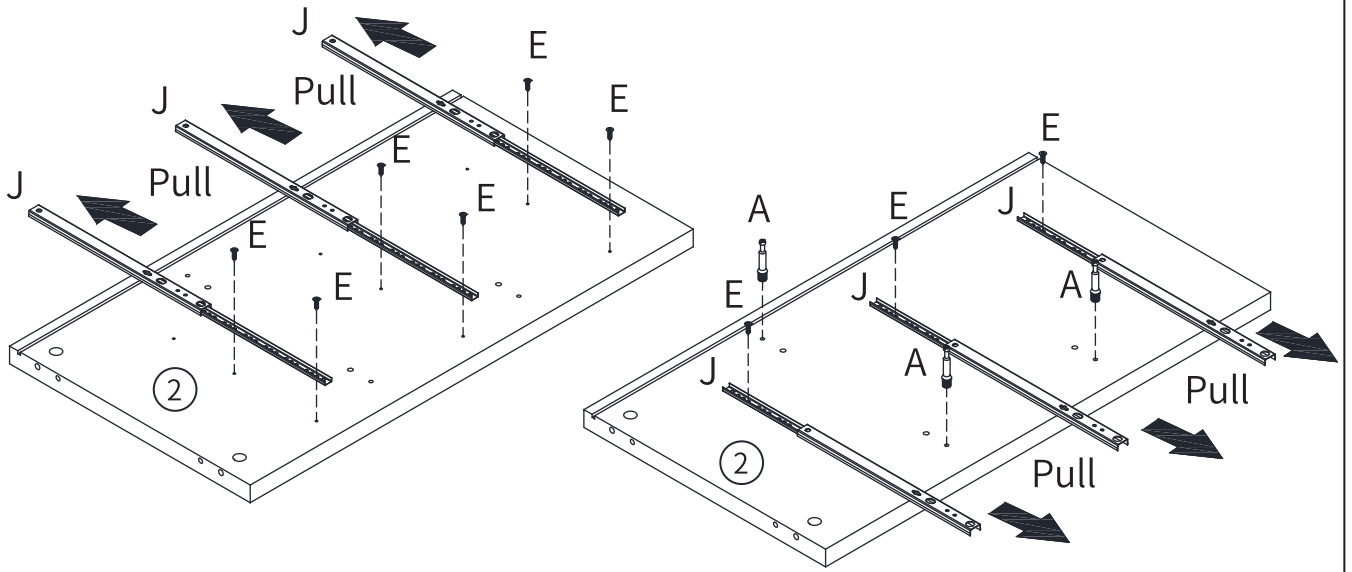

## Step 8

Insert wooden dowel (C) on part (4), connect part (26) to part (4) with screw(D)

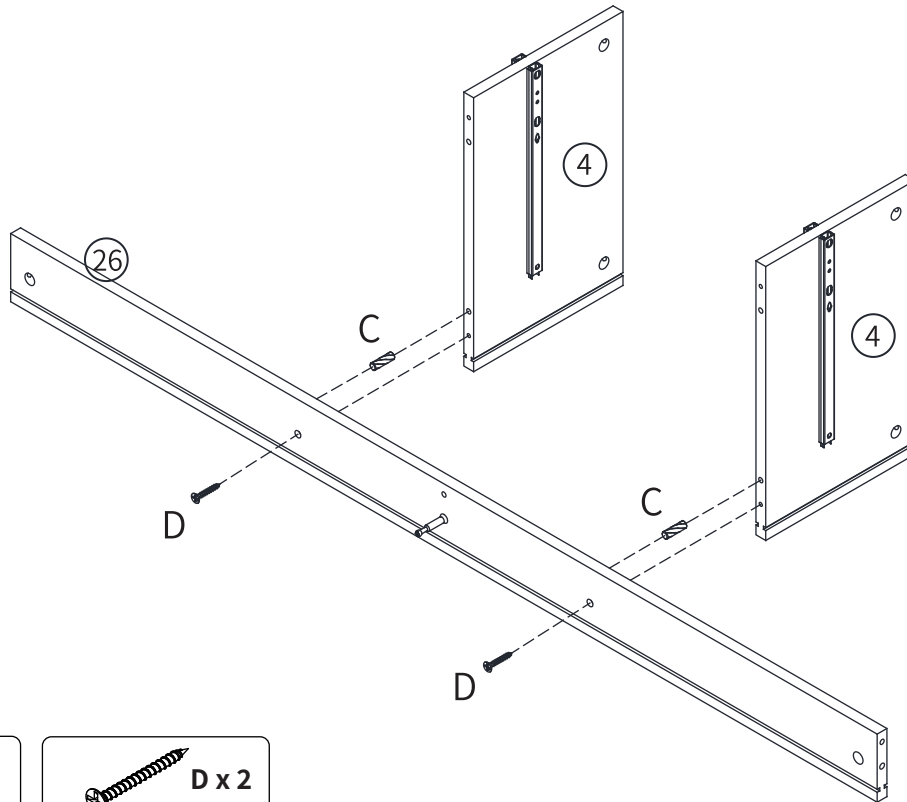

## Step 9

Insert wooden dowel (C) on part (4), connect part (27) to part (4) with screw(D)

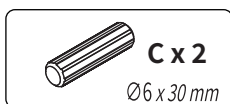
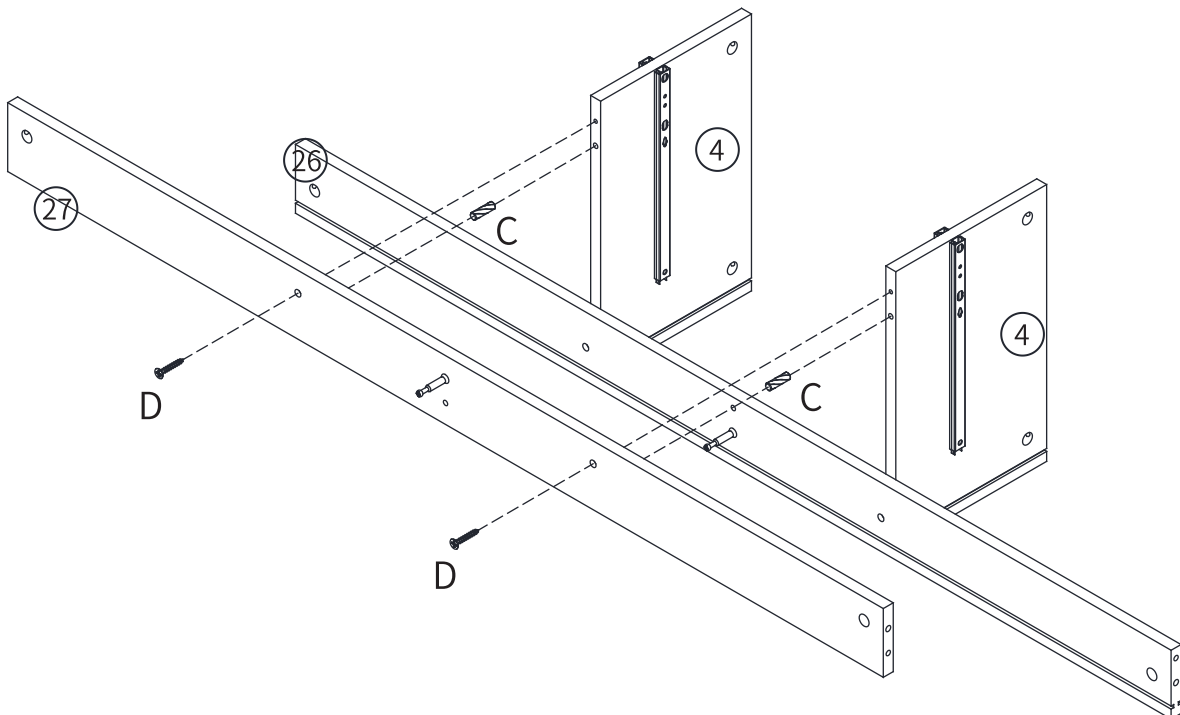

## Step 10

Insert wooden dowel (C) on part (26) & (27), connect part (25) to part (26) & (27) with eccentric wheels (B). Put the eccentric wheels (B) into the corresponding holes on part (25) and use a screwdriver to turn it clockwise to tighten, the installation position is as shown.

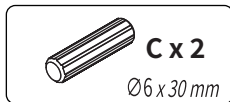
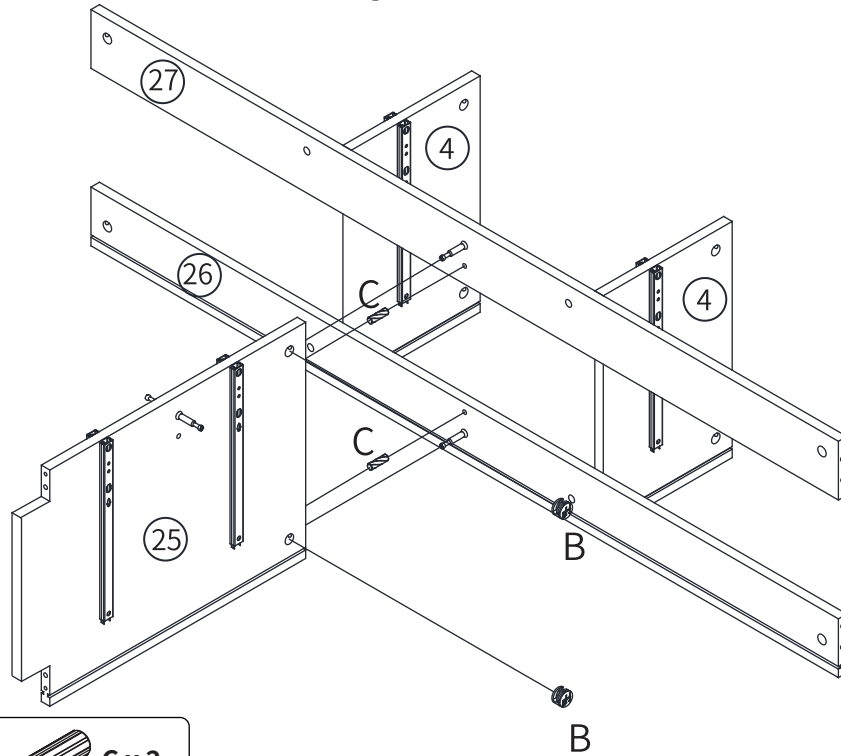

## Step 11

Insert wooden dowel (C) on part (25), connect part (5) to part (25) with eccentric wheels (B). Put the eccentric wheels (B) into the corresponding holes on part (5) and use a screwdriver to turn it clockwise to tighten, the installation position is as shown.

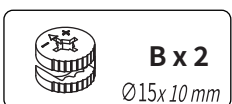
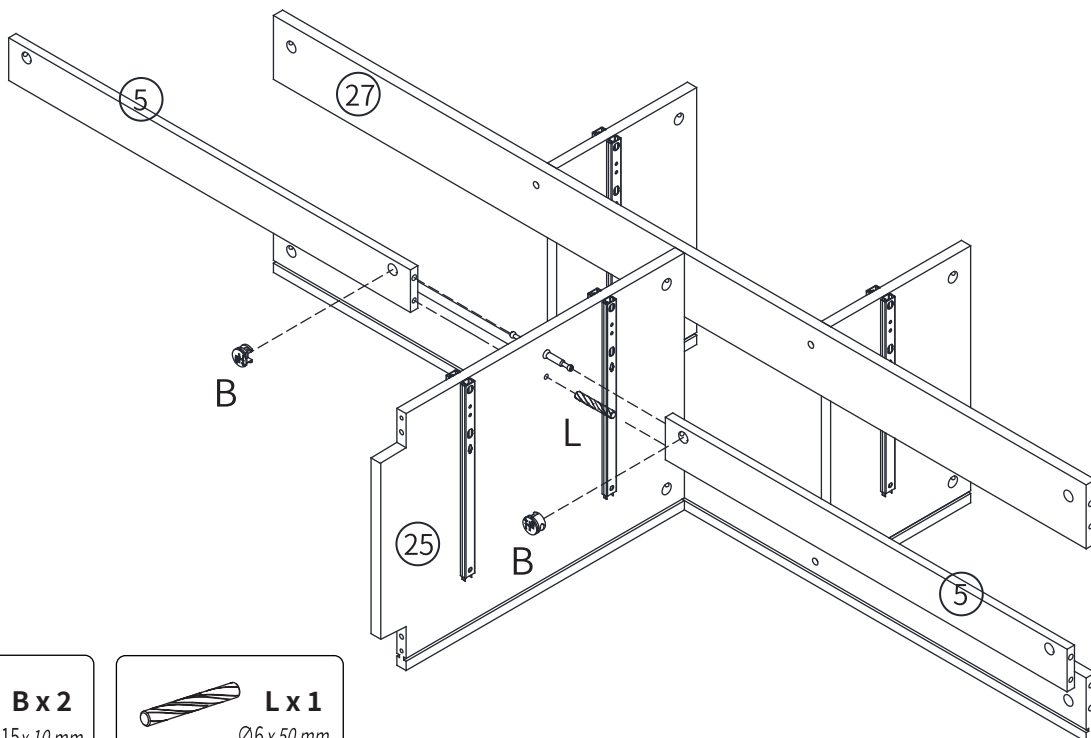

**Step 12** Insert wooden dowel (C) on part ②, connect part ⑤ & ②⑥ & ②⑦ to part ② with eccentric wheels (B). Put the eccentric wheels (B) into the corresponding holes on part ⑤ & ②⑥ & ②⑦ and use a screwdriver to turn it clockwise to tighten, the installation position is as shown.

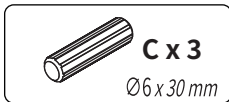
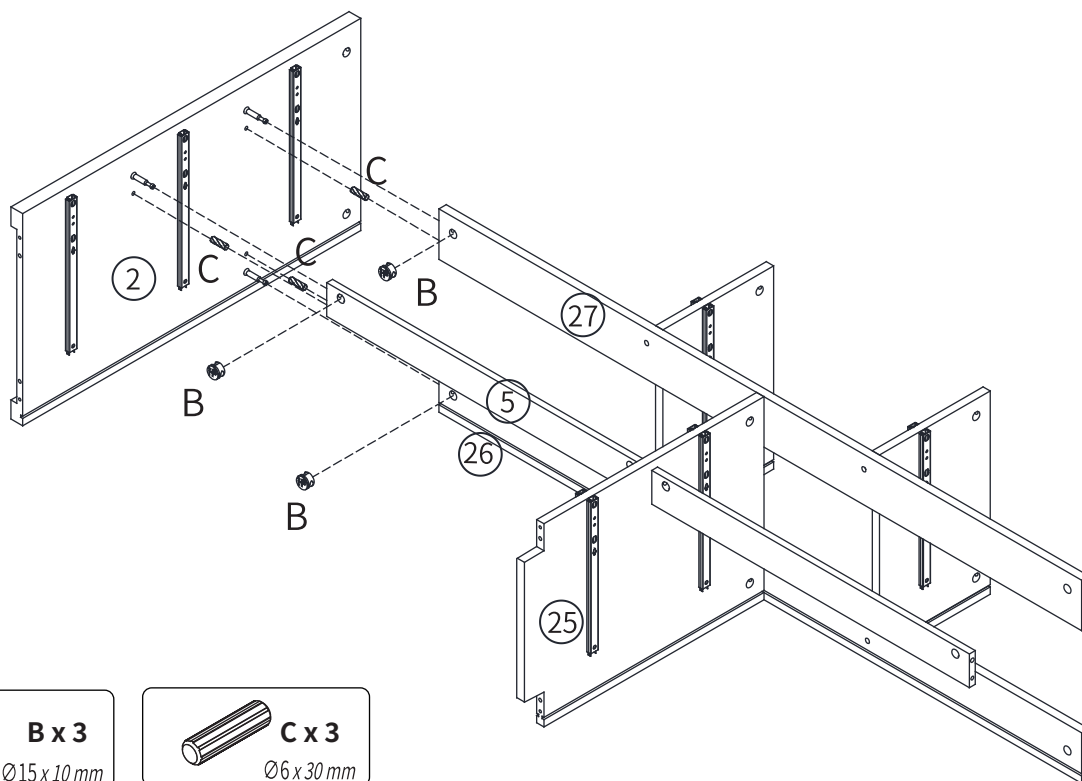

**Step 13** Insert wooden dowel (C) on part ③, connect part ⑤ & ②⑥ & ②⑦ to part ③ with eccentric wheels (B). Put the eccentric wheels (B) into the corresponding holes on part ⑤ & ②⑥ & ②⑦ and use a screwdriver to turn it clockwise to tighten, the installation position is as shown.

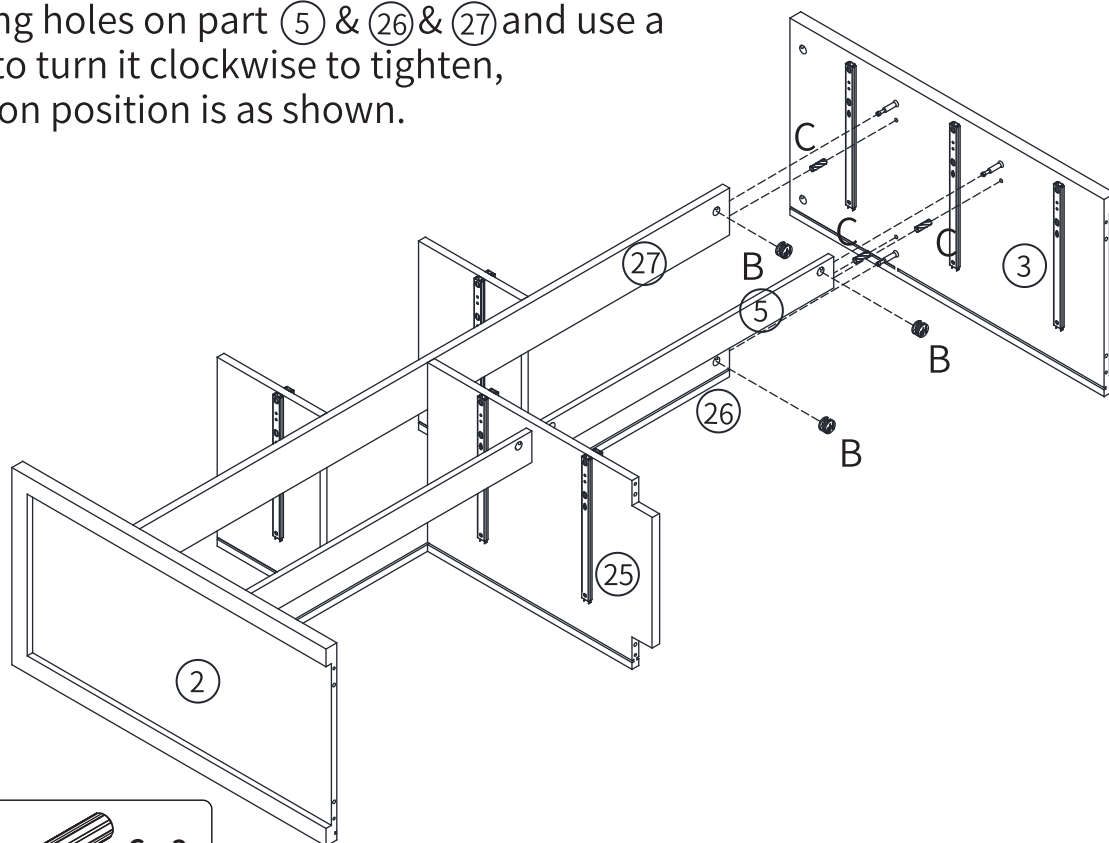

## Step 14

Insert wooden dowel (C) on part ⑩, connect part ⑪ ⑫ to part ⑩ with eccentric wheels (B). Put the eccentric wheels (B) into the corresponding holes on part ⑩ and use a screwdriver to turn it clockwise to tighten, the installation position is as shown.

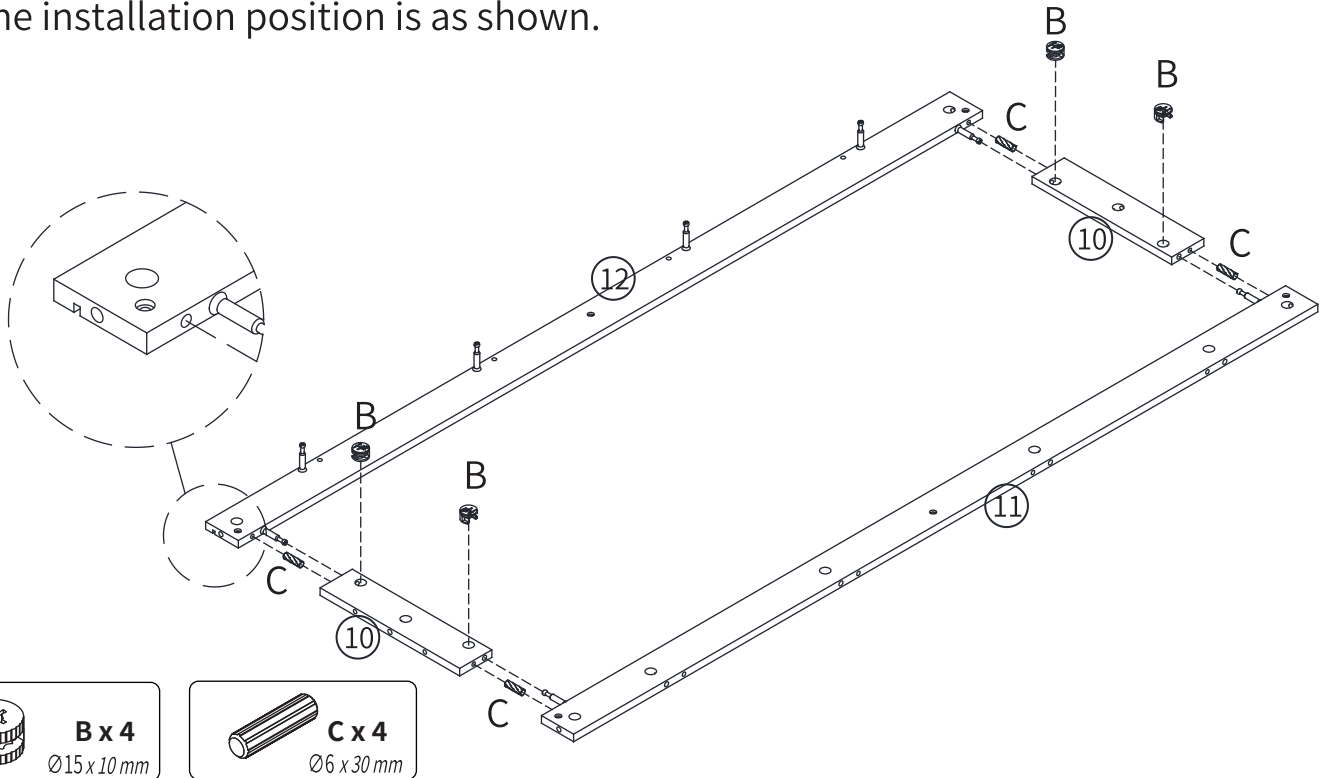

## Step 15

Insert wooden dowel (C) on part ⑫, connect part ⑨ to part ⑫ with eccentric wheels (B). Put the eccentric wheels (B) into the corresponding holes on part ⑨ and use a screwdriver to turn it clockwise to tighten, the installation position is as shown.

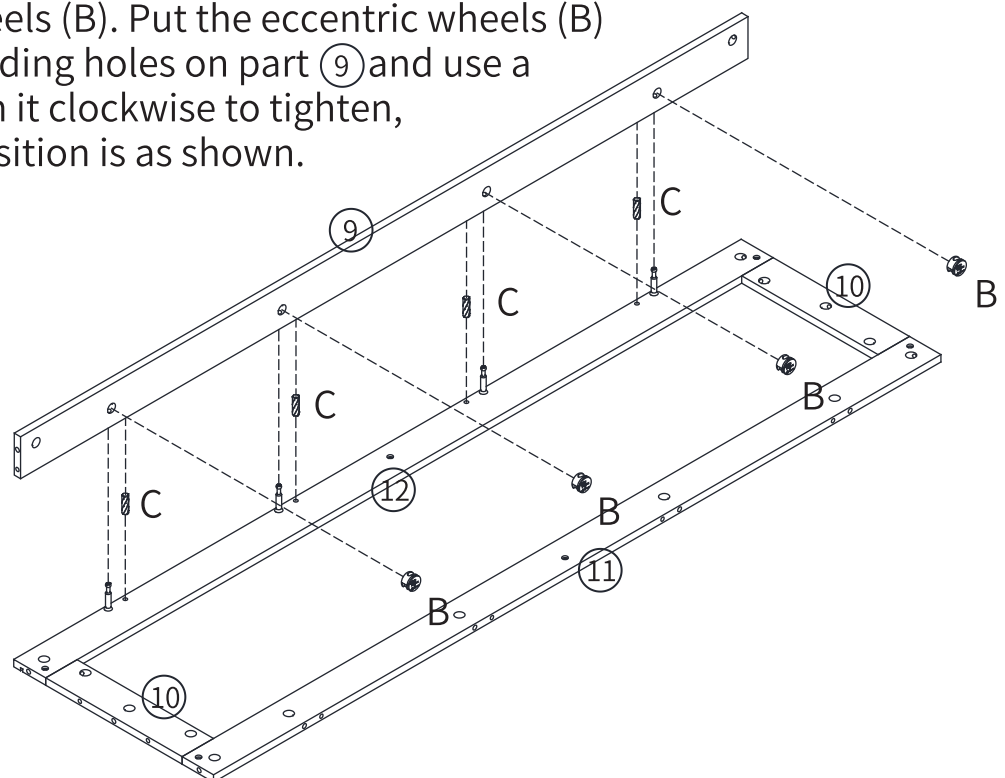

**Step 16** Insert wooden dowel (C) on part ⑦⑧, connect part ⑦⑧ to part ⑨⑩⑪⑫ with eccentric wheels (B). Put the eccentric wheels (B) into the corresponding holes on part ⑨⑩⑪⑫ and use a screwdriver to turn it clockwise to tighten, the installation position is as shown.

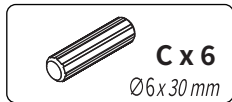
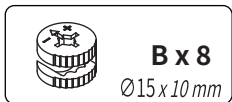
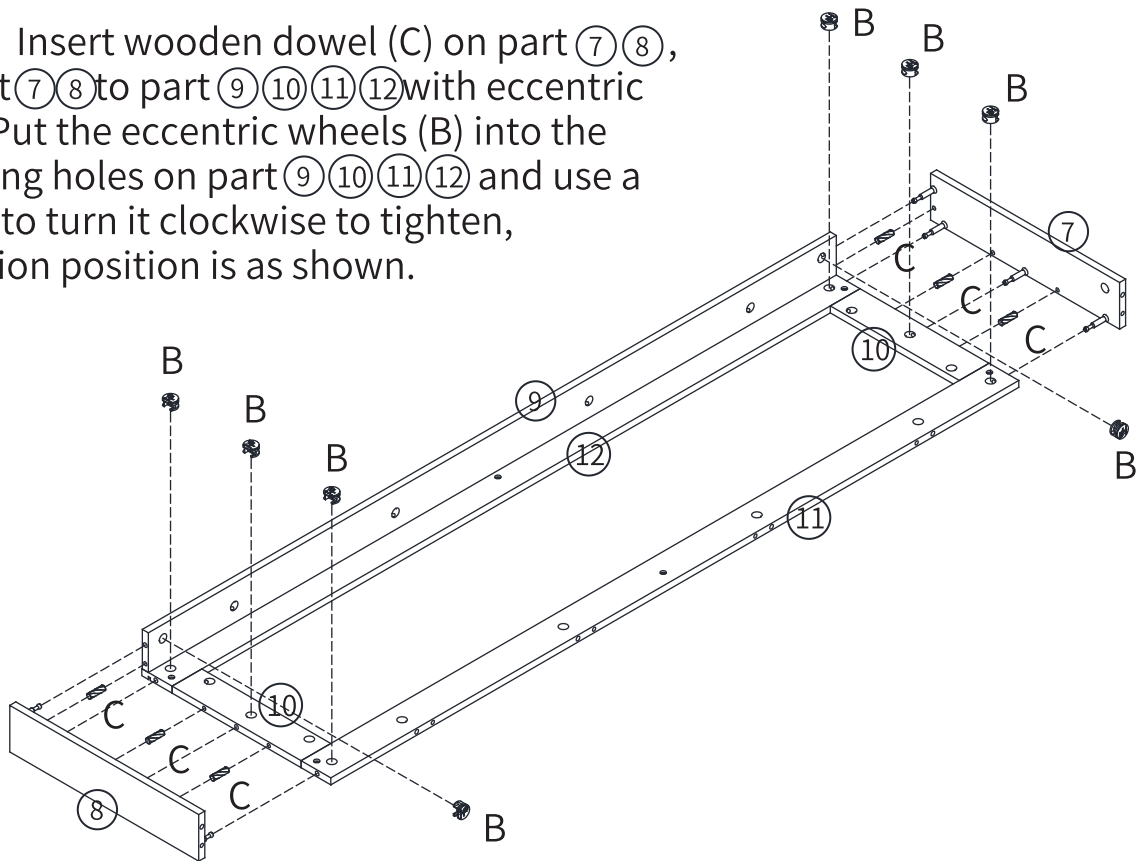

**Step 17** Insert wooden dowel (C) on part ⑥, connect part ⑥ to part ⑦⑧⑪ with eccentric wheels (B). Put the eccentric wheels (B) into the corresponding holes on part ⑦⑧⑪ and use a screwdriver to turn it clockwise to tighten, the installation position is as shown.

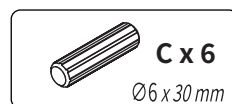
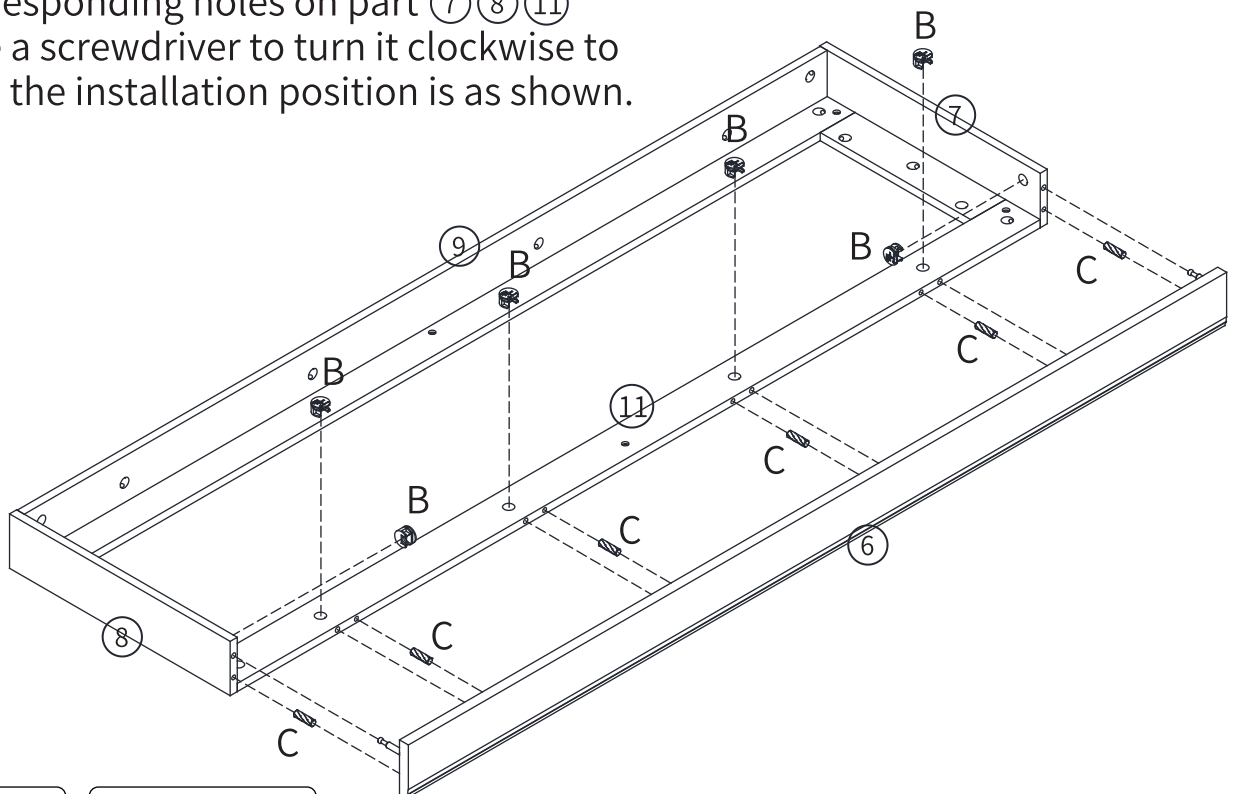

## Step 18

Turn the cabinet upside down and put ⑱ and ⑳ in alternately

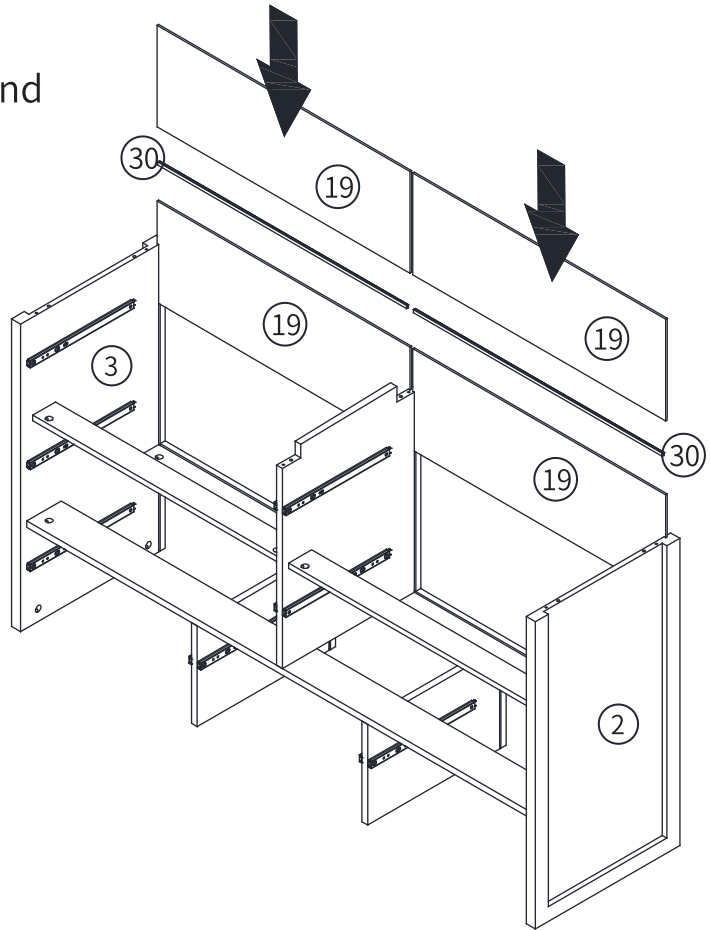

## Step 19

Insert wooden dowel (C) on part ⑲ ③ ⑳, connect part ⑥ ⑦ ⑧ ⑨ to part ⑲ ③ ⑳ with screw (D)

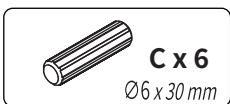
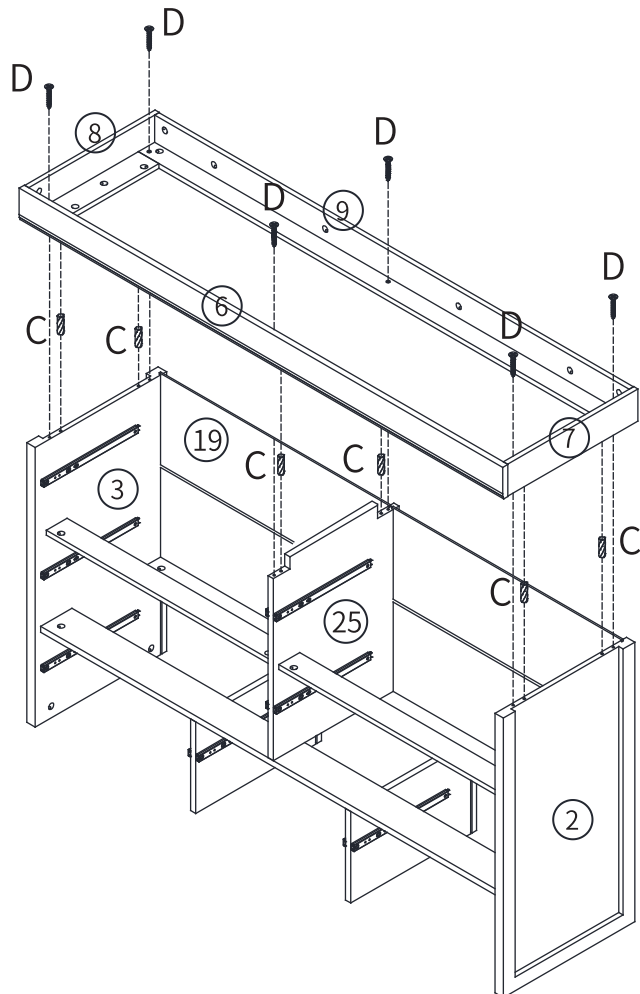

## Step 20

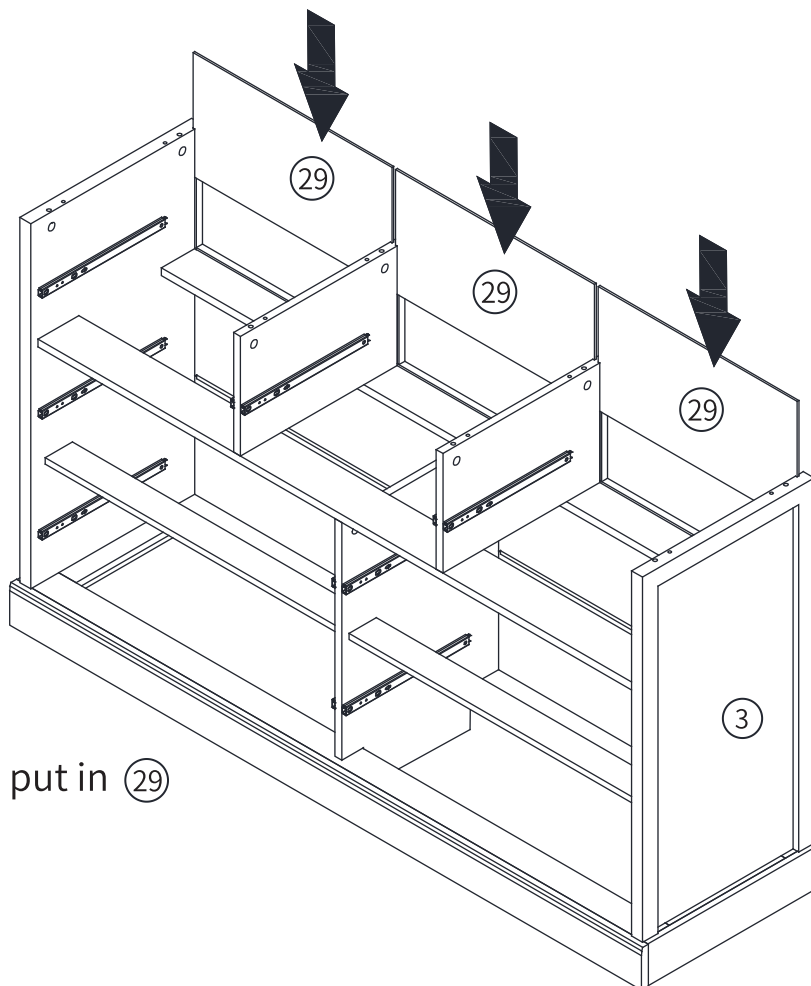

Turn the cabinet over and put in 29

## Step 21

Insert wooden dowel (C) on part 2 3 4, connect part 1 to part 2 3 4 with eccentric wheels (B). Put the eccentric wheels (B) into the corresponding holes on part 2 3 4 and use a screwdriver to turn it clockwise to tighten, the installation position is as shown.

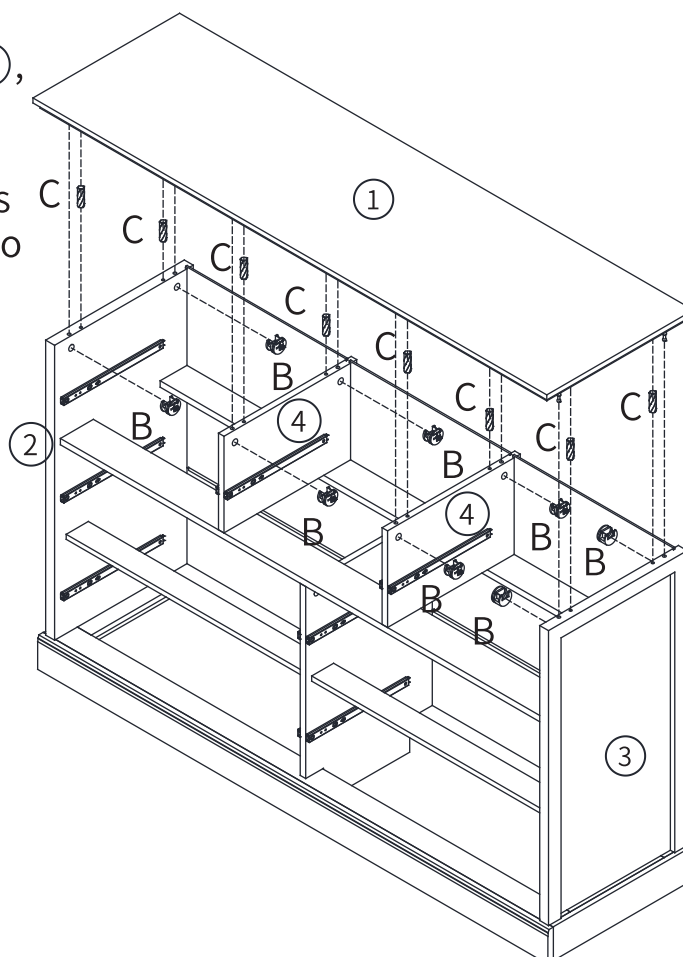

## Step 22

Use (K) and (I) to nail the back to reinforce the cabinet

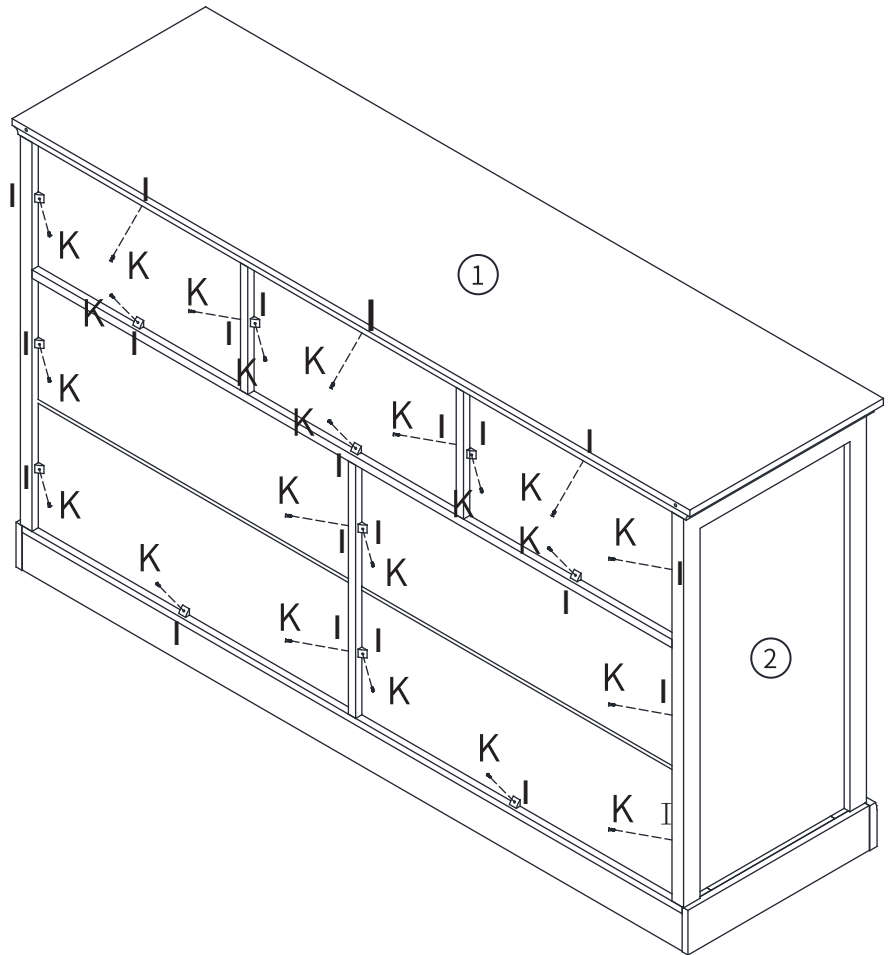
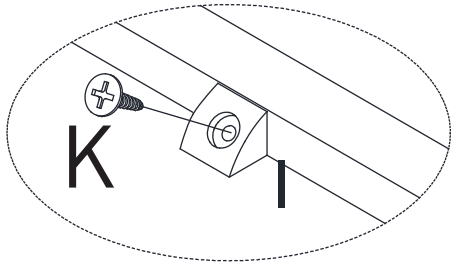

**I x 22**  
15 x 13 x 10 mm

**K x 22**  
M3 x 16 mm

## Step 23

x 3

Connect ⑮ ⑯ ⑳ with (D)  
Repeat this step three times

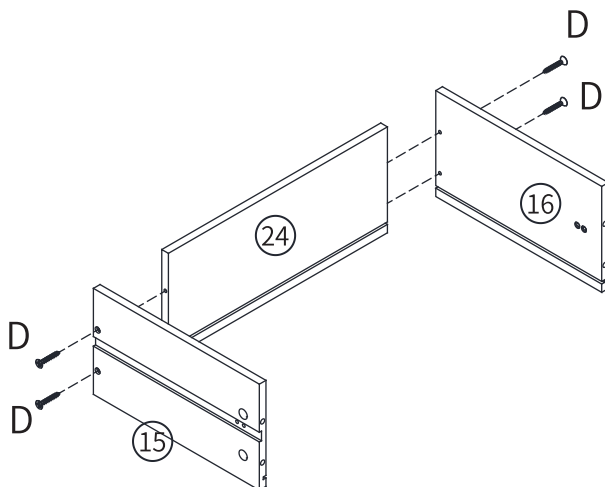

**D x 12**  
Ø8 x M4 x 35 mm

## Step 24

x 3

Push ㉔ downward  
Repeat this step three times

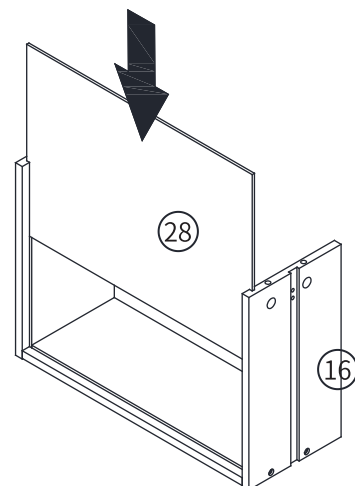

## Step 25

Screw the screw (A) into ②1 ②2 and ②3, use screw(G) connects to handle(F) through the middle hole

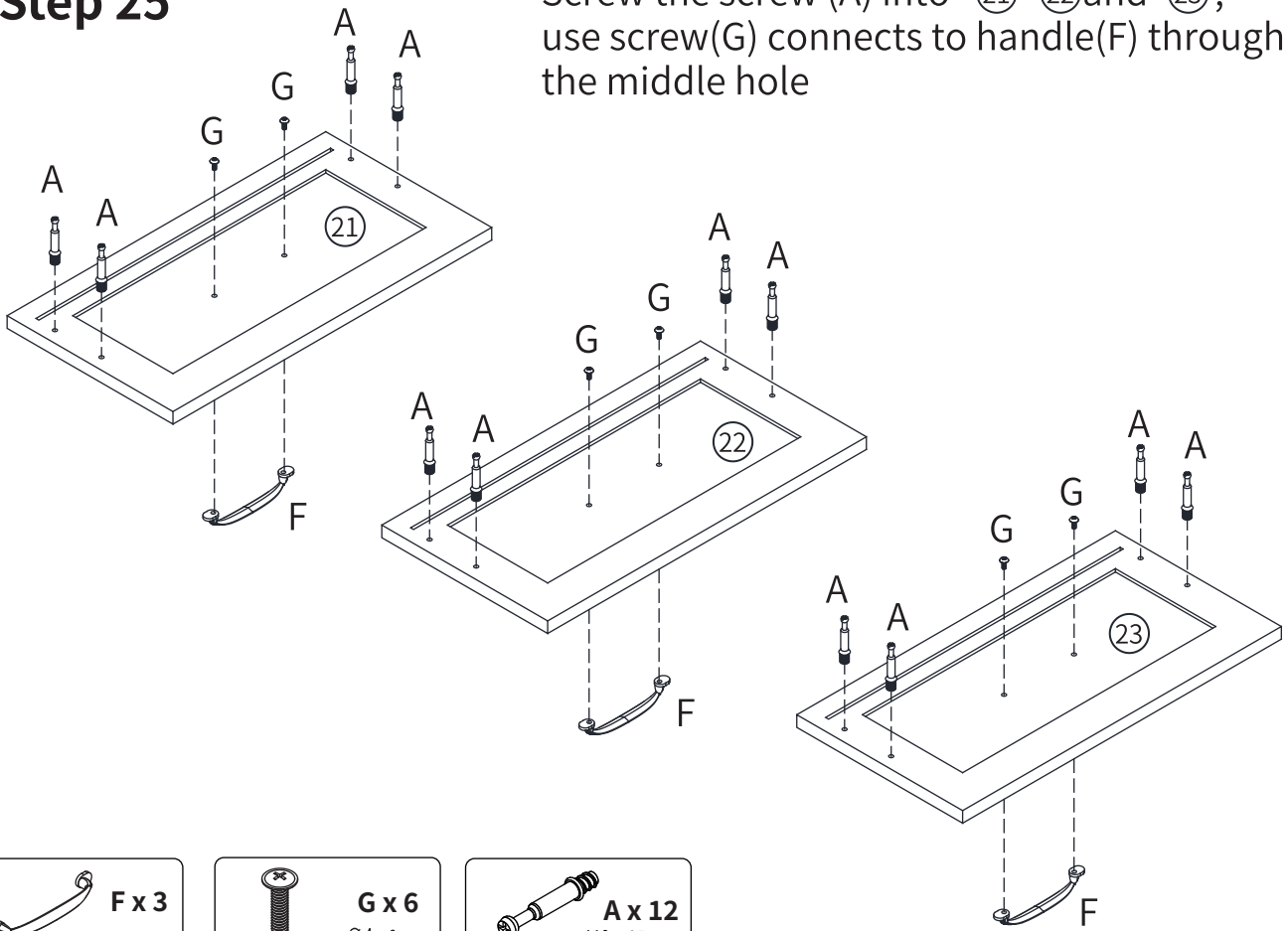

## Step 26

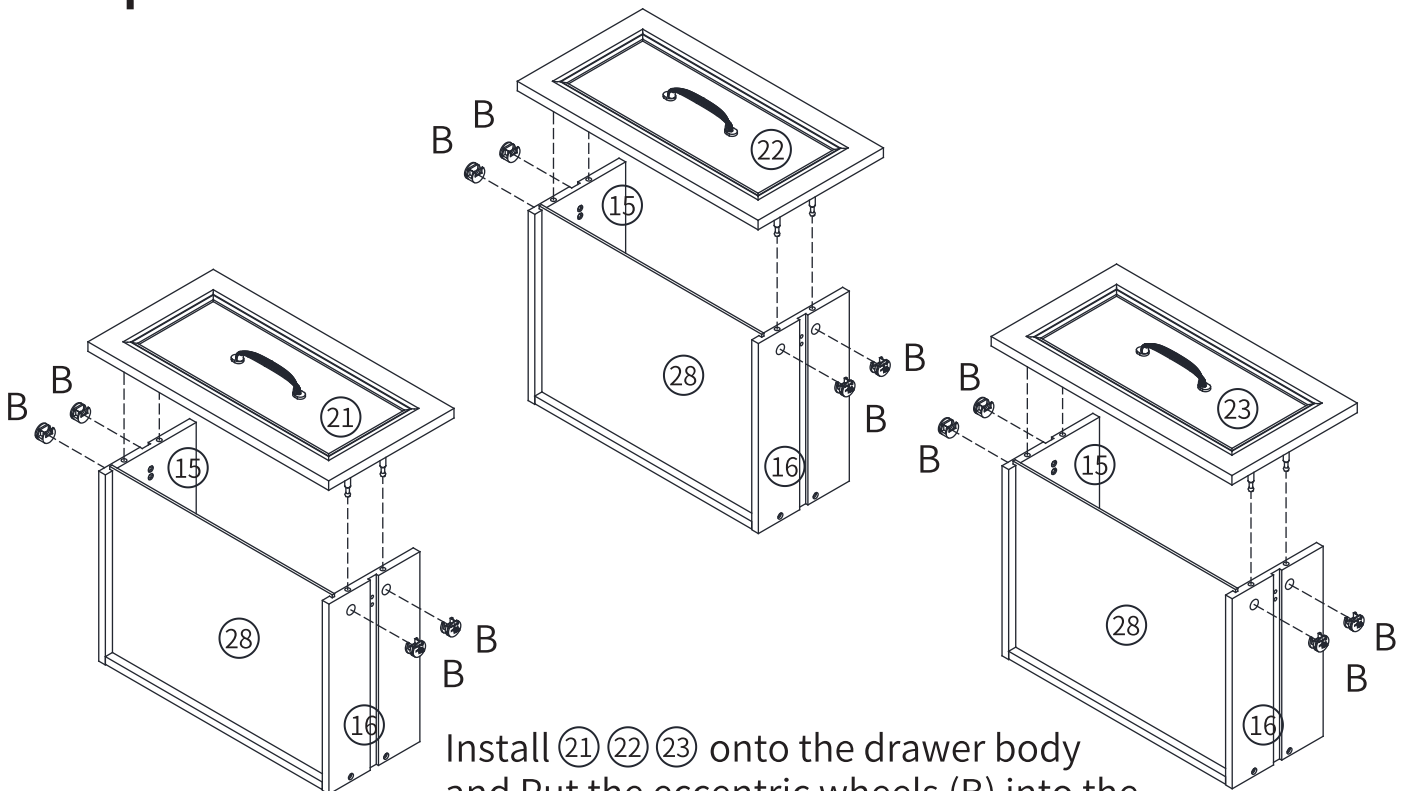

Install ②1 ②2 ②3 onto the drawer body and Put the eccentric wheels (B) into the corresponding holes on part ①5 ①6 and use a screwdriver to turn it clockwise to tighten, the installation position is as shown.



## Step 27

# x 4

Connect (15) (16) (17) (18) with (D)  
Repeat this step four times

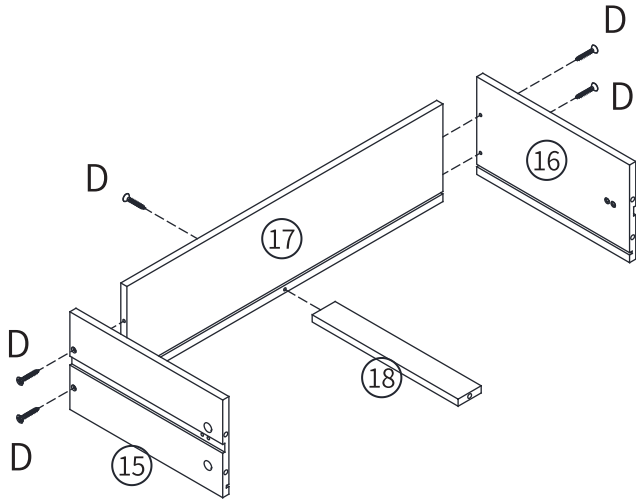

## Step 28

# x 4

Push (20) downward  
Repeat this step four times

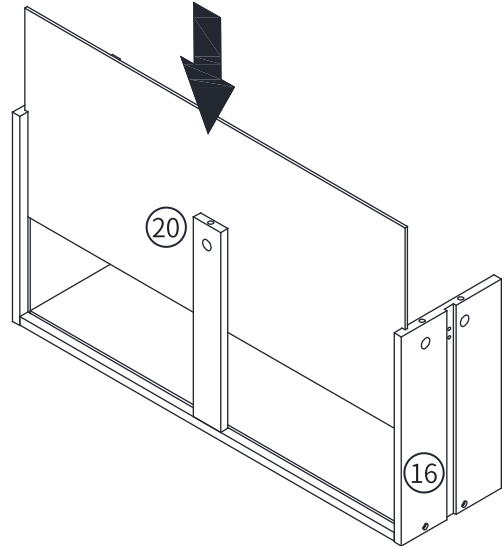

## Step 29

Screw the screw (A) into (13) and (14), use screw (G) connects to handle (F) through the middle hole, There are both 2 sets part (13) (14)

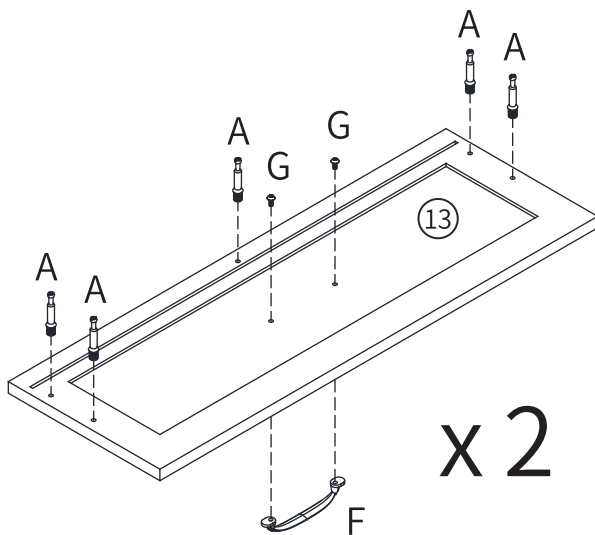

# x 2

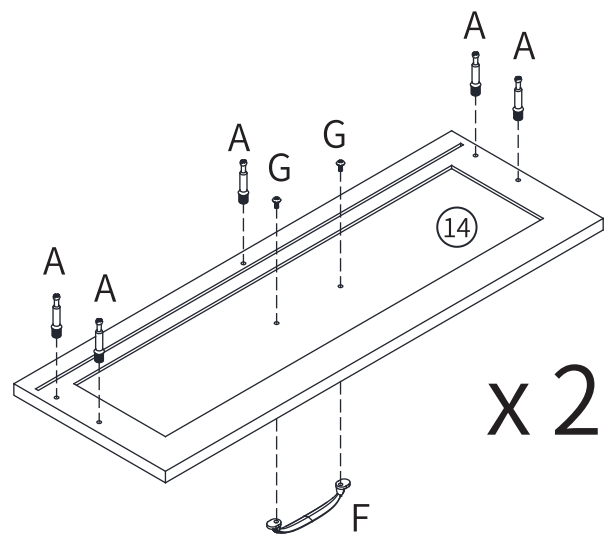

# x 2



## Step 30

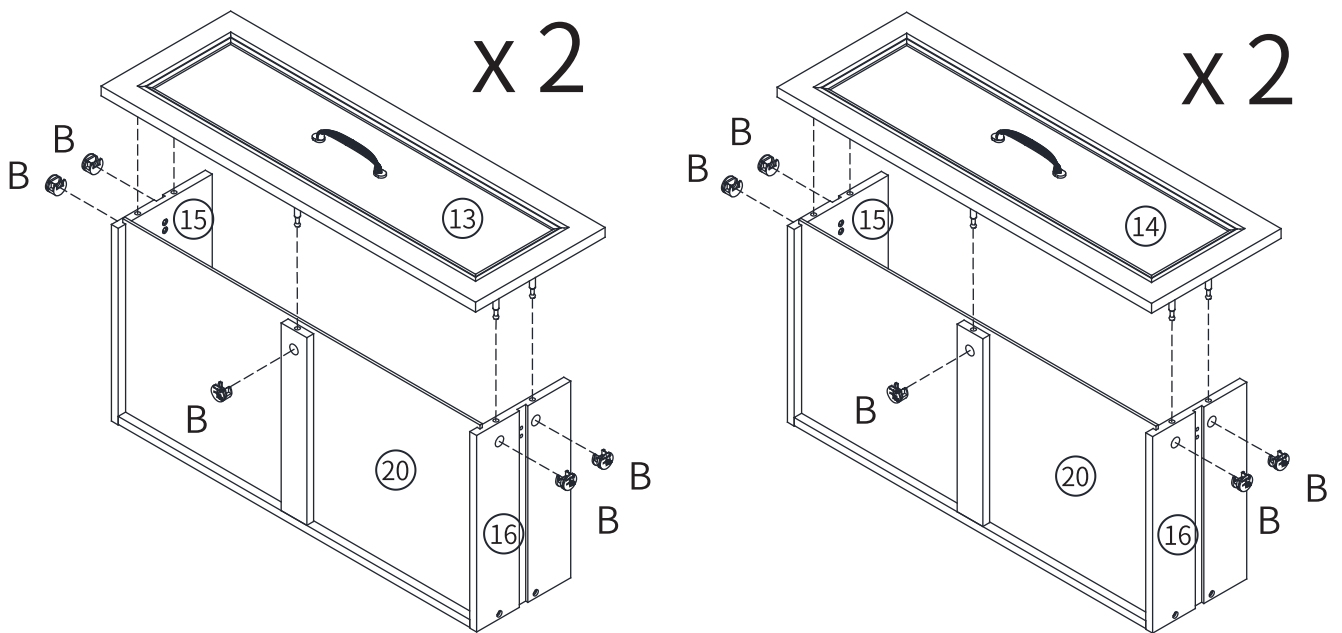

Install ⑬ ⑭ onto the drawer body and Put the eccentric wheels (B) into the corresponding holes on part ⑮ ⑯ and use a screwdriver to turn it clockwise to tighten, the installation position is as shown. There are both 2 sets part ⑬ ⑭



B x 20  
Ø15 x 10 mm

## Step 31

slide the slide rail in the direction of the arrow to the farthest position after confirming that the sliding rails on both sides are close to the slot at the same time, push the drawer inward

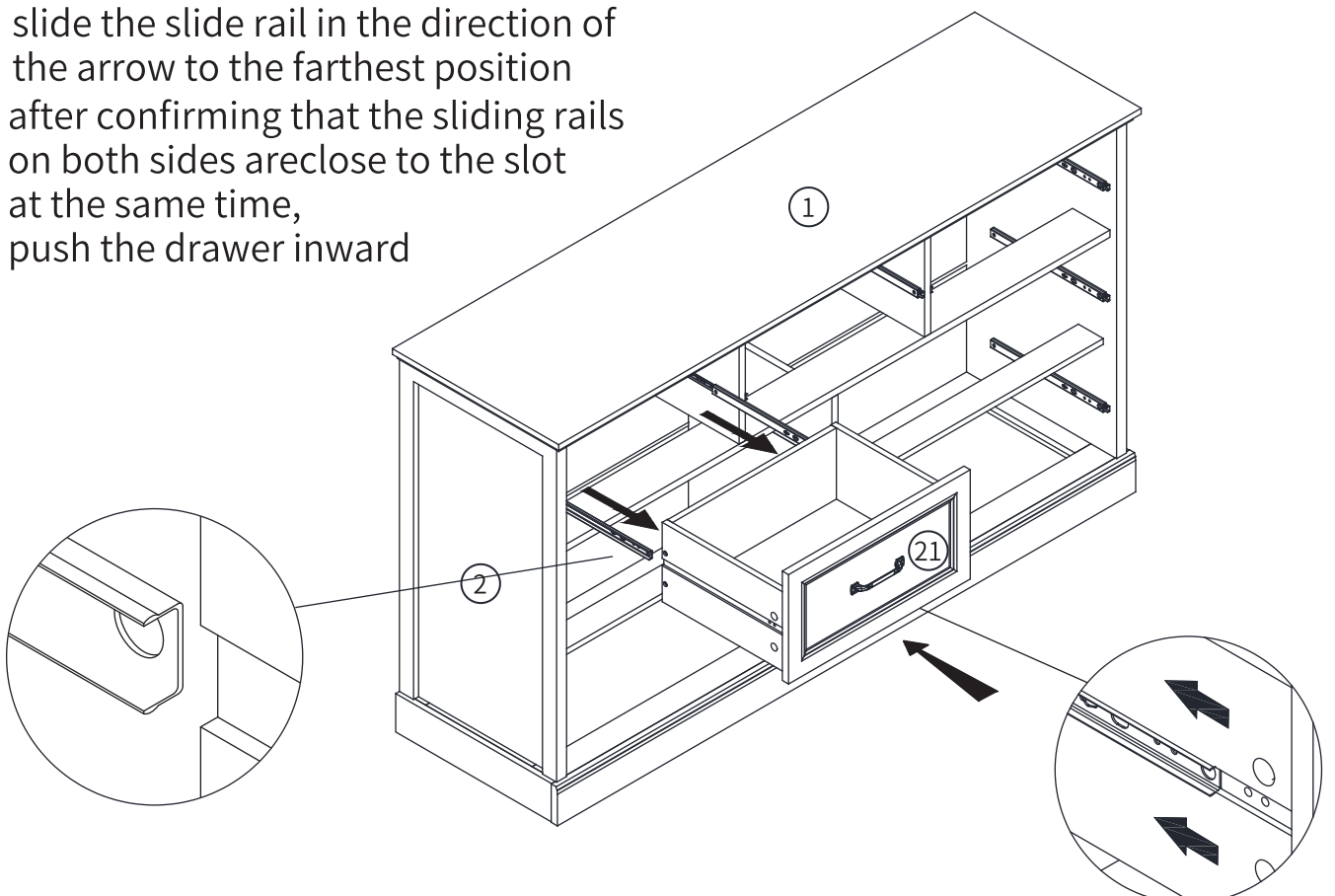

## Step 32

the screw (G) can be locked after aligning the rear panel hole and the sliding rail hole through fine-tuning

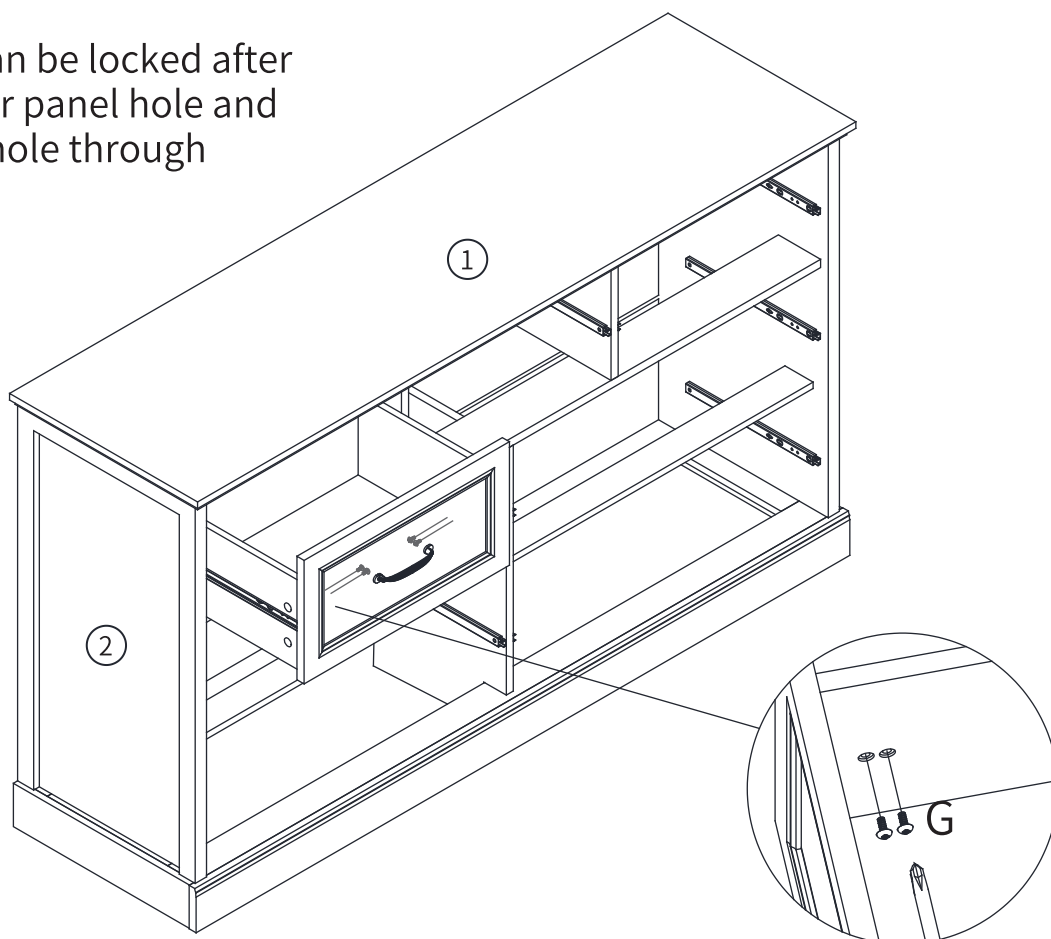

## Step 33

Install drawers ⑬ ⑭ ⑰ ⑱ ㉓ to the designated positions according to the above method.

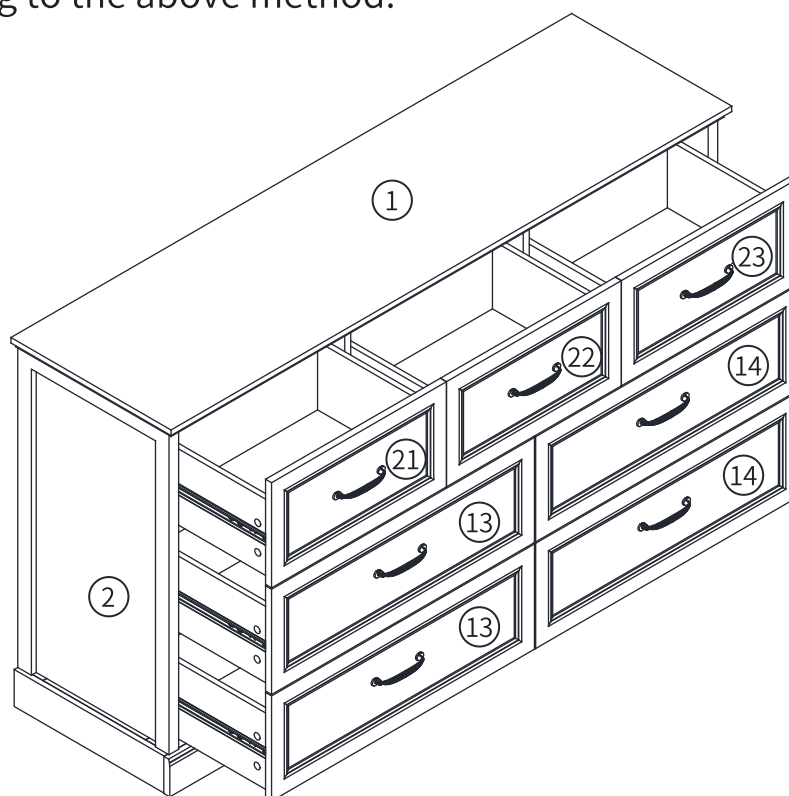

## Step 34

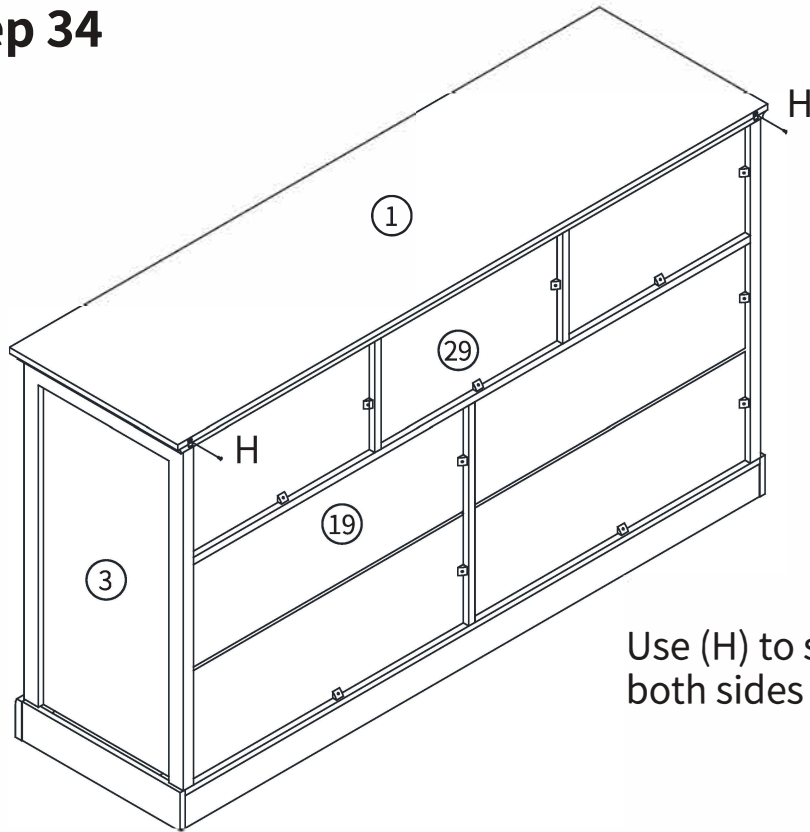

Use (H) to screw one end of (H) onto both sides of the back of ①.

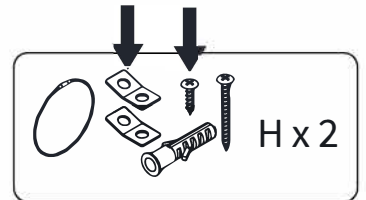

## Step 35

Pass the ring (H) through the two iron plates (H)

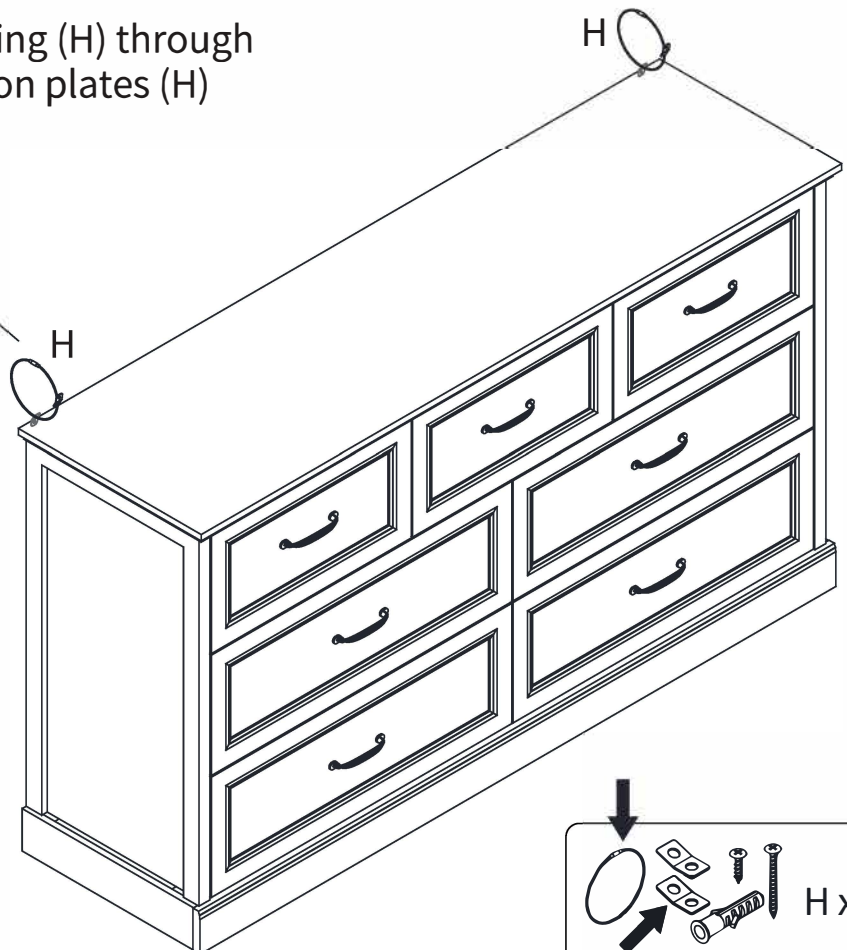

### Step 36

Make a hole in the wall. Bury (H) into the hole. Use (H) to nail one of the iron pieces into the wall.

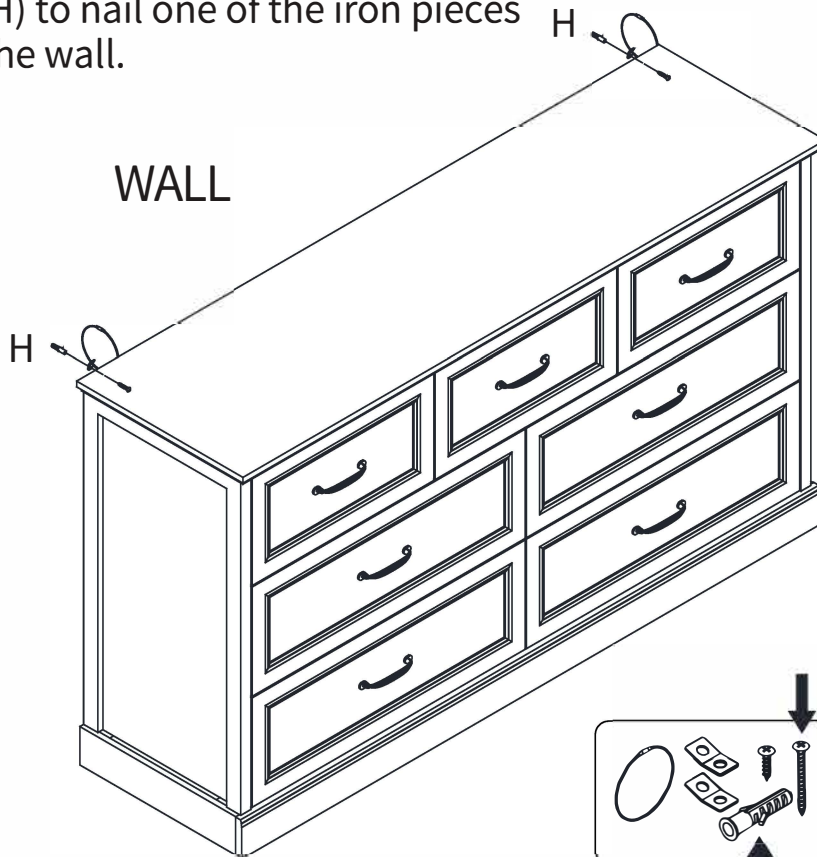
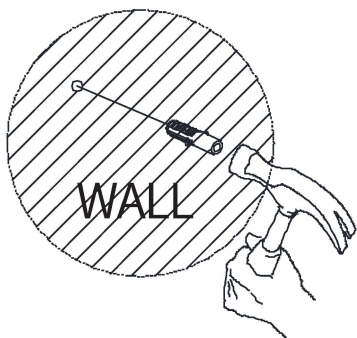
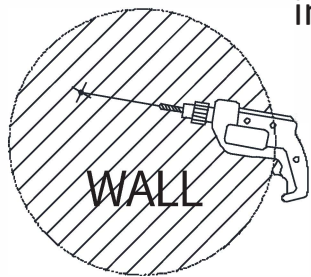

### Step 37

