

ASSEMBLY INSTRUCTIONS

TV CABINET

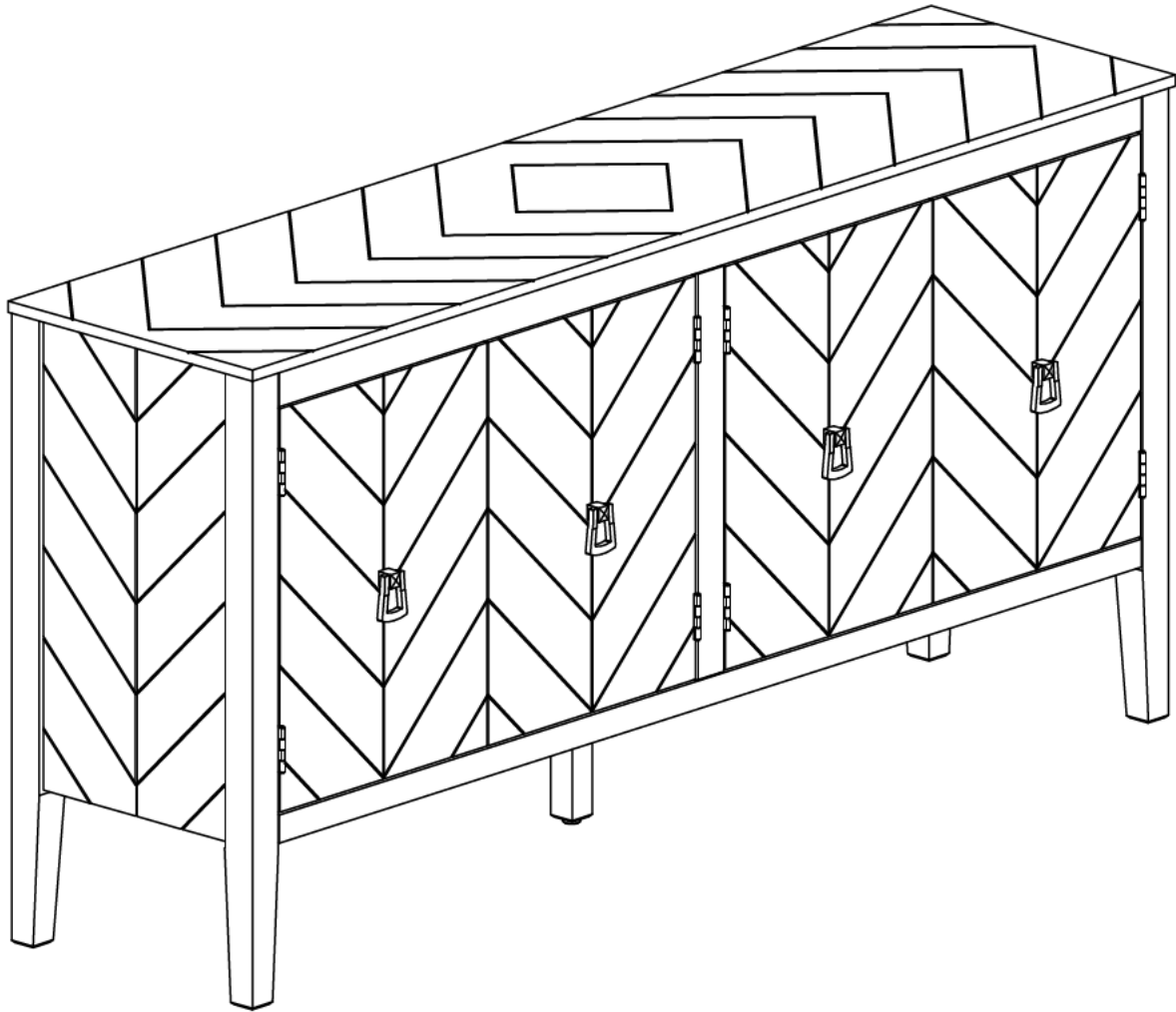

Thank you for purchasing this quality product. Be sure to check all packing material carefully for small parts which may have come loose inside the carton during shipment. Separate, identify and count all parts and hardware.

Compare with the parts list to be sure all parts are present.

"DO NOT TIGHTEN SCREWS UNTIL COMPLETELY ASSEMBLED"

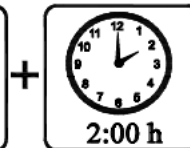
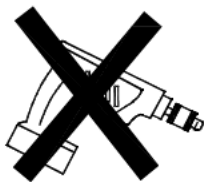

* Use of power tool to assemble this product will invalidate any claim and damage this product making unsafe !!!
* Please assemble on a clean soft surface to avoid damage.

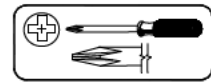

Tools Required

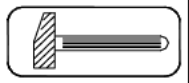

(Not included)



(Not included)

IMPORTANT:

PLEASE READ INSTRUCTION BEFORE STARTING THE ASSEMBLY

PLEASE DO NOT RETURN TO STORE



**Please do not return this product to the retailer!!
We are able to assist you in ANY way**

If you find that you have any trouble with assembly or missing or damaged parts please contact the seller.

Before Installation

Important – Please read these instructions fully before starting assembly

Thank you for purchasing this quality product. Be sure to check all packing materials carefully for small parts, which may have come loose inside the carton during shipment. Identify and count all items according to the PARTS LIST and/or HARDWARE LIST shown below. Check you have all the components and tools listed on the following pages.

- We recommend that you assemble this product with the assistance of another person; this will make the assembly easier, and will help eliminate damage to the product or injury to persons during assembly.
- Please do not over tighten screws or bolts until the assembly is completed.
- Keep children and animal away from the work area, small parts could choke if swallowed.
- Please put all parts on a non-abrasive floor before assembly, and follow the assembly steps to assemble your newly purchased product correctly and efficiently.

Cam Lock Assembly Instructions

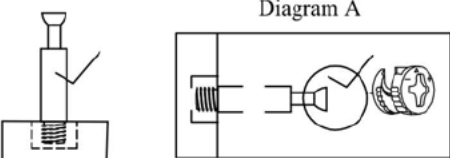
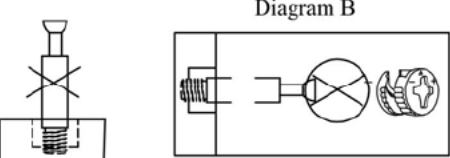
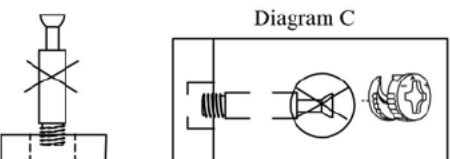
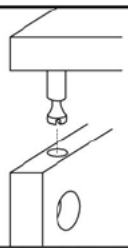
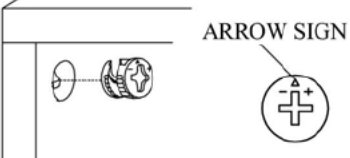
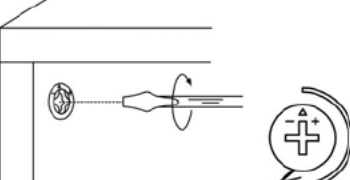

| | | |
|---|-------------------|---|
|  | <p>Diagram A</p> | <p>Insert Cam Bolt into hole as shown in diagram A.</p> |
|  | <p>Diagram B</p> | <p>Make sure not to insert the Cam Bolt: Too deep as shown in figure B as this will cause the Cam Lock to be misaligned and unable to interlock properly.</p> |
|  | <p>Diagram C</p> | <p>Also avoid inserting the Cam Bolt too close to the surface of the hole as shown in figure C, as this will cause the Cam Lock to be too loose, and not interlock properly.</p> |
|  | | <p>Connect the panels together.</p> |
|  | <p>ARROW SIGN</p> | <p>Insert the Cam Lock so the side opening fits over the head of the Cam Bolt.</p> |
|  | | <p>To tighten the Cam Lock, turn it clockwise on half a turn with a flat screwdriver. <i>*Do not use an automatic screwdriver as it may bend or break if too much power is imposed.</i></p> |

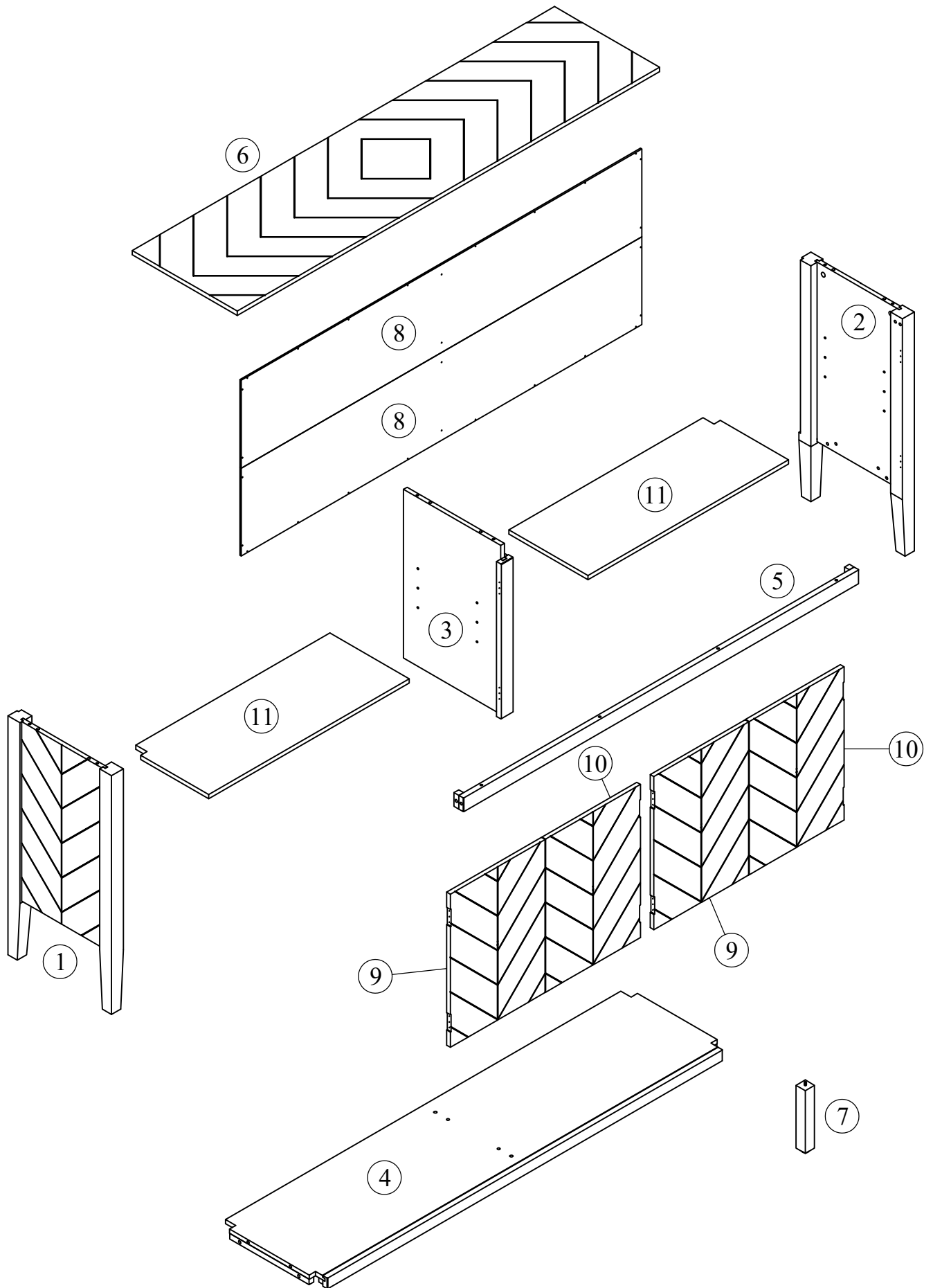
Detail View - CABINET





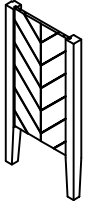
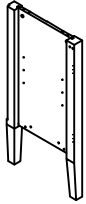
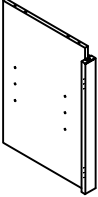
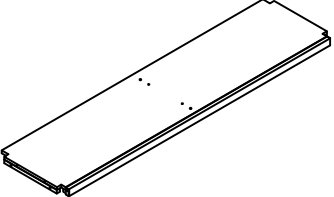
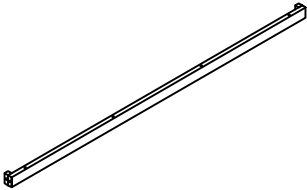
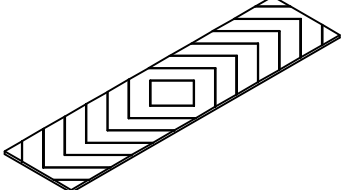

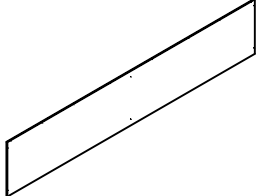
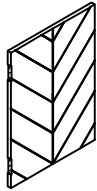
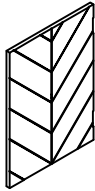
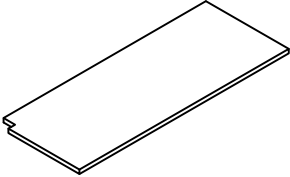



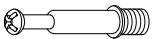

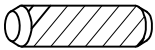
Identifying the Hardware -Identify the hardware using the illustrations below.

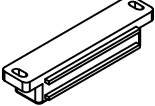
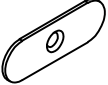
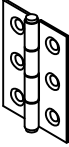
Part List

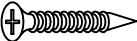
| | |
|--|--|
| <p>1</p>  <p>Side Panel (L) - 1pc</p> | <p>2</p>  <p>Side Panel (R) - 1pc</p> |
| <p>3</p>  <p>Mid Panel - 1pc</p> | <p>4</p>  <p>Bottom Frame - 1pc</p> |
| <p>5</p>  <p>Top Crossbar Front - 1pc</p> | <p>6</p>  <p>Top Panel - 1pc</p> |
| <p>7</p>  <p>Mid Cabinet Feet - 1pc</p> | <p>8</p>  <p>Back Panel - 2pcs</p> |
| <p>9</p>  <p>Door Cabinet (L) - 2pcs</p> | <p>10</p>  <p>Door Cabinet (R) - 2pcs</p> |
| <p>11</p>  <p>Adjustable Shelf - 2pcs</p> | |

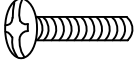
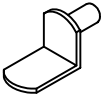
Hardware List

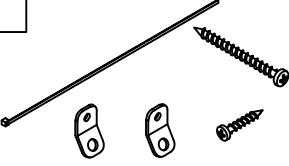
| | | |
|--|---|---|
| <p>A</p>  <p>ø6x35mm</p> | <p>B</p>  <p>ø14.5x12mm</p> | <p>C</p>  <p>ø8x30mm</p> |
| <p>Three in one bolts (12pcs) Three in one lock (12pcs) Wood dowel (14pcs)</p> | | |
| <p>D</p>  <p>ø13x1/4"x28mm</p> | <p>E</p>  <p>ø1/4"x16x1mm</p> | <p>F</p>  <p>71x16x14mm</p> |
| <p>Hex-Head bolts (6pcs) Washer (6pcs) Door Magnet (2pcs)</p> | | |
| <p>G</p>  <p>35x12x1mm</p> | <p>H</p>  | <p>I</p>  <p>ø6xø3x12mm</p> |
| <p>Magnetic Iron Sheet (4pcs) Hinges (8pcs) Round head screw (4pcs)</p> | | |
| <p>J</p>  <p>ø7xø3.5x12mm</p> | <p>K</p>  | <p>L</p>  <p>ø5/32"x20mm</p> |
| <p>Flat head screw (52pcs) Handle (4pcs) Handle screw (4pcs)</p> | | |
| <p>M</p>  | <p>N</p>  <p>4mm</p> | <p>O</p>  <p>ø7xø3.5x15mm</p> |
| <p>Laminate pad (8pcs) Allen key (1pc) Round head screw (28pcs)</p> | | |
| <p>P</p>  <p>Anti fall hardware (1set)</p> | | |

STEP: 1

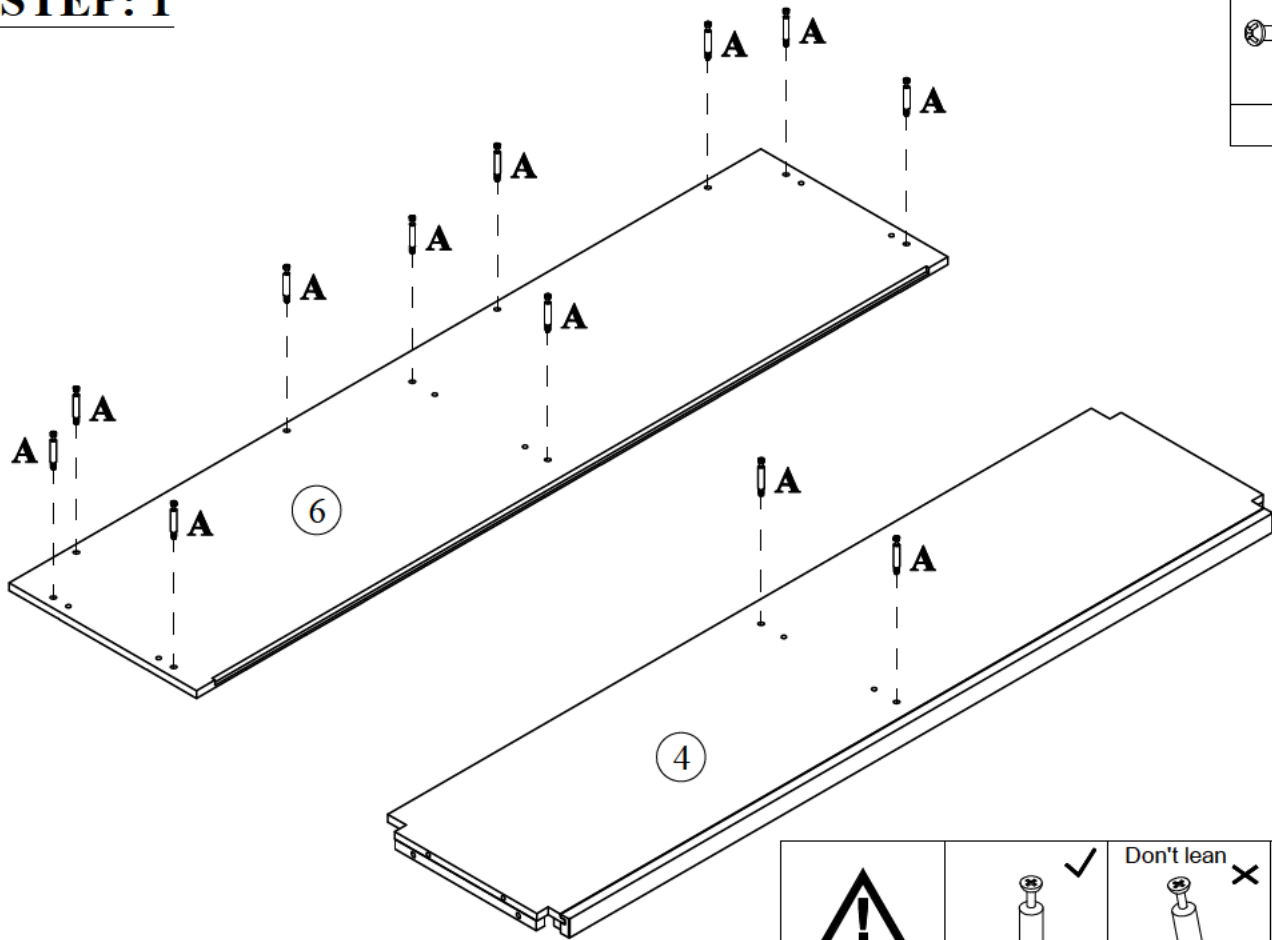

A

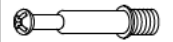

12PCS

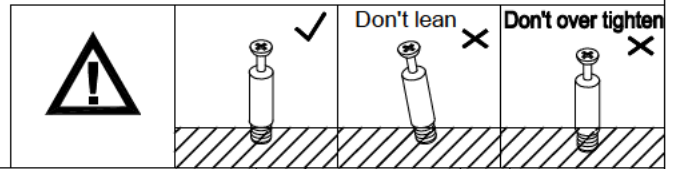

STEP: 2

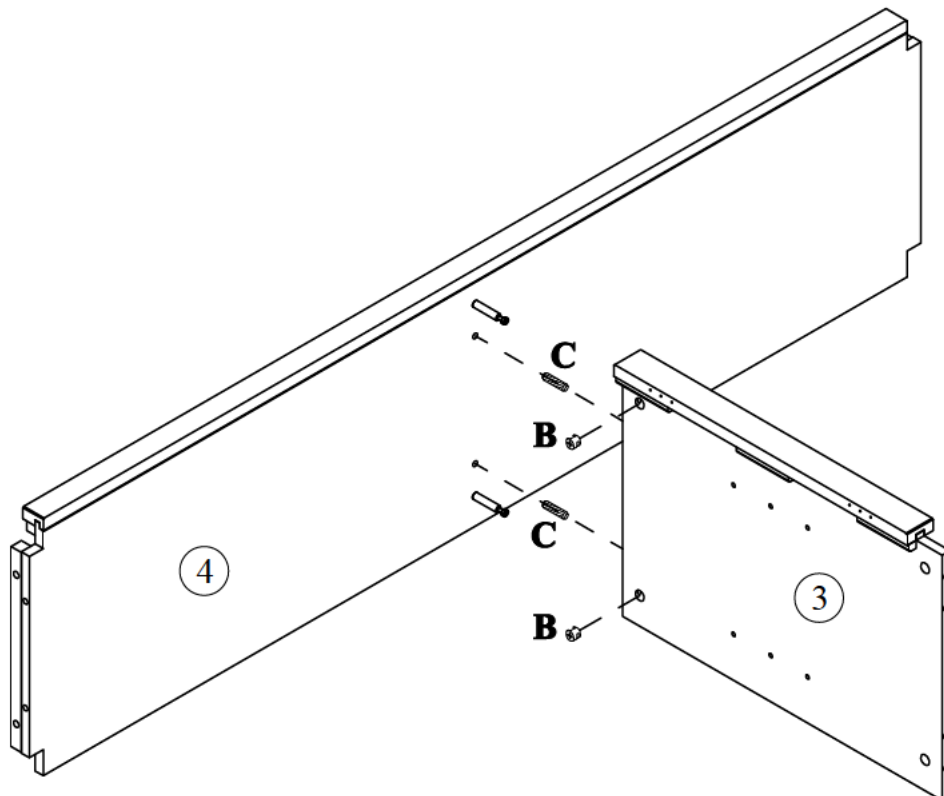

B



2PCS

C

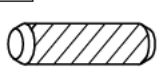

2PCS

STEP: 3

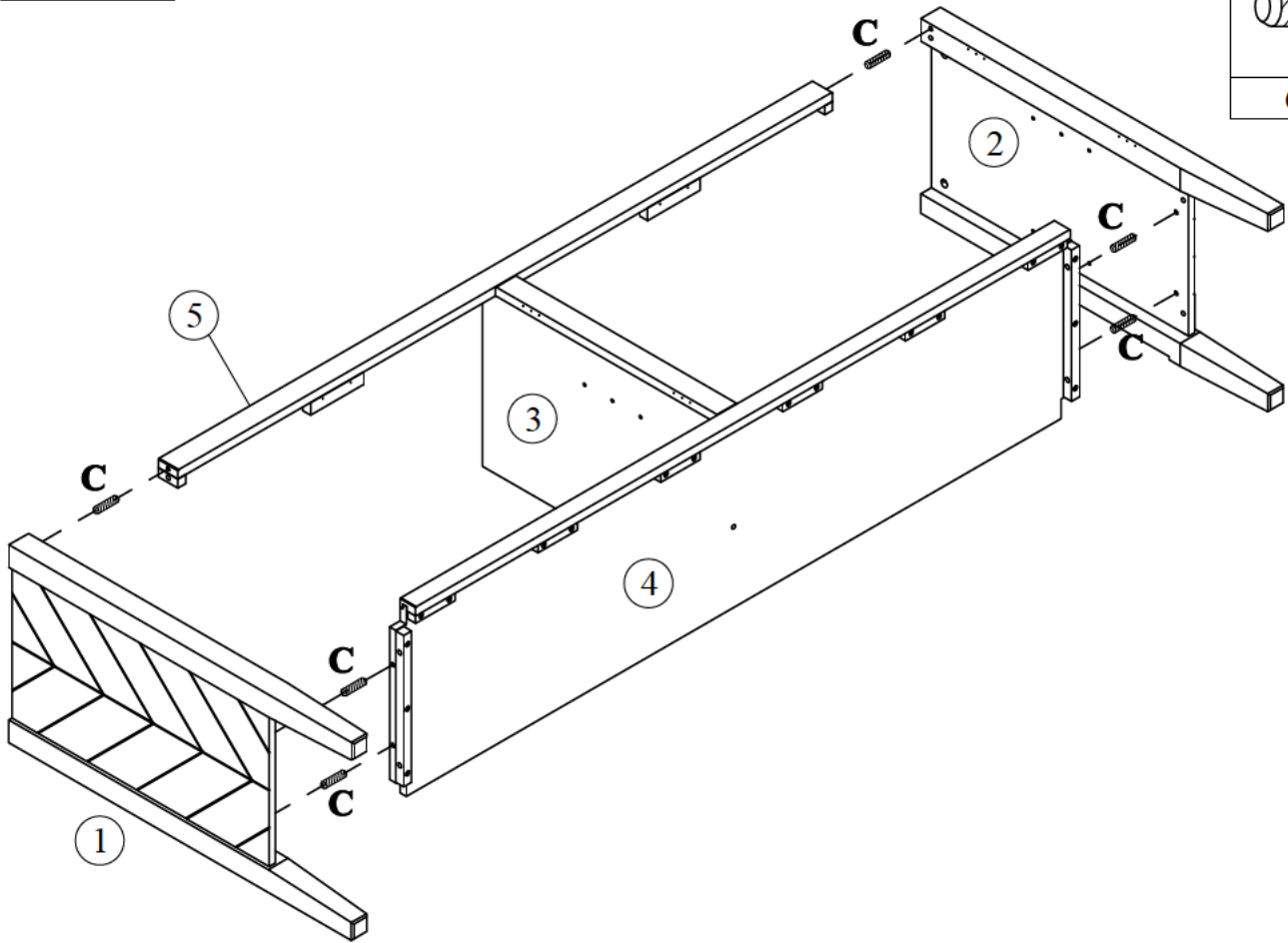

C



6PCS

STEP: 4

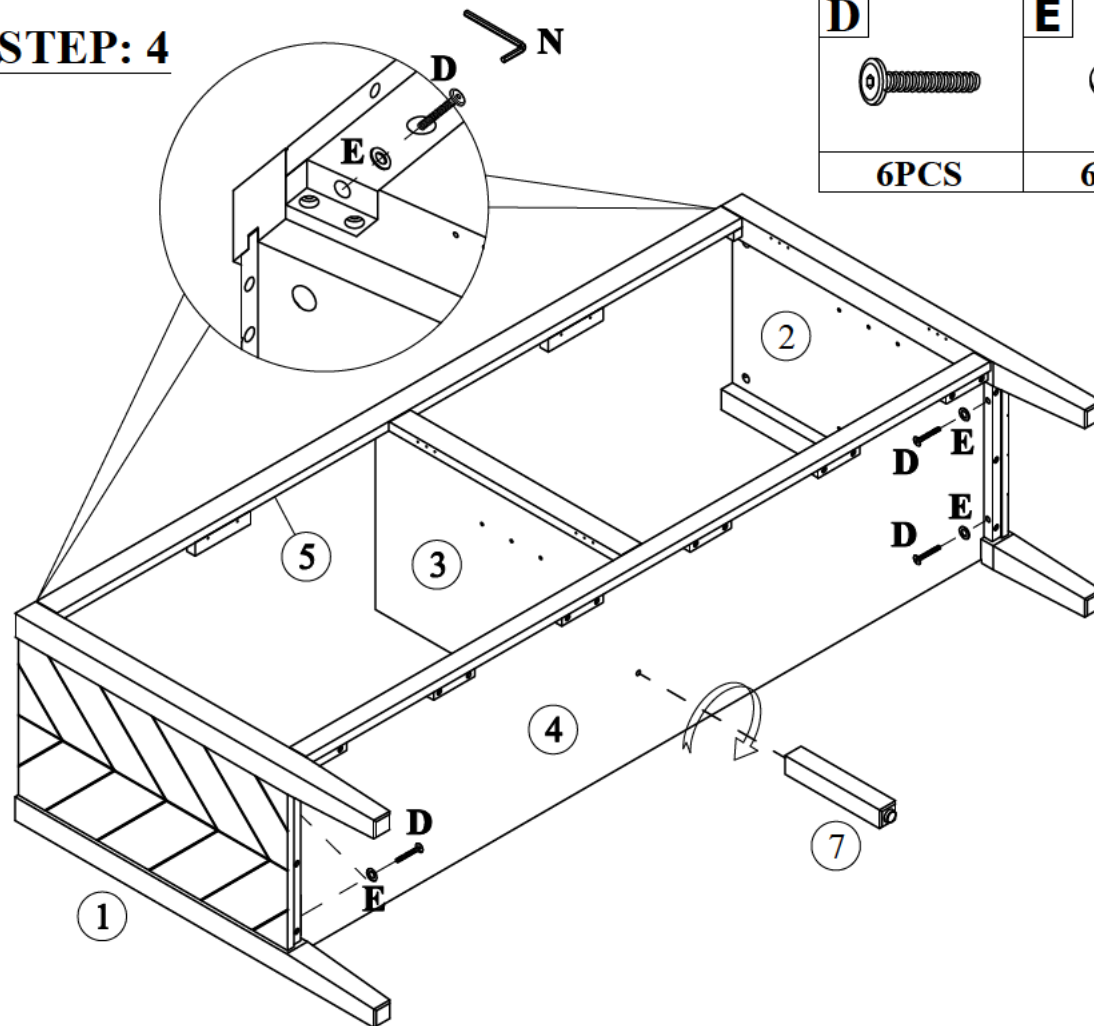

D



6PCS

E



6PCS

N



1PC

STEP: 5

C



6PCS

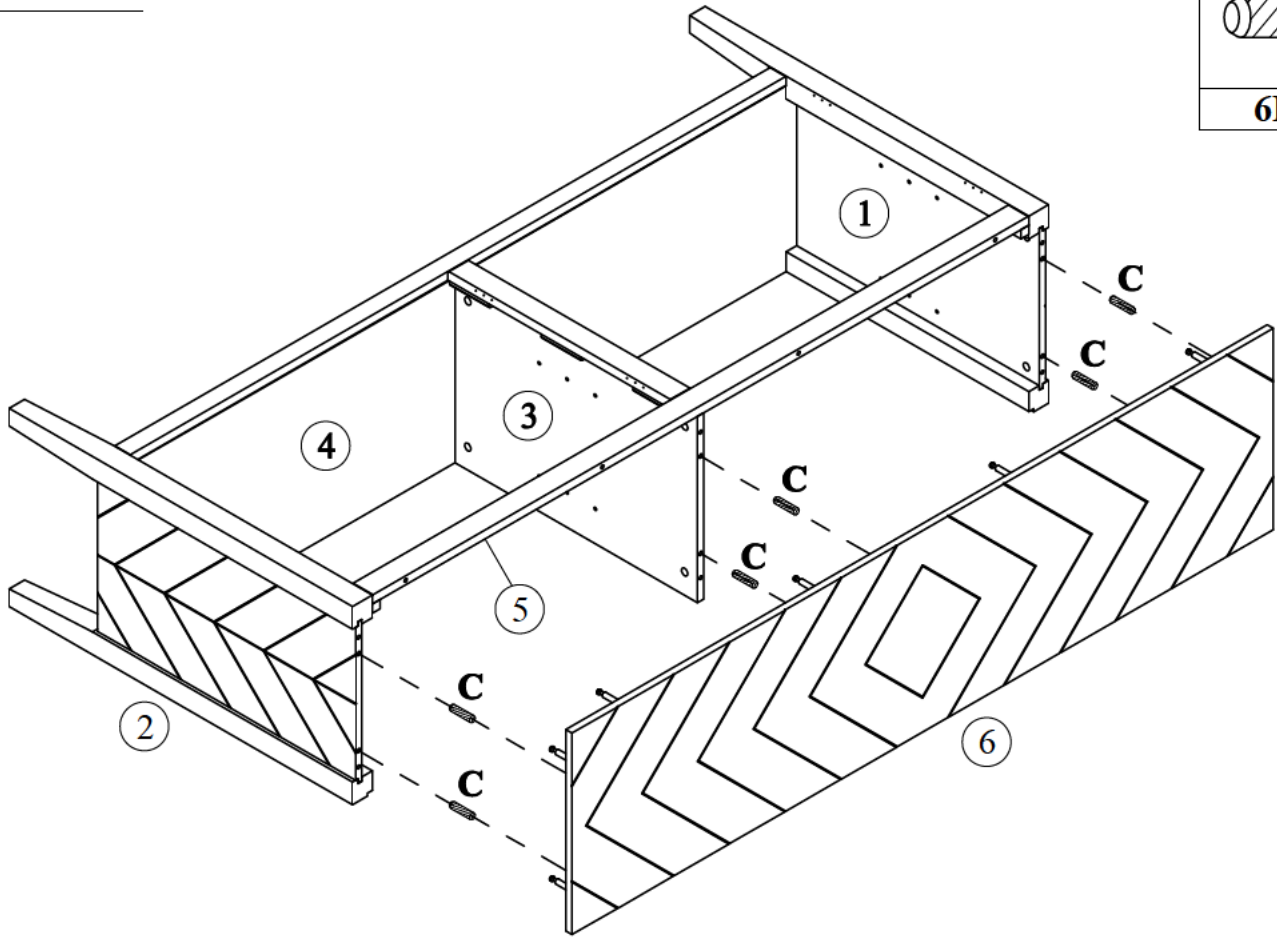

STEP: 6

B



10PCS

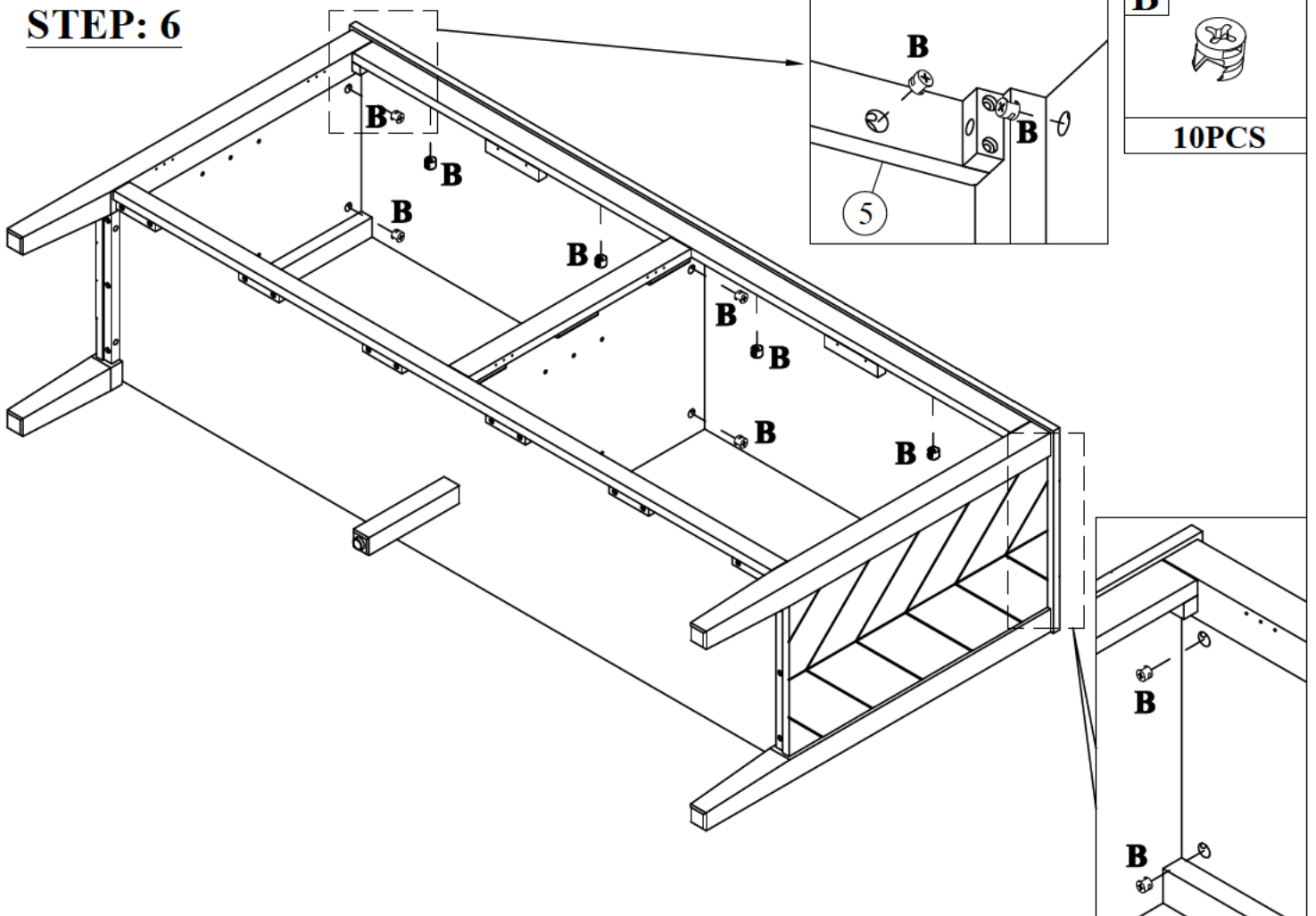

STEP: 7

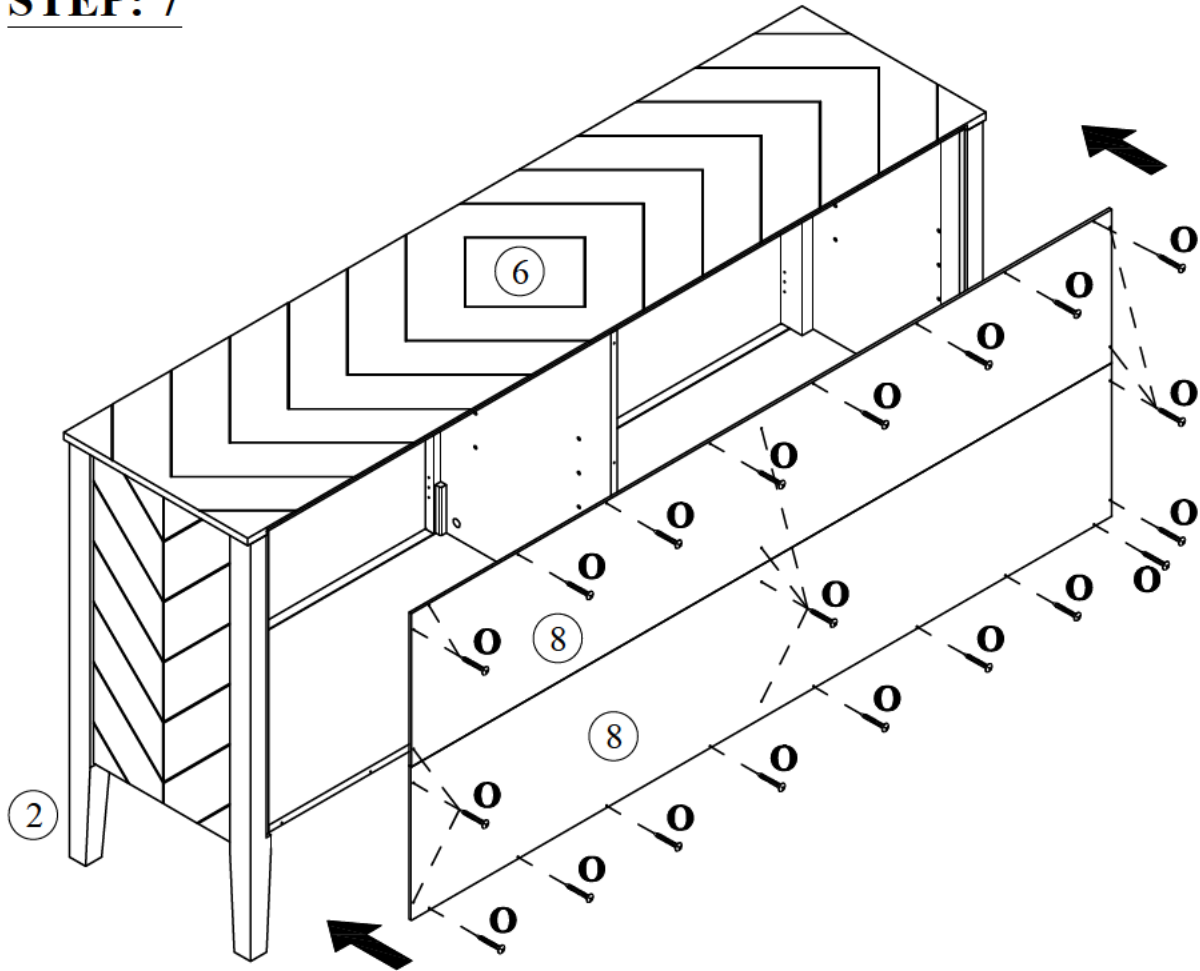

O



28PCS

STEP: 8

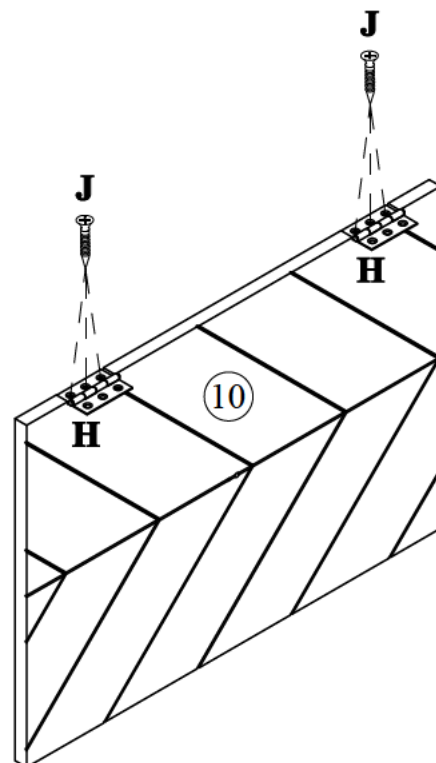
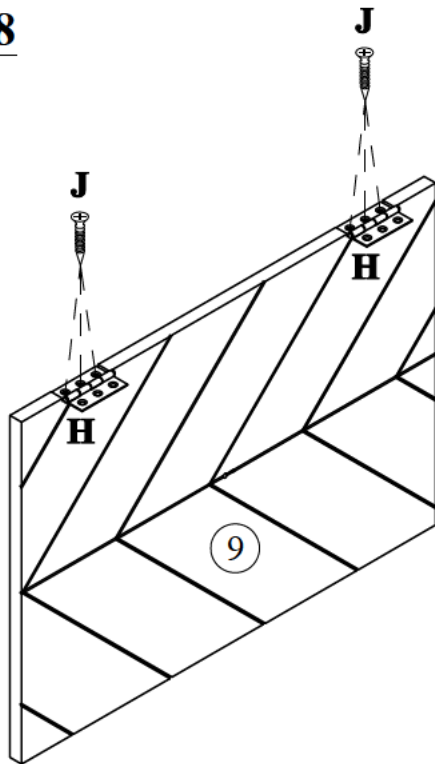

H

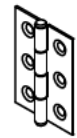

8PCS





J



24PCS

x2

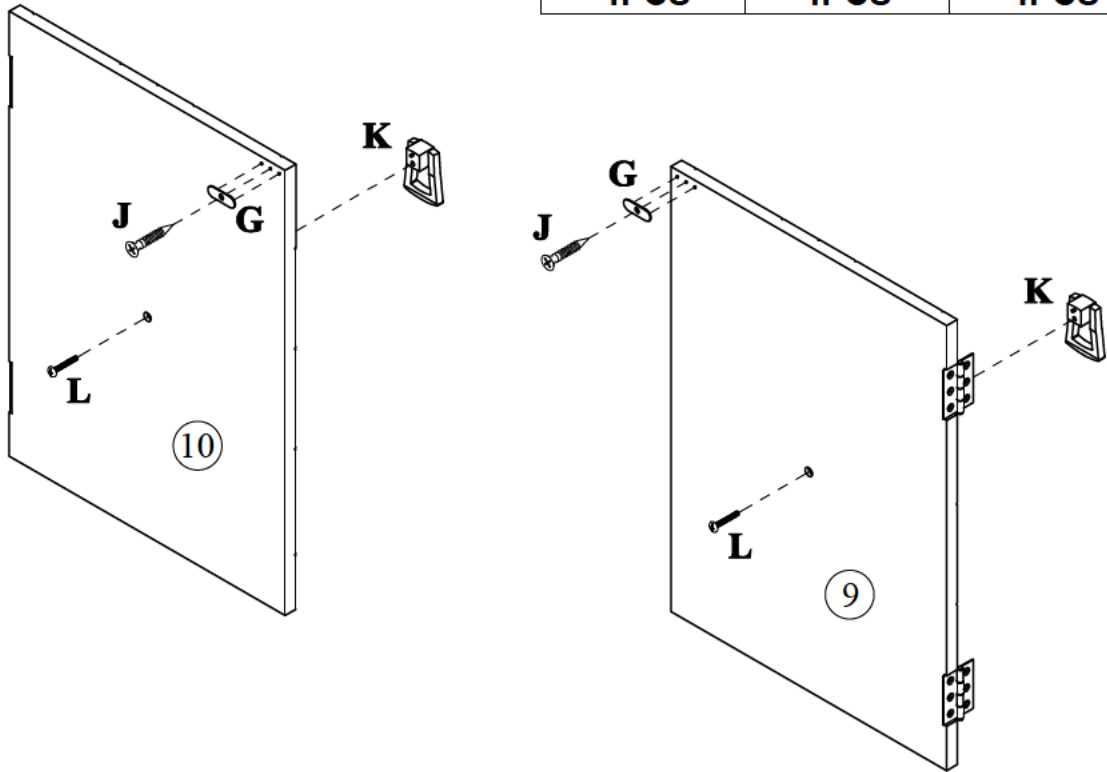

STEP: 9

| | | | |
|---|--|--|---|
| G | J | K | L |
|  |  |  |  |
| 4PCS | 4PCS | 4PCS | 4PCS |

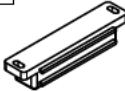

x2

STEP: 10

| | | |
|--|---|---|
| F | I | J |
|  |  |  |
| 2PCS | 4PCS | 24PCS |

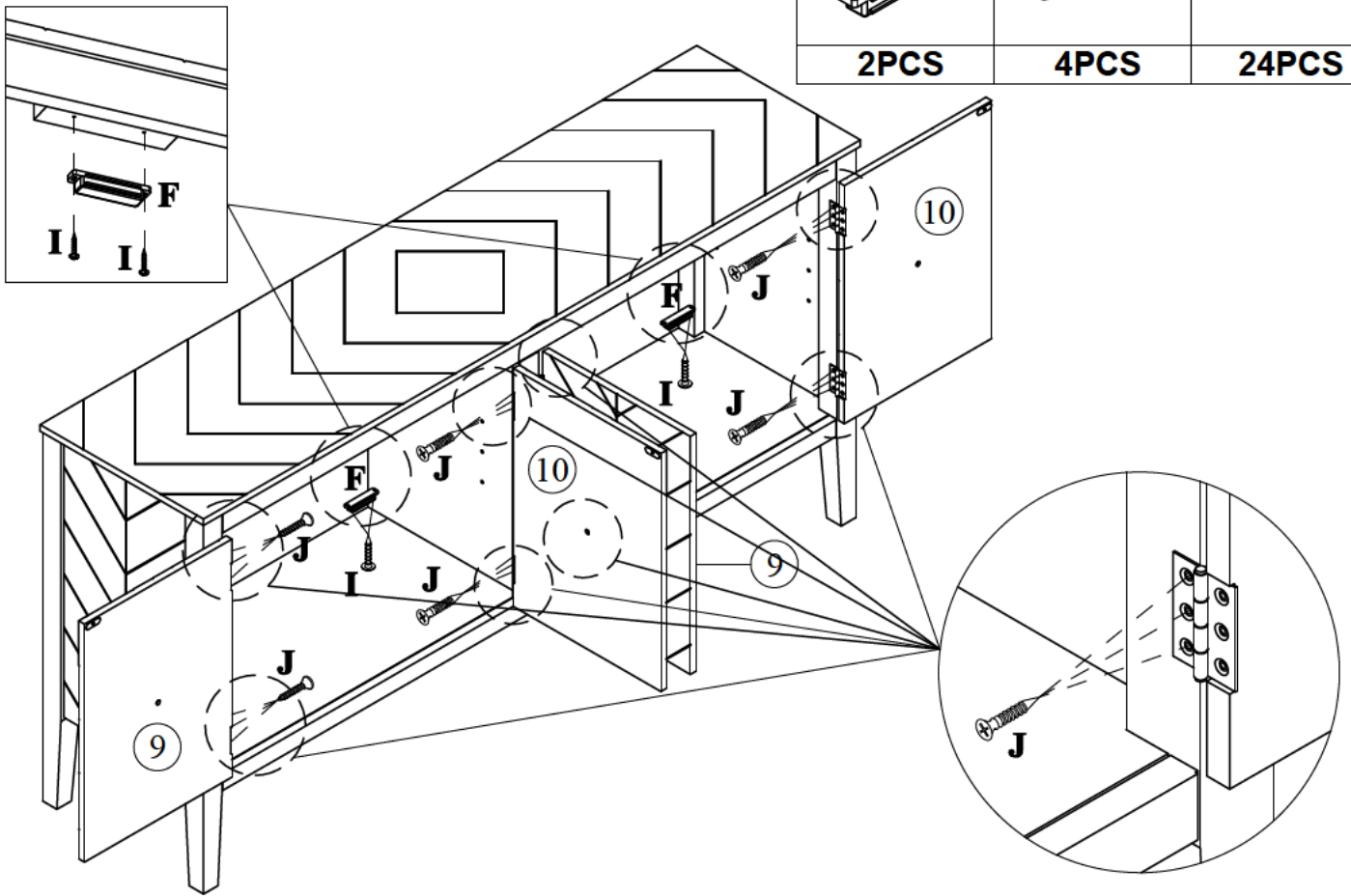

STEP: 11

M



8PCS

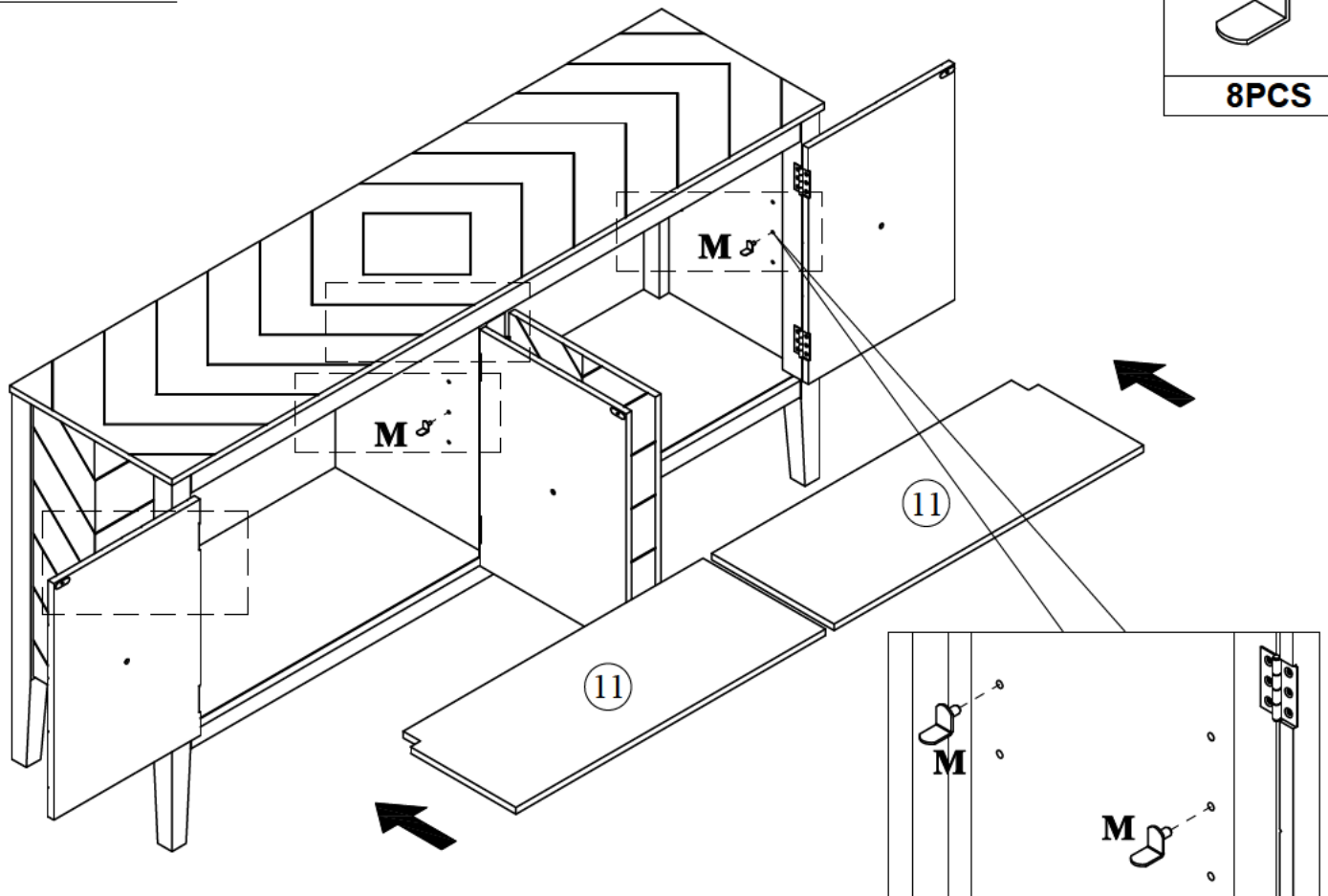

STEP: 12



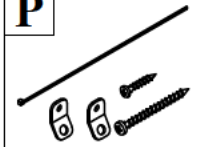

P

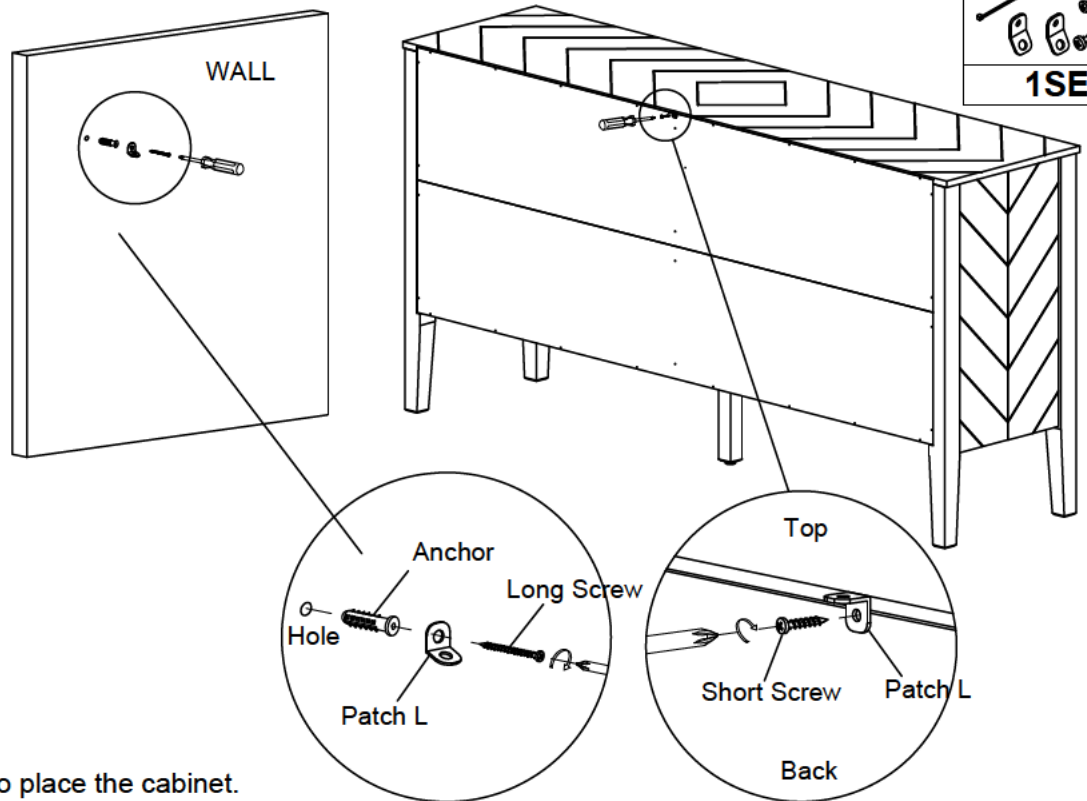

1SET



- Select the location to place the cabinet.
- Drill a hole in the dry wall to fit Anchor
Then included the Patch L with Long screw.
- Assembly the Patch L to the cabinet and affix by Short screw.

| | | | | |
|--|---|---|---|---|
|  |  |  |  |  |
| x2 | x1 | x1 | x1 | x1 |

STEP: 13

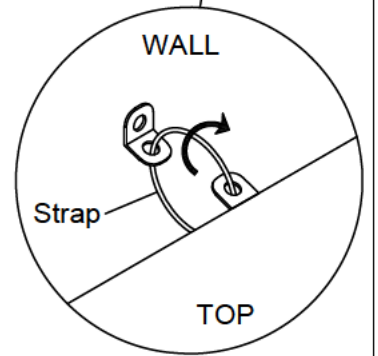
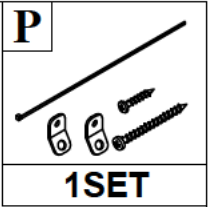
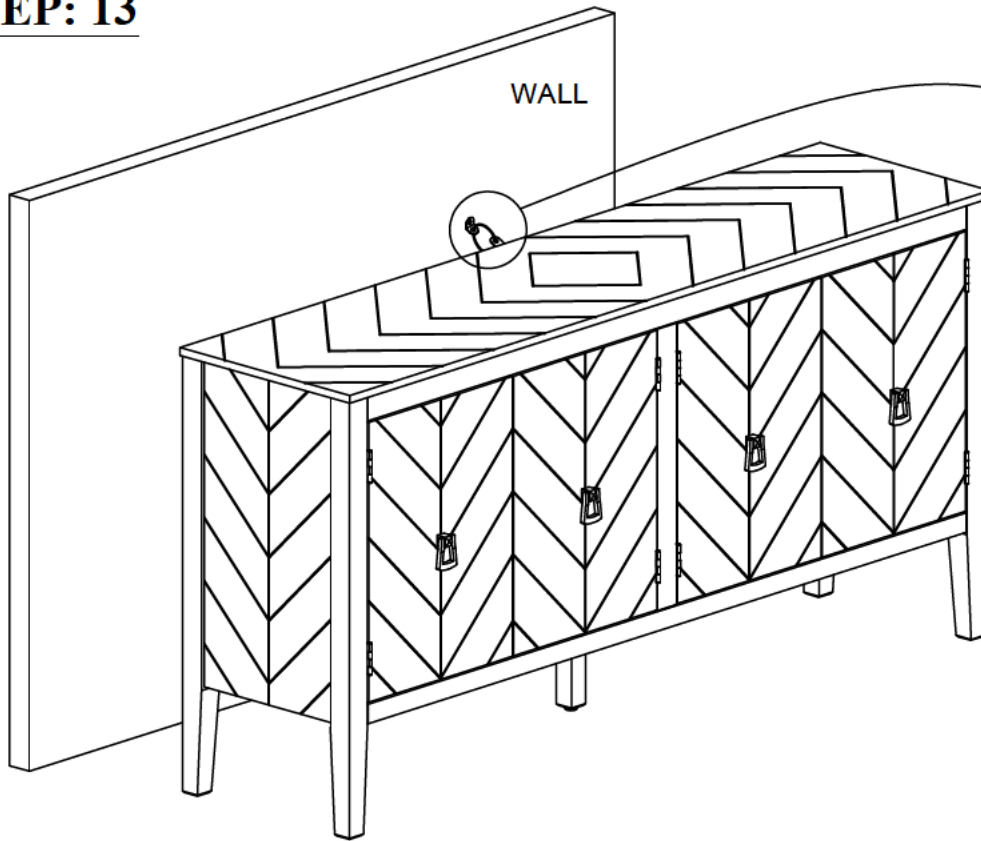

- Place the cabinet into position so both mounting Patch are vertically in line.
- Put the Strap into hole of Patch L then tighten the steel wire.

STEP: 14

