

## Upholstered bed

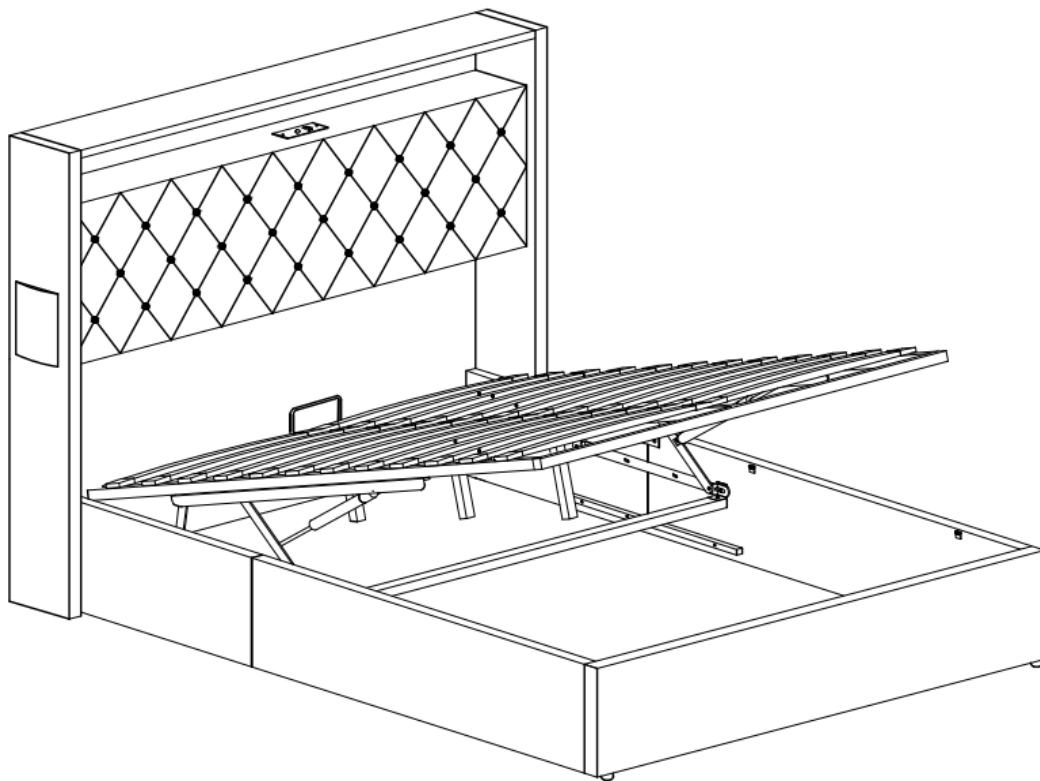

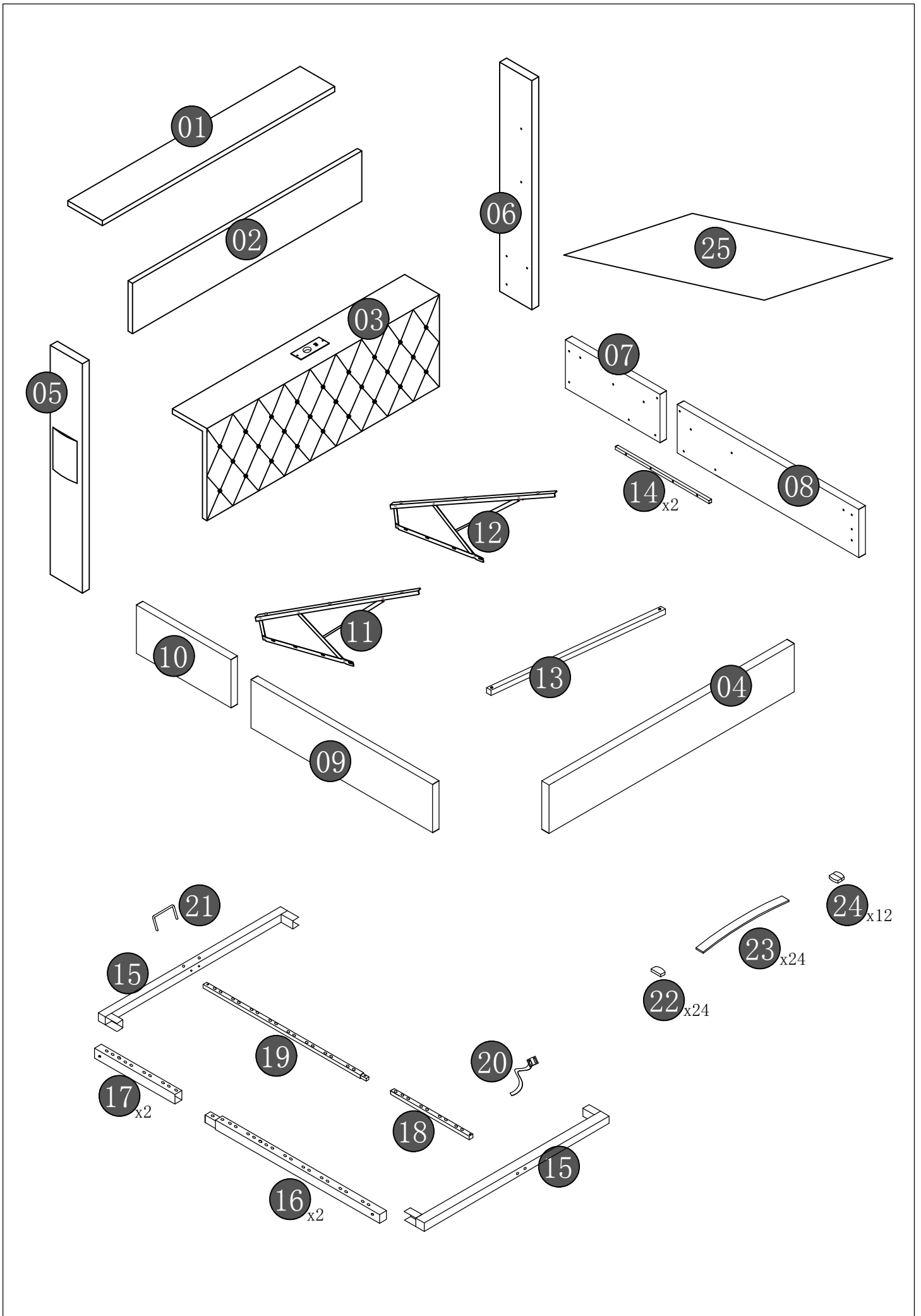









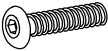
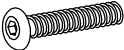



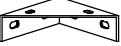







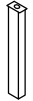

### TIPS

1. This product is divided into 2 parcels for delivery. They may not arrive at the same time. Please wait patiently.
2. Please read the instructions fully before assembly. These instructions include important information which could ensure correct assembly. We have been working on providing high quality products for you. However, in the rare instance that your product is defective, missing parts or there are some issues, please don't hesitate to contact our customer service to submit parts requirements, assembly suggestion, or warranty claims, and we will give the best solution as soon as possible. If necessary, we need you to provide some more clear pictures of the issue.
3. Insert the screws in holes and tighten the screws, but not too tight, 70%~80% is ok, finally tighten all the screws. If some issues happened that some screws can not target to the hole or some parts are difficult to install, please adjust the tightness of the screws.
4. 2 people are recommended to finish.

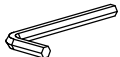
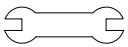

N652P221656

A	 8*18	46
B	 8*30	8
C	 8*40	2
D	 8*50	20
E	 3.5*20	12
F	 8*40	12
G		2
H		2
I		2
J		2
K		4
L		15
M		3
N		4

O	 21.5cm	3
P		2
Q		6
R	 2.5cm	2
S		4
T		2
U		8
V		1
W		1
X		1
Y		1
Z		1
a		1
b		1

# N652P221655

01<sub>x1</sub>

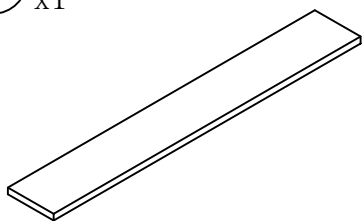

02<sub>x1</sub>

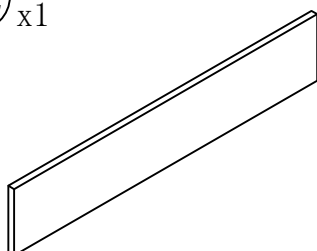

03<sub>x1</sub>

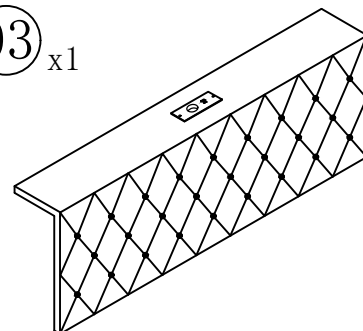

05<sub>x1</sub>



06<sub>x1</sub>



13<sub>x1</sub>

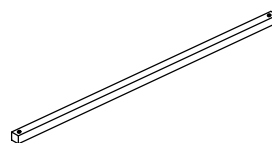

15<sub>x2</sub>

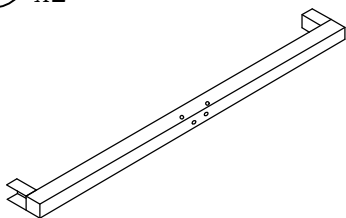

16<sub>x2</sub>

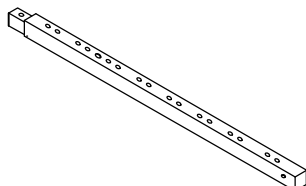

17<sub>x2</sub>

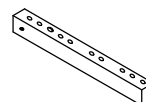

18<sub>x1</sub>

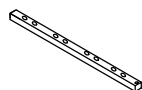

19<sub>x1</sub>

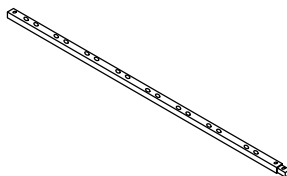

25<sub>x1</sub>

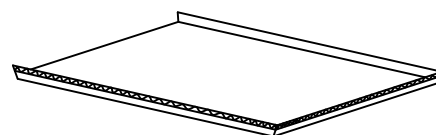

# N652P221656

04<sub>x1</sub>

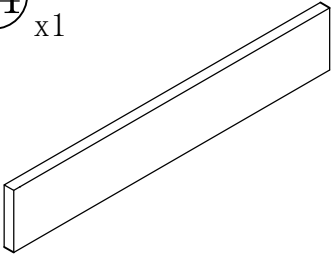

07<sub>x1</sub>

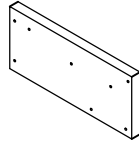

08<sub>x1</sub>

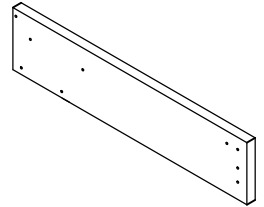

09<sub>x1</sub>

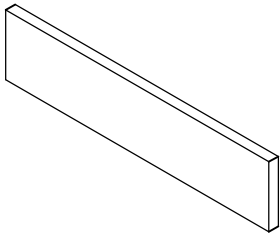

10<sub>x1</sub>

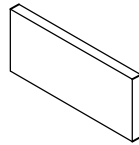

11<sub>x1</sub>

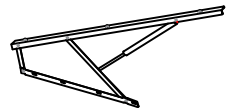

12<sub>x1</sub>

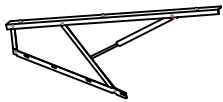

14<sub>x2</sub>

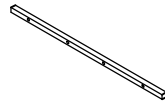

20<sub>x1</sub>

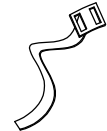

21<sub>x1</sub>



22<sub>x24</sub>



23<sub>x24</sub>

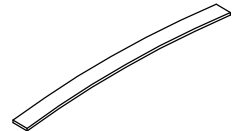

24<sub>x12</sub>



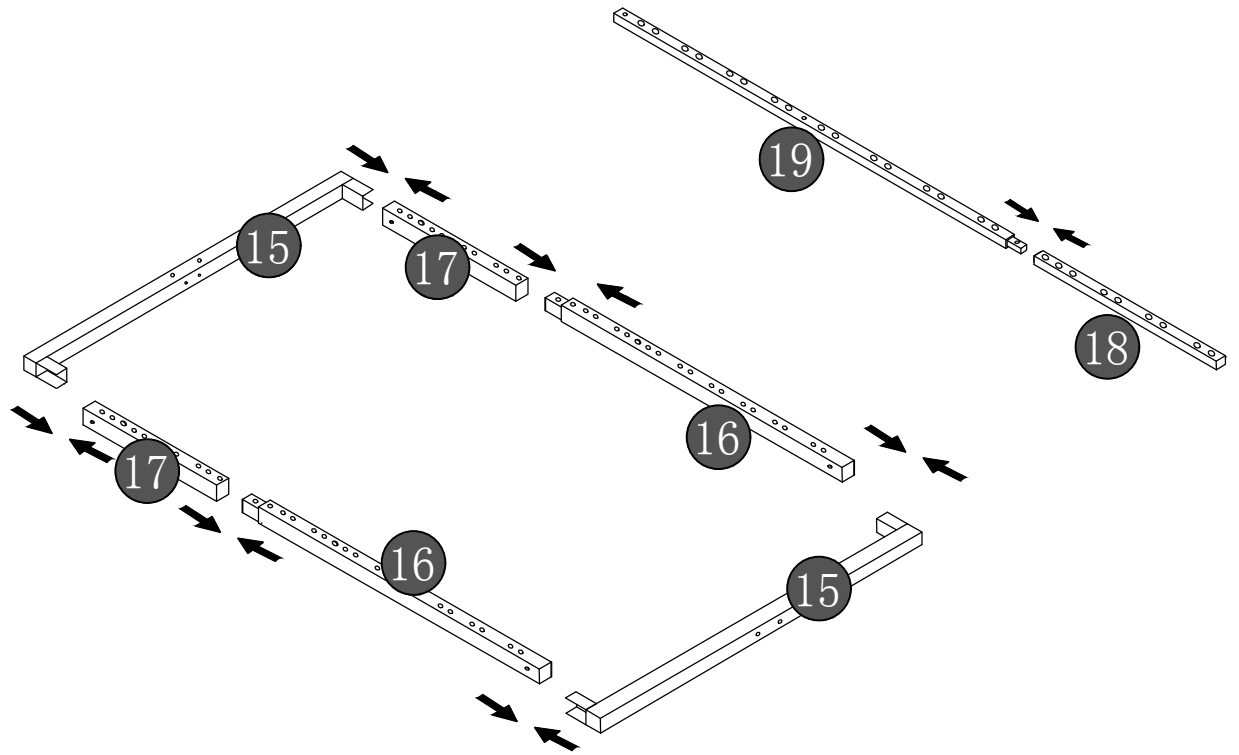

01

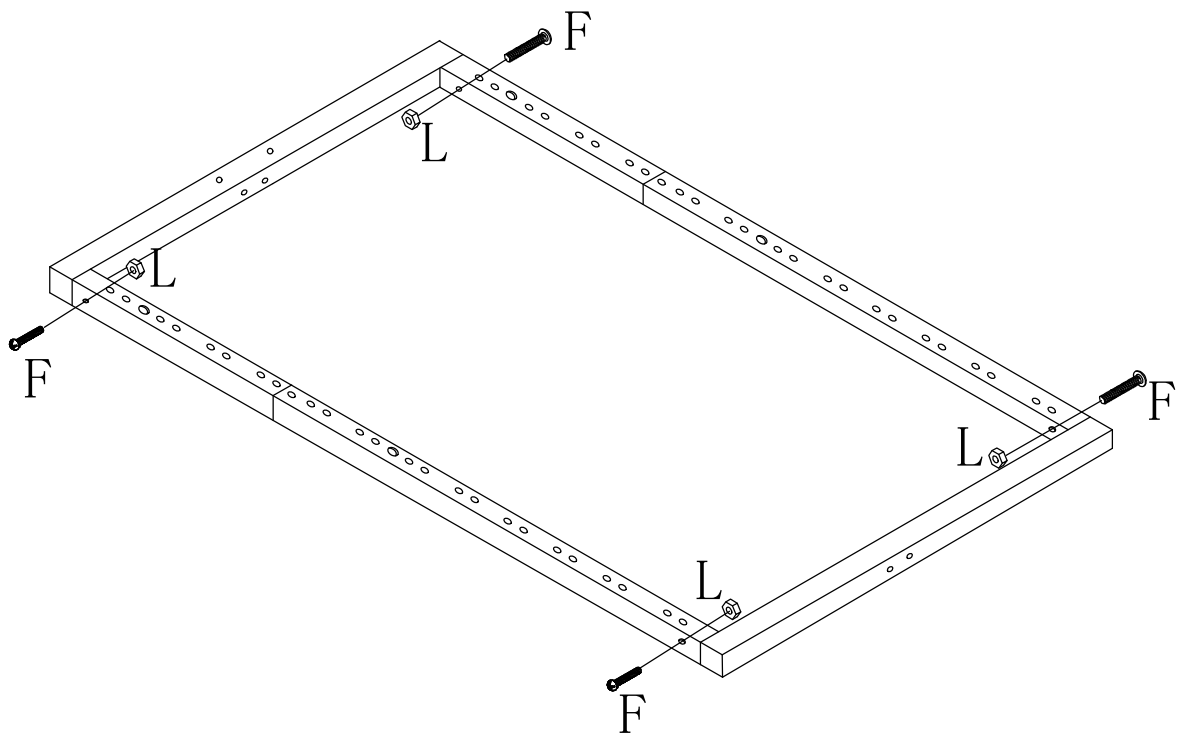

02

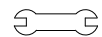



b		1
a		1

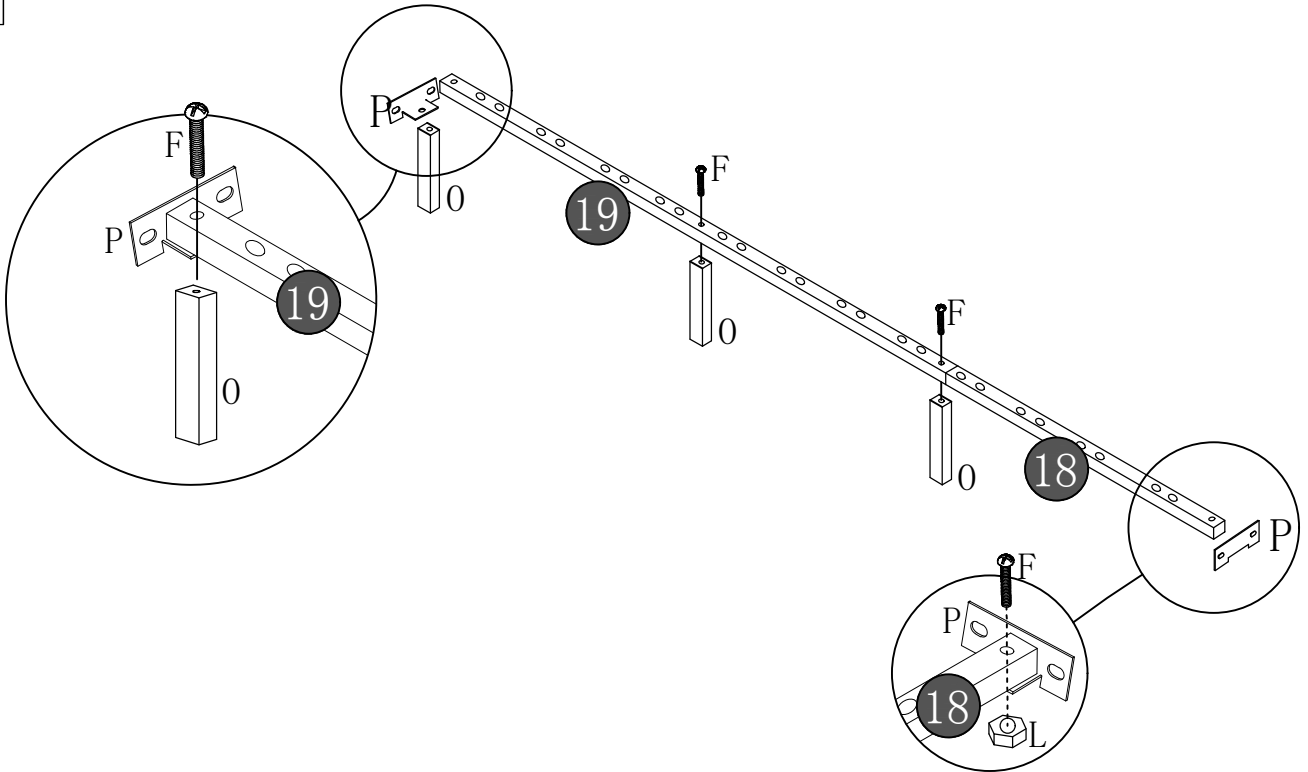

L		4	F		4
---	---------------------------------------------------------------------------------------	---	---	---------------------------------------------------------------------------------------	---

8\*40



03

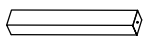

b		1
a		1

0		3	P		2
---	-------------------------------------------------------------------------------------	---	---	---------------------------------------------------------------------------------------	---



21.5cm

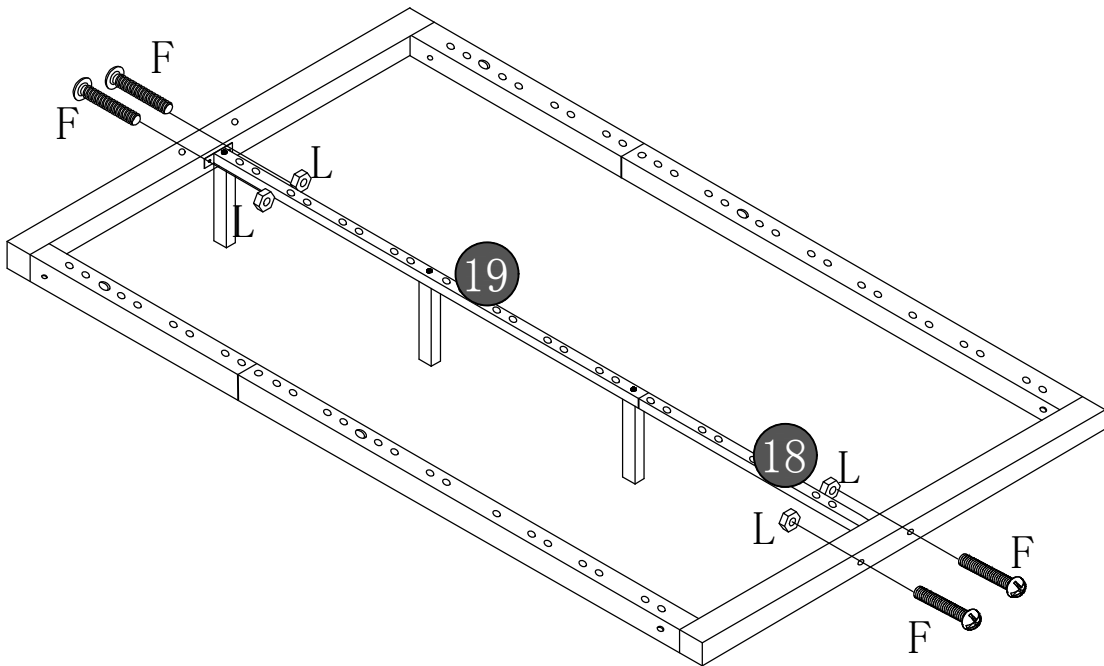

L		1
F		4

8\*40

04



b		1
a		1

L		4	F		4
---	---------------------------------------------------------------------------------------	---	---	---------------------------------------------------------------------------------------	---

8\*40



07

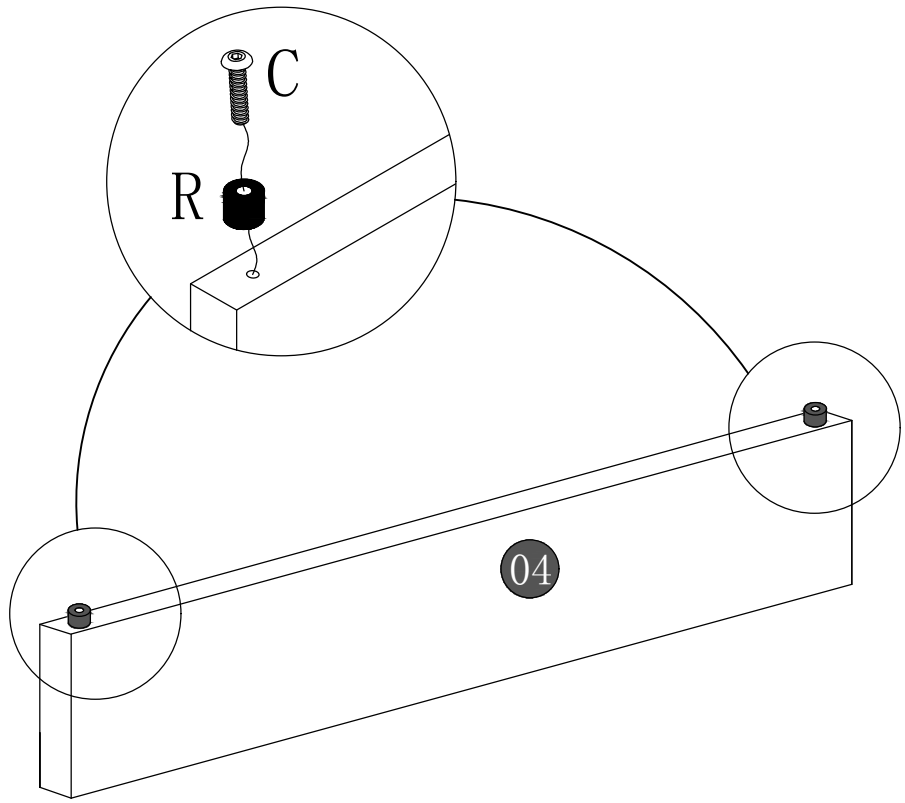

Z		1
---	--	---

B		8*50
D		8*50
A		8*18

R		2.5cm	2
C		8*40	2

08

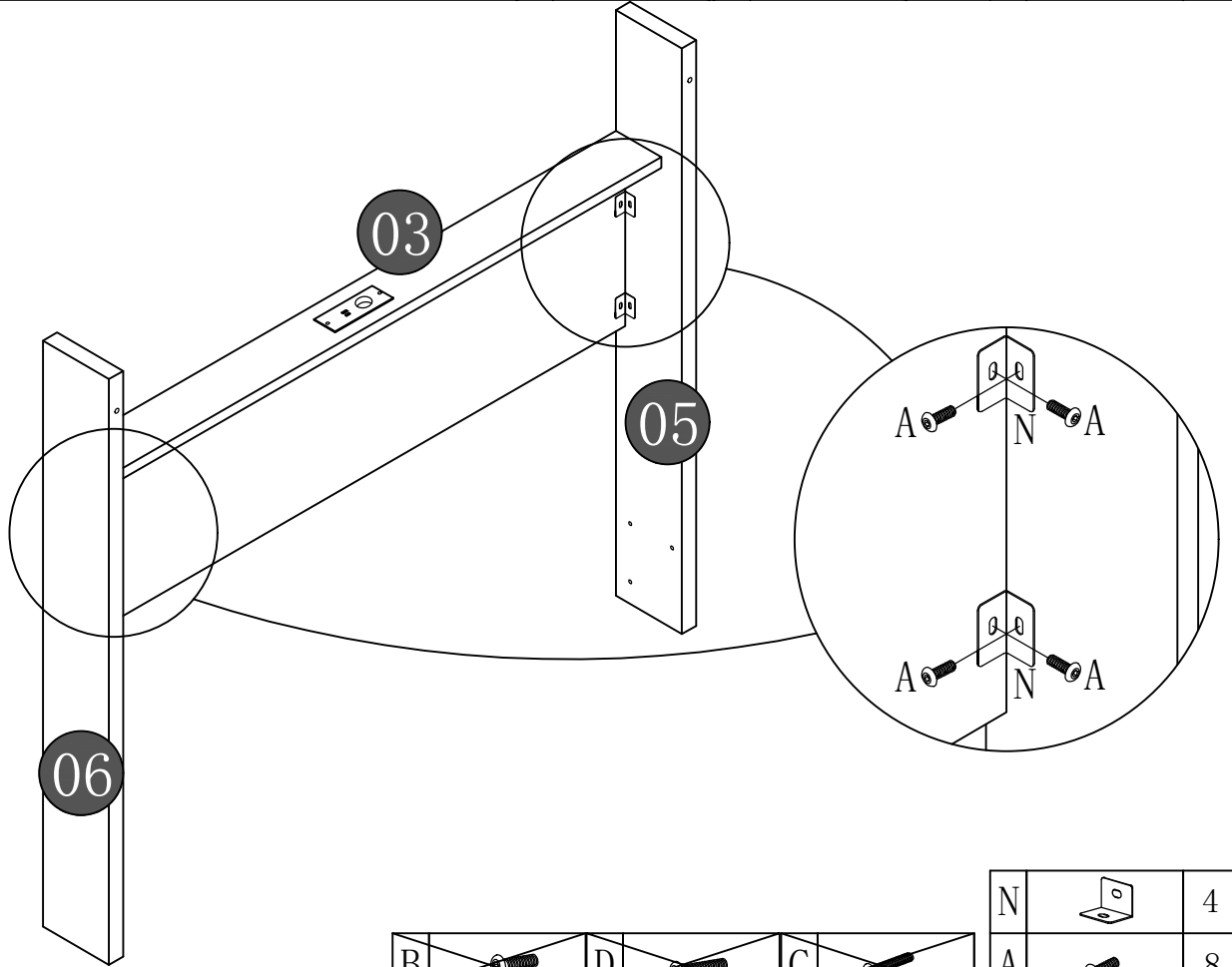

Z		1
---	--	---

B		8*50
D		8*50
C		8*40

N		4	
A		8*18	8

09

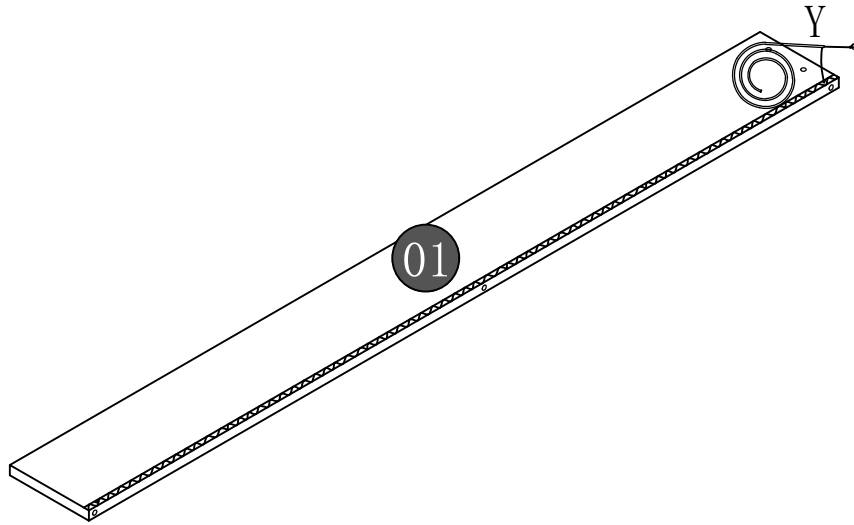

Y		1
---	--	---

10

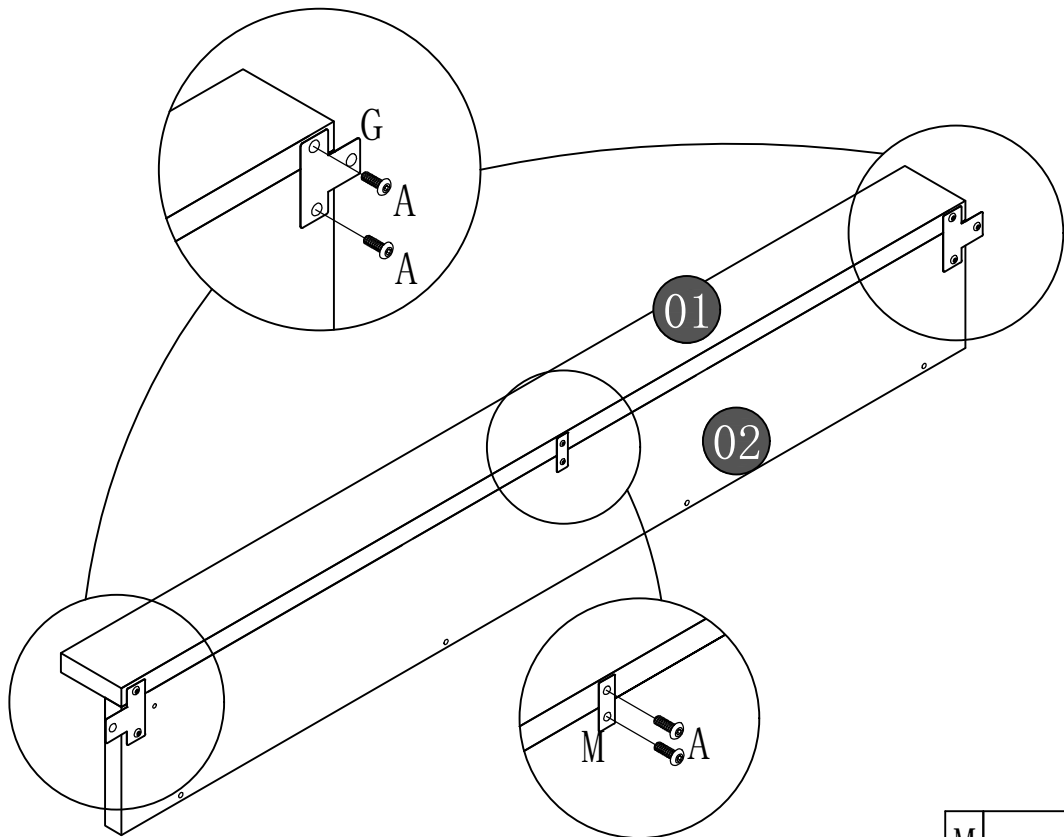

M		1
A		6

Z		1	B		D		C	
---	--	---	---	--	---	--	---	--

G		2
---	--	---

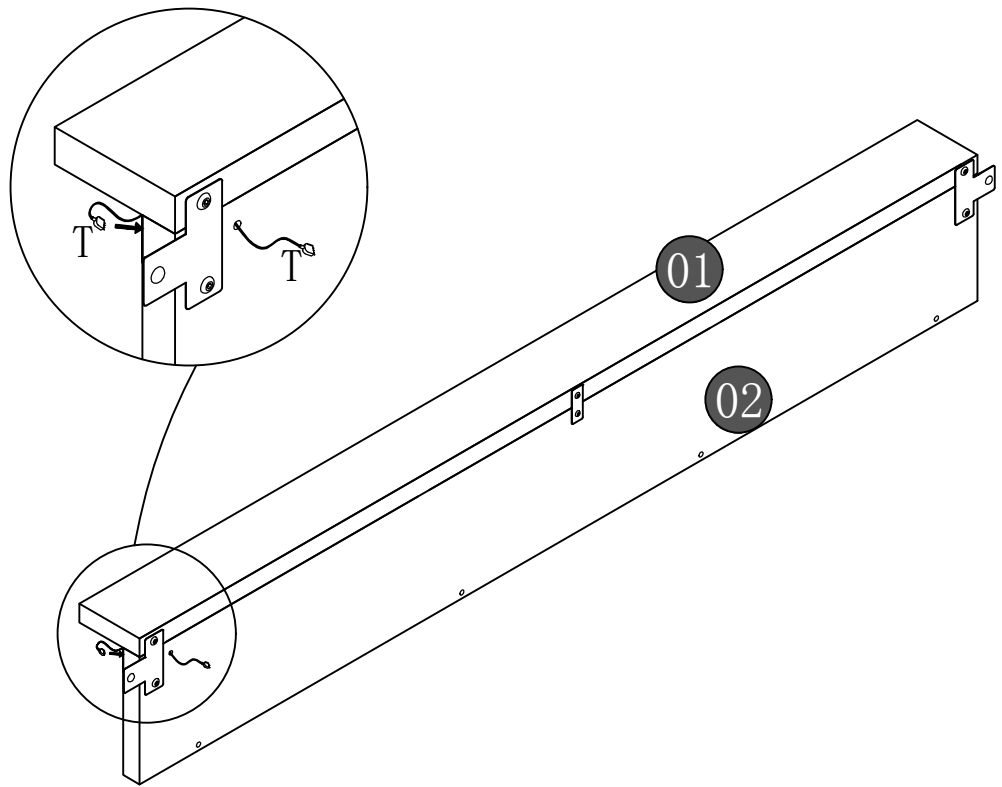

11



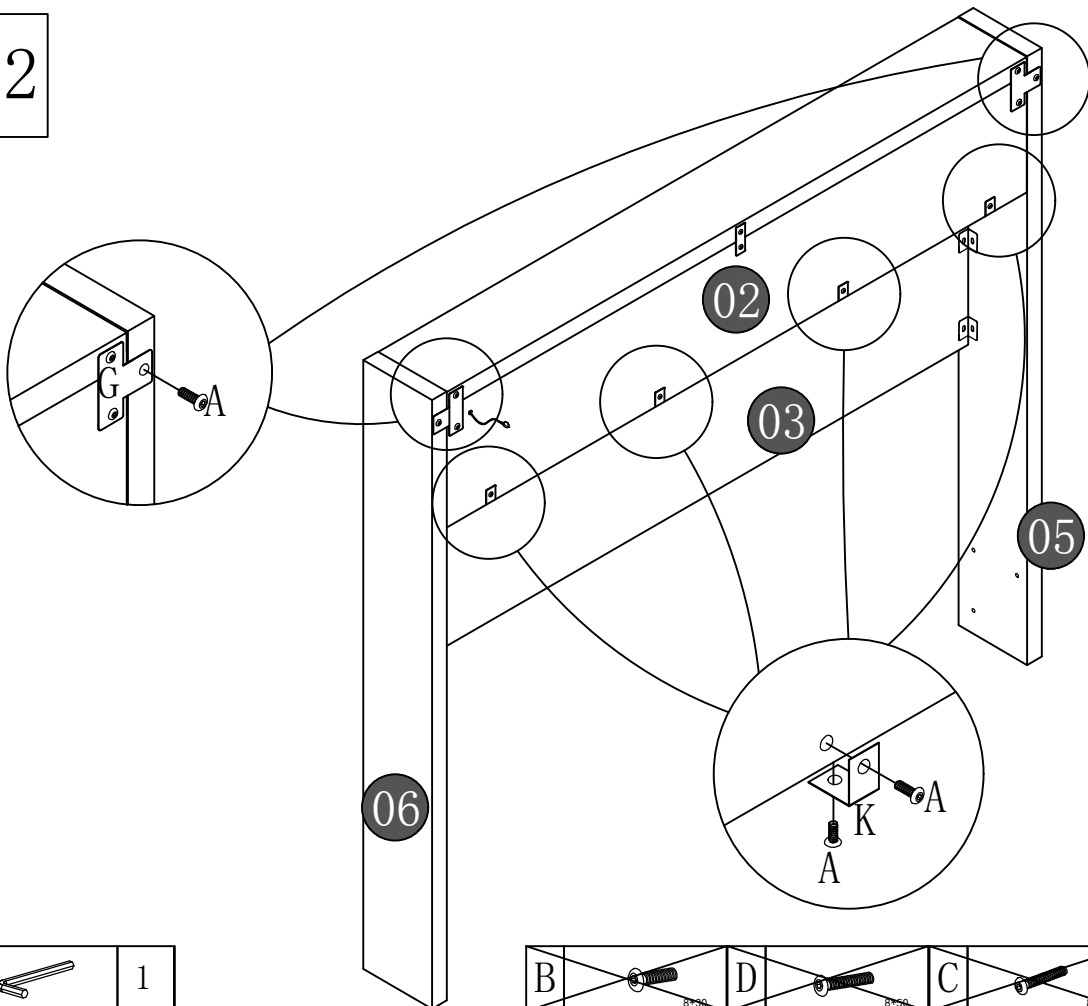

12



Z		1
---	-------------------------------------------------------------------------------------	---

B		D		C	
---	-------------------------------------------------------------------------------------	---	--------------------------------------------------------------------------------------	---	---------------------------------------------------------------------------------------

K		4
A		10

13

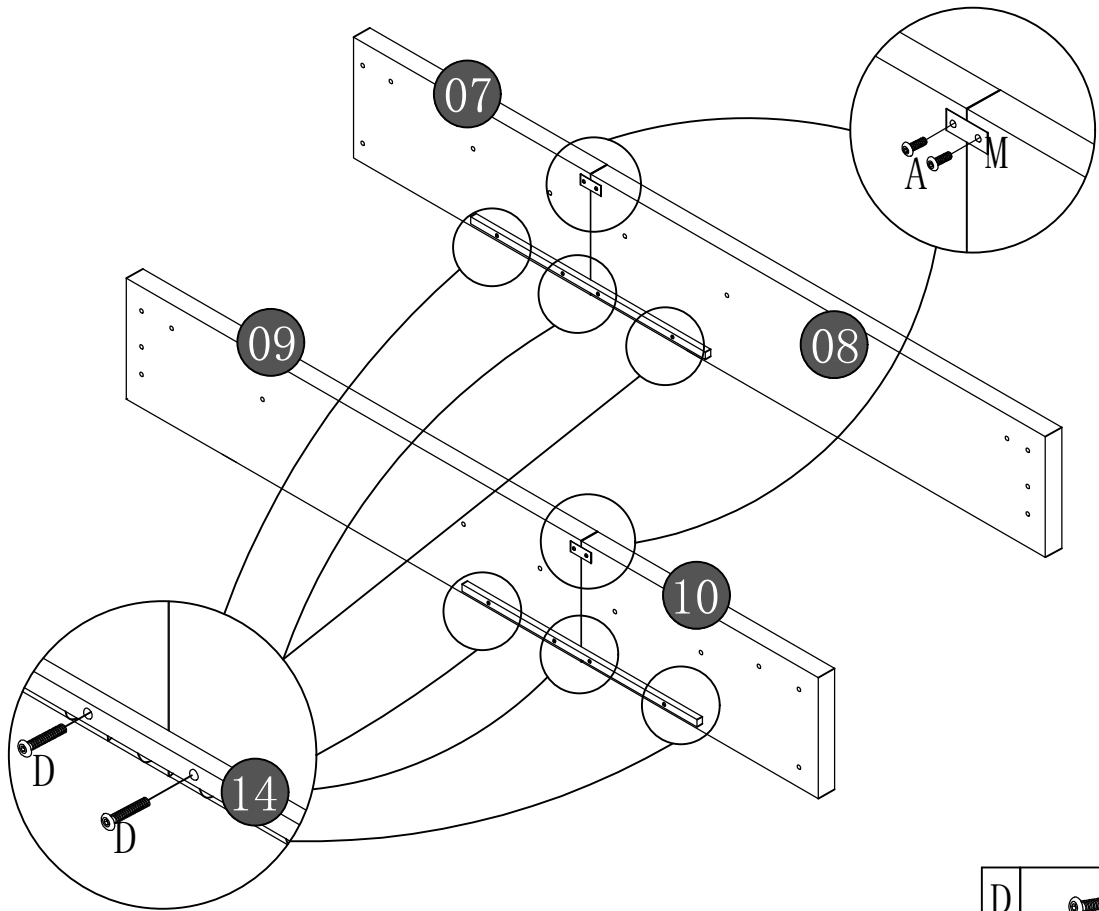

Z		1
---	--	---

B		C		M		2
---	--	---	--	---	--	---

D		8
A		4

14

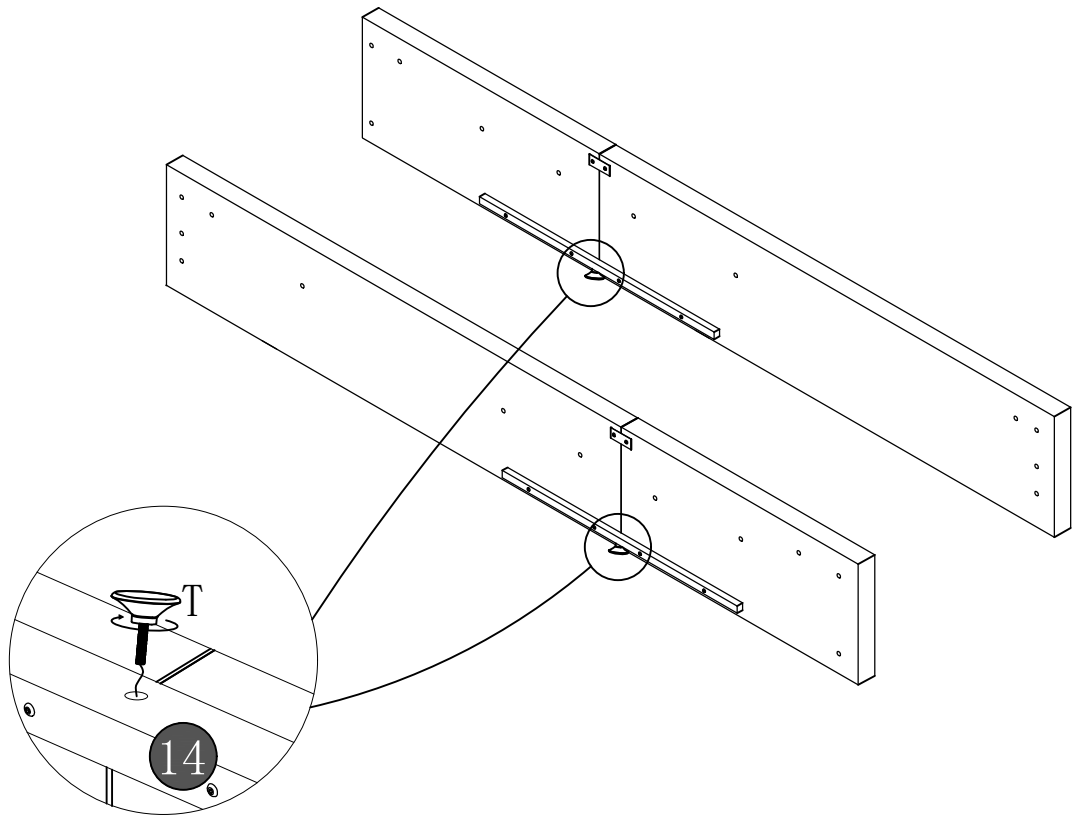

T		2
---	--	---

15

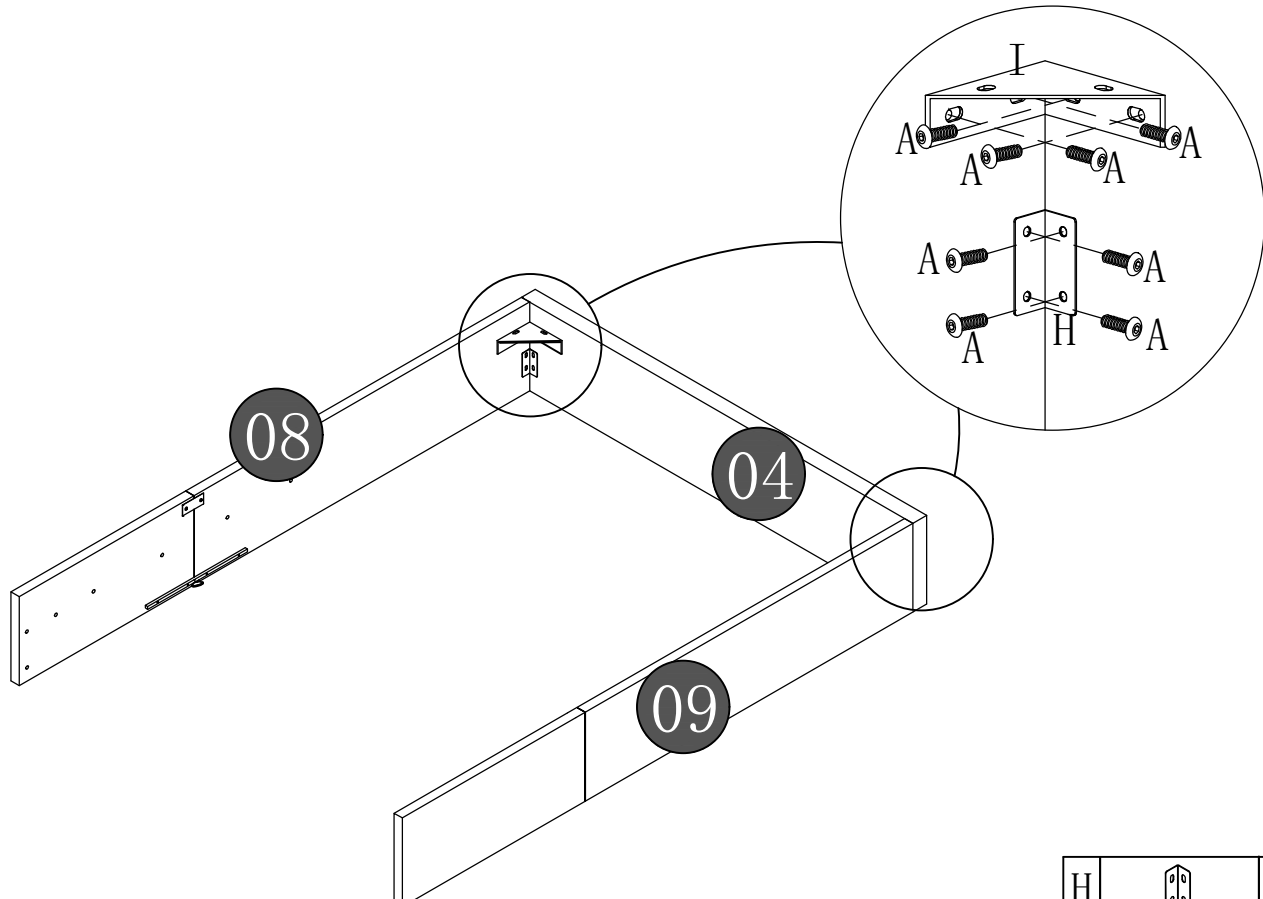

Z		1	B		D		C		I		2	H		2
				8*50		8*50		8*40				A		16

16

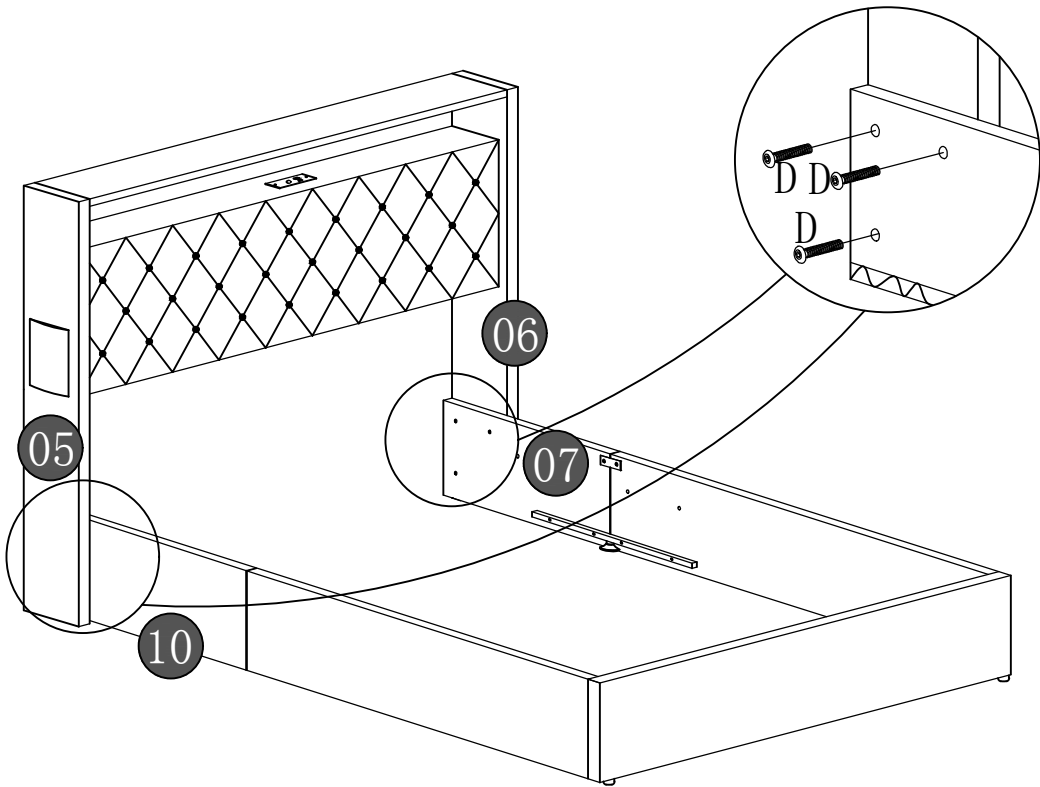

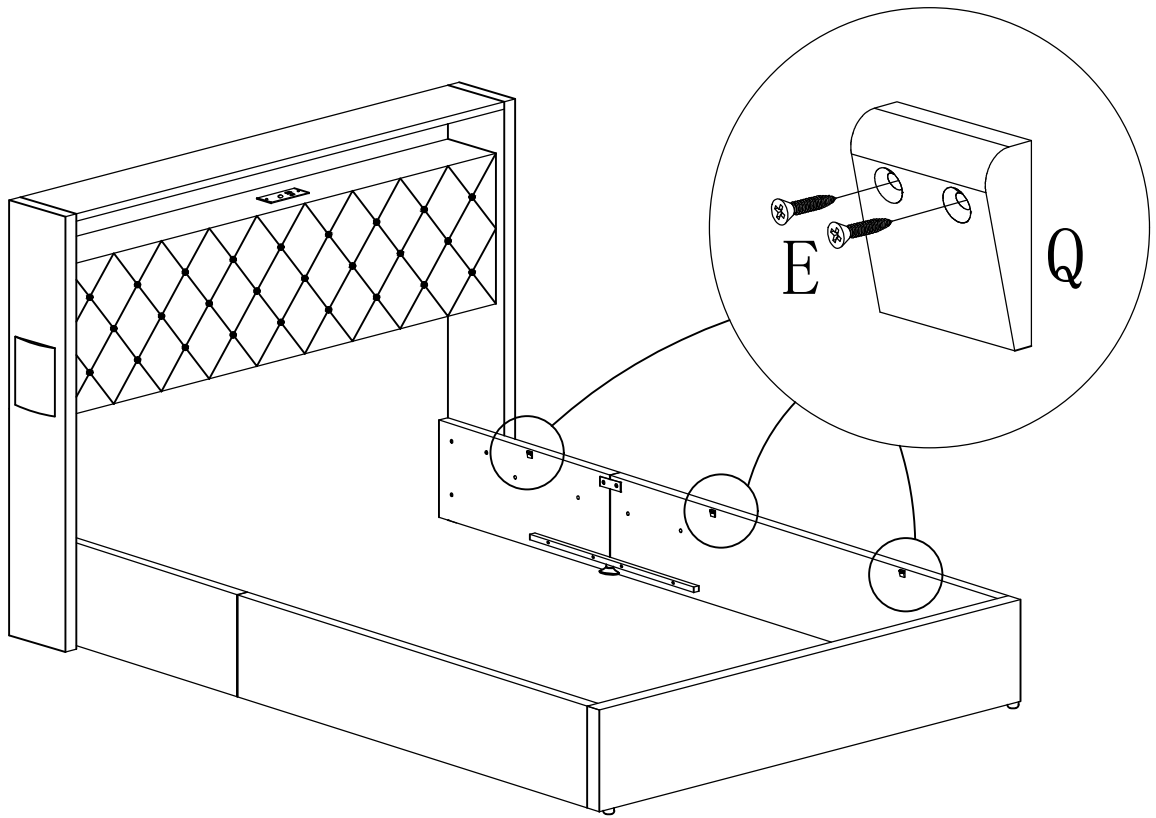

Z		1	A		B		C		D		6
				8*18		8*50		8*40		8*50	

17







b		1
---	-------------------------------------------------------------------------------------	---

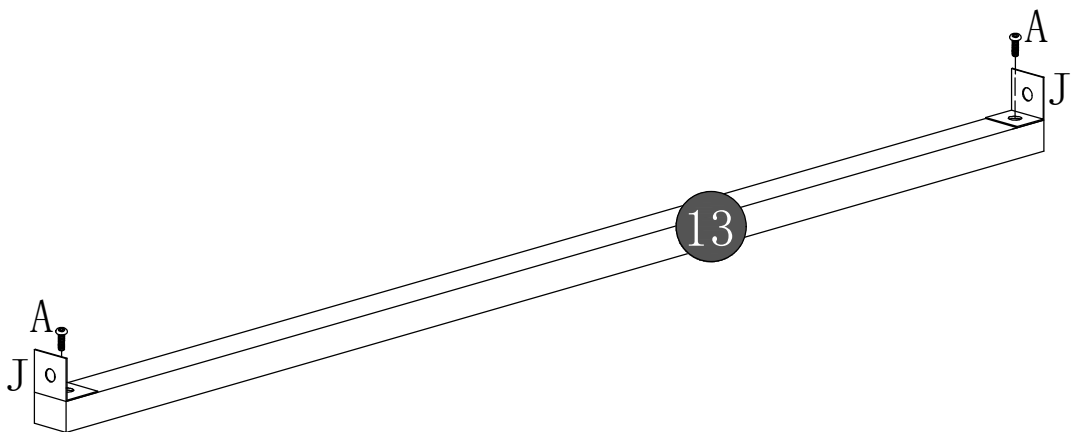

Q		6
E	 3.5*20	12

18





Z		1
---	-------------------------------------------------------------------------------------	---



B	 8*50	
D	 8*50	
C	 8*40	

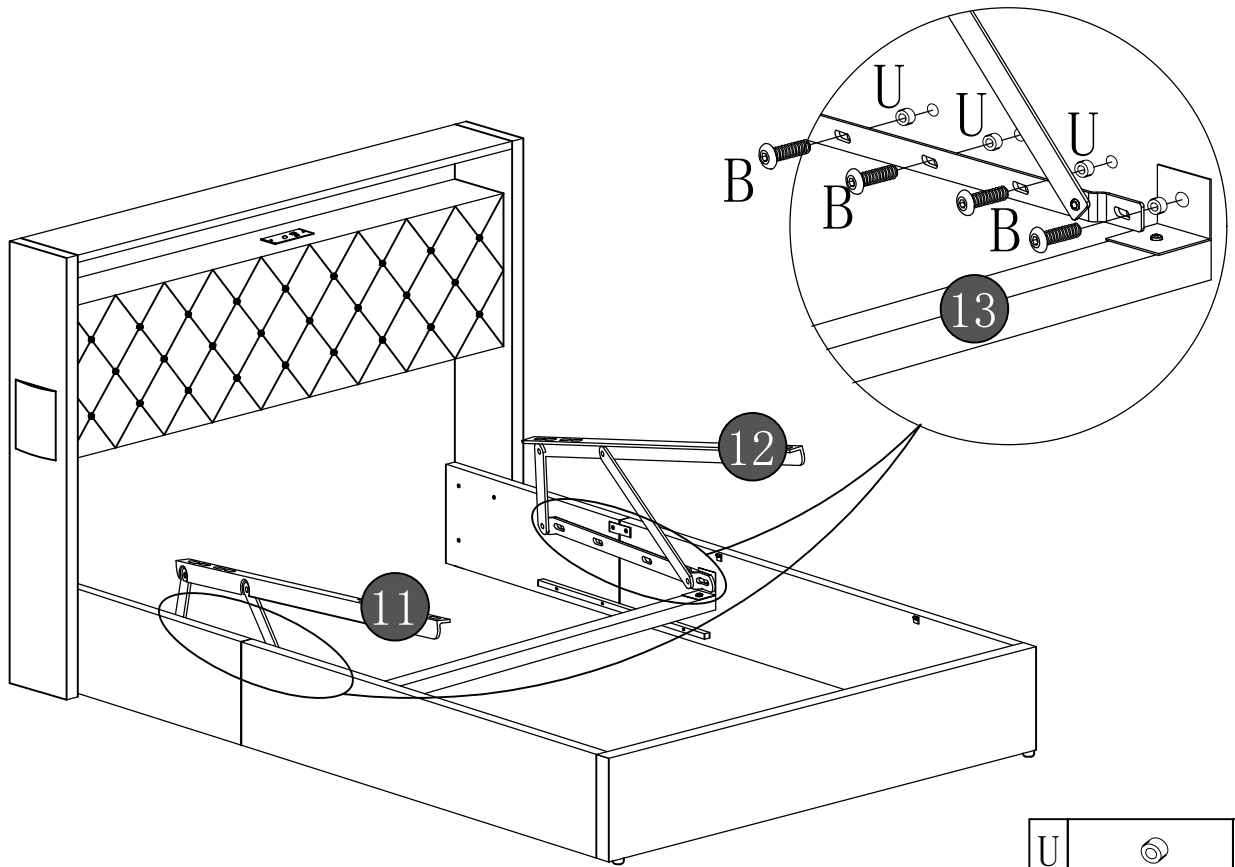

A	 8*18	2
J		2

19



Z		1
---	-------------------------------------------------------------------------------------	---

A		D		C	
	8*16		8*56		8*16



U		8
B		8
	8*30	

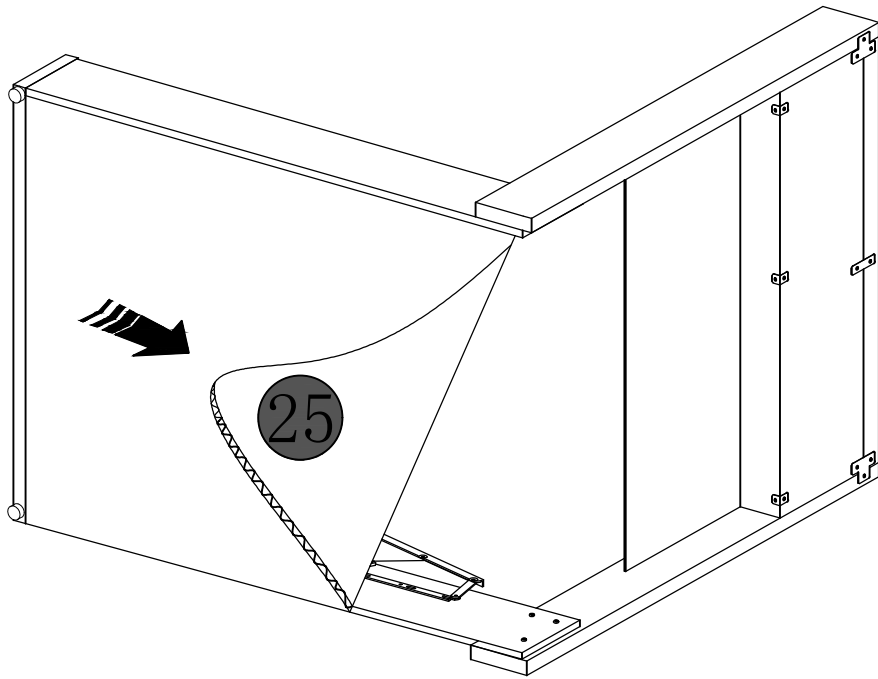

20

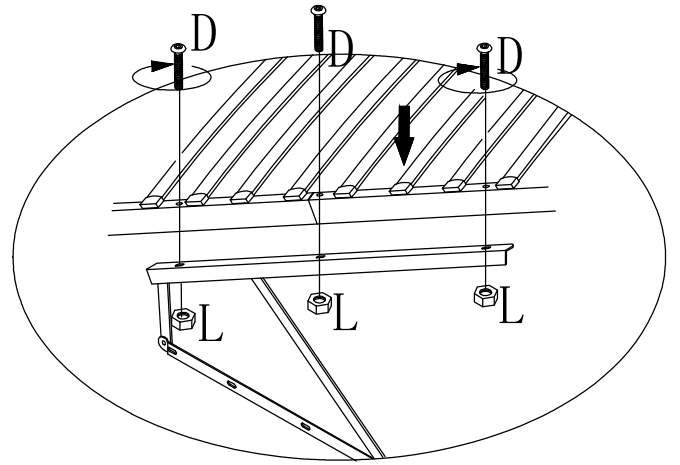
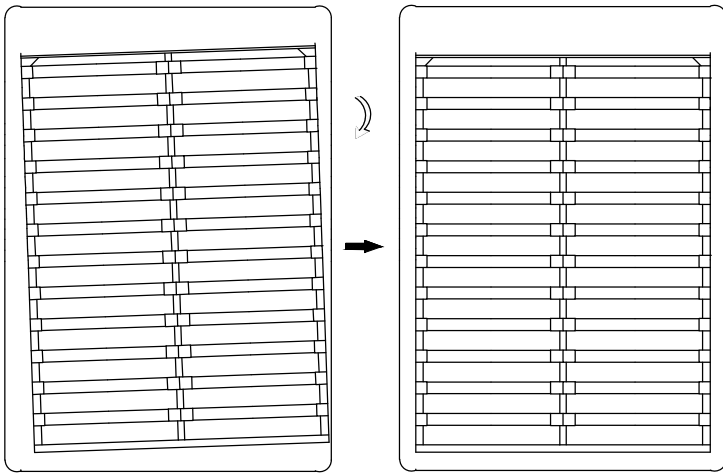



21





a		1
Z		1

B		8*30	C		8*46	A		8*16
---	-------------------------------------------------------------------------------------	------	---	--------------------------------------------------------------------------------------	------	---	---------------------------------------------------------------------------------------	------

L		6
D		8*50

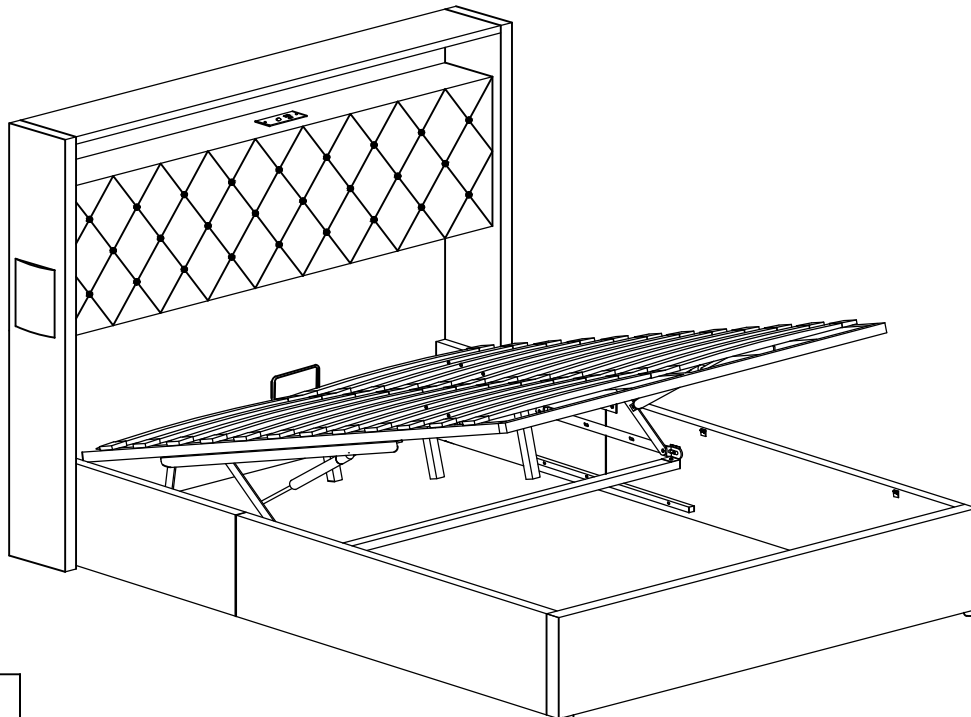
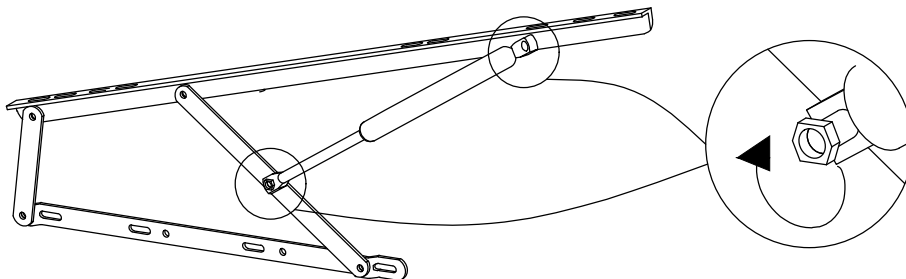

22

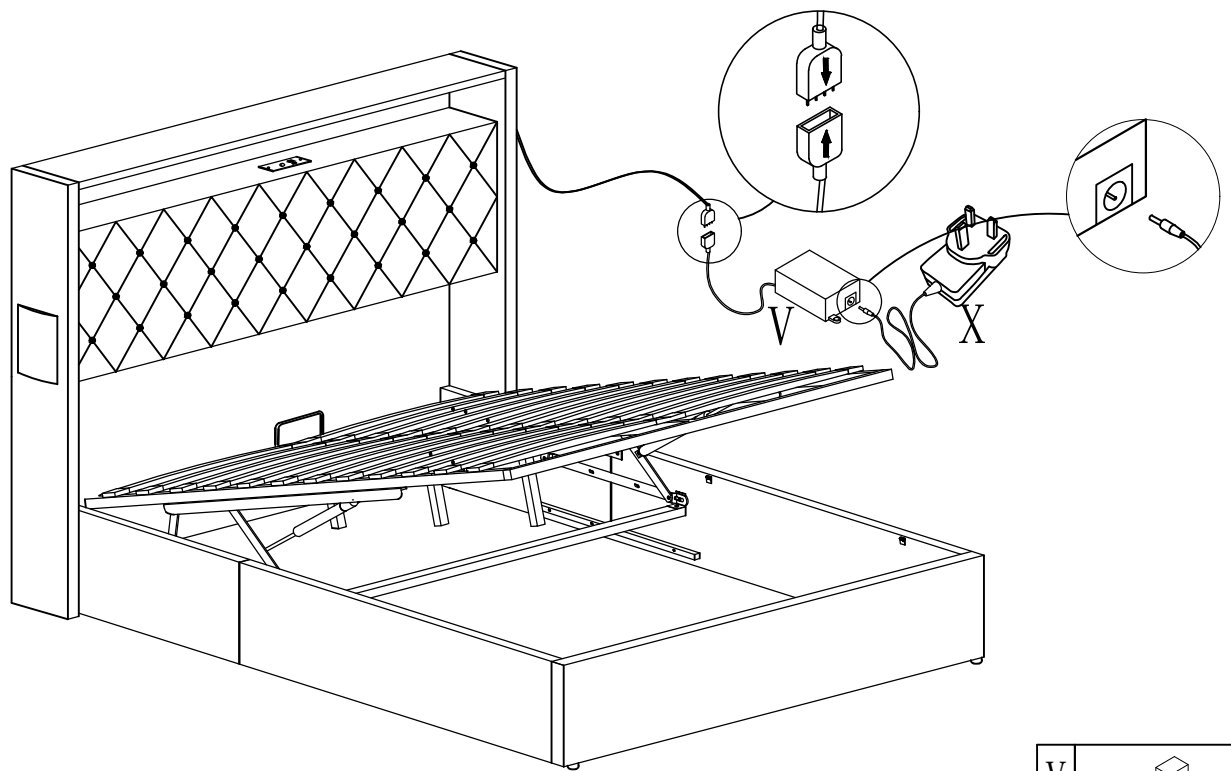

a		1
---	-------------------------------------------------------------------------------------	---

23



V		1
X		1

24

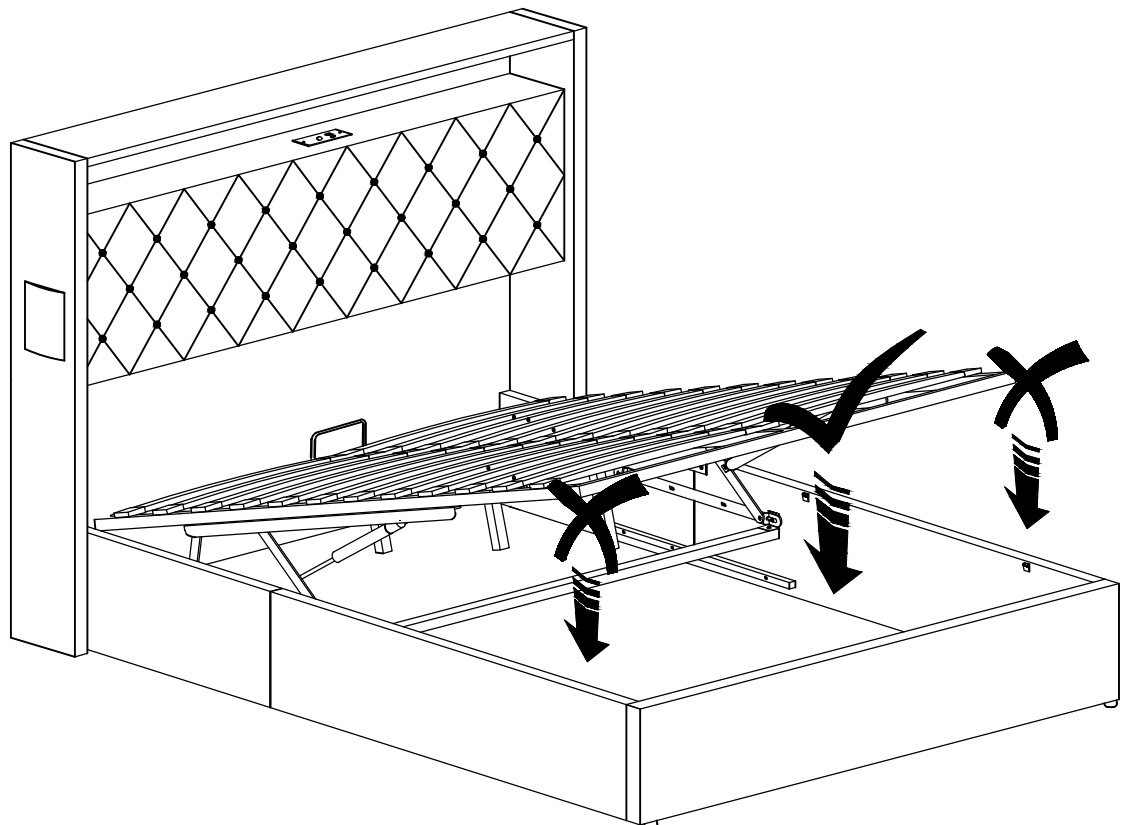

# USER MANUAL

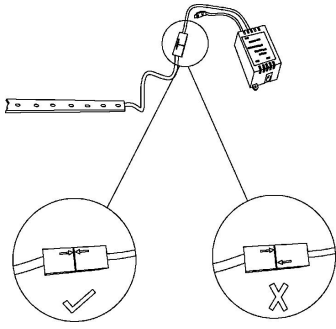

1. When you connect LED light with the LED control, please make sure the plugs remain arrow to arrow

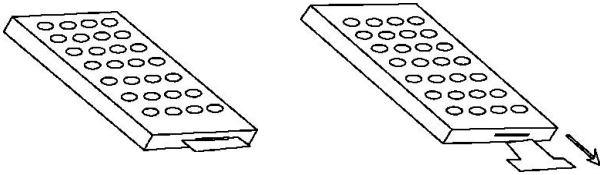

2. Before you using the remote controller, please remove the transparent plastic, which is designed to disconnect the battery

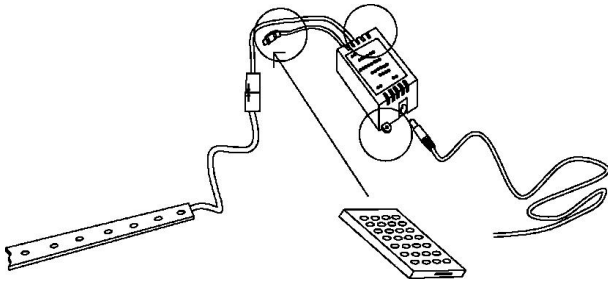

3. Remote controller should be aim at the black receiver unit when you switch colours, you can also fix the control box on the nearby wall with 2 screws, for more convenient using

## I .Specifications:

**Working temperature:**-20-60°C  
**Product size:**L50×W35×H22mm  
**Output:**Three CMOS drain-open output  
**Package size:**L95×W60×H40mm  
**Max load current:**2A each color  
**Net weight:**46.5g  
**Gross weight:**71g

## II .Control Method:

Adopt IR remoter to control the led controller,which has 24 buttons,the function of each button as the table below:

Brightness+(16 in all)	Brightness-(16 in all)	Off	On
Static red	Static green	Static blue	Static white
Static orange	Static pea green	Static dark blue	7 color jumpy/fade change
Static dark yellow	Static cyan	Static brown	All the monochromatic jump
Static yellow	Static light blue	Static pink	All the monochromatic fade
Static straw yellow	Static sky blue	Static purple	3 color jumpy/fade change

Direction:press static color every time,the matching mode flicker two times before stopping,then recover the static color.When switching to four dynamic mode (7 color jump change.All fade out & fade in,7 color fade change,3 base color jumpy),the button of "Brightness+"/"Brightness-" means the speed of light change is up/down,there are 32 step in all.

## III .Panel specification and connecting drawing as follows:

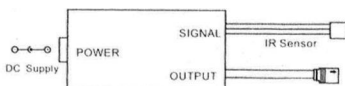

## IV .Warning:

- The input voltage of this controller should be follow the specifications,other high voltage would most probably destroy it.
- Lead wire should be connected correctly according to colors that connecting diagram offers.
- Warranty of this product is one year,but exclude the artificial situation of damaged of overload working.

## LED light

If you can't let the lights work successfully,please check the following:

- Please check the direction of the connect,try it in the opposite direction,according to the following picture.
- Please check the remote control,it need you to tear down the plastic septum before use it.
- If one of the colors is not bright, please check whether the four wires in the plug are skewed, and move the main line to make the four wires flush.

## ! WARNING

**THIS PRODUCT CONTAINS A BUTTON BATTERY**  
 If swallowed, a lithium button battery can cause severe or fatal injuries within 2 hours.

Keep batteries out of reach of children.

If you think batteries may have been swallowed or placed inside any part of the body, seek immediate medical attention.



# Declaration of Conformity

**Certificate No.** : AOCE240301111-EC  
**Applicant** : Zhongshan Quanluo Lighting Co., Ltd.  
**Address** : 5th Floor, Building 2, No. 3, Yongyi 6th Road, Yongxing Industrial Zone,  
Henglan Town, Zhongshan City, Guangdong Province  
**Product** : LED Light Strip  
**Trademark** : /  
**Model(s)** : KB72RGB-S5050-12V, KB120RGB-S5050-12V, KB60RGB-S5050-12V,  
KB30RGB-S5050-12V, KB72RGB-S5050-24V, KB120RGB-S5050-24V,  
KB60RGB-S5050RGB-24V, KB30RGB-S5050-24V, KB120S2835-12V,  
KB60S2835-12V, KB180S2835-12V, KB240S2835-12V, KB120S2835-24V,  
KB60S2835-24V, KB180S2835-24V, KB240S2835-24V, KB180HCSS-12V,  
KB240HCSS-12V, KB180HCSS-24V, KB240HCSS-24V, KB384COB-12V,  
KB480COB-12V, KB480COB-24V, KB180COB-12V, KB196COB-12V,  
KB320COB-12V, KB400COB-12V, KB320COB-24V, KB240COB-24V,  
KB312COB-24V, KB360COB-24V, KB480COB-24V, KB400COB-24V,  
KB512COB-24V  
**Manufacturer** : Zhongshan Quanluo Lighting Co., Ltd.  
**Address** : 5th Floor, Building 2, No. 3, Yongyi 6th Road, Yongxing Industrial Zone,  
Henglan Town, Zhongshan City, Guangdong Province  
**Test Report** : AOCE240301111-E

Complies with the requirements of the  
**EC EMC directive 2014/30/EU** with amendments.

Test Standards:

**EN IEC 55015:2019+A11:2020**  
**EN 61547: 2009**  
**EN IEC 61000-3-2:2019+A1:2021**  
**EN 61000-3-3: 2013+A1:2019+A2:2021**

Remarks:

The **CE** markings as shown below can be affixed on the product after preparation of necessary conformity documentation, as stipulated in article 10 of the Council Directive **93/68/EEC**.



**Zhongshan AOCE Testing Technology Co., Ltd.**

Disika, 1/F., No.42, Chang'an South Road, Henglan, Zhongshan, Guangdong, China.

Te:+86-0760-87553128 Web:www.aoce-lab.com Email:guanlilin@aoce-lab.com



# Declaration of Conformity



**Certificate No.** : STON210811372-SC  
**Applicant** : Zhongshan Quanluo Lighting Co., Ltd  
**Address** : 5th Floor, Building 2, No3, Yongyi Xixth Road, Yongxing Industrial Zone, Henglan Town, Zhongshan, Guangdong, China  
**Product** : LED Light Strip  
**Trademark** : /  
**Model(s)** : TH-KB-12200-24W, TH-KB-12200-12W, TH-KB-12200-36W, TH-KB-12200-48W, TH-KB-12200-60W, TH-KB-12200-9W, TH-KB-12200-15W  
**Manufacturer** : Zhongshan Quanluo Lighting Co., Ltd  
**Address** : 5th Floor, Building 2, No3, Yongyi Xixth Road, Yongxing Industrial Zone, Henglan Town, Zhongshan, Guangdong, China  
**Test Report** : STON210811372-S

Complies with the requirements of the  
EC LVD directive 2014/35/EU with amendments.

Test Standards:

BS EN 60598-1:2015+A1:2018

EN 60598-2-21:2015 used in conjunction with

EN 60598-1:2015+A1:2018

Remarks:

Based on the voluntary assessment of the product sample and technical file, we confirm that the above-mentioned product meets the requirements of the UK directive.

The UKCA mark as show below can be used, under the responsibility of the manufacturer or the importer, after completion of an UK declaration of conformity and compliance with all relevant UK.



**Guangdong STON Testing Technology Co., Ltd.**

1/F, No.42 ChangAn South Road, Henglan Town, Zhongshan City, Guangdong Province, China.

Tel: +86-0760-87553128 Web: [www.stoncert.com](http://www.stoncert.com) Email: [guanlilin@ggtcert.com](mailto:guanlilin@ggtcert.com)