

# Assembly Instruction

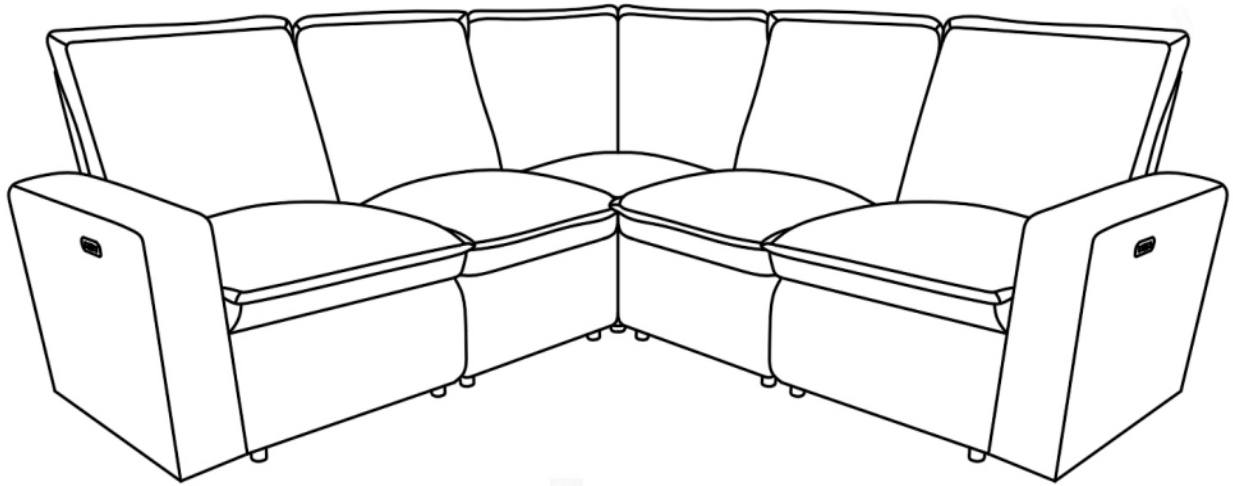

**WF306868/WF306869/WF306870/WF306871**

# PARTS

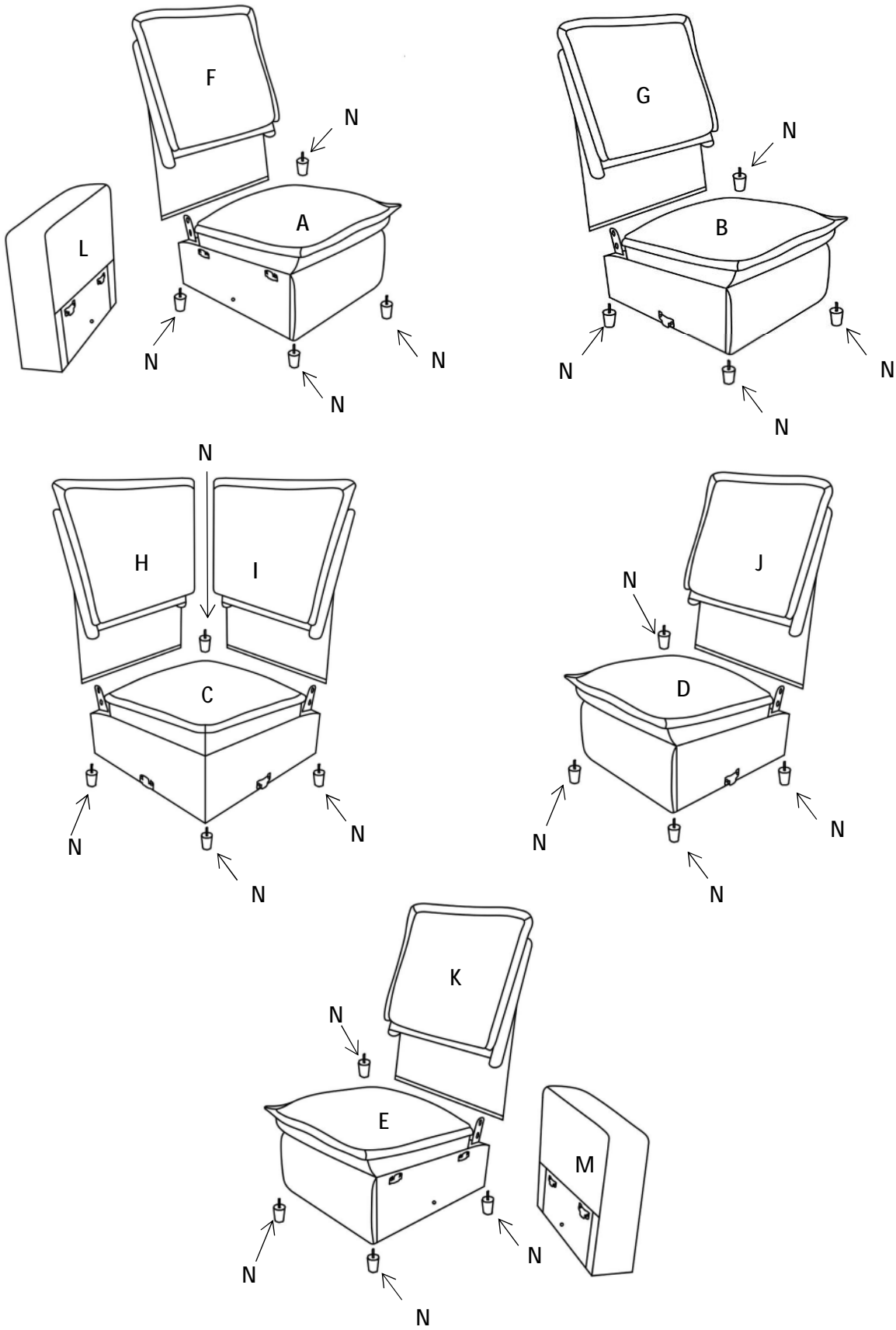

## PARTS LIST-BOX 1 SKU:WF306870

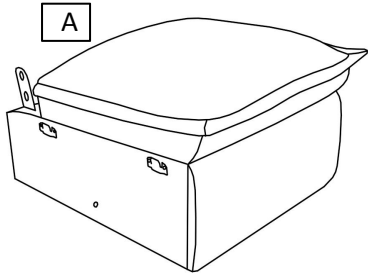

**Lhf Recliner Base X 1PC**

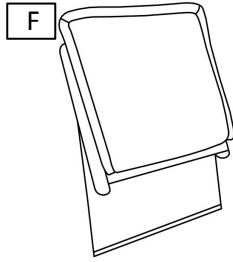

**Lhf Recliner Backrest X 1PC**

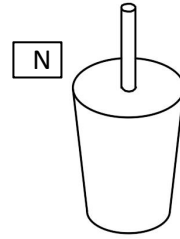

**Leg X 4PCS**

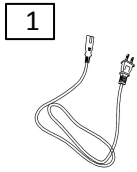

**Power cord X 1PC**

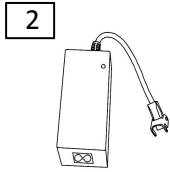

**Transformer X 1PC**

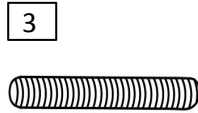

**Bolt X 1PC**

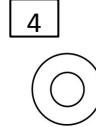

**Washer X 1PC**

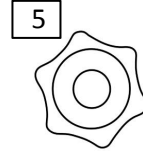

**Spring Washer X 1PC**

## PARTS LIST-BOX 2 SKU:WF306871

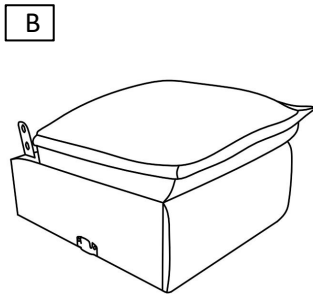

**Armless Chair Base X 1PC**

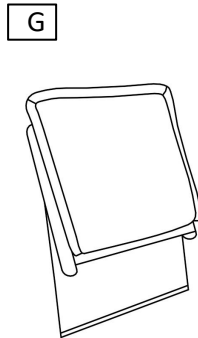

**Armless Chair Backrest X 1PC**



**Leg X 4PCS**

## PARTS LIST-BOX 3 SKU:WF306869

C

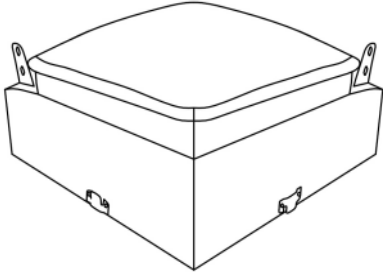

Wedge Base X 1PC

I

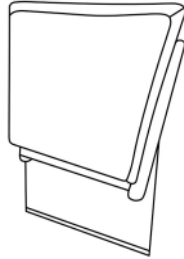

Wedge Rhf Backrest X 1PC

N



Leg X 4PCS

## PARTS LIST-BOX 4 SKU:WF306868

L

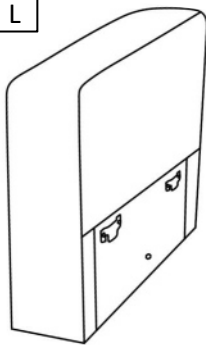

Lhf Armrest X 1PC

M

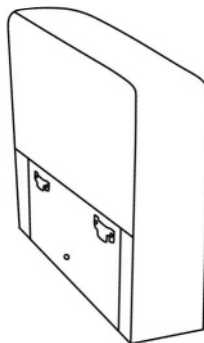

Rhf Armrest X 1PC

H

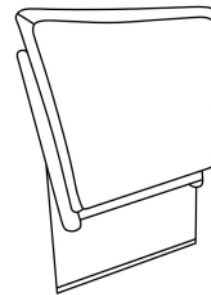

Wedge Lhf Backrest X 1PC

## PARTS LIST-BOX 5 SKU:WF306871

D

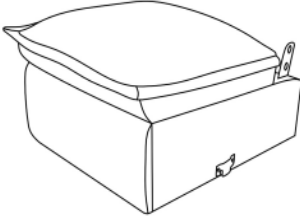

Armless Chair Base X 1PC

J



Armless Chair Backrest X 1PC

N



Leg X 4PCS

## PARTS LIST-BOX 6 SKU:WF306870

E

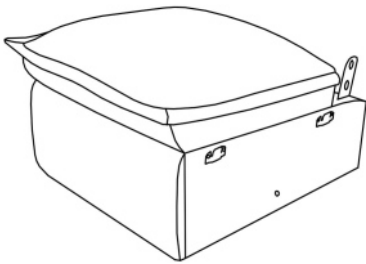

Rhf Recliner Base X 1PC

K



Rhf Recliner Backrest X 1PC

N



Leg X 4PCS

1



Power cord X 1PC

2



Transformer X 1PC

3

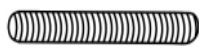

Bolt X 1PC

4



Washer X 1PC

5



Spring Washer X 1PC

**STEP 1: Manually screw N X 4 to A, N X 4 to B, N X 4 to C, N X 4 to D, N X 4 to E**

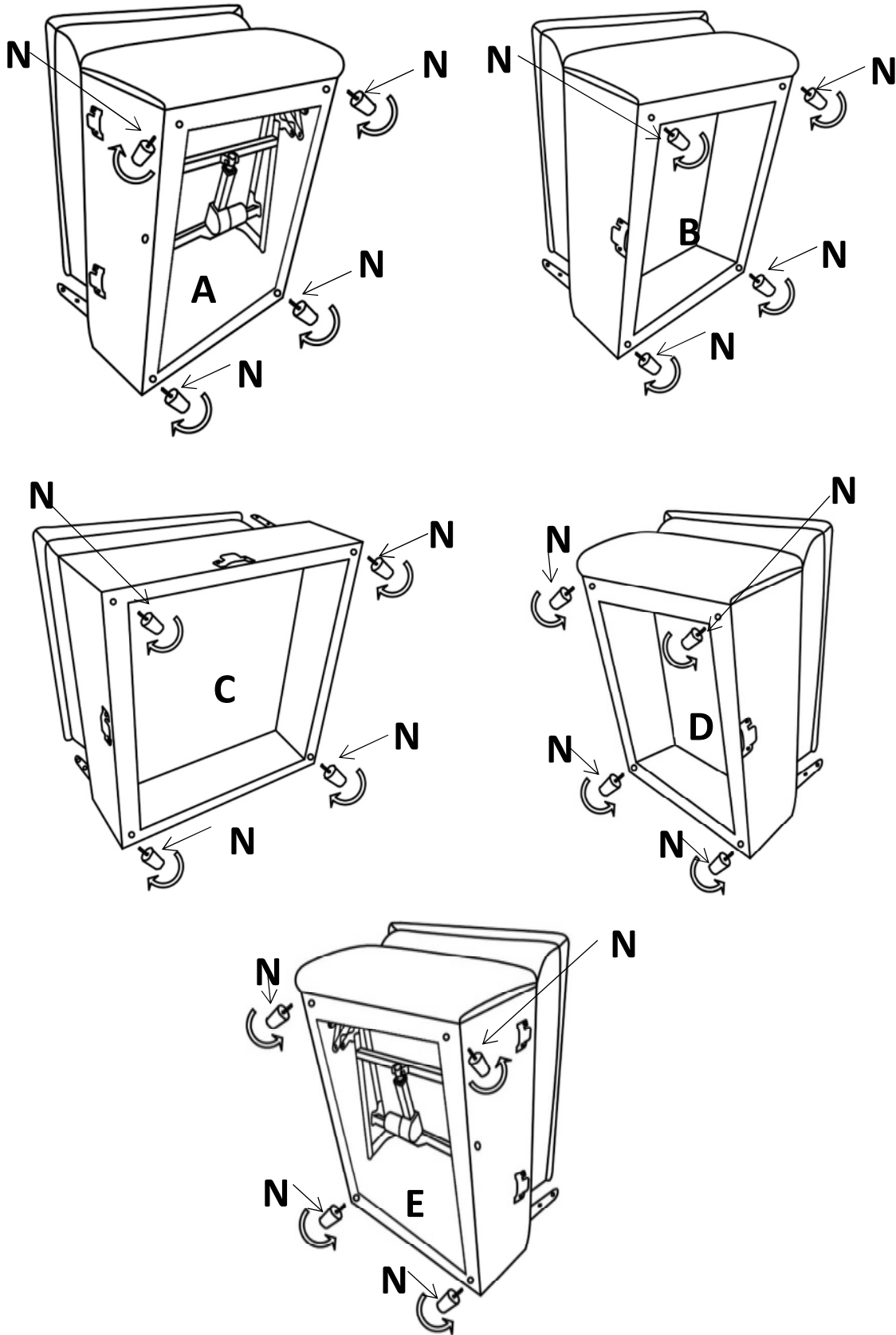

STEP 2: Insert L to A, M to E

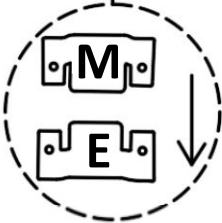
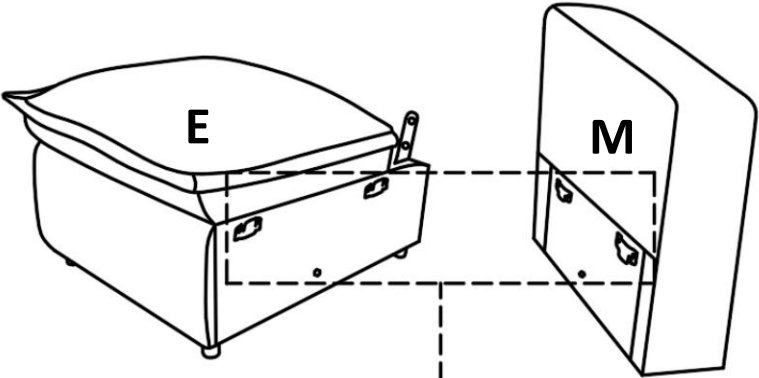
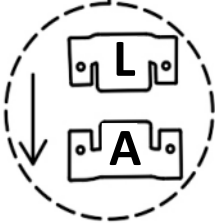
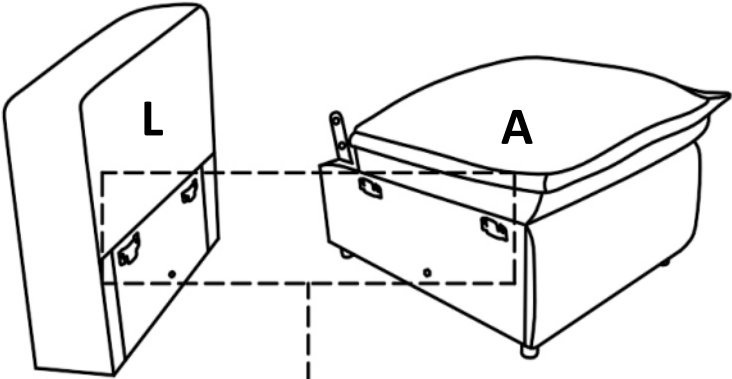

STEP 3: Attach to A&E with 3, 4, 5,

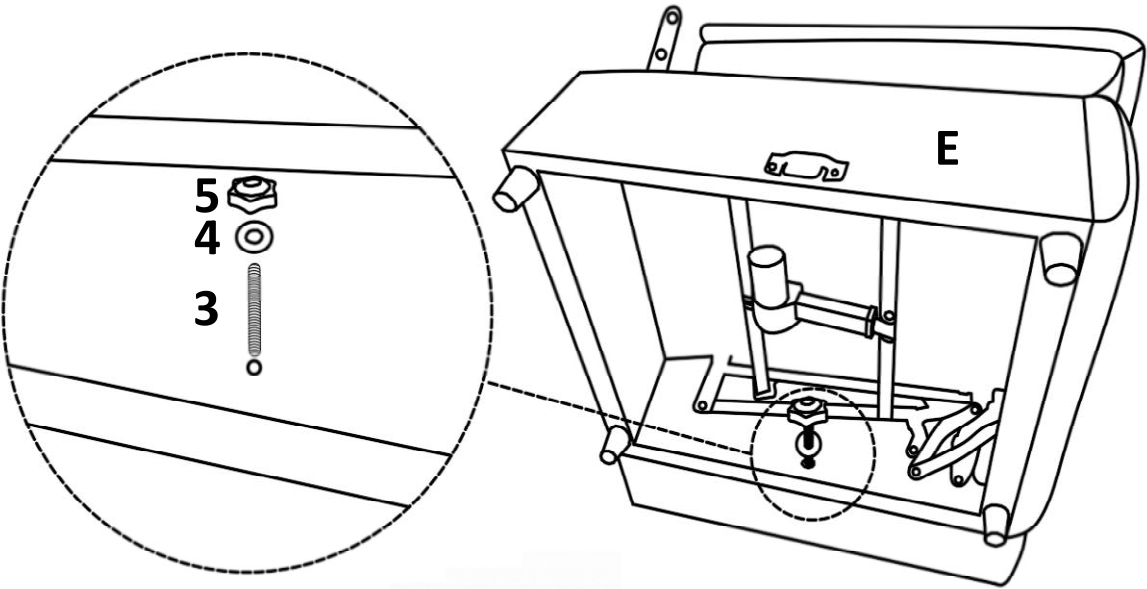
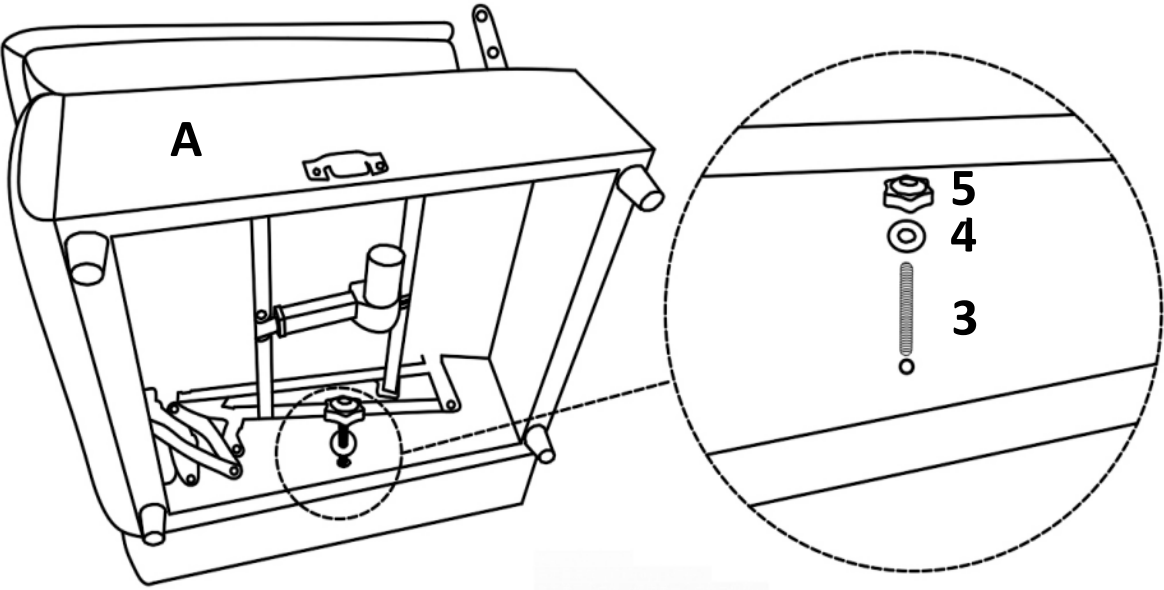

STEP 4: Attach to A&E as shown

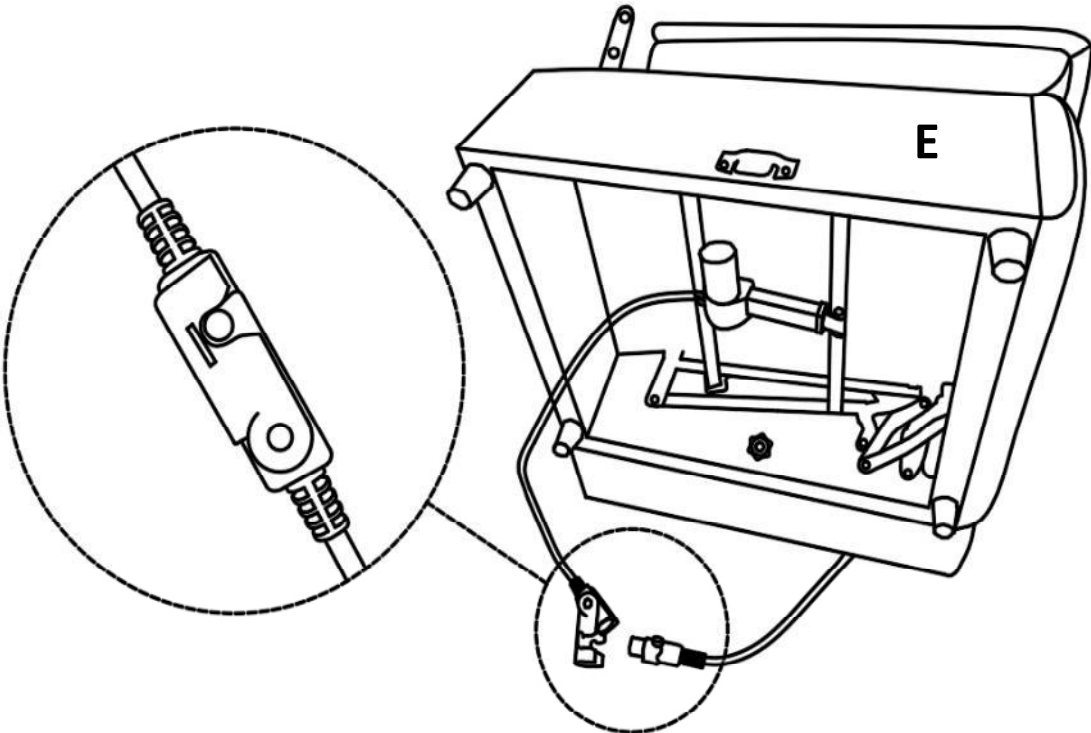
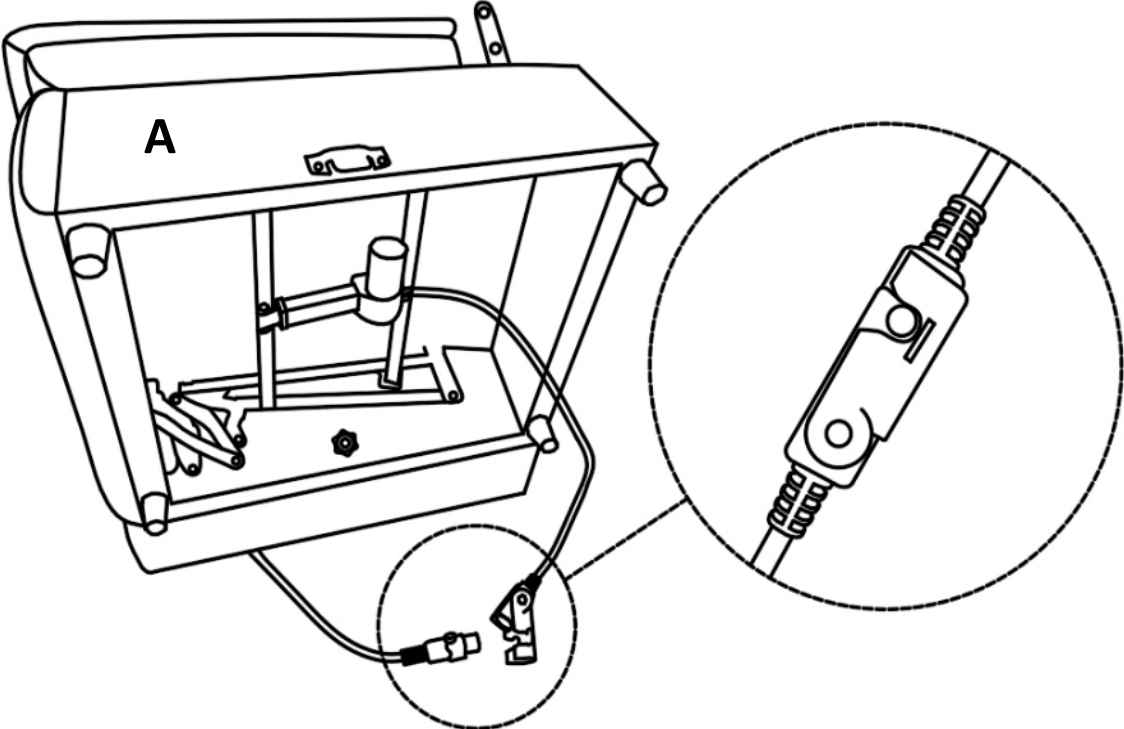

STEP 5: Insert F to A, G to B, H&I to C, J to D, K to E

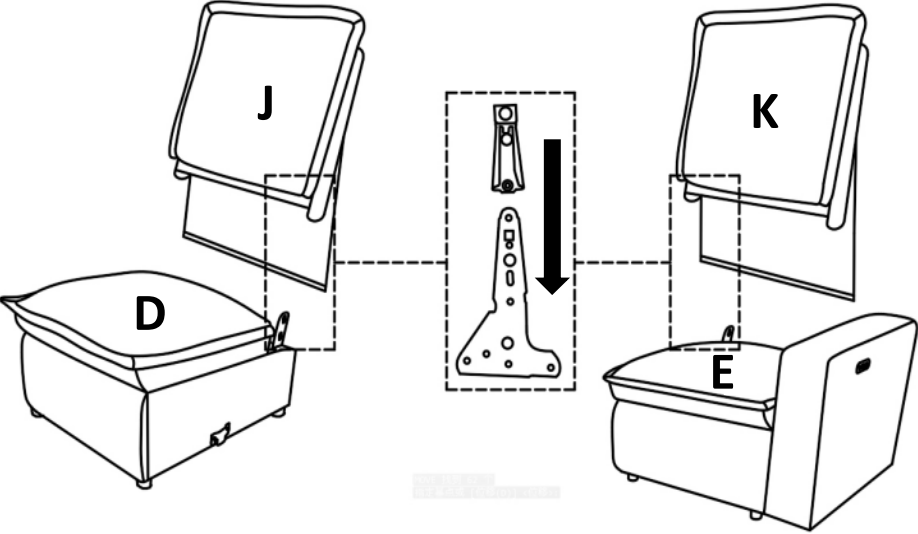
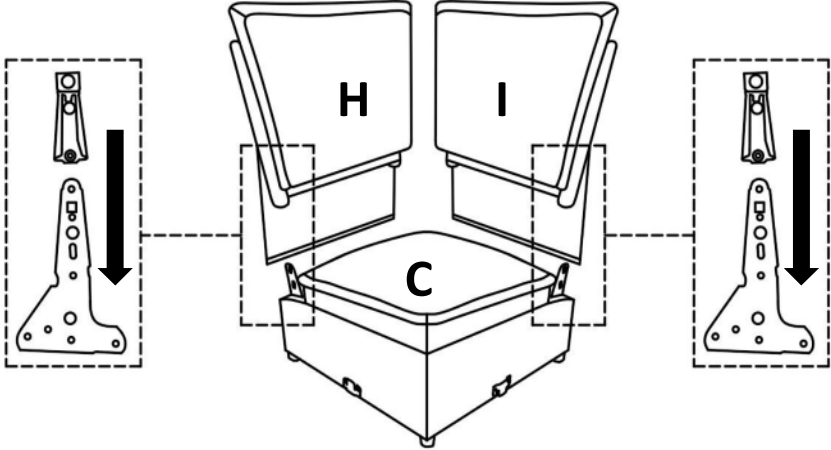
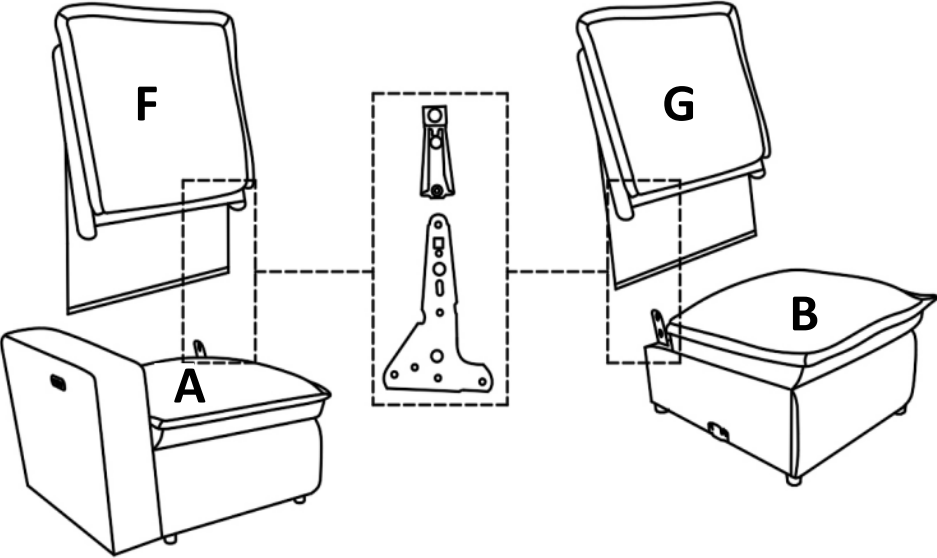

**STEP 6: Insert A to B, B to C, C to D, D to E**

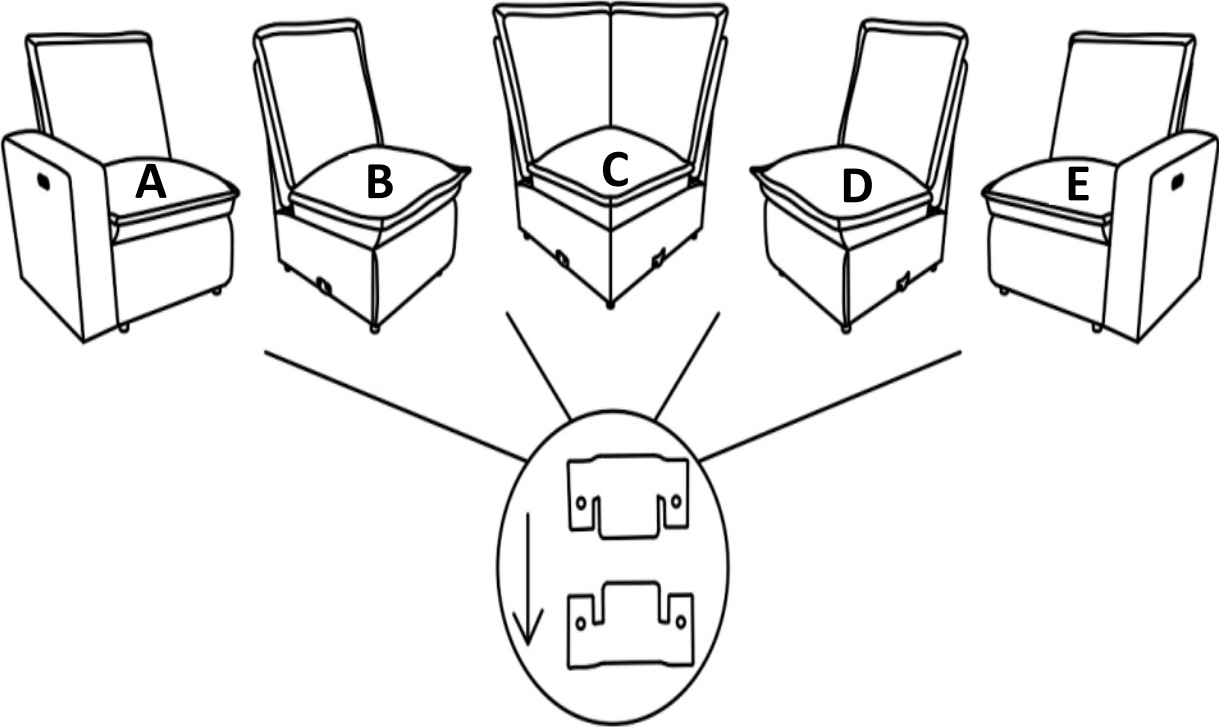

**STEP 7: Attach to A&E with 1,2**

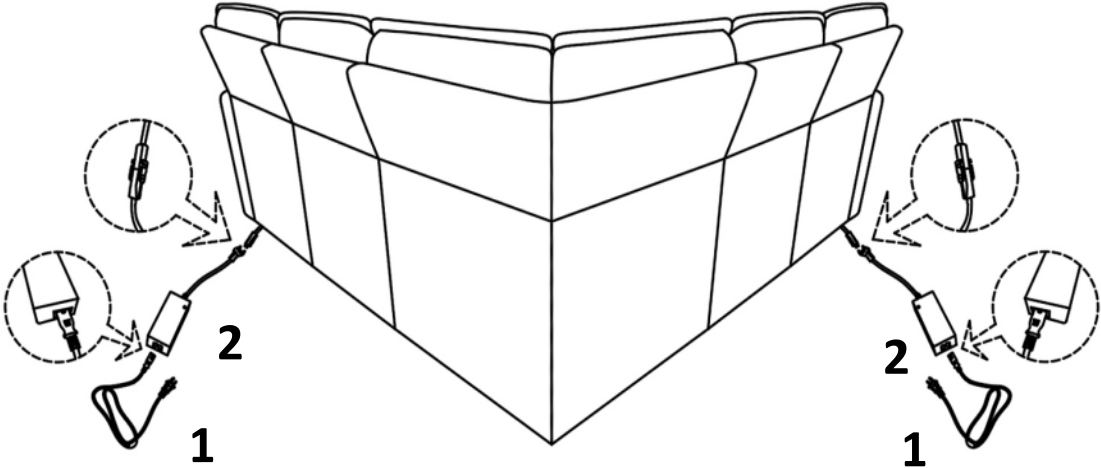

**STEP 8: Ready to use**

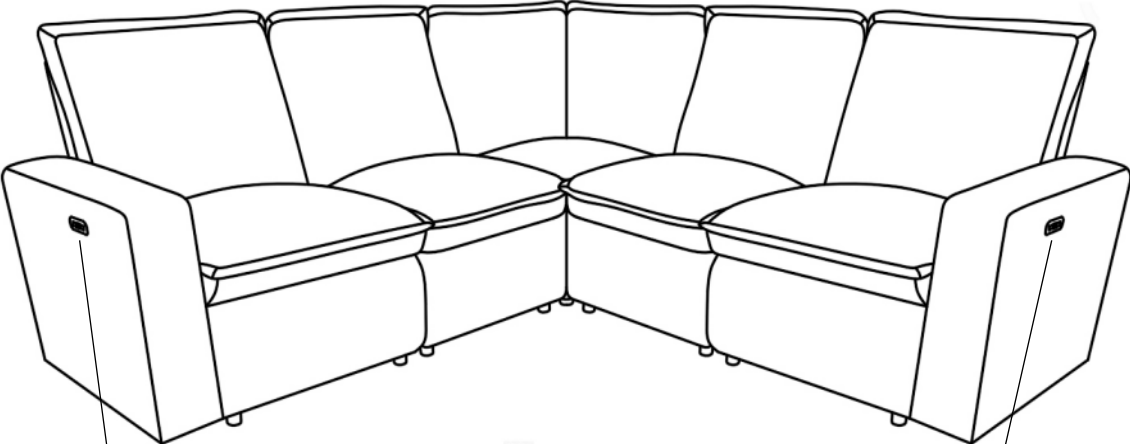

**USB**

